

LODGES

CAO LOIC

Master Thesis SS21

VOLUPTAS Chair Charbonnet / Heiz ETHZ

Logistics (n.)

Art of moving, quartering, and supplying troops, 1846, from French (l'art) logistique “(art) of quartering troops,” which is from logis “lodging” (from Old French logeiz “shelter for an army, encampment”

Oxford Dictionary



9:31

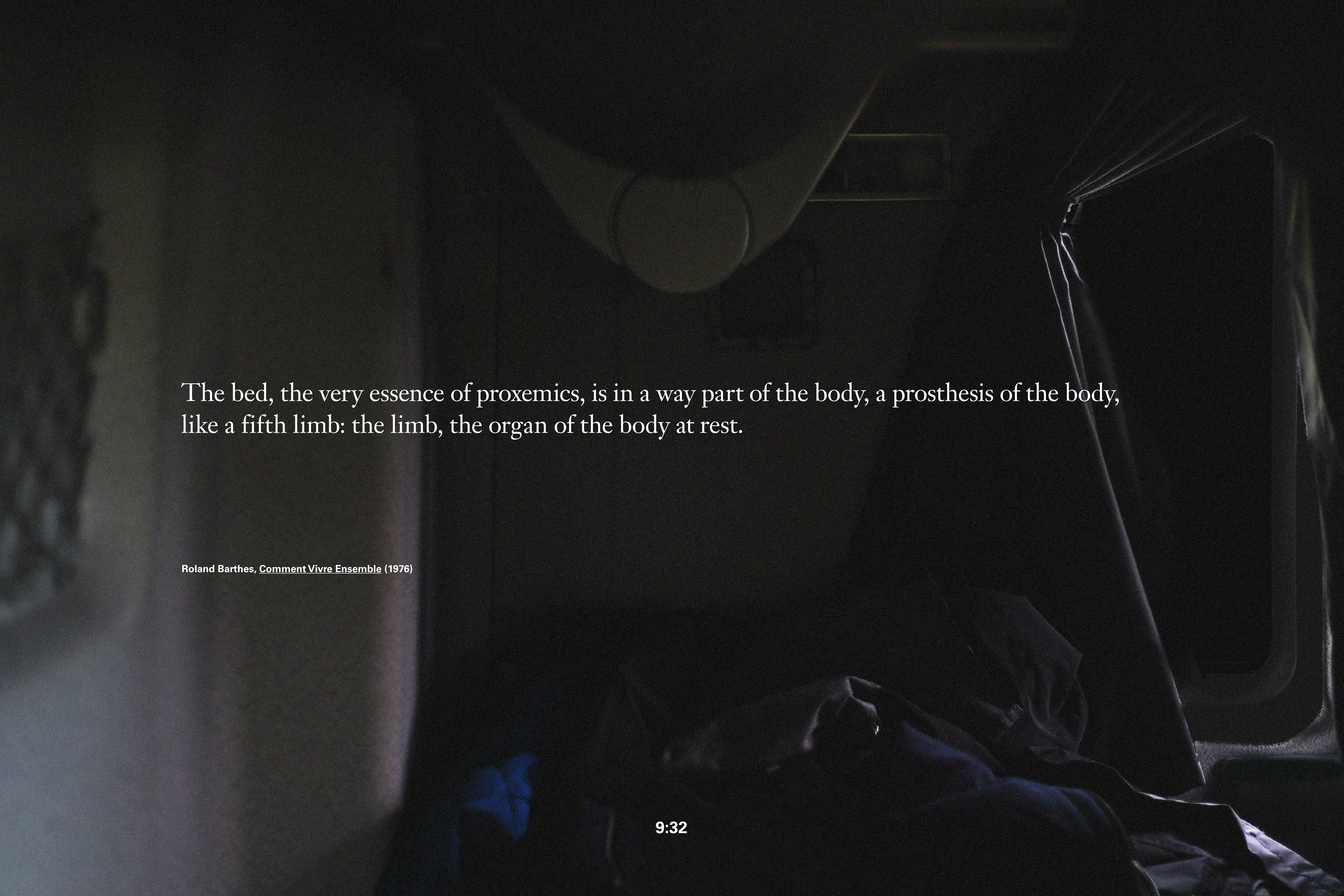

The bed, the very essence of proxemics, is in a way part of the body, a prosthesis of the body, like a fifth limb: the limb, the organ of the body at rest.

Roland Barthes, *Comment Vivre Ensemble* (1976)

9:35

SWC_002
RADIO 24 - DAS ISCH ZÜRICH
SWR3

FMI+





9:38



9:50



9:54



9:55

oil : ca. 2000km autonomy
e-truck : ca. 300km autonomy

time controller

couchettes

cabin : ca. 5m²

Optional personal storing space.

W. max= 40t

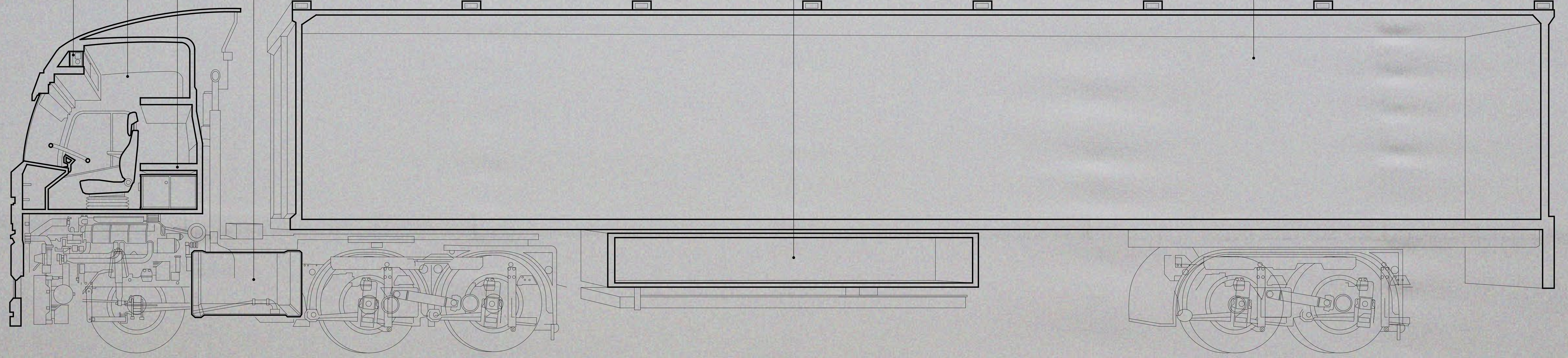

Lmax= 18.45m



10:01



11:16

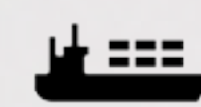

59%

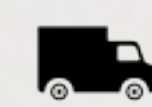

31%



10%



0.2%



11:30

“These places are not meaningful in themselves but only as nodes of these networks.”

Manuel Castells, *Unknown* (unknown)

11:39



11:48



www.schaffli.ch
Schaffli
Sachstrassen
Immer gut in Betrieb
CH
49717

NETRIUM
ICT solutions
SKODA
AG-553185

BAR
AG-708994

11:56



0,30 4h20

⏪ ▲ ▼ ⏩ OK

2

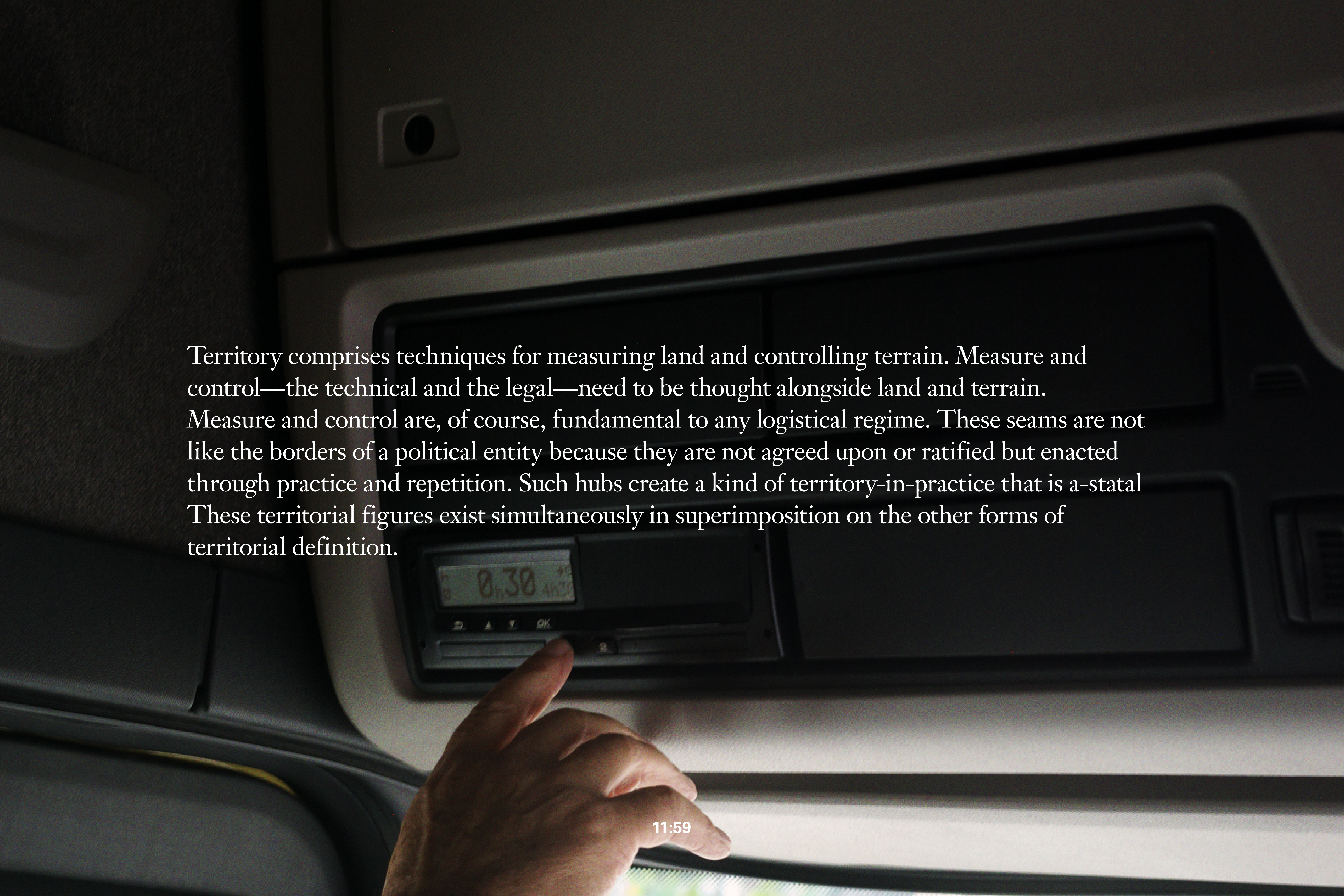

11:58

A close-up photograph of a person's hand pointing at a car's infotainment screen. The screen displays '0:30' in a digital font. The background is the interior of a car, showing the dashboard and door panel. The text is overlaid on the left side of the image.

Territory comprises techniques for measuring land and controlling terrain. Measure and control—the technical and the legal—need to be thought alongside land and terrain. Measure and control are, of course, fundamental to any logistical regime. These seams are not like the borders of a political entity because they are not agreed upon or ratified but enacted through practice and repetition. Such hubs create a kind of territory-in-practice that is a-statal. These territorial figures exist simultaneously in superimposition on the other forms of territorial definition.



12:04



12:25



12:47



13:20

LKW-Anmelde

Corona Maßnahme
Ab sofort gilt:
- Bitte Besuchsnummer zeigen
- Masken tragen für LKW-Mitarbeiter
- Mehr gute Gesundheit -
- bitte!

Informational notices and forms posted on the window.

Administrative forms and notices on a counter.

14:20



14:23



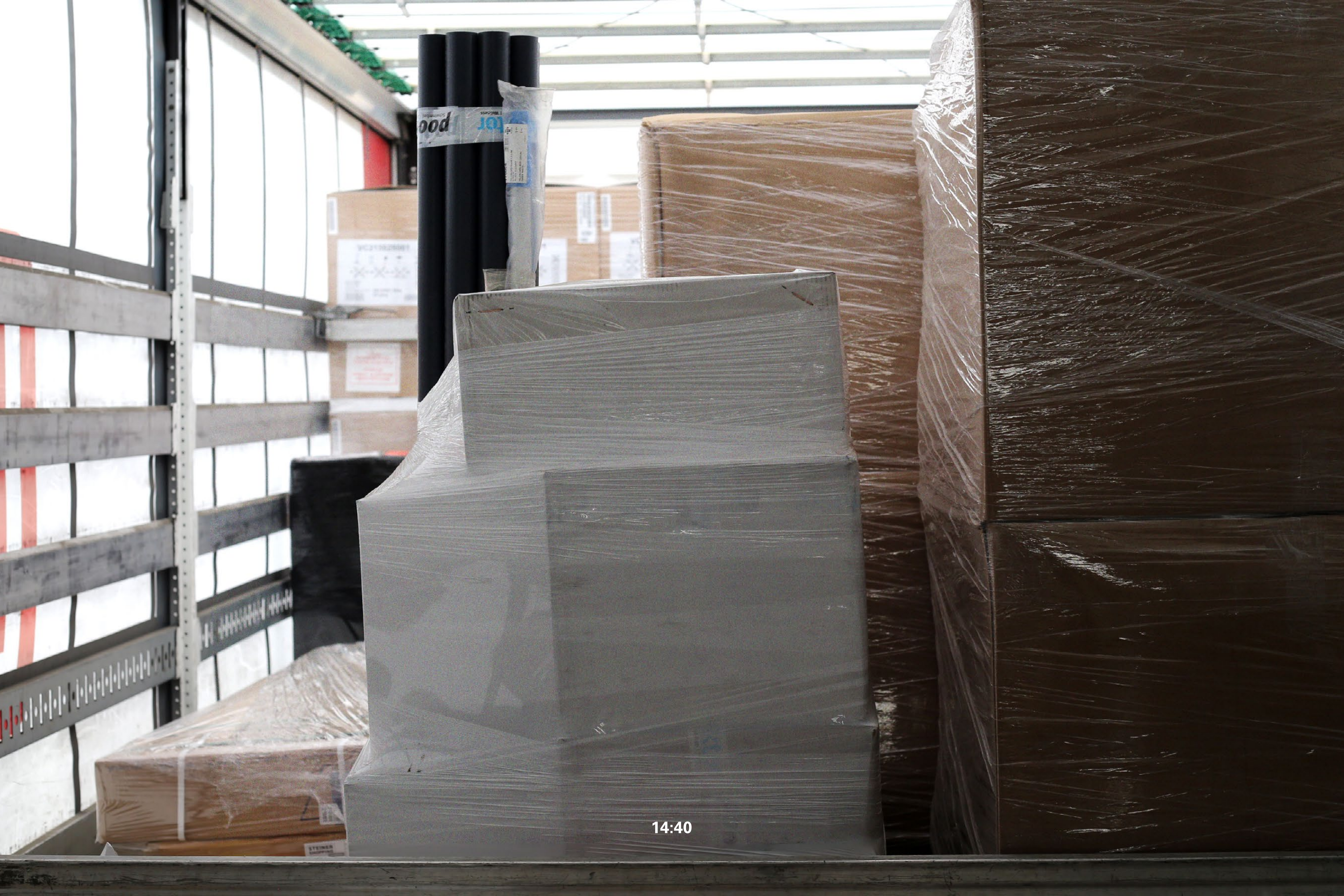

for
poo

VC21020881
VC21020881

14:40



14:50



15:27



15:59



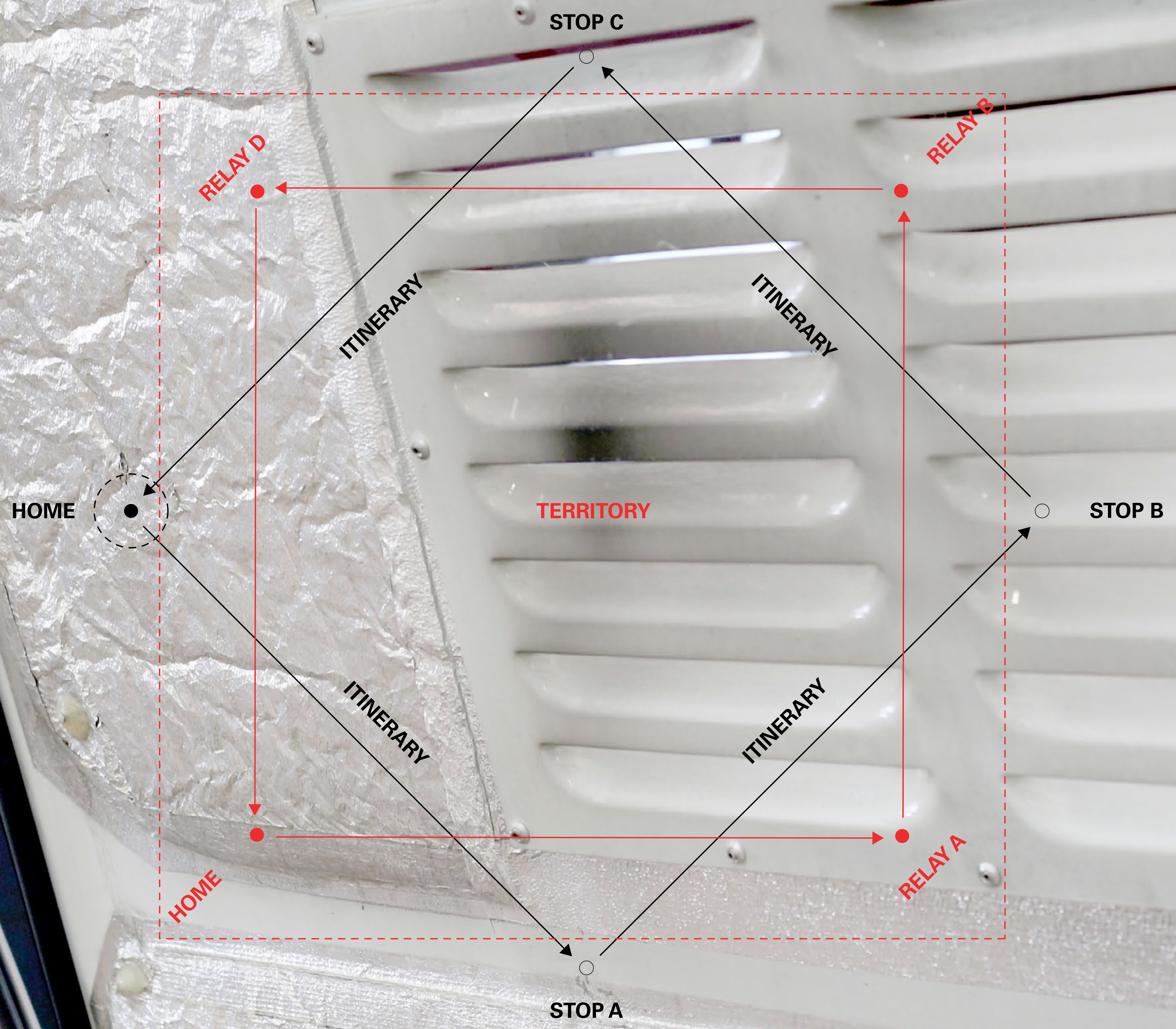



18:50



18:50



21:30

FT

LOGISTICS

21:33



21:34

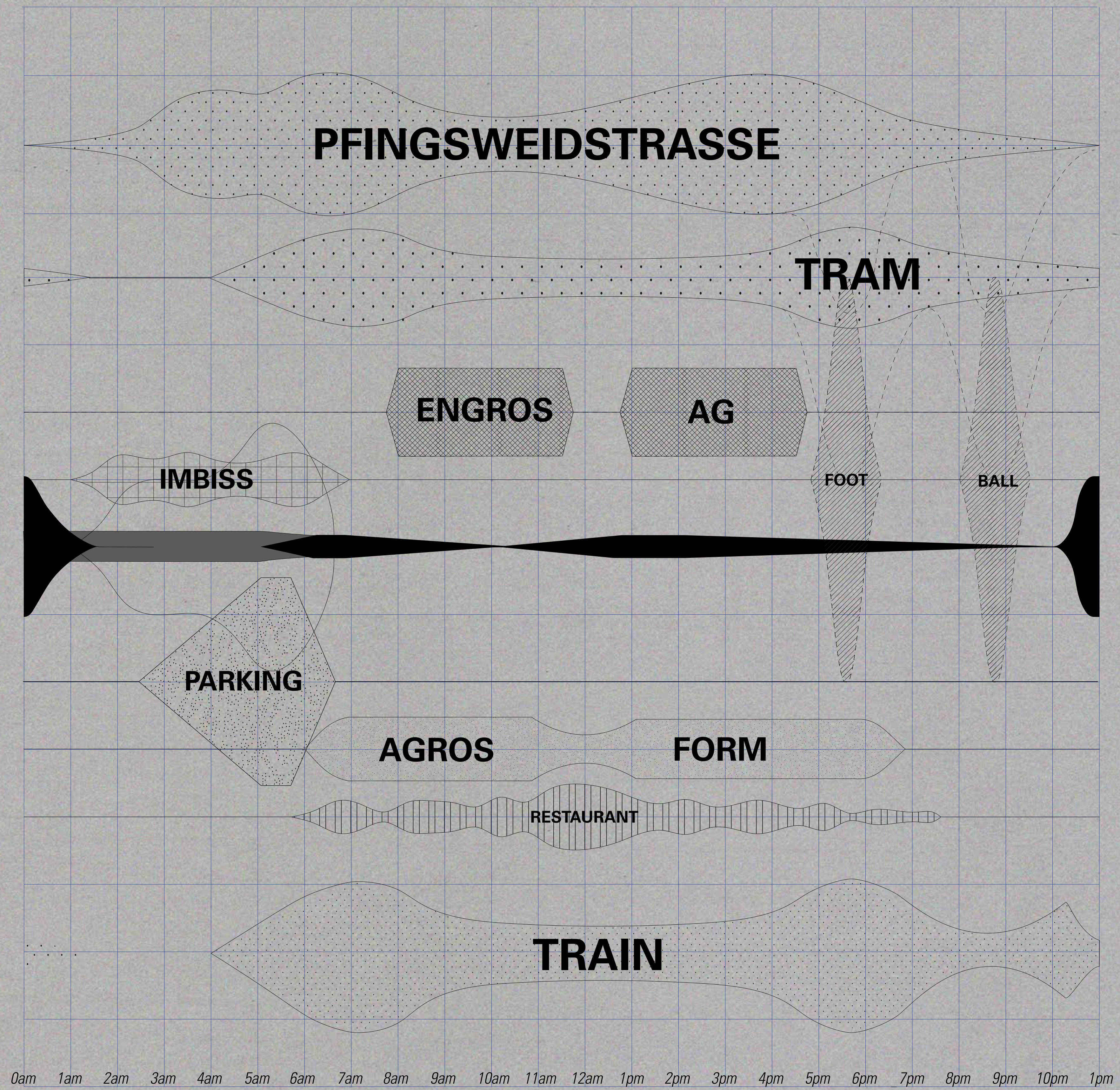

21:38



22:00

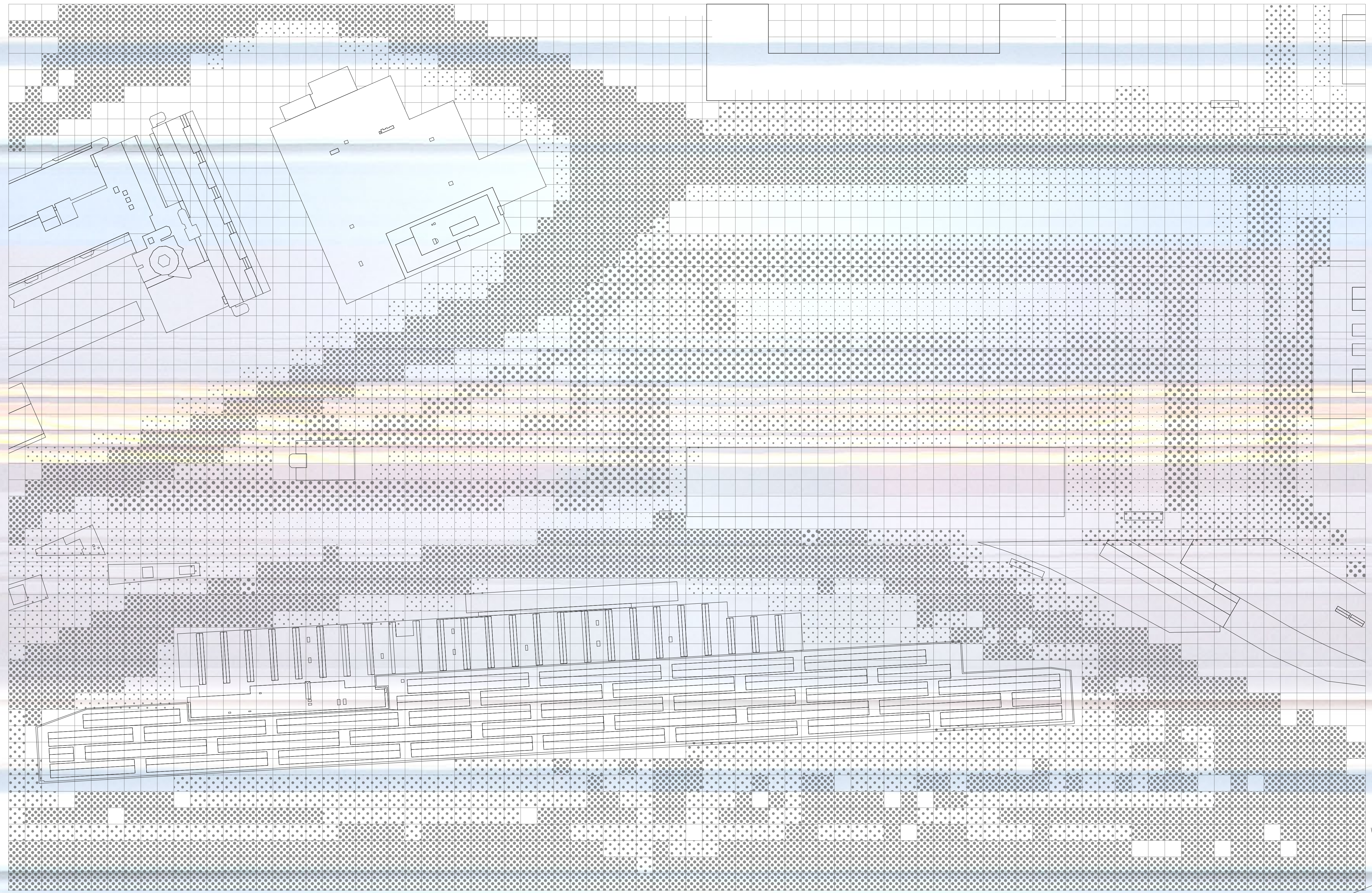



22:13

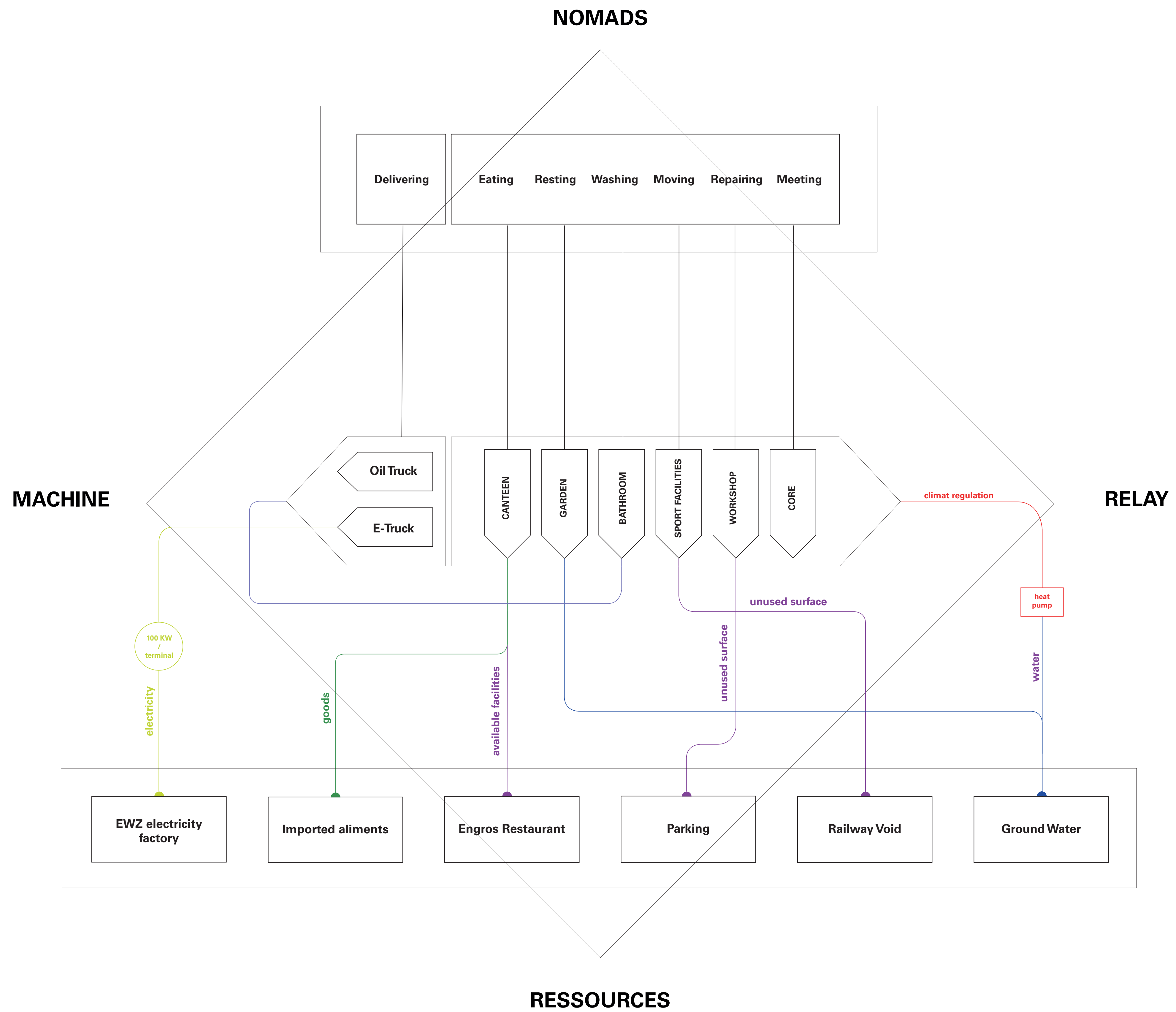

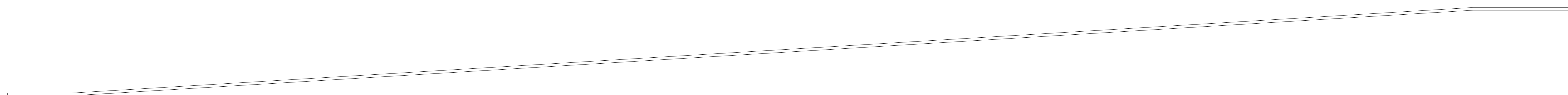

FOUNDATIONS

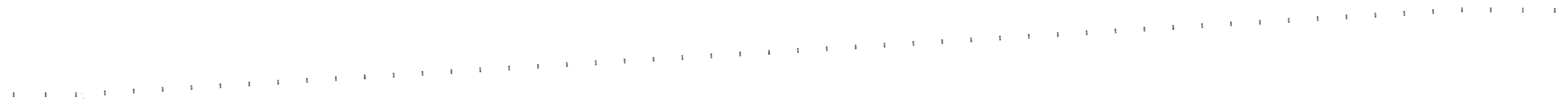

LEVEL 0

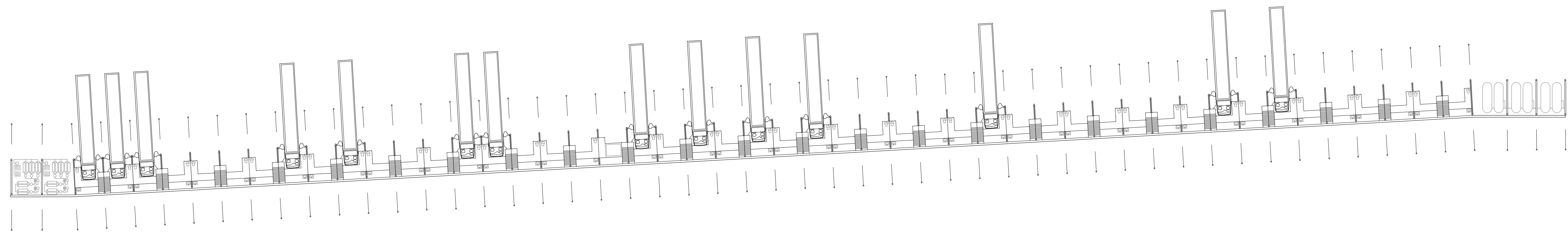

LEVEL 1

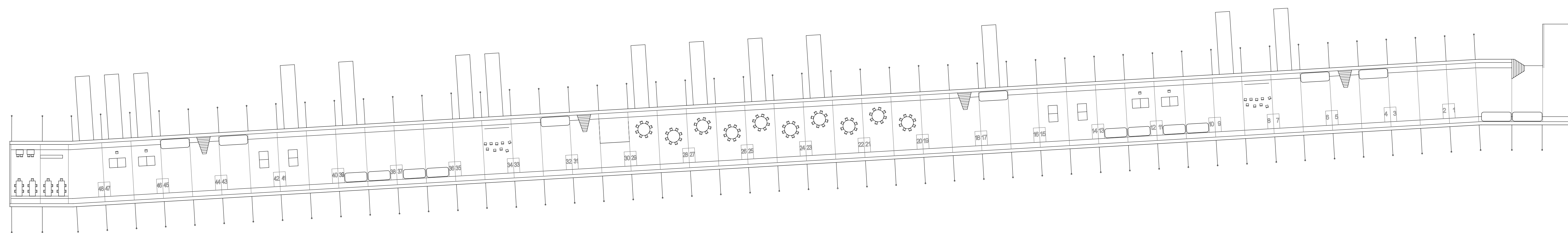

LEVEL 2

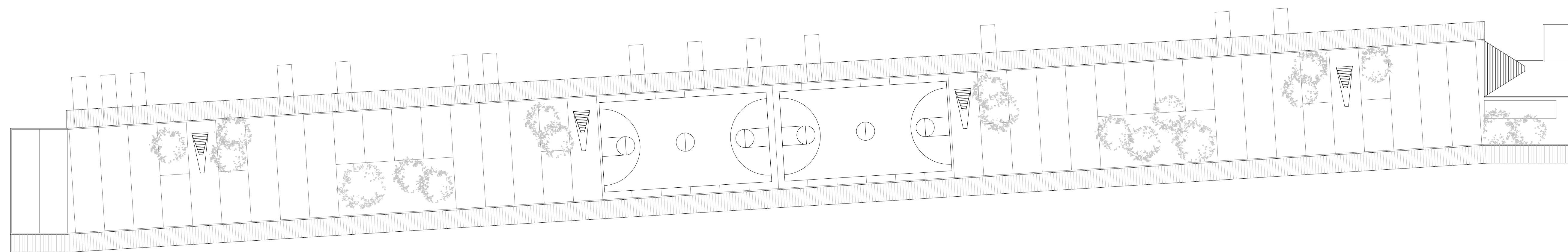

LEVEL 3



ORTHOPHOTO

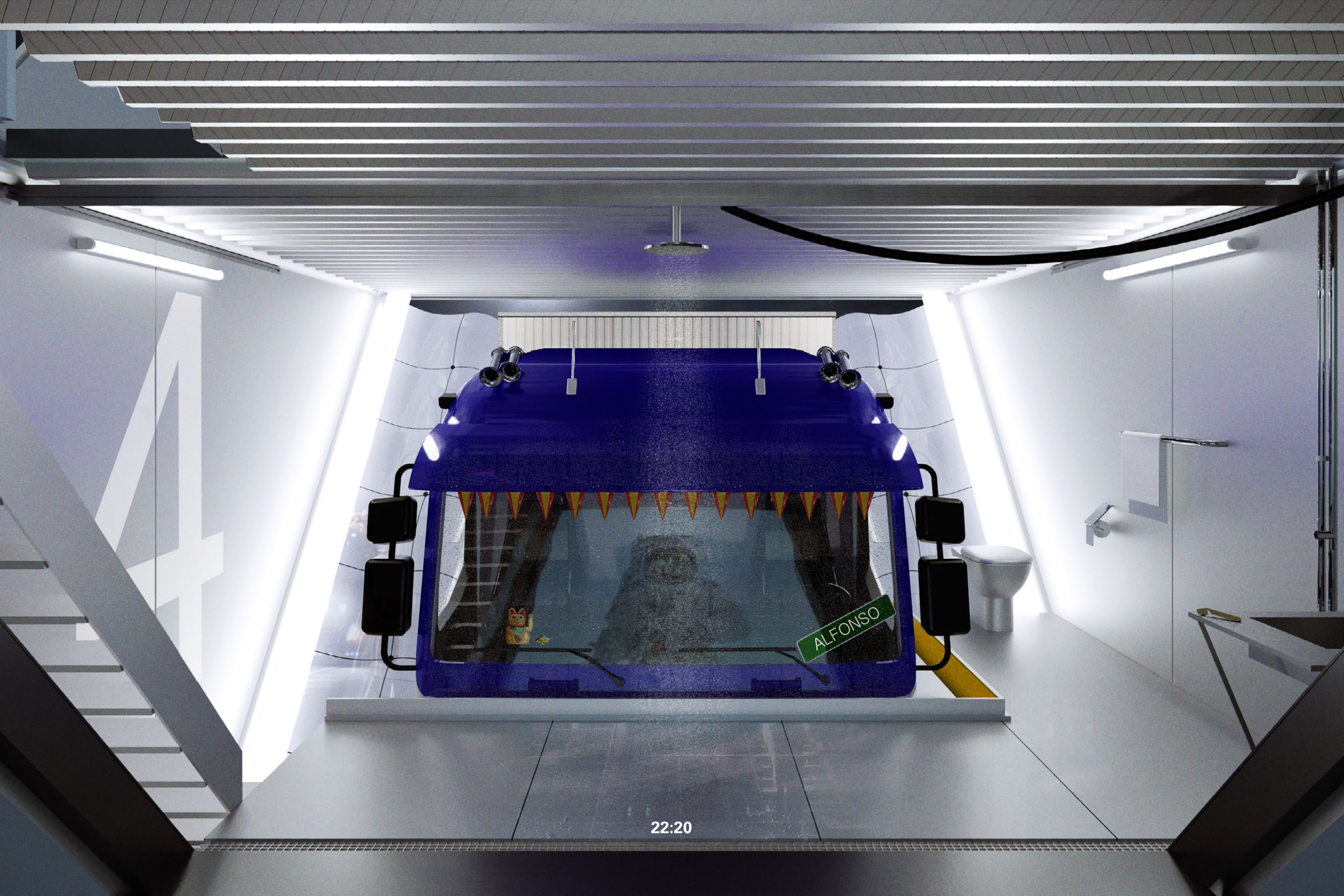

ALFONSO

22:20

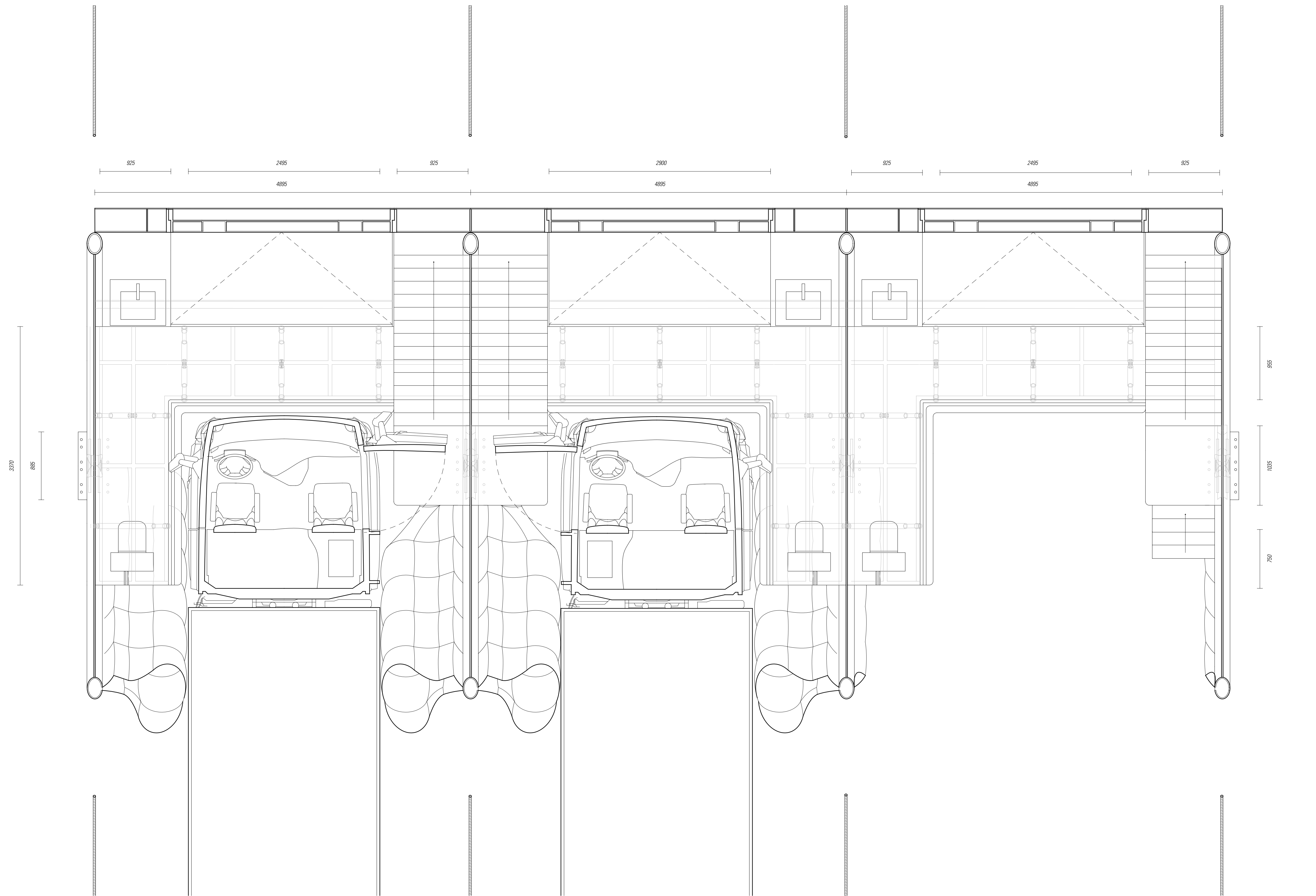

LEVEL 1

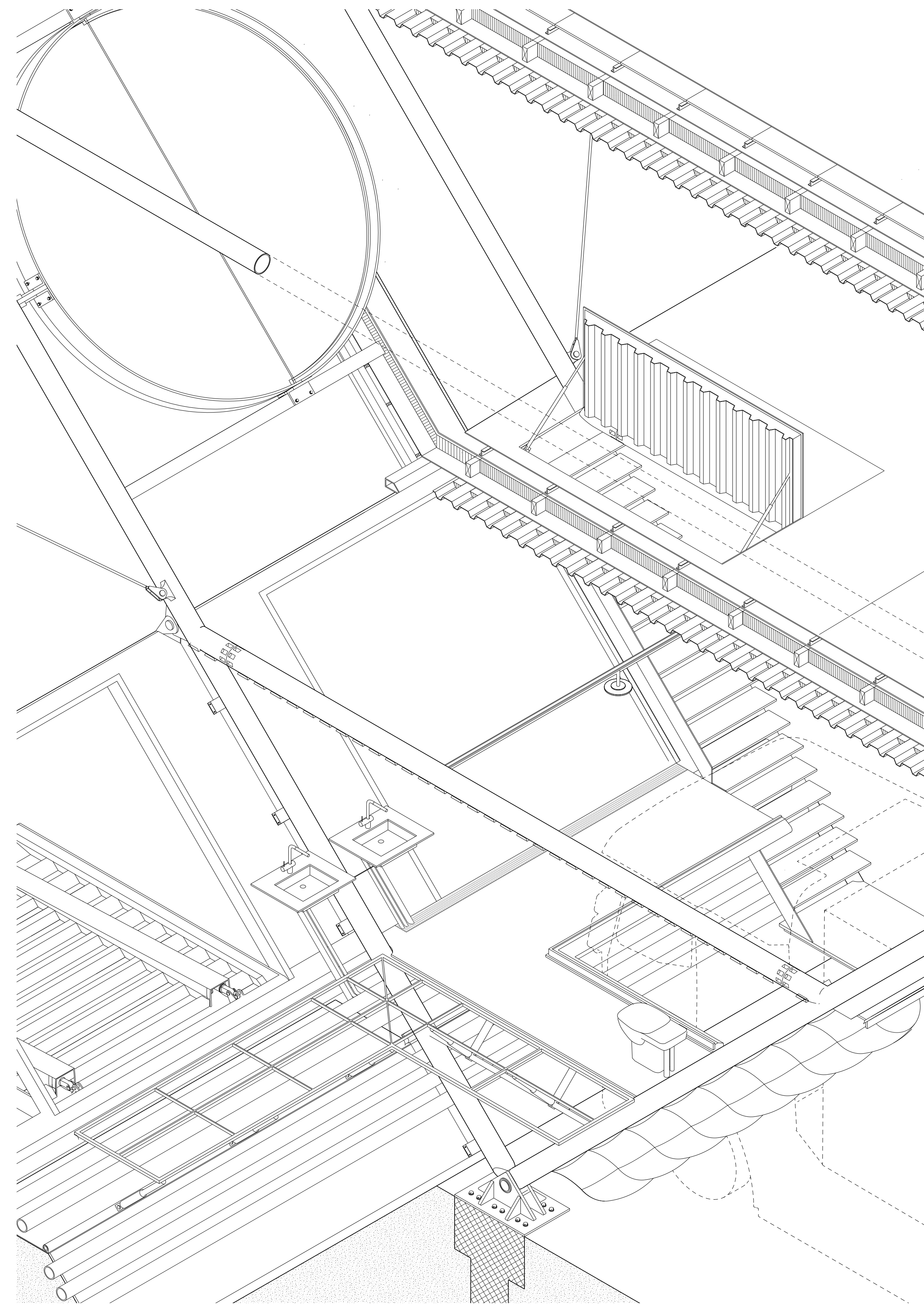

CONSTRUCTION

BESPOKE

MOD2

MOD2

MOD1

MOD1 + accordion

MOD2

MOD3

MOD3

MOD2

MOD2

BESPOKE

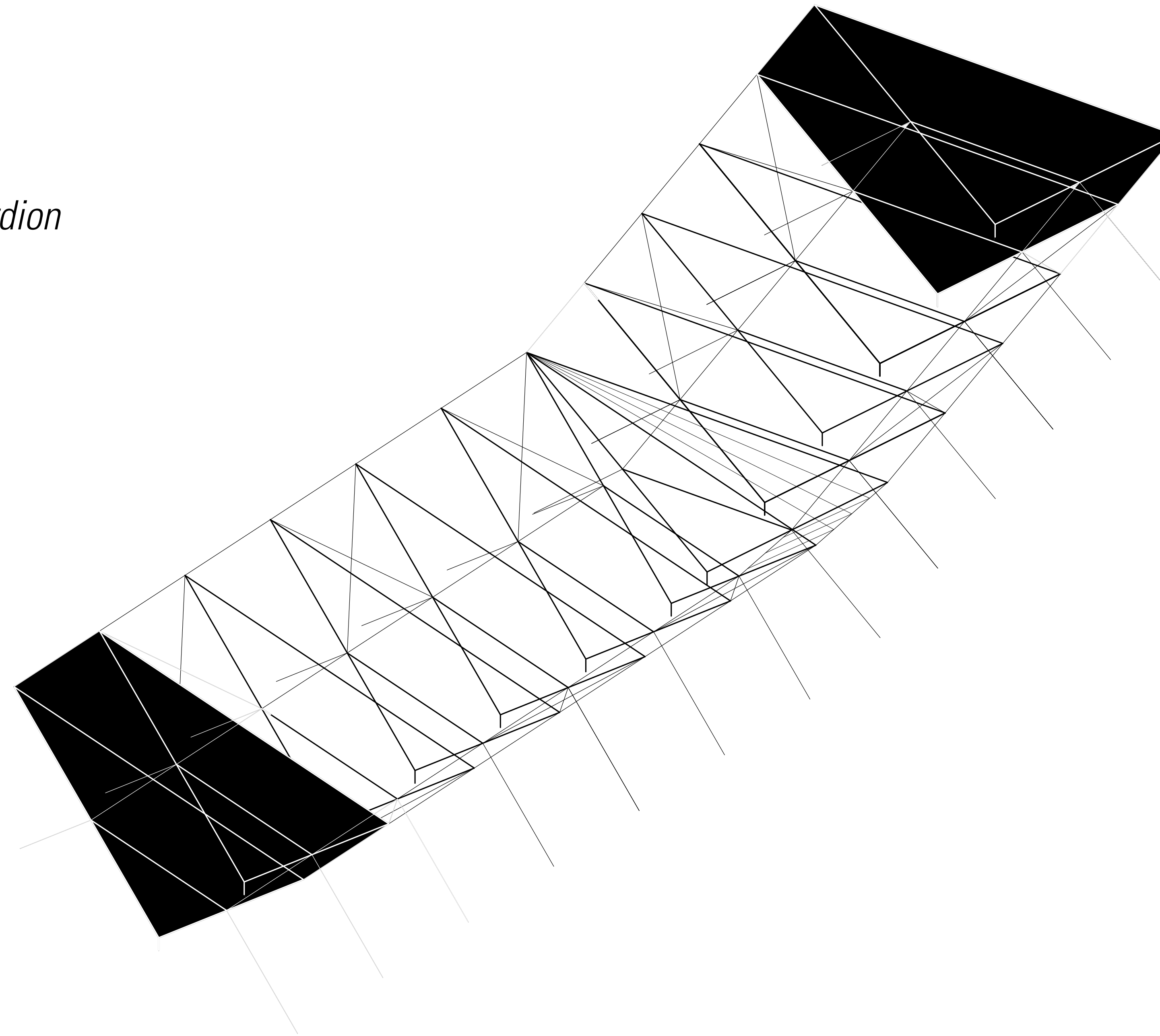

MODULARITY



INOX 01
N V L 92



7:00

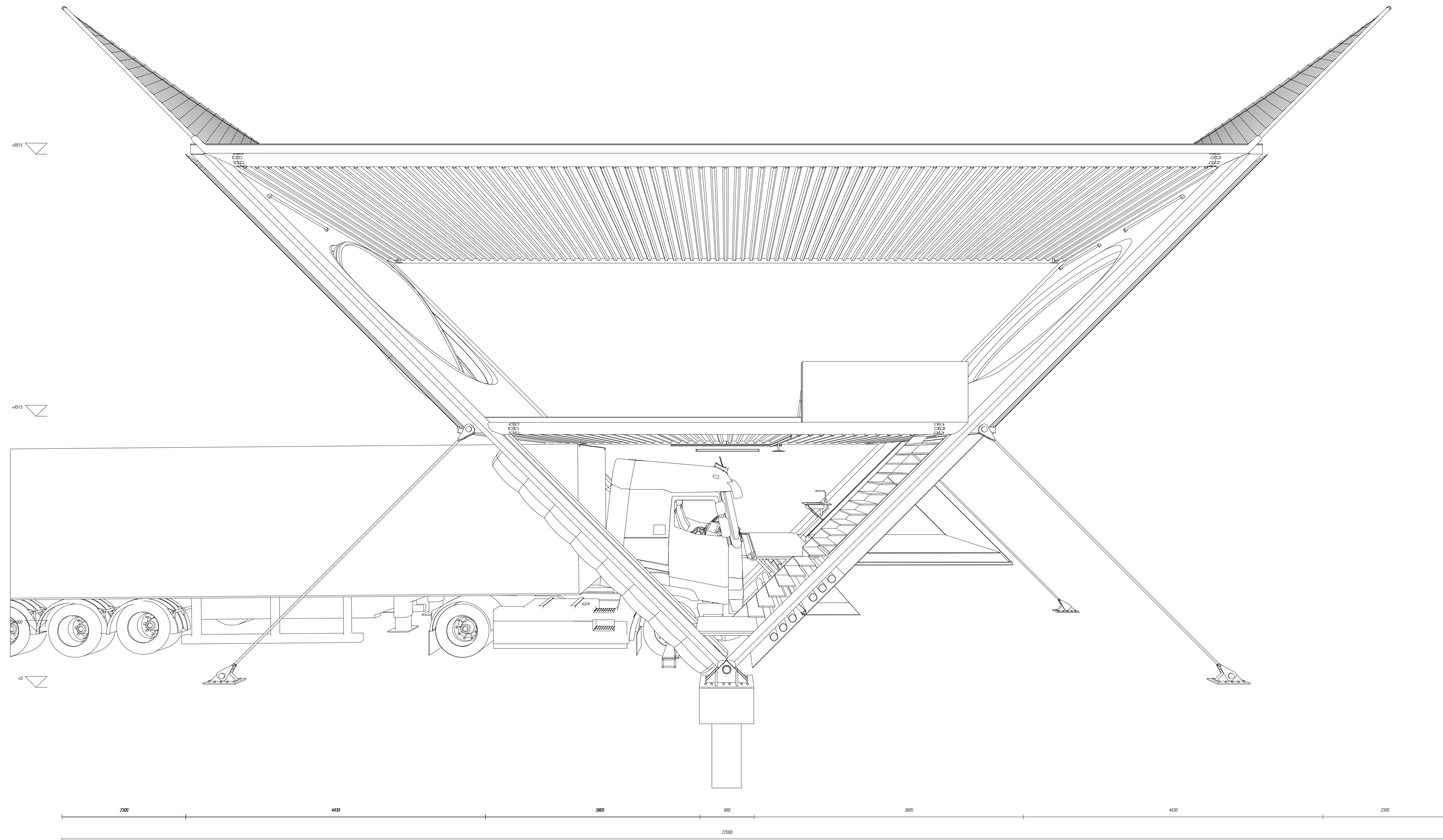

MOD 01

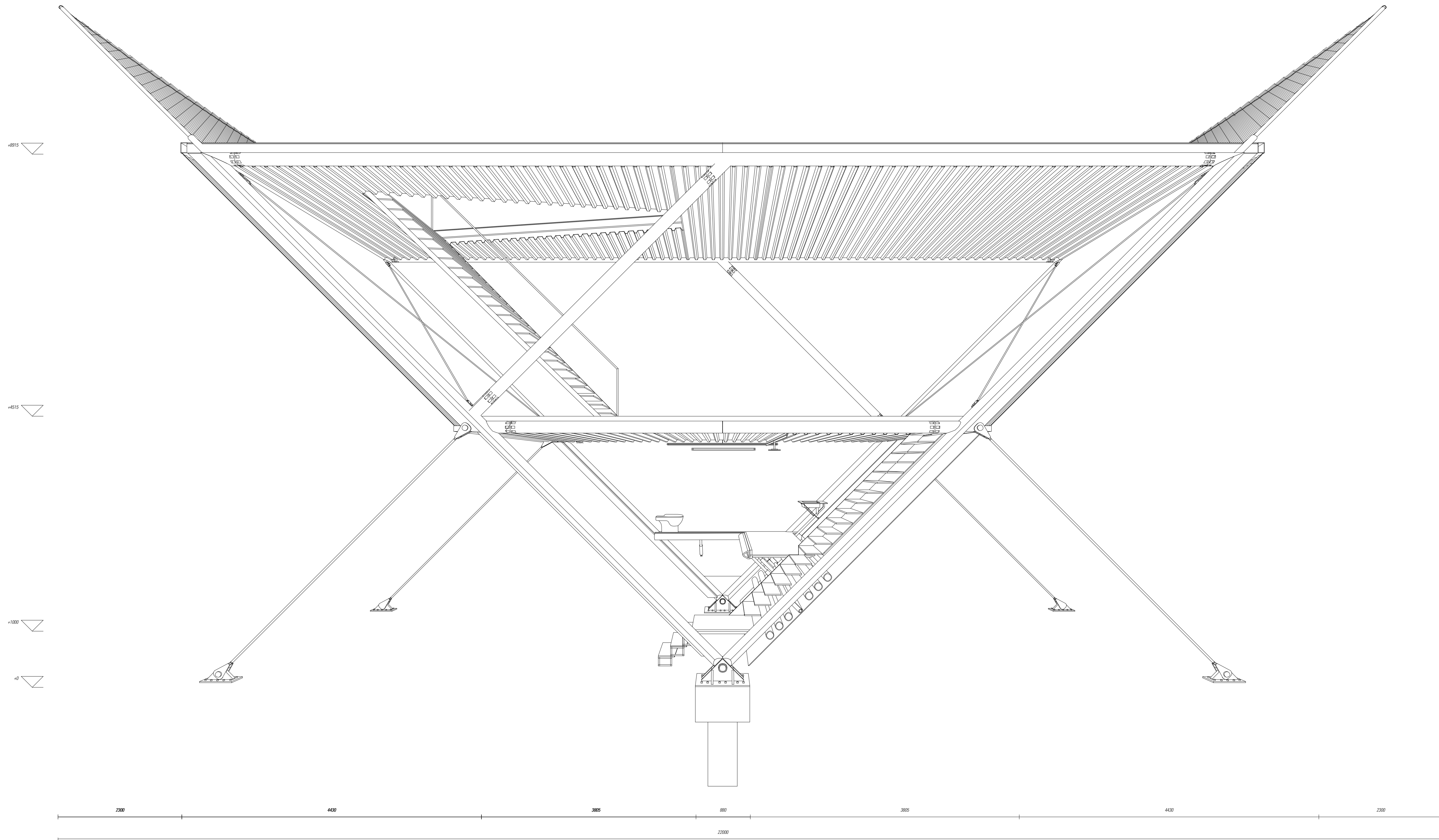

MOD 03

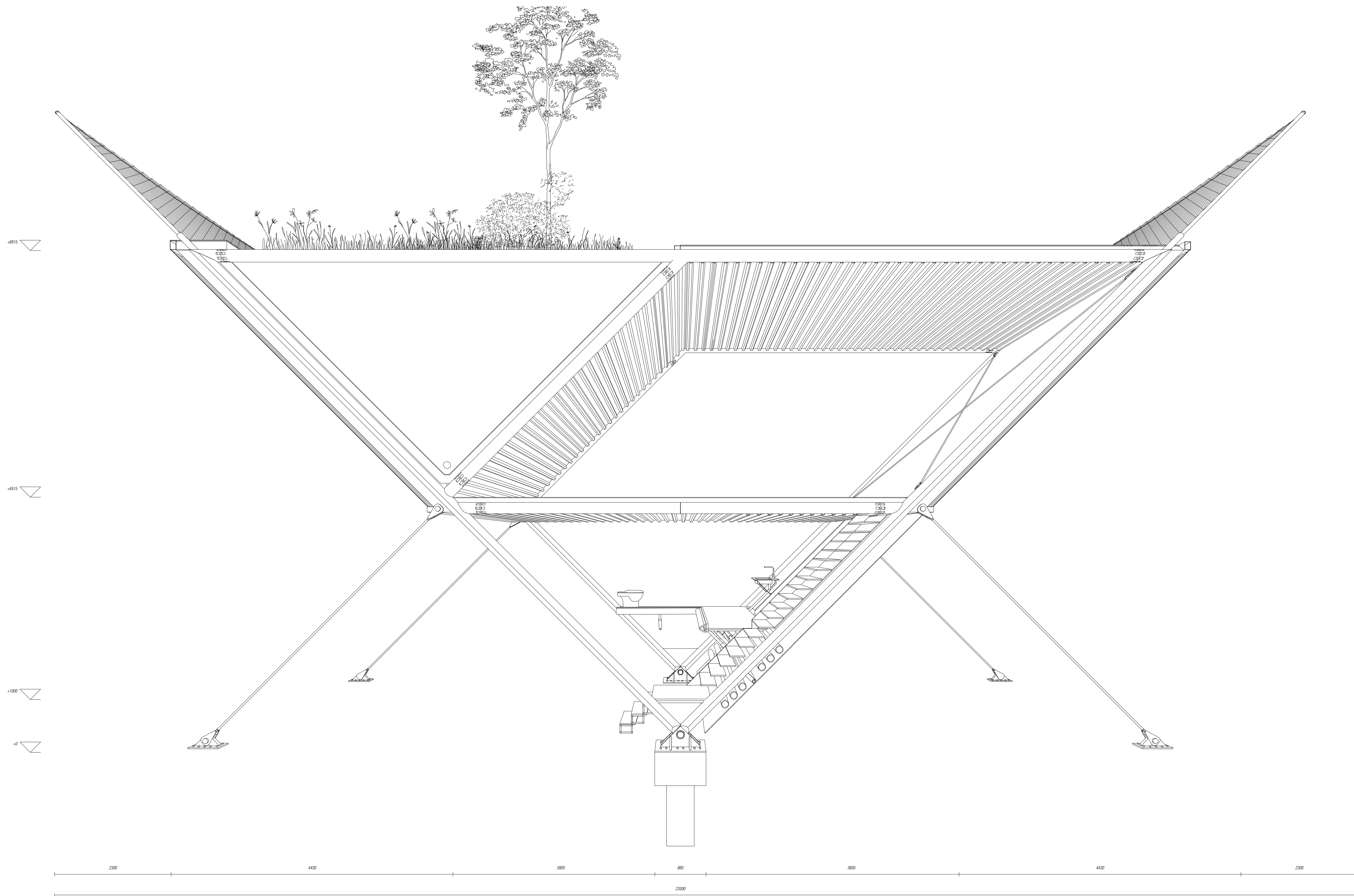

MOD 02

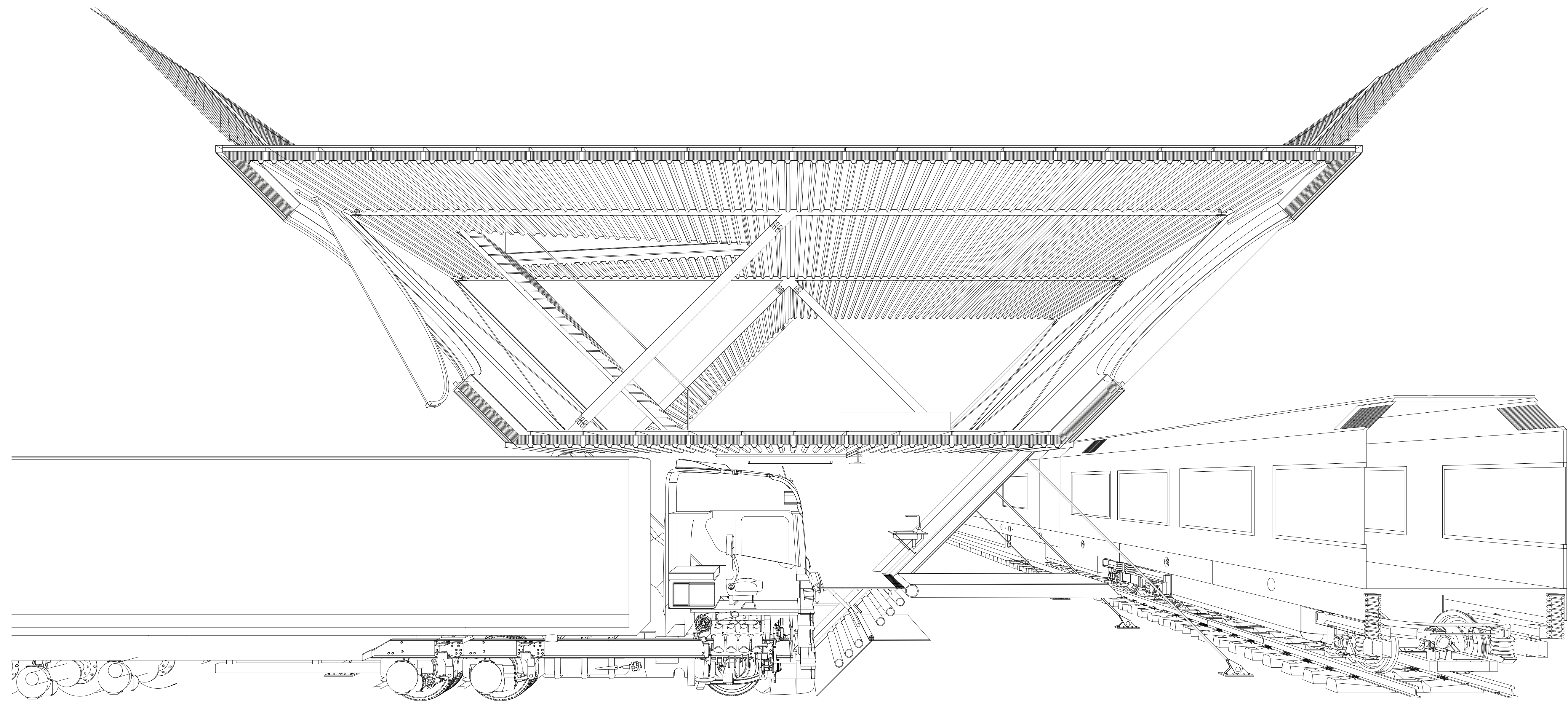

POSSIBLE COMBINATION

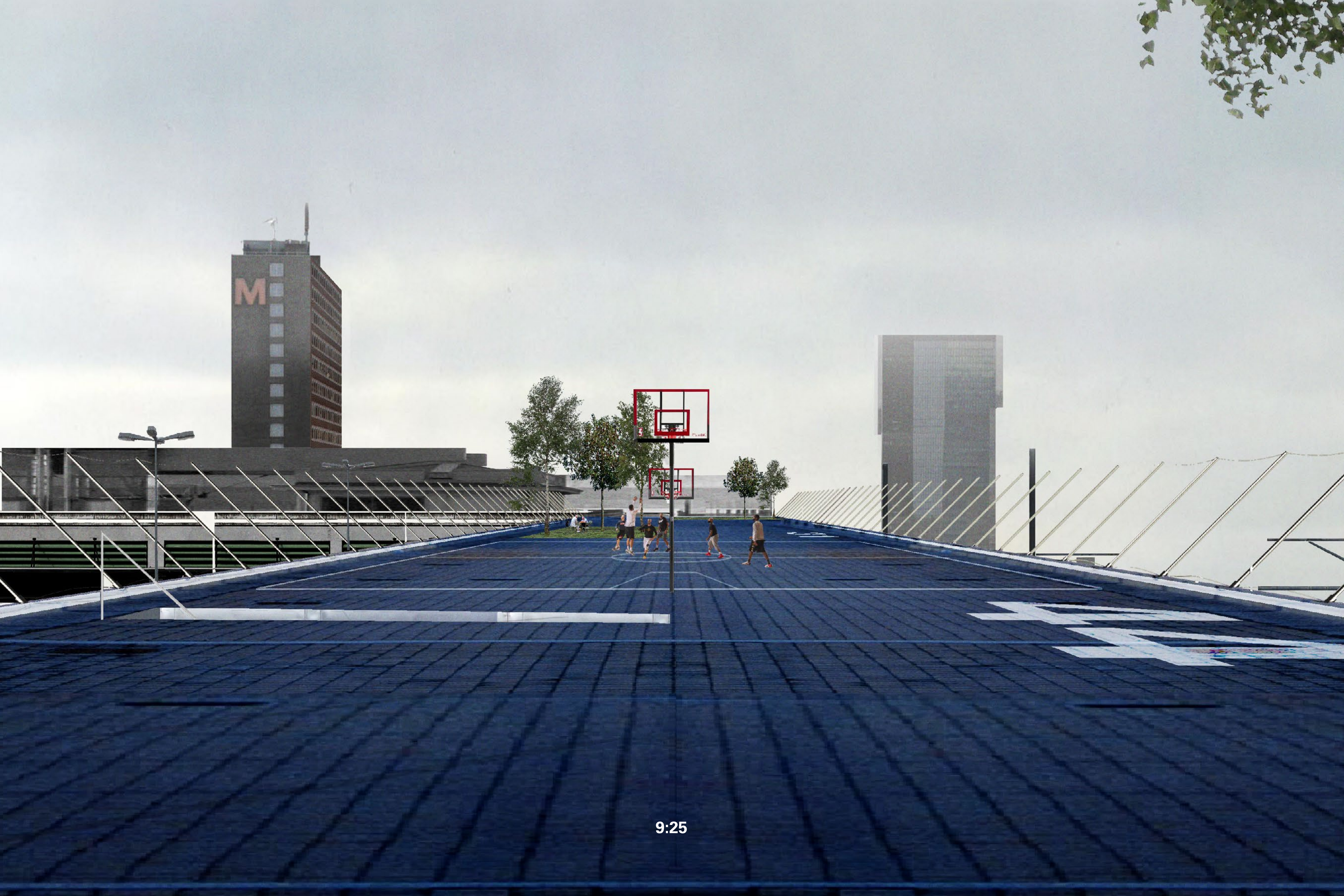

9:25

The project focuses on the essence of logistics, namely the maintenance of the workforces and their welfare.

The proposal questions profit-oriented planning characterized by the mix of programmes and different users, as well as tackles the conditions of an actor remaining at the end of the consumption's chain, the truck driver

Whereas the machine-centered vision of current logistic concentrates on optimisation of time and capital at the expense of the workers, the project replace the human at the center of the logistic apparatus.

Il me semble que je serais toujours bien là où je ne suis pas, et cette question de déménagement en est une que je discute sans cesse avec mon âme.

Charles Baudelaire, Any where out of the world (1869)

<https://vimeo.com/552961855>