

# New Culture and Education Centre, Stratford Waterfront, London

Production of Exchange

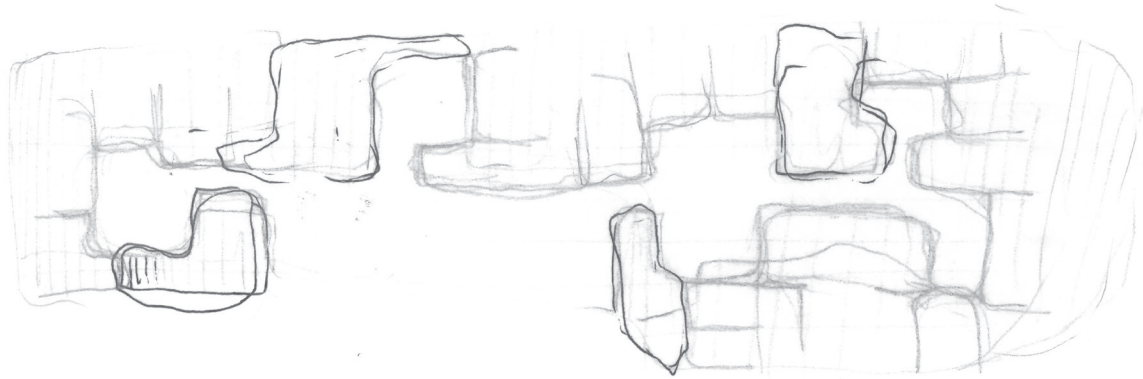





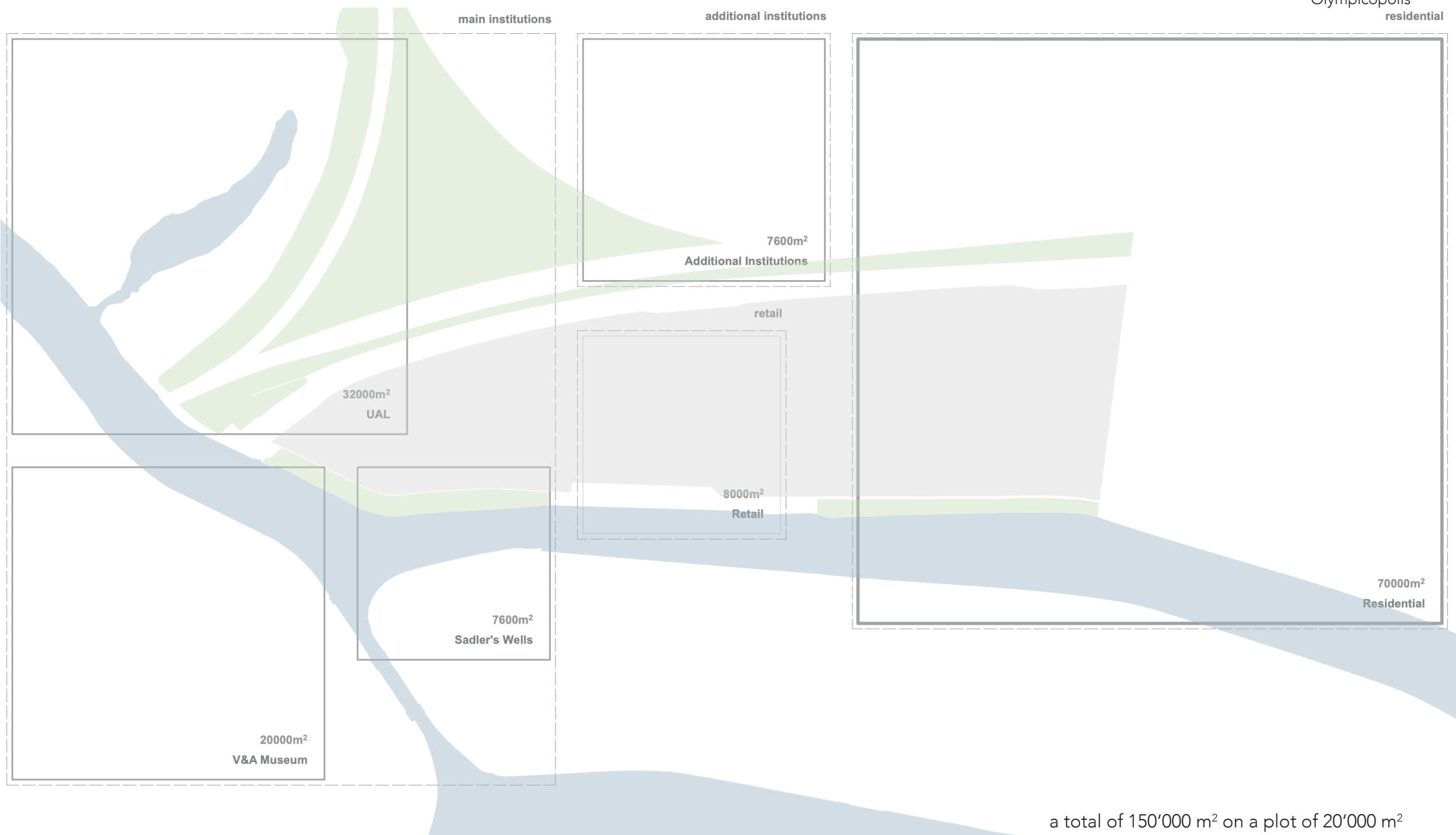

# Institutions + Brief Uses

Olympicopolis residential



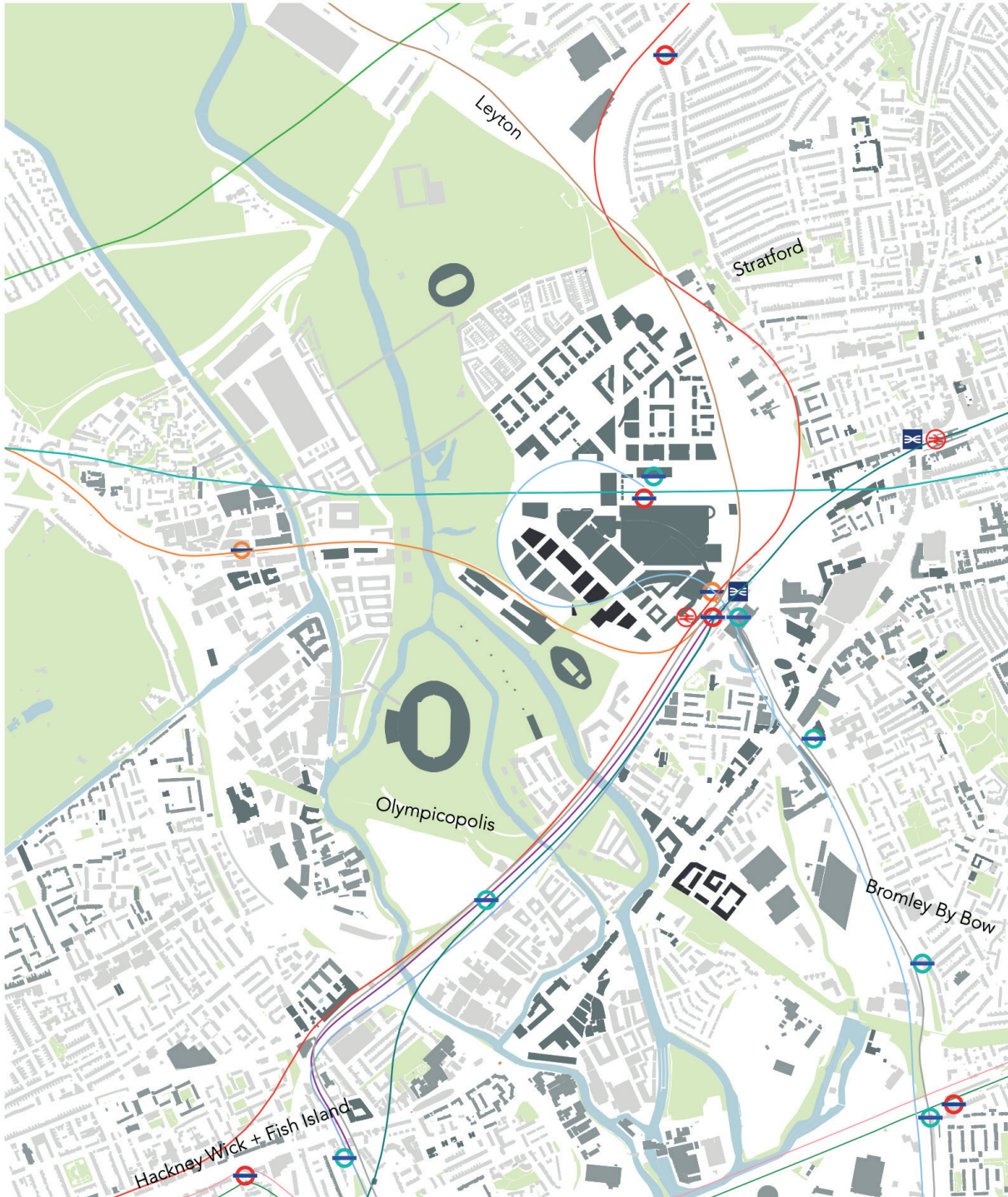

a total of 150'000 m<sup>2</sup> on a plot of 20'000 m<sup>2</sup>



-  tube station
-  Central line
-  District line
-  Hammersmith and City line
-  Jubilee line

-  DLR station
-  Docklands Light Railway 1
-  Docklands Light Railway 2

-  London overground station
-  London Overground

-  railway station
-  railnetwork
-  crossrail

-  Crossrail 1
-  High speed 1
-  High speed 2

-  2 - 3 Storeys
-  4 - 6 Storeys
-  7 - 10 Storeys
-  11 + Storeys

-  Green Spaces
-  City of London
-  Water Bodies

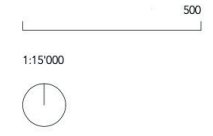

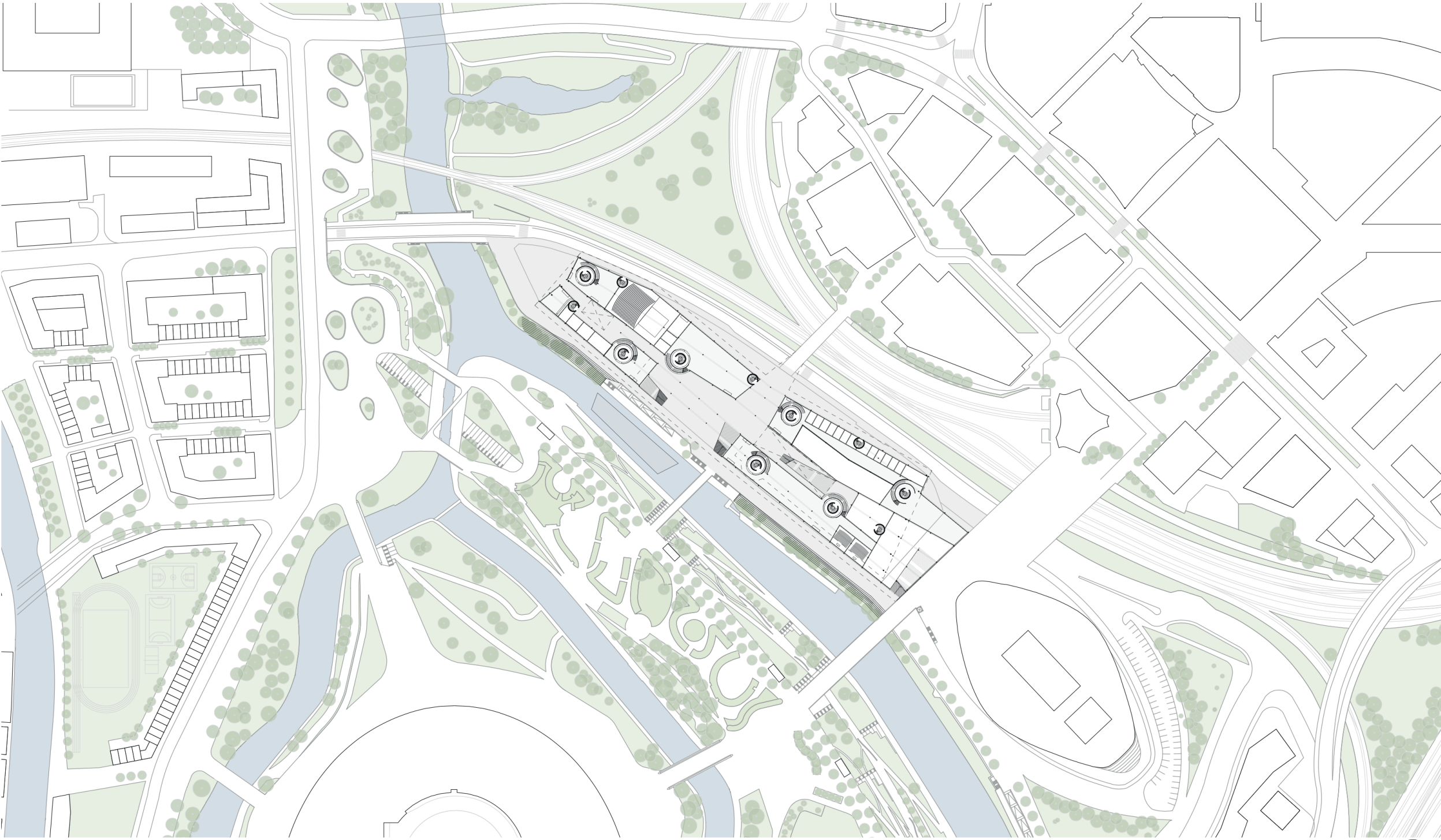

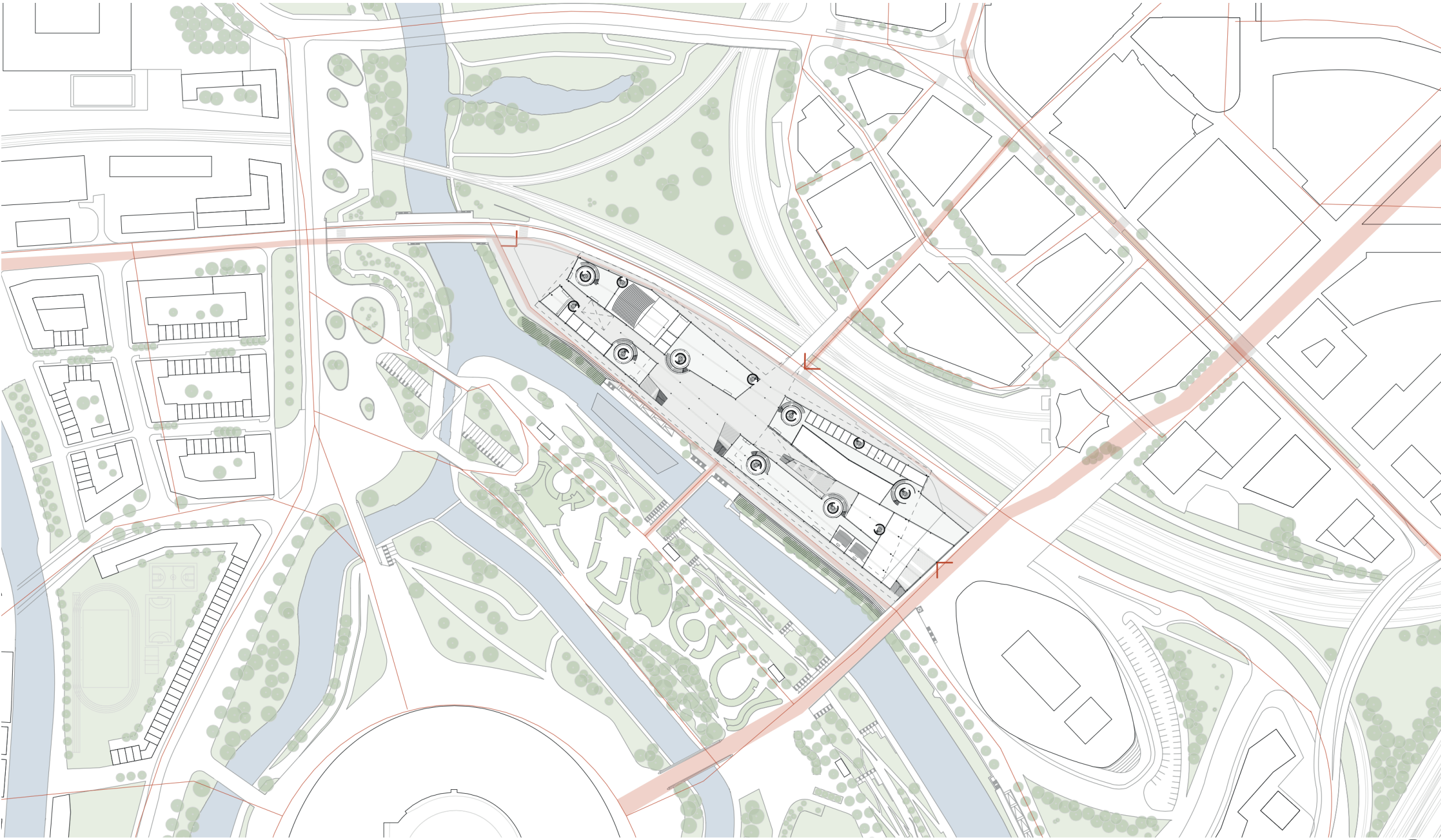



# Circulation Hierarchy

horizontal - vertical

-  horizontal - public - outside - stay
-  vertical - institutional - inside - common
-  vertical - residential - inside - way home, fire

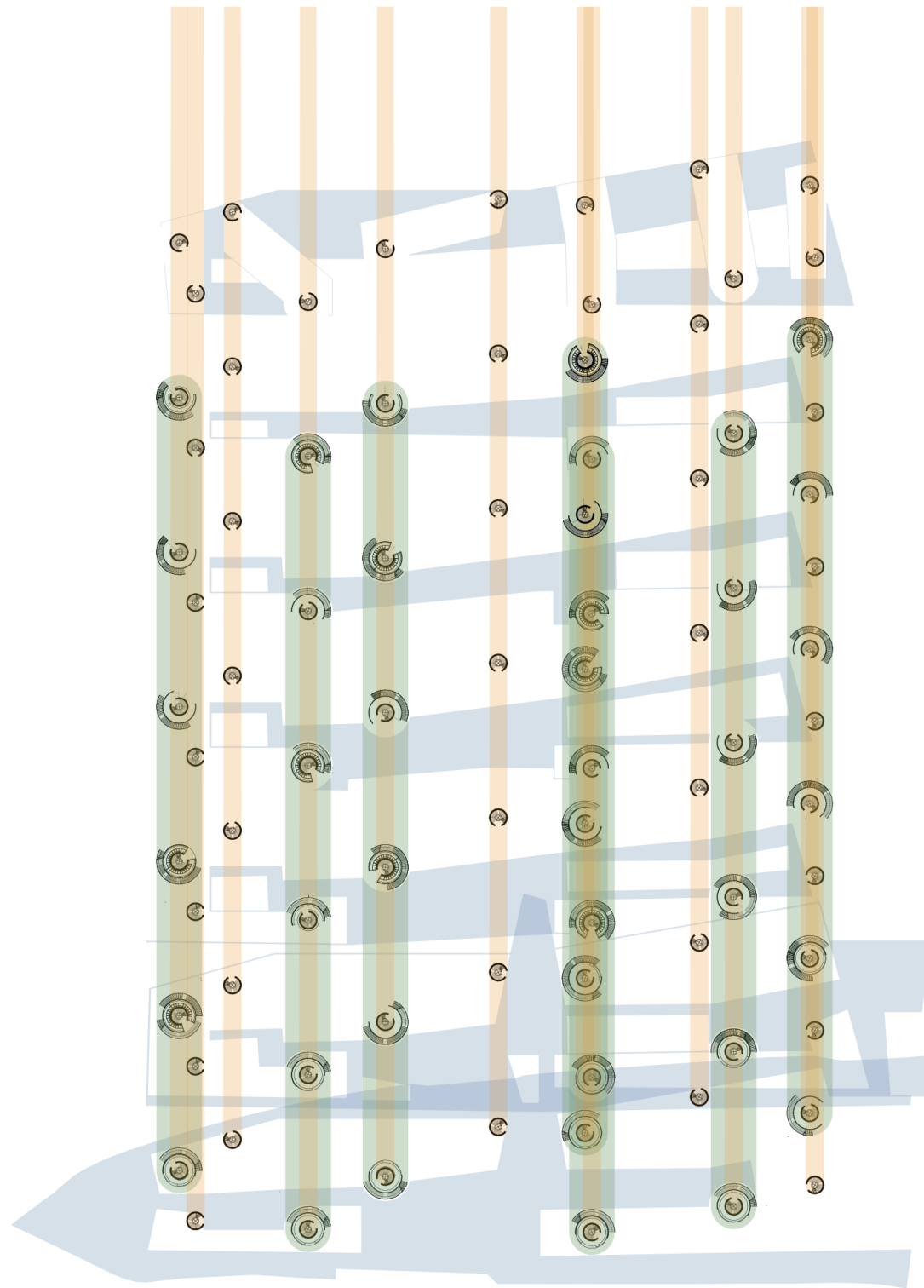

0 | | | | 100

MST 1:2500





Circulation Hierarchy  
horizontal - vertical

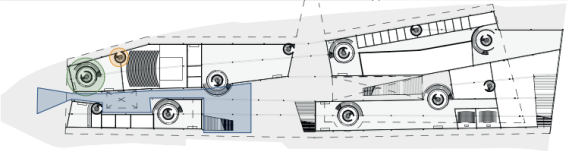
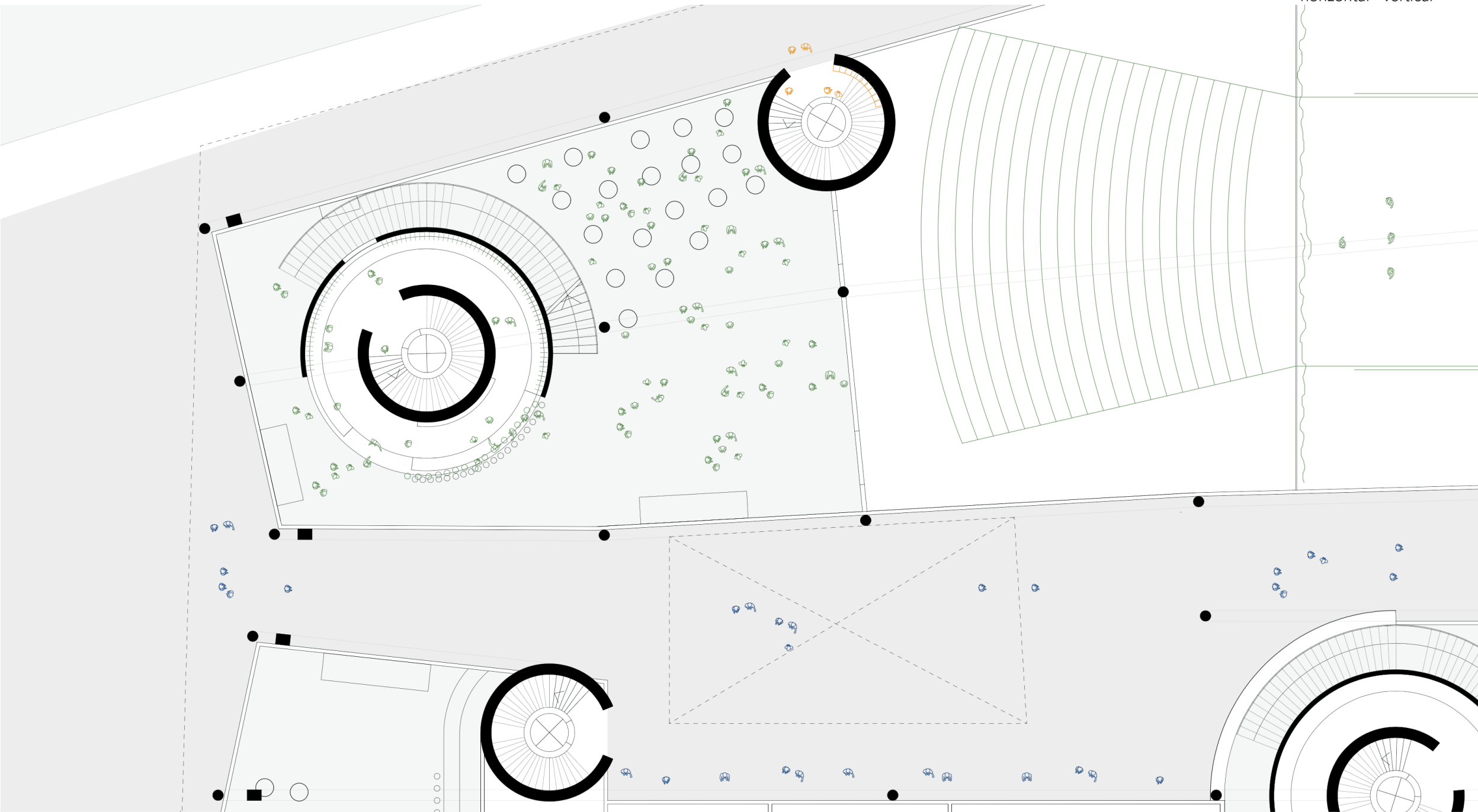

0 ——— 5

MST 1:250



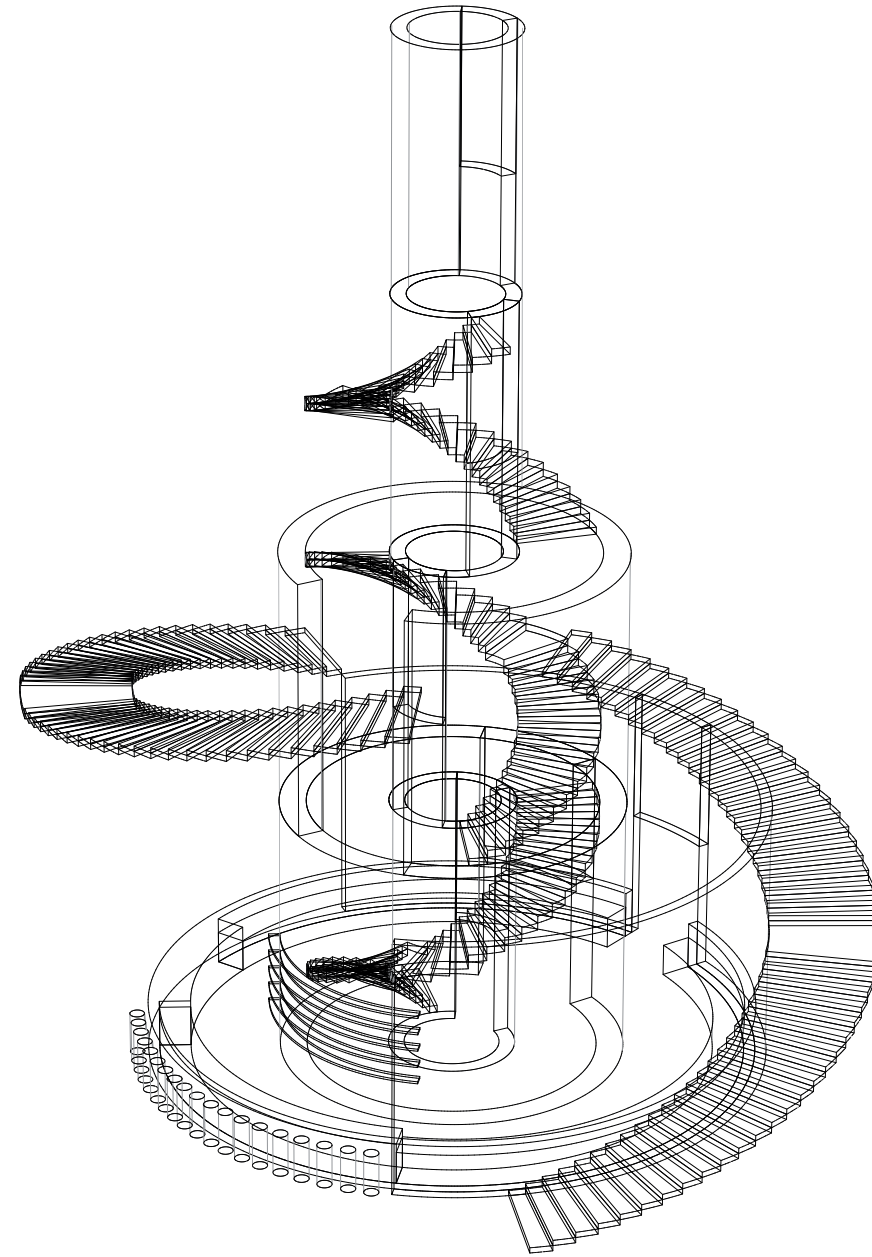

terraces - outside  
built volume - inside

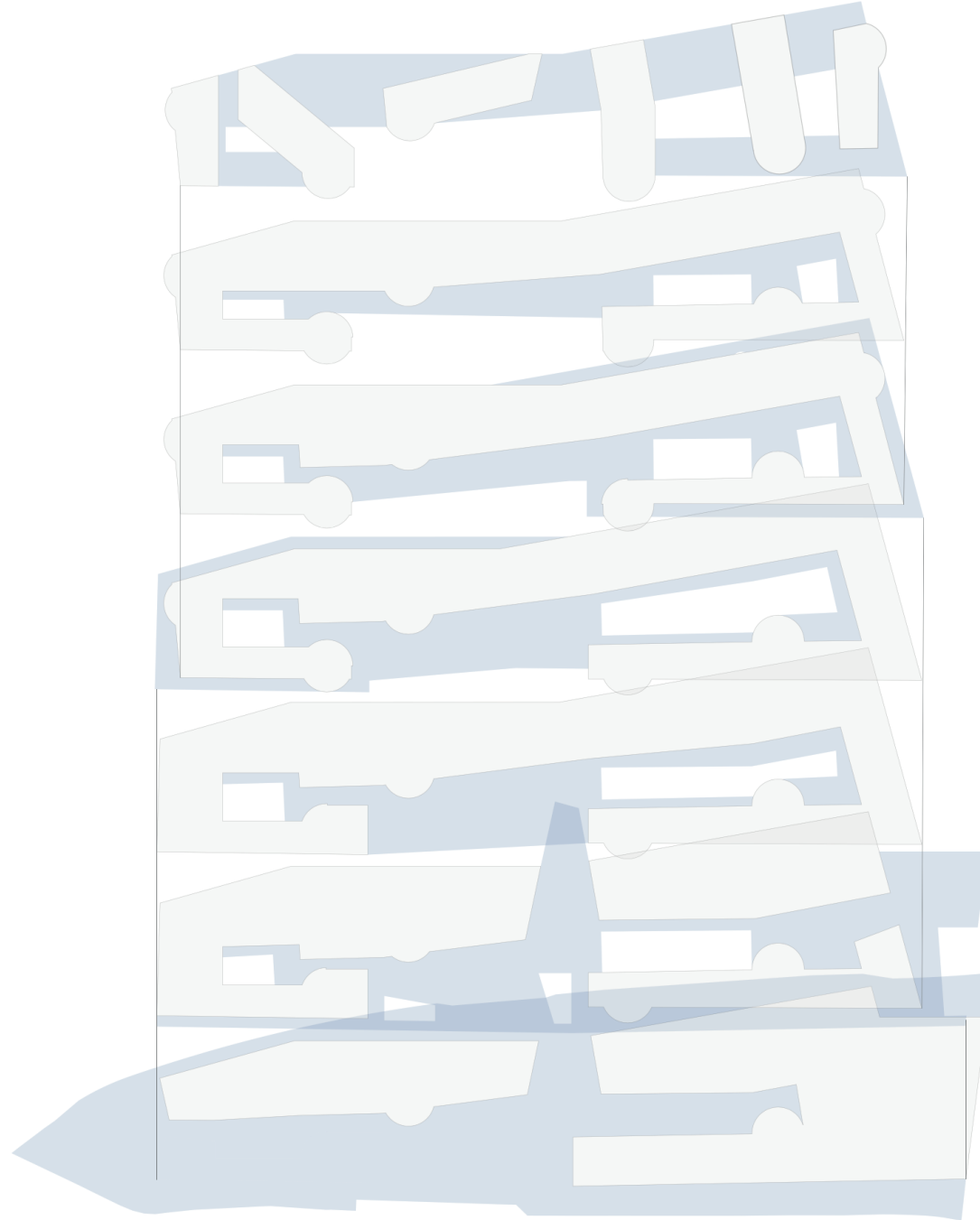

MST 1:2500





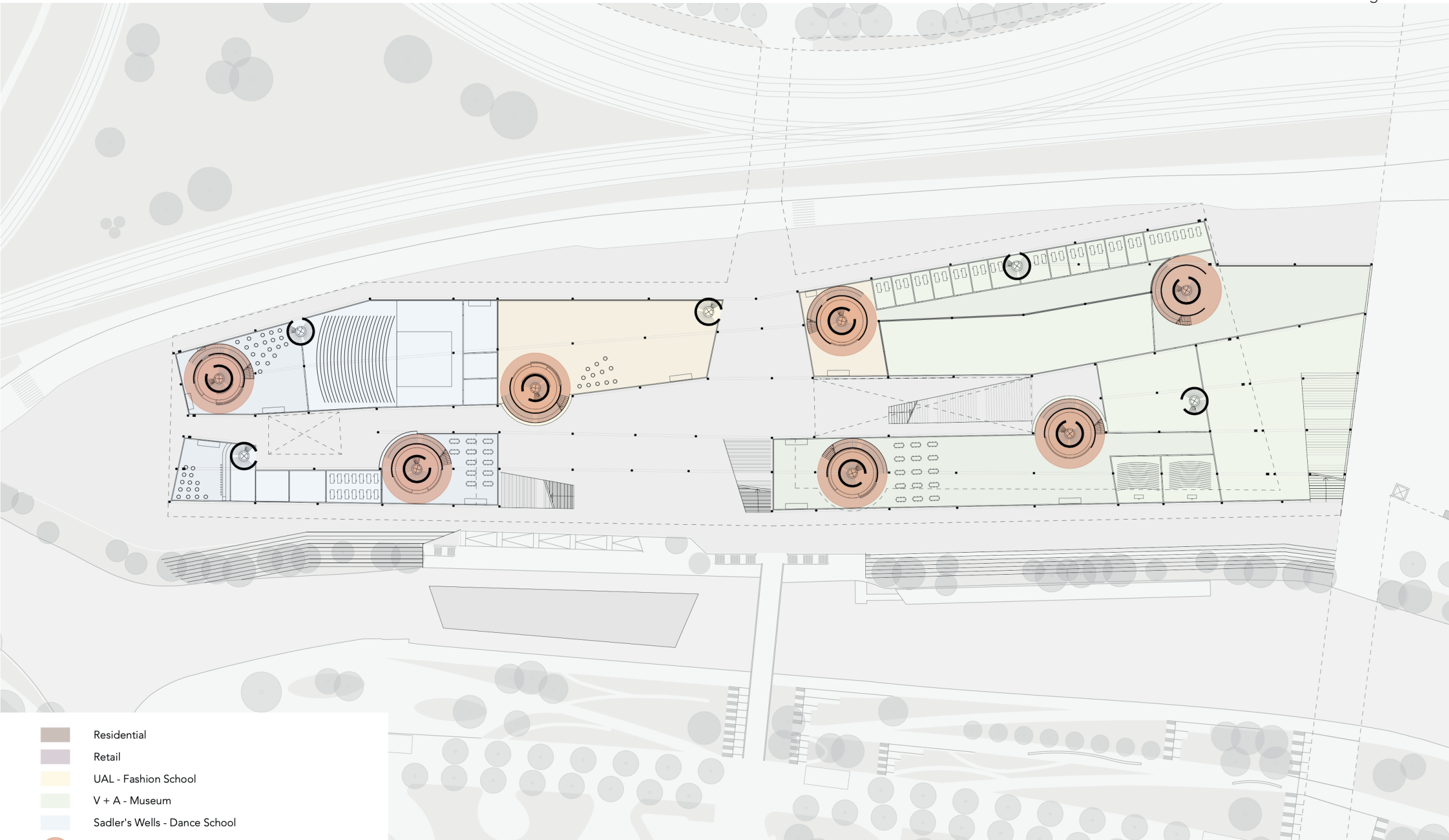

- Residential
- Retail
- UAL - Fashion School
- V + A - Museum
- Sadler's Wells - Dance School
- Communal Circulation Spaces - Additional Institutions

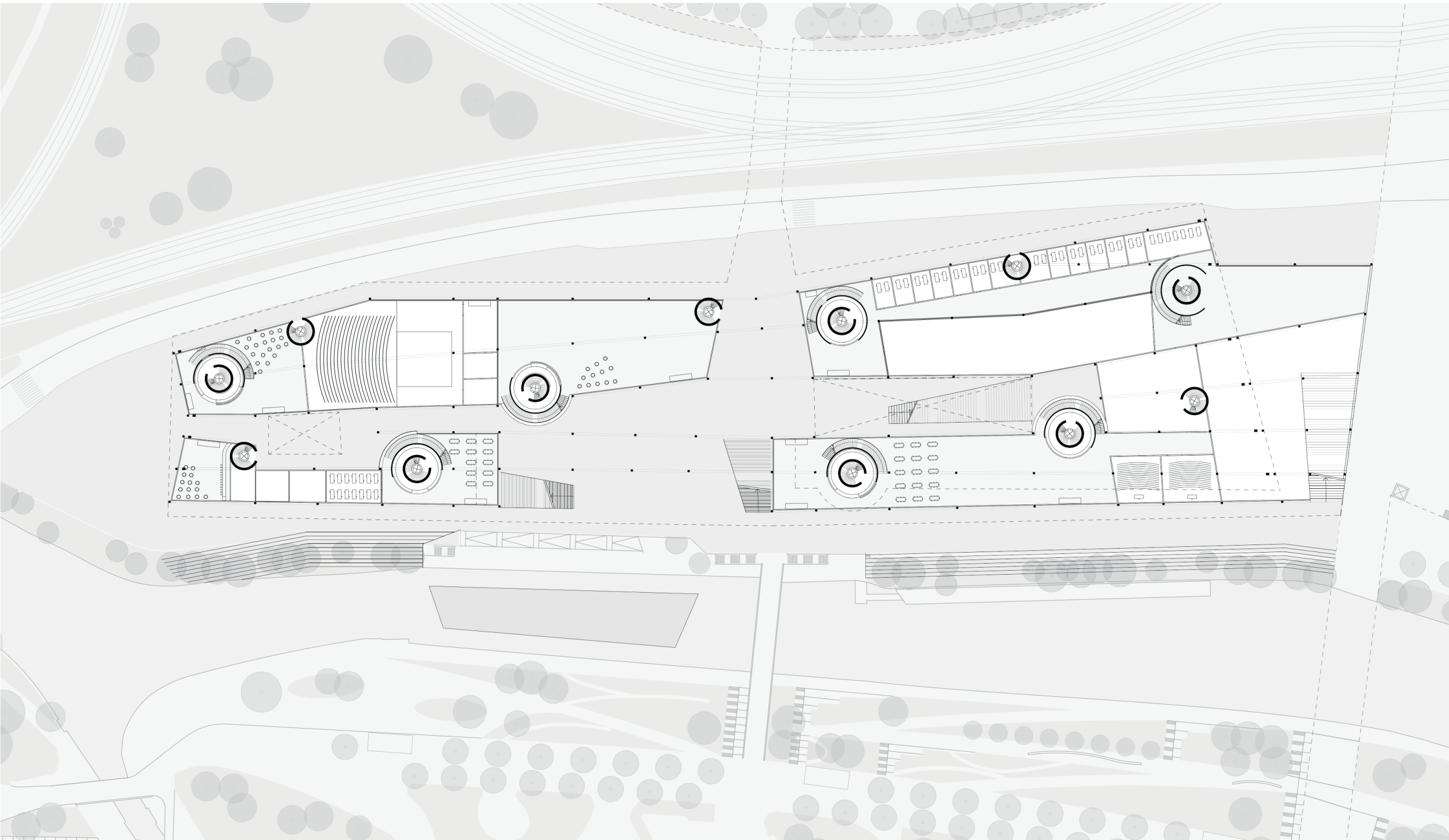

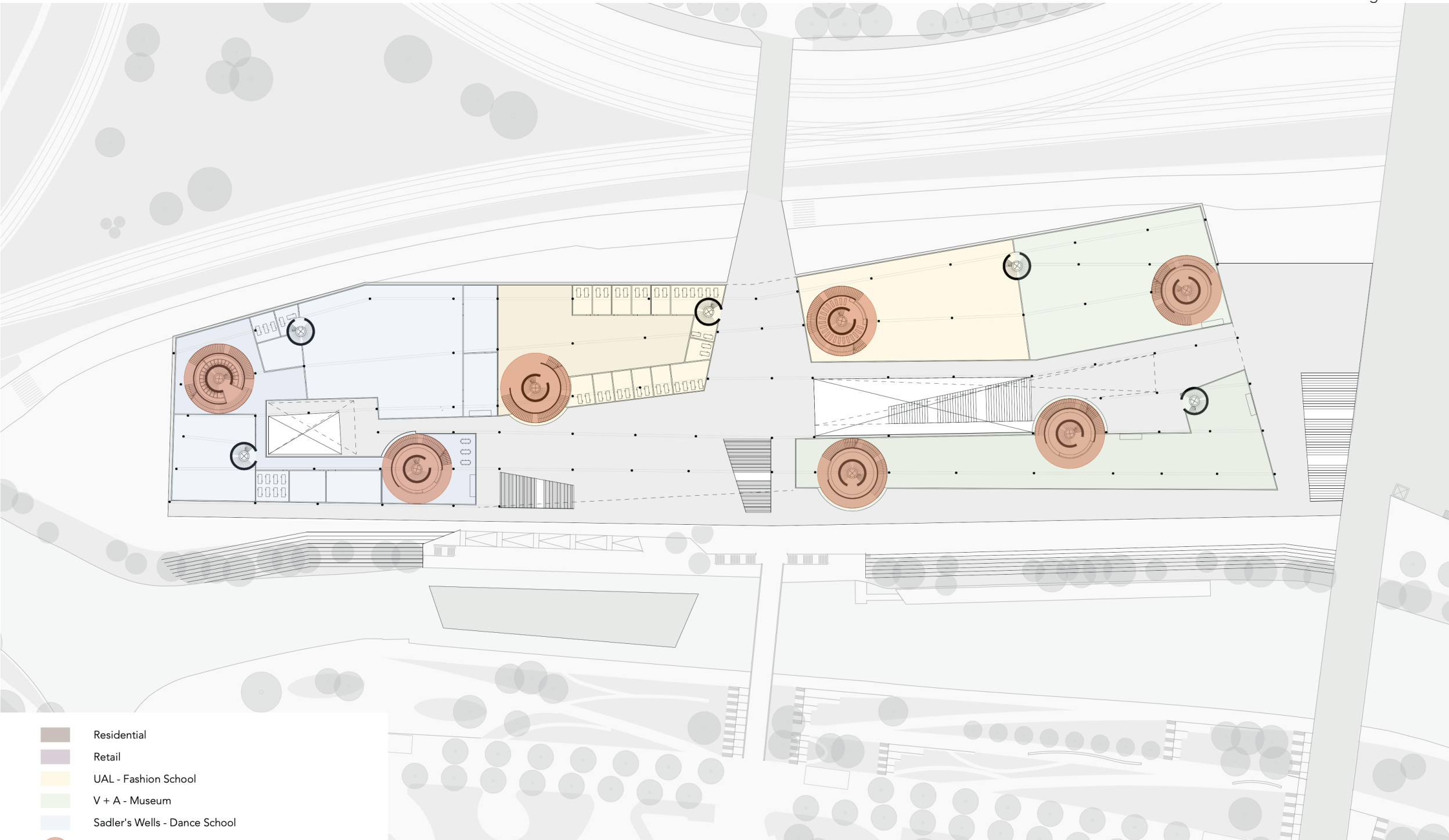

- Residential
- Retail
- UAL - Fashion School
- V + A - Museum
- Sadler's Wells - Dance School
- Communal Circulation Spaces - Additional Institutions

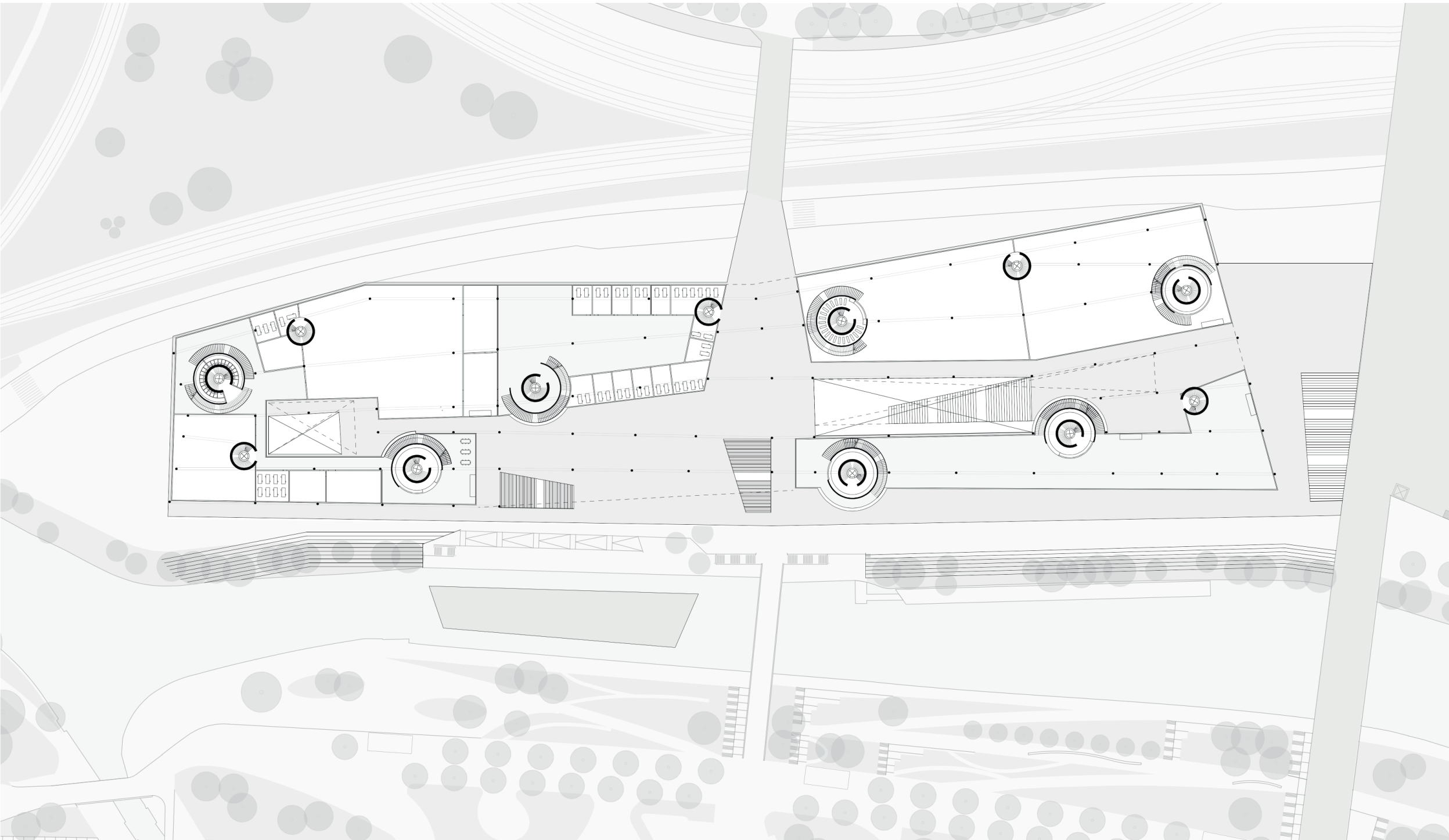



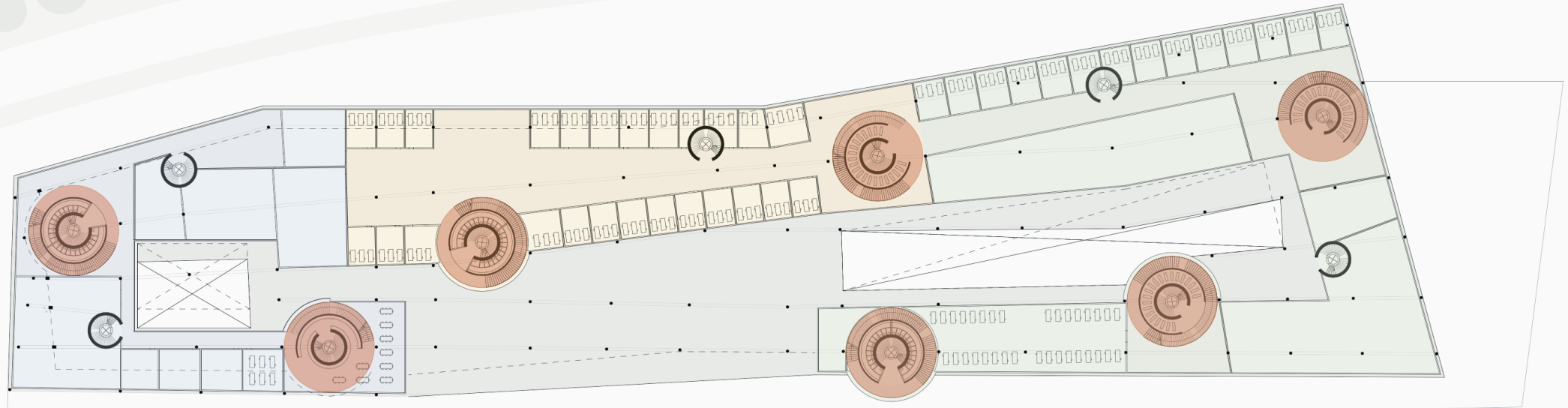

- Residential
- Retail
- UAL - Fashion School
- V + A - Museum
- Sadler's Wells - Dance School
- Communal Circulation Spaces - Additional Institutions



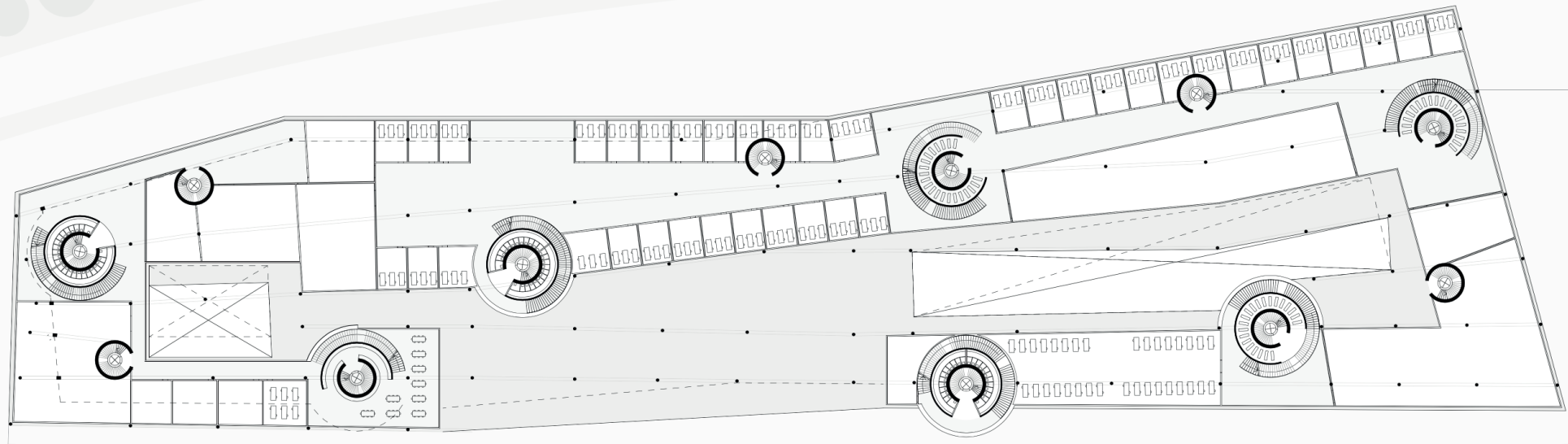

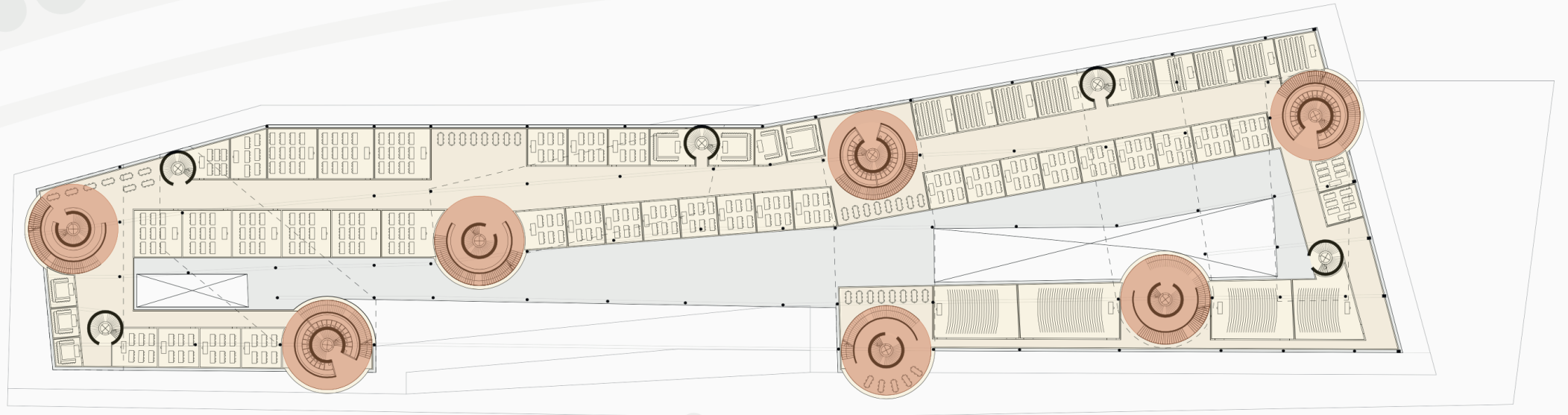

- Residential
- Retail
- UAL - Fashion School
- V + A - Museum
- Sadler's Wells - Dance School
- Communal Circulation Spaces - Additional Institutions



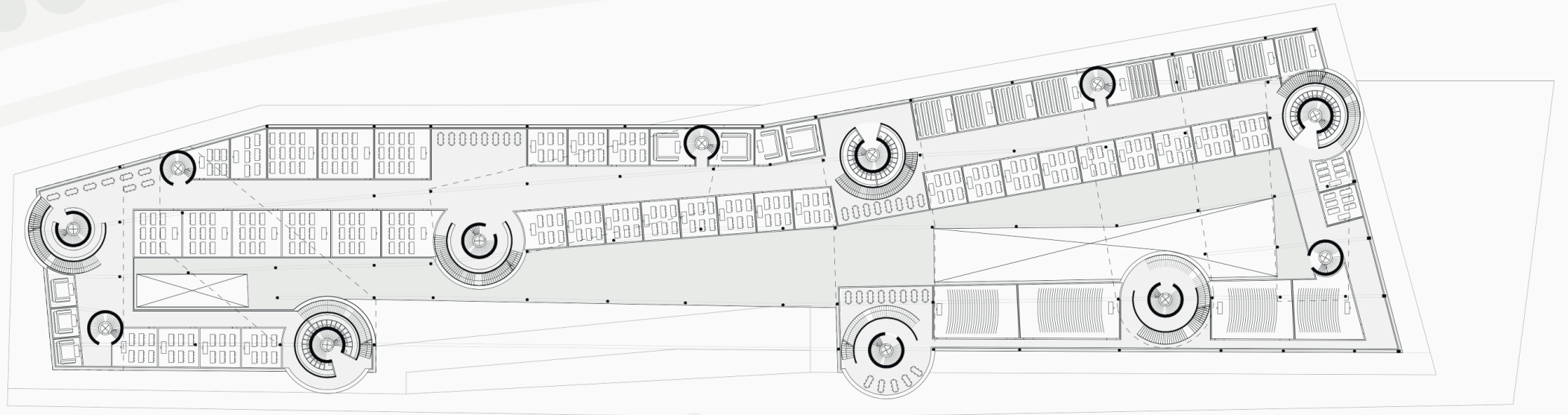

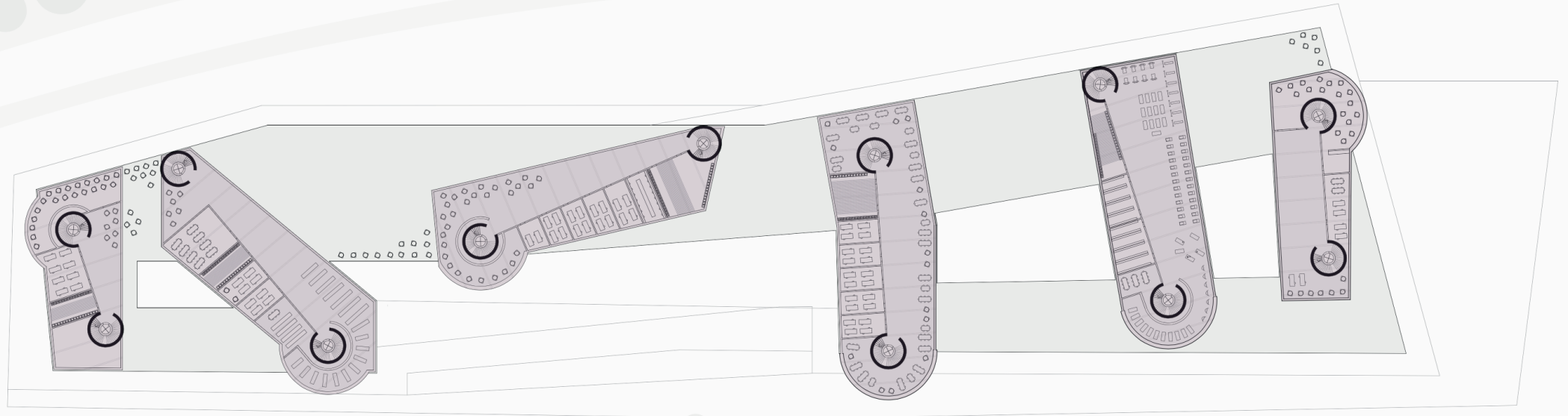

- Residential
- Retail
- UAL - Fashion School
- V + A - Museum
- Sadler's Wells - Dance School
- Communal Circulation Spaces - Additional Institutions



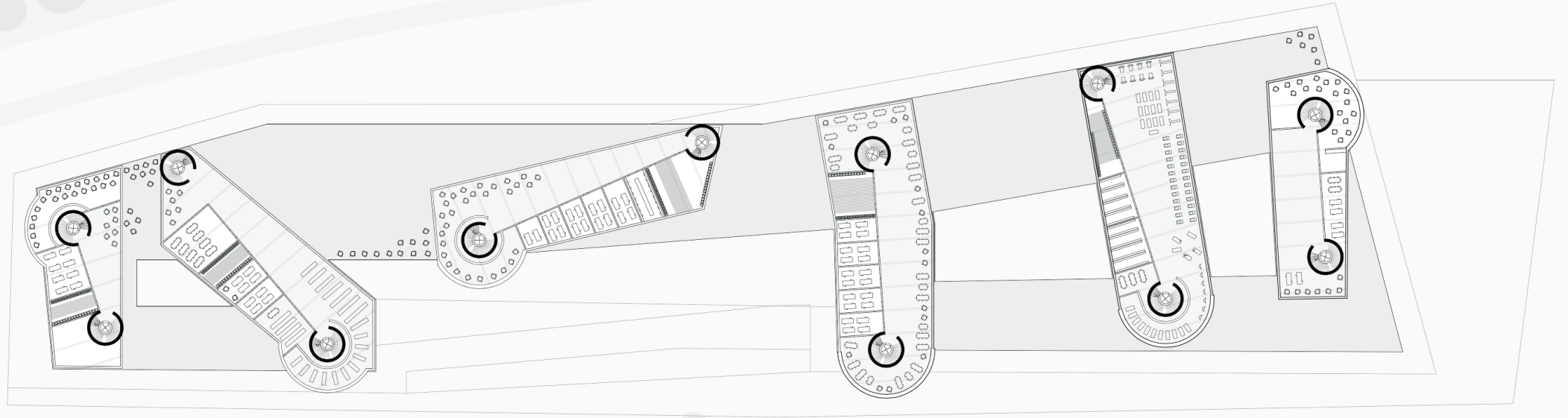

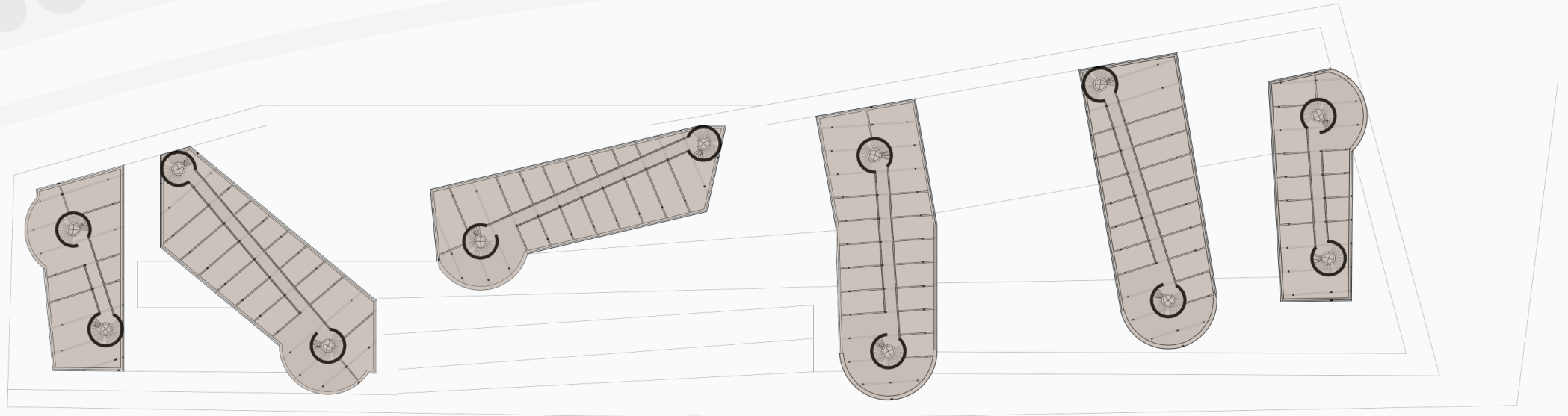

- Residential
- Retail
- UAL - Fashion School
- V + A - Museum
- Sadler's Wells - Dance School
- Communal Circulation Spaces - Additional Institutions



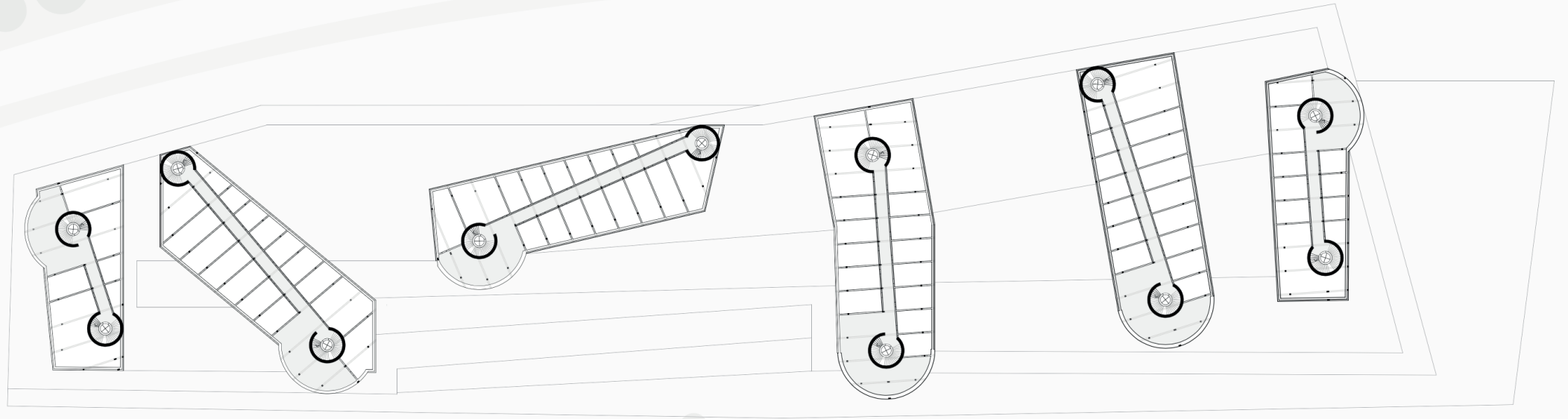



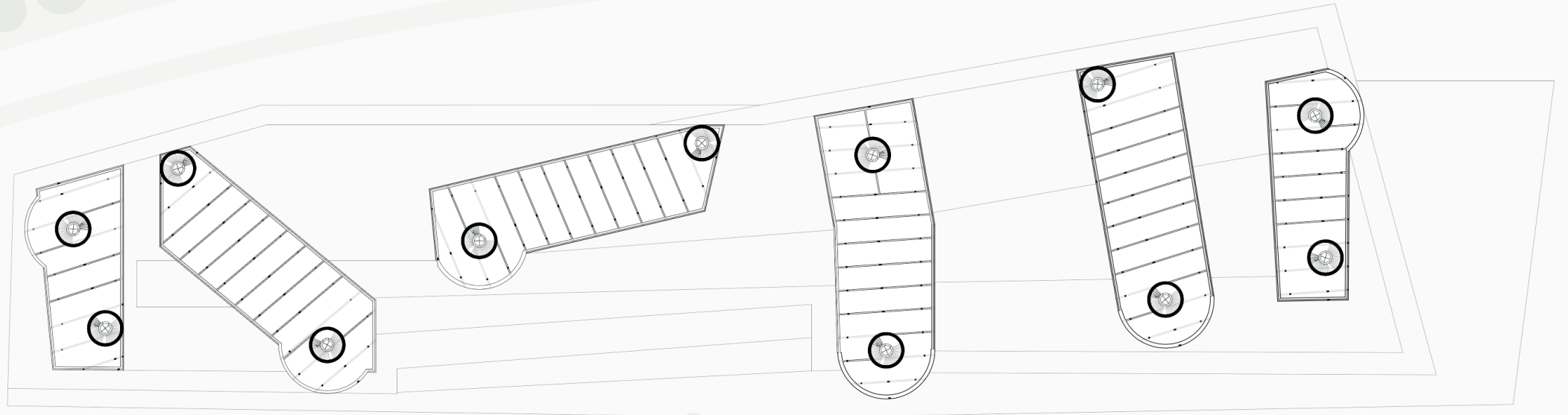

- terraces - public - outside
- shared spaces - institutional/communal - inside

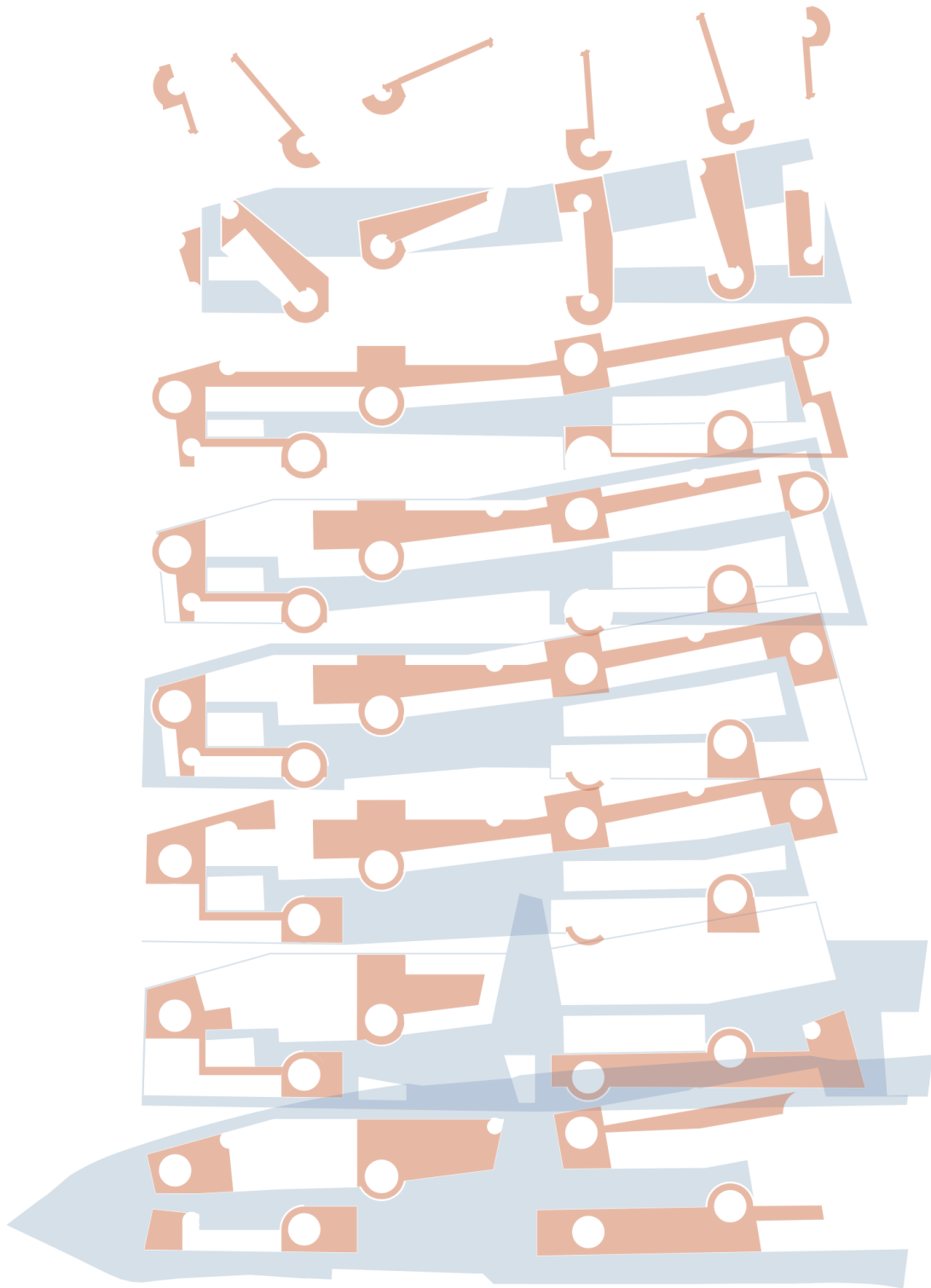

MST 1:2500



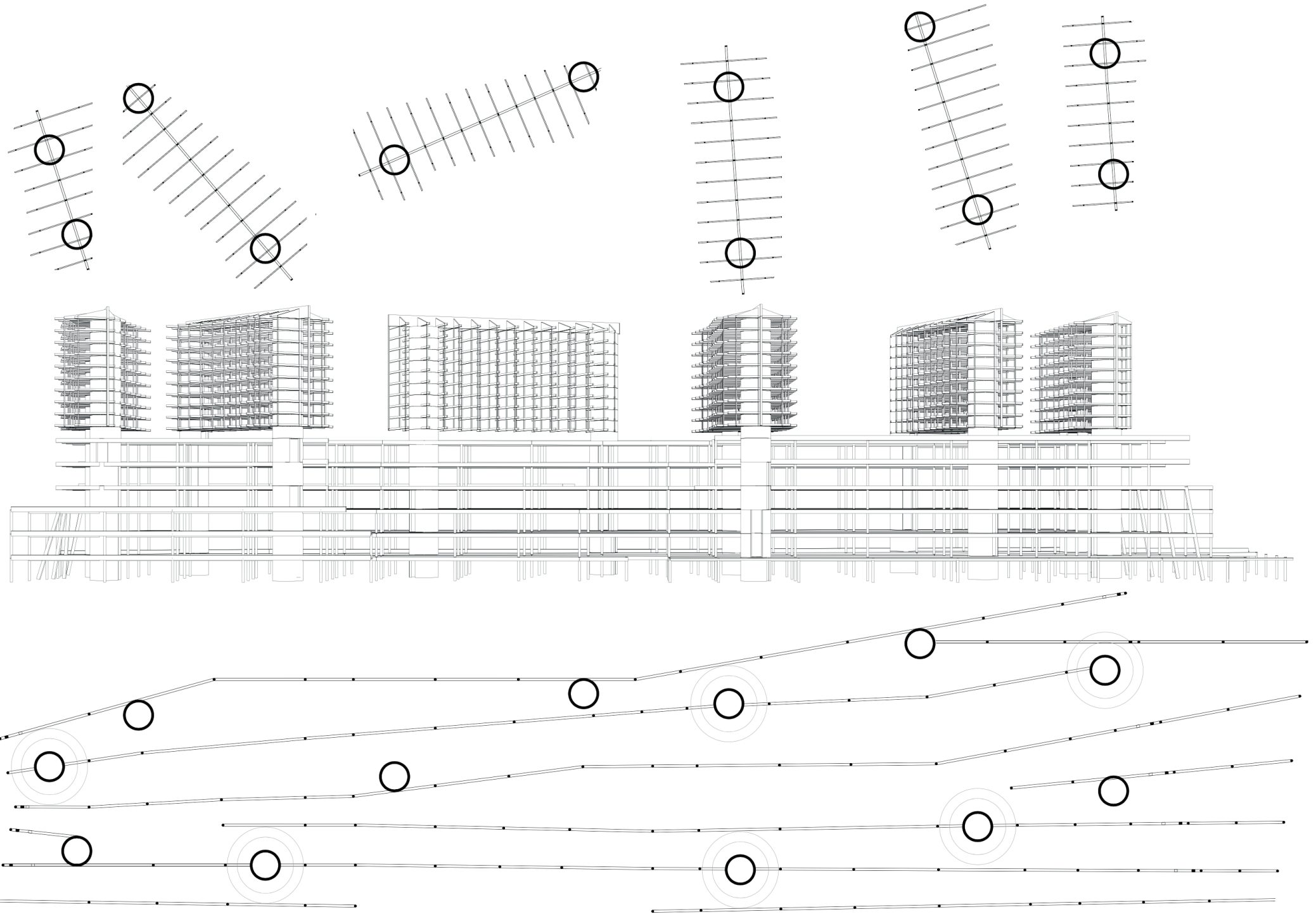

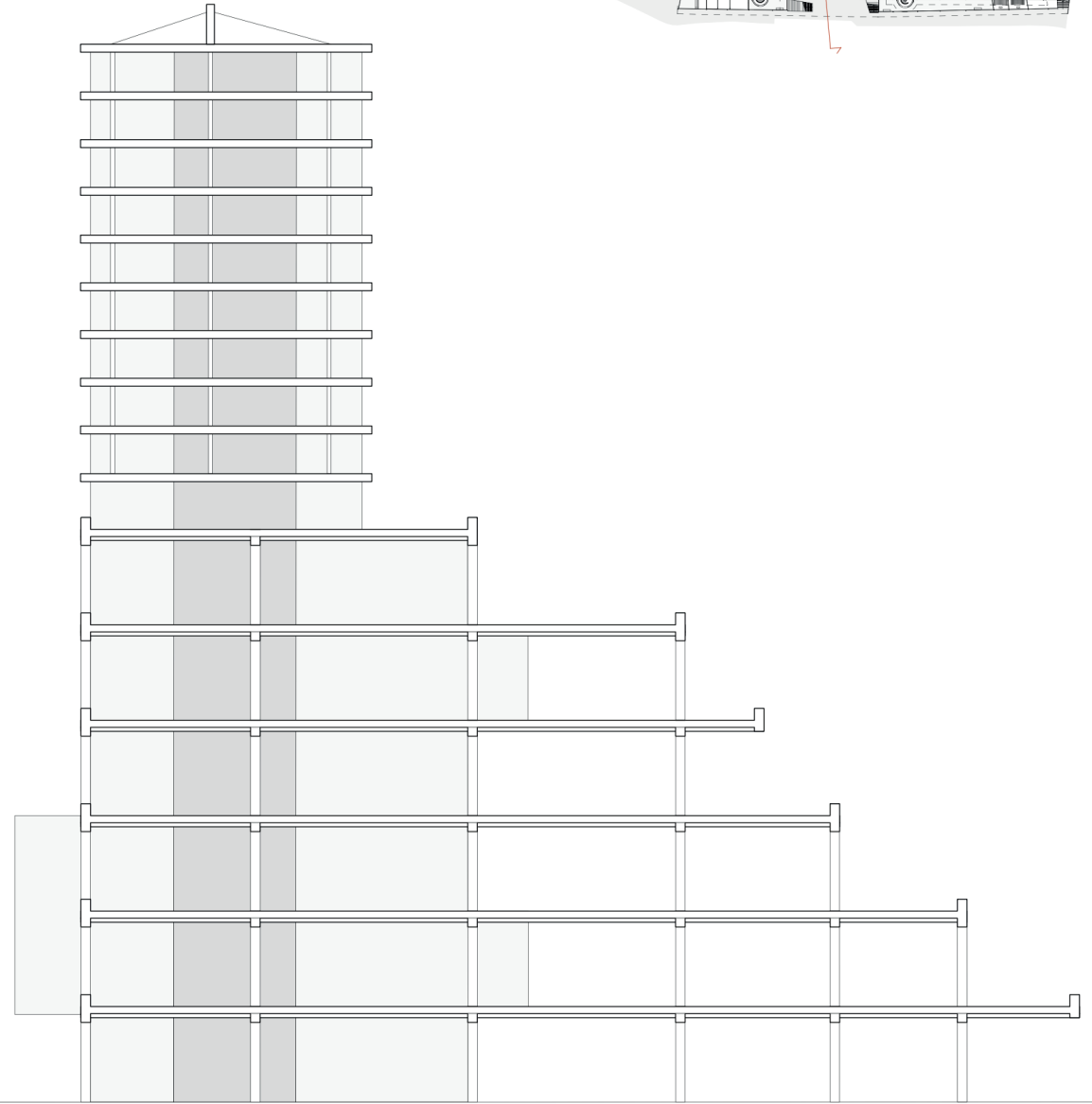
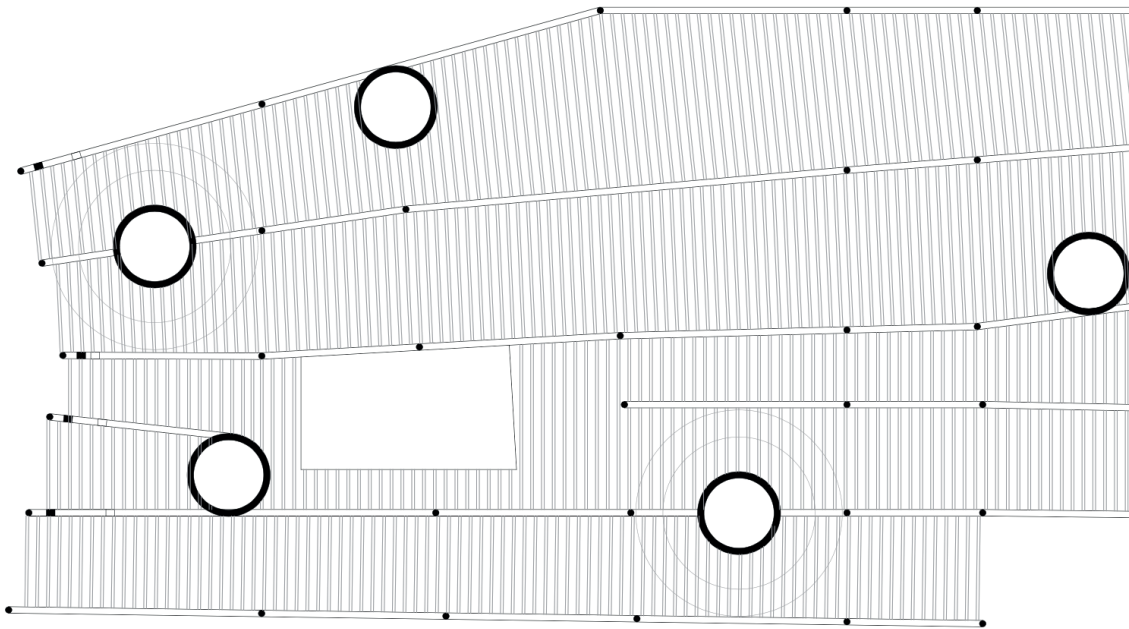
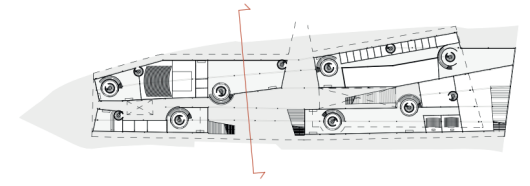
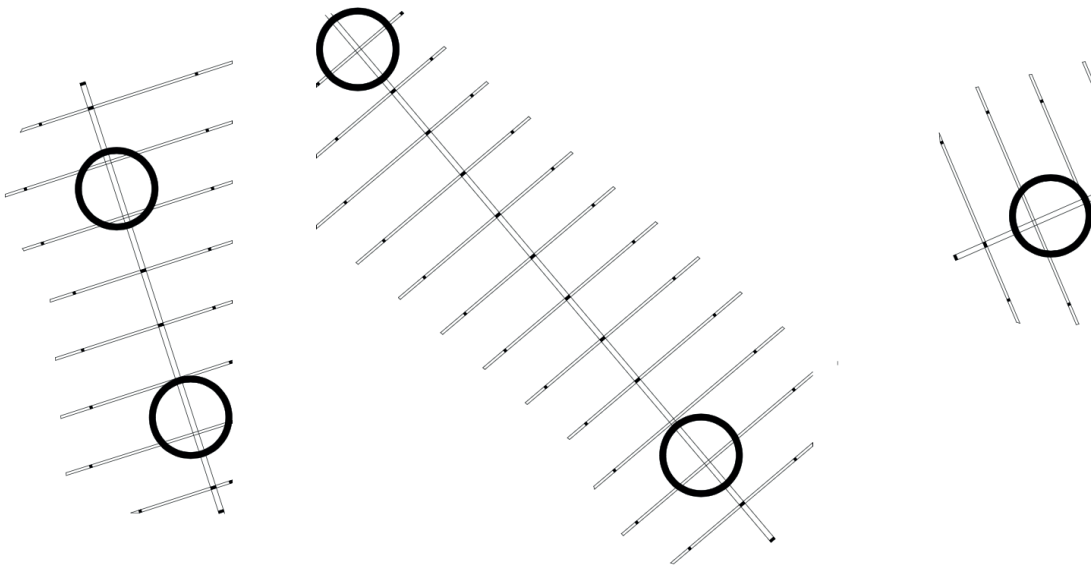

0 5 10 20 MST 1:700



0 5 10 20 MST 1:450

