

KUNSTHAUS GLARUS

MARIUS MUSZYNSKI

UNSCHÖNE MUSEEN / FS 23

PROFESSOR ADAM CARUSO & GTA EXHIBITIONS

ETH ZÜRICH

Impressum

The copyright for the texts lies with the authors

The copyright for the illustrations lies with the
photographers / owners of the picture rights

16. October 2023

Master Thesis

Eidgenössische Technische Hochschule Zürich

Department Architecture

Chair of Architecture and Construction

Prof. Adam Caruso

Author

Marius Norbert Muszynski

Supervision

Emilie Appercé

Geraldine Tedder

Adam Caruso

Contact information

Marius Norbert Muszynski

Stud. Nr. 18-929-158

mariusmu@student.ethz.ch

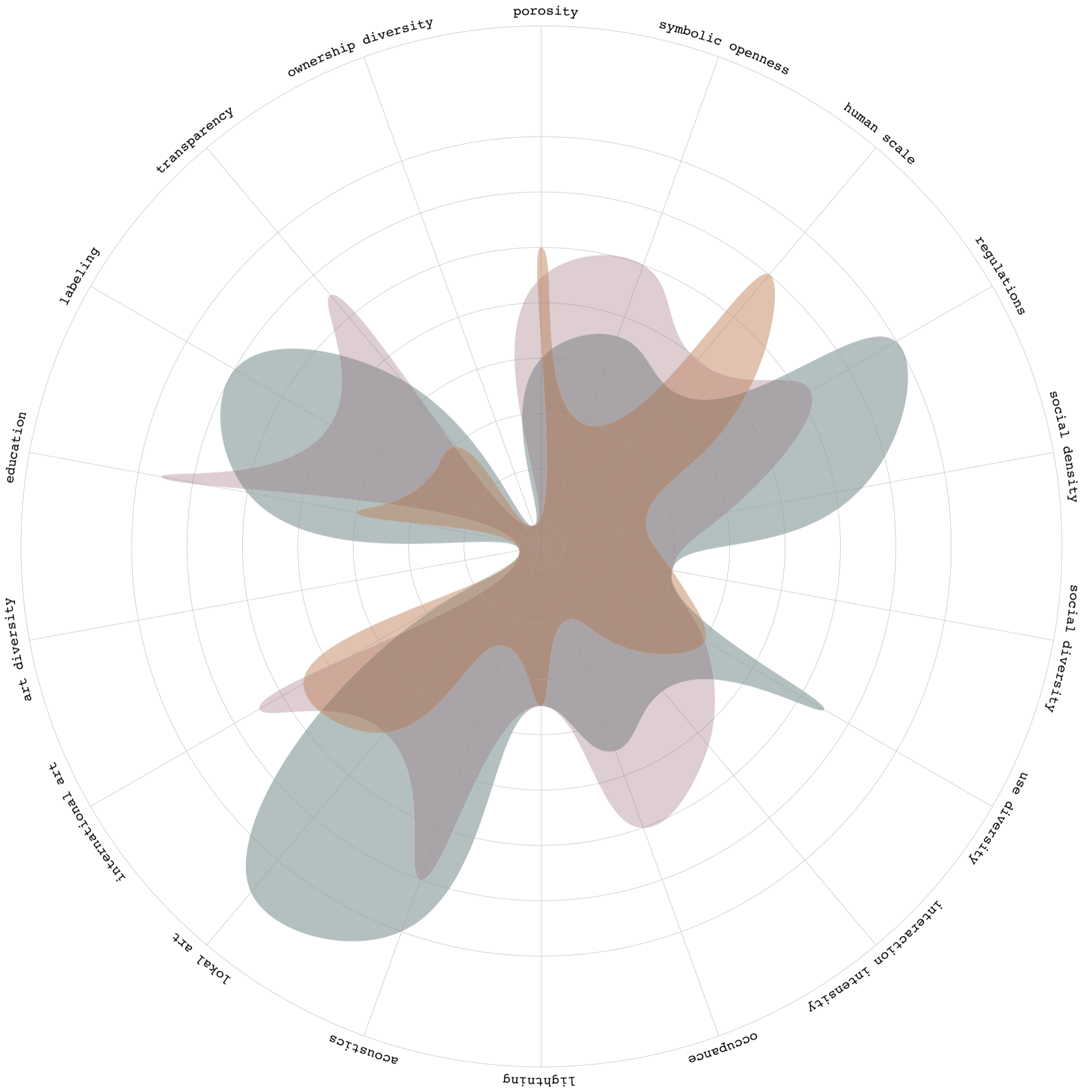

- Kunstmuseum Chur | Donnerstag 10-13:00
- Kunstmuseum St.Gallen | Freitag 10-14:30
- Kunsthaus Glarus | Donnerstag 14-16:30

The starting point for the analysis of the Kunsthhaus Glarus was the visit to the three museums Kunsthhaus Glarus, Kunstmuseum Chur and Kunstmuseum St.Gallen. The first subjective impressions were recorded in the diagram on the left, based on certain influencing factors. In principle, not only the negative was sought, but also what these museums are already doing well. This comparison serves to learn from other institutions and to crystallise the virus that surrounds the unattractive museums.

Introduction

The research part about the Kunsthauus Glarus focuses on the three themes Allegory, Access and Exclusion. The overall theme Enough is taken into account and partially linked, especially to the idea of sustainability. A building is sustainable if we use environmentally friendly materials, but this is only one side of the coin. In the long term, a building is only sustainable if the local population can identify with the building through memories, and thus the population has an incentive to preserve the building for future generations, even if its function changes. Another point of sustainability of a building is its utilization, because actually we do not need more built mass but we need to programmatically manage the stock so that we can cover all our needs. This is mainly done through a high utilization of the building and requires an openness to diverse programs. The diagram on the right shows a glossary of the different links and dependencies of the single-cell sub-themes. In the subchapters that follow, this will be dealt with in greater depth. It can be said that the Kunsthauus Glarus tries to appeal to the local population, but this is not easy, because the architecture is mainly influenced by references to modern buildings in Scandinavia, and the financial resources are rather limited. Furthermore, the rooms were designed for specific exhibitions, which makes it not always easy to play them. Moreover, Glarus is located in a valley that is a dead end, which means that tourists rarely come here to visit the museum, especially if you think about the density of museums in Switzerland, as well as the distances, you can reach almost all major cities in German-speaking Switzerland within an hour. This leads to a struggle for visitors, which does not help the healing of the museums. Nevertheless, there are bottom up developments from the population in Glarus that claim the Kunsthauus for other uses. For example, helping children learn to read every Wednesday afternoon.



EXCLUSION

KUNSTHAUS GLARUS

MARIUS MUSZYNSKI

```

1 <!DOCTYPE html>
2 <html lang="de-CH">
3   <head>
4     <title>Archiv</title>
5     <meta name="generator" content="SilverStripe - http://silverstripe.org" />
6     <meta http-equiv="Content-type" content="text/html; charset=utf-8" />
7     <link rel="alternate" type="text/html" title="Archive" hreflang="en-US" href="https://kun
8     <link rel="alternate" type="text/html" title="Archiv" hreflang="de-CH" href="https://kuns
9
10    <base href="https://kunsthausglarus.ch/"><!--[if lte IE 6]></base><![endif]-->
11    <link rel="stylesheet" type="text/css" href="themes/khgl/css/main.min.css?16442395
12    <meta name="viewport" content="width=device-width, initial-scale=1, maximum-sca
13    <link rel="shortcut icon" href="/favicon.ico" type="image/x-icon">
14  </head>
15  <body class="BcExhibitionListPage">
16    <div id="wrap">
17      <!-- #main -->
18      <div class="scroll-panel" id="main">
19        <div class="scroll-panel-inner">
20          <div class="inner-content">
21
22            <div class="swipescreen-icon">
23              <svg version="1.1" id="Layer_2" xmlns="http://www.w3.org/2000/svg"
24                width="18.72px" height="18.716px" viewBox="0 0 18.72 18.71
25 <rect x="0.463" y="0.221" fill="#FFFFFF" width="18" height="18"/>
26 <polyline fill="none" stroke="#231F20" points="4.463,8.721 12.921,8.721 4.463,8.721 ,/
27 <polyline fill="none" stroke="#231F20" points="9.947,6.05 13.463,8.704 9.947,11.357 ,/
28 </svg>
29
30            <div id="layout"><div id="onpage-nav">
31 <div id="breadcrumb">
32   (<span class="parent-page">Ausstellungen</span> / Archiv)
33 </div>
34 <nav>
35   <ul>
36     <li class="link"><a href="/de/ausstellungen/aktuell/" title="Aktuell">Aktuell</a>
37
38     <li class="link"><a href="/de/ausstellungen/jahresprogramm/kunstschaffen-glarus
39
40     <li class="current"><a href="/de/ausstellungen/archiv/" title="Archiv">Archiv</a>
41
42   </ul>
43 </nav>
44 </div>
45
46     <nav id="archive-nav" class="year-nav" data-current-year="1995">
47 <ul>
48   <li class="">
49     <a href="/de/ausstellungen/archiv/year/2023" class="year-nav" data-item-selector
50 </li>
51   <li class="">
52     <a href="/de/ausstellungen/archiv/year/2022" class="year-nav" data-item-selector
53 </li>
54   <li class="">
55     <a href="/de/ausstellungen/archiv/year/2021" class="year-nav" data-item-selector
56 </li>
57   <li class="">
58     <a href="/de/ausstellungen/archiv/year/2020" class="year-nav" data-item-selector
59 </li>
60   <li class="">
61     <a href="/de/ausstellungen/archiv/year/2019" class="year-nav" data-item-selector
62 </li>
63   <li class="">
64     <a href="/de/ausstellungen/archiv/year/2018" class="year-nav" data-item-selector
65 </li>
66   <li class="">
67     <a href="/de/ausstellungen/archiv/year/2017" class="year-nav" data-item-selector
68 </li>
69   <li class="">
70     <a href="/de/ausstellungen/archiv/year/2016" class="year-nav" data-item-selector
71 </li>
72   <li class="">
73     <a href="/de/ausstellungen/archiv/year/2015" class="year-nav" data-item-selector
74 </li>

```

Eidgenössische Stipen

02.07.–10.09.1995

Helen Chadwick – POE

29.06.–10.09.1995

Peter Britt – Ein Obst
>

14.04.–18.06.1995

Sammlung Othmar Huk

14.04.–18.06.1995

Simone Ch. Wicki – Rö

14.04.–18.06.1995

Sammlung Marc Egger
>

29.01.–02.04.1995

Annelies Strba – Bernh

29.01.–02.04.1995

Meisterwerke aus der S
Kunstvereins

Kunsthaus Glarus exclusion through time and space explores the connections between contemporary exhibitions, collections, the local, the Swiss and the international. It documents the program of Kunsthaus Glarus over the last 29 years and categorizes it into Unknown, Collections and Contemporary Exhibitions. In these 3 categories, the focus is on the type of program (collection or contemporary exhibitions), as well as whether one category is displaced from another. Does this give rise to a call for more space, other spatial subdivisions, or just a programmatic change. In a second step the connection of the artists to the place Glarus, the local and its population is examined, by dividing all artists of the Contemporary Exhibitions into International Artists, National Artists and Local Artists. Finally, the question arises to what extent a more local or international orientation of the invited artists influences the connection and identification of the local population to the Kunsthaus Glarus. The presentation of the list itself deconstructs the polished website of the Kunsthaus Glarus by making the website source code visible to everyone, which is otherwise hidden behind the images, texts and icons. The selection of the artists is largely based on the financial resources of the Kunsthaus Glarus, as well as the director. This has emerged during the discussions with Melanie Ohnemus and Judith Welter. The influences of the single-cell directors can also be well understood in the list by the small changes in which artists are selected and how the exhibitions are organized.

No point indicates that the programme could not be clearly assigned to a category. This may be due to the fact that there was no information about the artists, that it was a mixture of contemporary art exhibition and works from the collection or that there were exhibitions that took place at several locations in Switzerland or Internationally and therefore the artists who exhibited their art at the Kunsthaus Glarus could not be clearly identified.

- The purple dot indicates that the exhibition is a collection. The artworks in the collection come either from the collection of the Glaner Kunstverein, from the estate of Gustav Schnellli, from the collection of Othmar Huber, from the collection of Marc Egger or from external collections that have been loaned for exhibition purposes.
- The blue dot indicates that it is a contemporary art exhibition. This can be an exhibition of only one artist or a group exhibition of different artists, as well as performances, concerts, etc.
- The yellow dot indicates that it is an International Artist who is involved in this exhibition. The determination of whether someone is local, Swiss or international is based on the person's place of birth, which also means that the person does not necessarily live in that place anymore. This division was made because a person's childhood memories continue to shape him or her into old age.
- The light pink dot indicates that the artist is local and is included in the exhibition. The determination of whether someone is local, Swiss or international is based on the person's place of birth, which also means that the person does not necessarily live in that place anymore. This division was made because a person's childhood memories continue to shape him or her into old age. It should be mentioned that several people are involved in the exhibition of Kunstschaftende im Glarus, ranging from artists from the region to private individuals. Since it was not possible to identify the person in the first 10 years, this specific exhibition was always based on the assumption of one local artist. However, this only minimally distorts the results, as this specific exhibition takes place for about 1 month at a time, while other artists exhibit at the Kunsthaus Glarus for the rest of the year.
- The pink dot indicates that it is a Swiss Artist who is involved in this exhibition. The determination of whether someone is local, Swiss or international is based on the person's place of birth, which also means that the person does not necessarily live in that place anymore. This division was made because a person's childhood memories continue to shape him or her into old age.

1995

Total number of programs: 9

Exhibitions by contemporary artists: 5 (55.6%)

Exhibitions of the collection: 3 (33.3%)

Unkown category: 1 (11.1%)

Total number of participating artists in exhibitions: 6

International artist: 1 (16.7%)

Lokal artist: 2 (33.3%)

Swiss artist: 3 (50.0%)



1996

Total number of programs: 7

Exhibitions by contemporary artists: 5 (71.4%)

Exhibitions of the collection: 2 (28.6%)

Unkown category: 0 (0.0%)

Total number of participating artists in exhibitions: 13

International artist: 1 (7.7%)

Lokal artist: 2 (15.4%)

Swiss artist: 10 (76.9%)

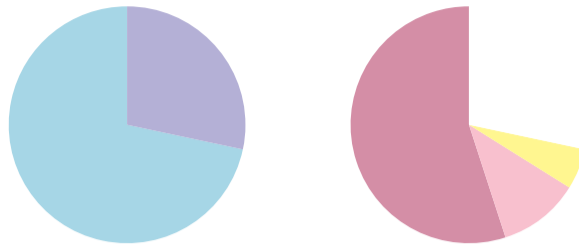

1997

Total number of programs: 9

Exhibitions by contemporary artists: 6 (66.7%)

Exhibitions of the collection: 2 (22.2%)

Unkown category: 1 (11.1%)

Total number of participating artists in exhibitions: 7

International artist: 1 (14.3%)

Lokal artist: 4 (57.1%)

Swiss artist: 2 (28.6%)

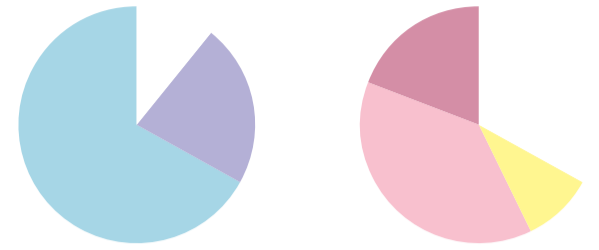

1998

Total number of programs: 11

Exhibitions by contemporary artists: 9 (81.8%)

Exhibitions of the collection: 0 (0.0%)

Unkown category: 2 (18.2%)

Total number of participating artists in exhibitions: 9

International artist: 3 (33.3%)

Lokal artist: 1 (11.1%)

Swiss artist: 5 (55.6%)



1999

Total number of programs: 13

Exhibitions by contemporary artists: 10 (76.9%)

Exhibitions of the collection: 1 (7.7%)

Unkown category: 2 (15.4%)

Total number of participating artists in exhibitions: 10

International artist: 4 (7.7%)

Lokal artist: 1 (15.4%)

Swiss artist: 5 (76.9%)

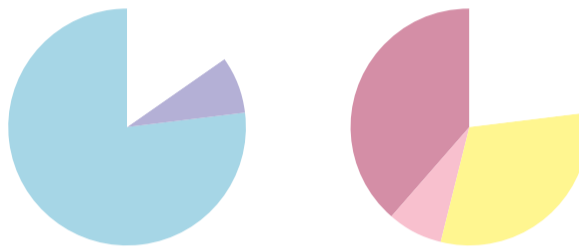

2000

Total number of programs: 11

Exhibitions by contemporary artists: 11 (100%)

Exhibitions of the collection: 0 (0.0%)

Unkown category: 0 (0.0%)

Total number of participating artists in exhibitions: 12

International artist: 7 (58.4%)

Lokal artist: 1 (8.3%)

Swiss artist: 4 (33.3%)

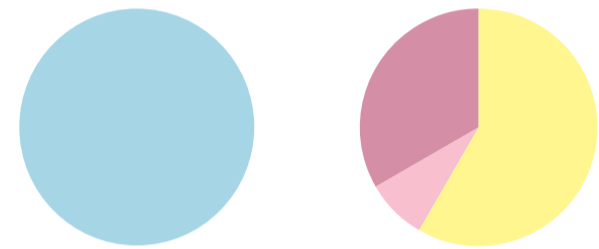

2001

Total number of programs: 11

Exhibitions by contemporary artists: 9 (81.8%)

Exhibitions of the collection: 2 (18.2%)

Unkown category: 0 (0.0%)

Total number of participating artists in exhibitions: 11

International artist: 6 (7.7%)

Lokal artist: 4 (15.4%)

Swiss artist: 1 (76.9%)

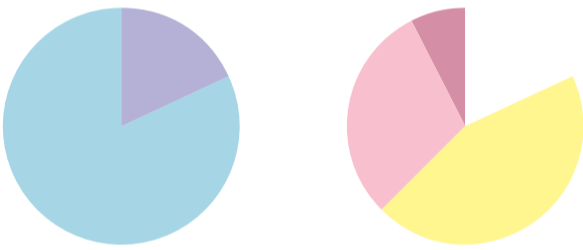

2002

Total number of programs: 8

Exhibitions by contemporary artists: 7 (87.5%)

Exhibitions of the collection: 1 (12.5%)

Unkown category: 0 (0.0%)

Total number of participating artists in exhibitions: 10

International artist: 4 (40.0%)

Lokal artist: 4 (40.0%)

Swiss artist: 2 (20.0%)

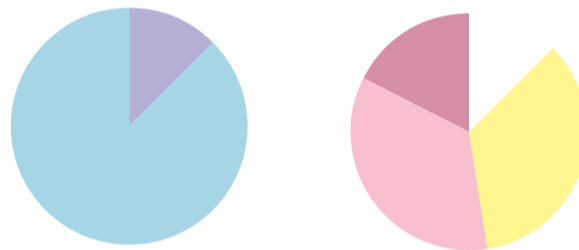

2003

Total number of programs: 13

Exhibitions by contemporary artists: 12 (92.3%)

Exhibitions of the collection: 1 (7.7%)

Unkown category: 0 (0.0%)

Total number of participating artists in exhibitions: 25

International artist: 10 (40.0%)

Lokal artist: 5 (20.0%)

Swiss artist: 10 (40.0%)

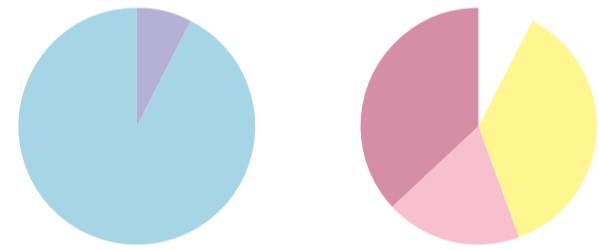

2004

Total number of programs: 11

Exhibitions by contemporary artists: 7 (63.6%)

Exhibitions of the collection: 2 (18.2%)

Unkown category: 2 (18.2%)

Total number of participating artists in exhibitions: 7

International artist: 1 (14.3%)

Lokal artist: 2 (28.6%)

Swiss artist: 4 (57.1%)

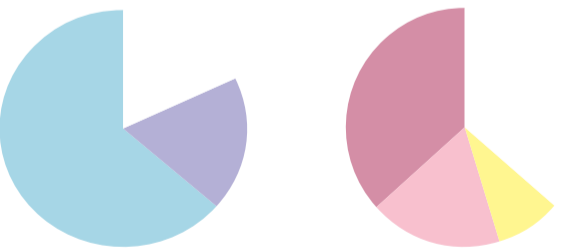

2005

Total number of programs: 11

Exhibitions by contemporary artists: 5 (45.5%)

Exhibitions of the collection: 5 (45.5%)

Unkown category: 1 (9.0%)

Total number of participating artists in exhibitions: 12

International artist: 7 (58.3%)

Lokal artist: 2 (16.7%)

Swiss artist: 3 (25.0%)

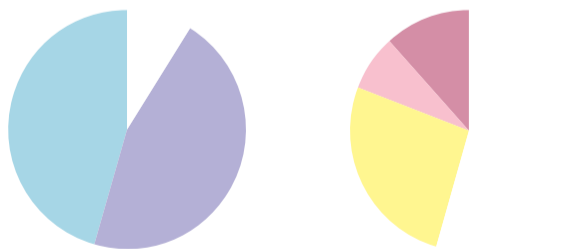

2006

Total number of programs: 13

Exhibitions by contemporary artists: 7 (53.8%)

Exhibitions of the collection: 4 (30.8%)

Unkown category: 2 (15.4%)

Total number of participating artists in exhibitions: 8

International artist: 4 (50.0%)

Lokal artist: 1 (12.5%)

Swiss artist: 3 (37.5%)



2007

Total number of programs: 10

Exhibitions by contemporary artists: 7 (70.0%)

Exhibitions of the collection: 2 (20.0%)

Unkown category: 1 (10.0%)

Total number of participating artists in exhibitions: 11

International artist: 6 (54.5%)

Lokal artist: 1 (9.1%)

Swiss artist: 4 (36.4%)

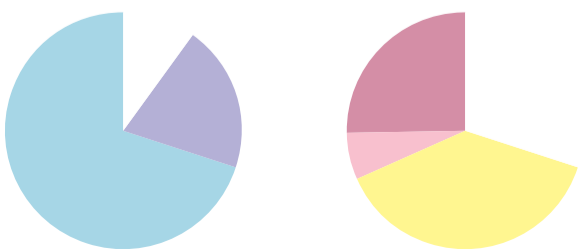

2008

Total number of programs: 6

Exhibitions by contemporary artists: 4 (66.7%)

Exhibitions of the collection: 2 (33.3%)

Unkown category: 0 (0.0%)

Total number of participating artists in exhibitions: 10

International artist: 7 (70.0%)

Lokal artist: 2 (20.0%)

Swiss artist: 1 (10.0%)



2009

Total number of programs: 8

Exhibitions by contemporary artists: 6 (75.0%)

Exhibitions of the collection: 1 (12.5%)

Unkown category: 1 (12.5%)

Total number of participating artists in exhibitions: 7

International artist: 3 (42.8%)

Lokal artist: 2 (28.6%)

Swiss artist: 2 (28.6%)

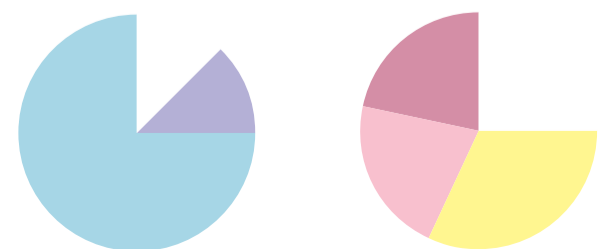

2010

Total number of programs: 8

Exhibitions by contemporary artists: 7 (87.5%)

Exhibitions of the collection: 1 (12.5%)

Unkown category: 0 (0.0%)

Total number of participating artists in exhibitions: 34

International artist: 15 (44.1%)

Lokal artist: 1 (3.0%)

Swiss artist: 18 (52.9%)

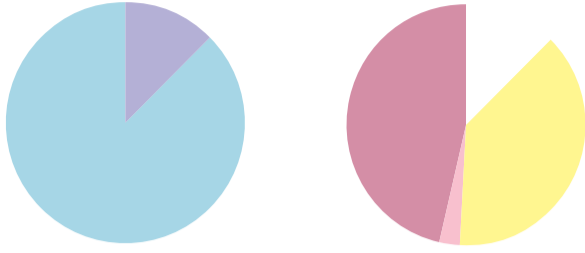

2011

Total number of programs: 8

Exhibitions by contemporary artists: 6 (75.0%)

Exhibitions of the collection: 2 (25.0%)

Unkown category: 0 (0.0%)

Total number of participating artists in exhibitions: 22

International artist: 10 (45.4%)

Lokal artist: 4 (18.2%)

Swiss artist: 8 (36.4%)

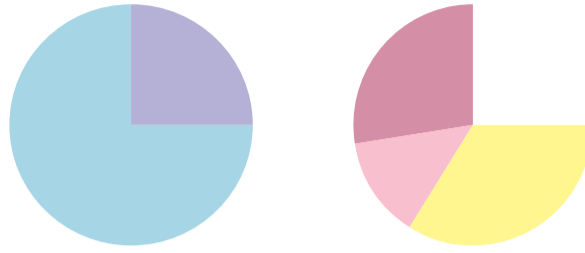

2012

Total number of programs: 8

Exhibitions by contemporary artists: 7 (87.5%)

Exhibitions of the collection: 1 (12.5%)

Unkown category: 0 (0.0%)

Total number of participating artists in exhibitions: 19

International artist: 8 (42.1%)

Lokal artist: 2 (10.5%)

Swiss artist: 9 (47.4%)

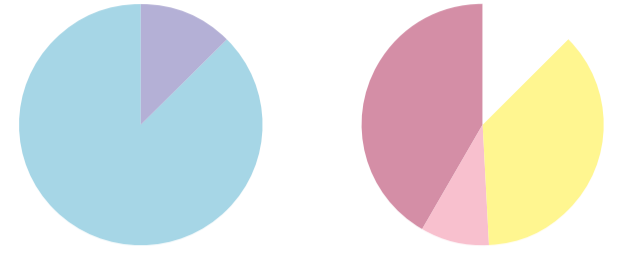

2013

Total number of programs: 8

Exhibitions by contemporary artists: 7 (87.5%)

Exhibitions of the collection: 1 (12.5%)

Unkown category: 0 (0.0%)

Total number of participating artists in exhibitions: 7

International artist: 4 (57.1%)

Lokal artist: 1 (14.3%)

Swiss artist: 2 (28.6%)

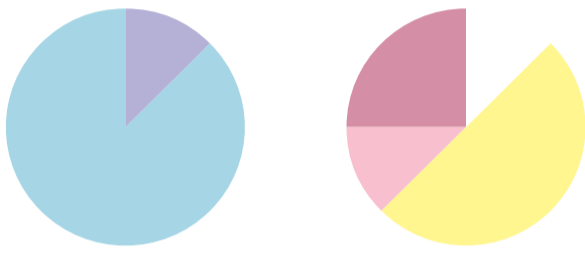

2014

Total number of programs: 8

Exhibitions by contemporary artists: 6 (75.0%)

Exhibitions of the collection: 1 (12.5%)

Unkown category: 1 (12.5%)

Total number of participating artists in exhibitions: 8

International artist: 3 (37.5%)

Lokal artist: 2 (25.0%)

Swiss artist: 3 (37.5%)

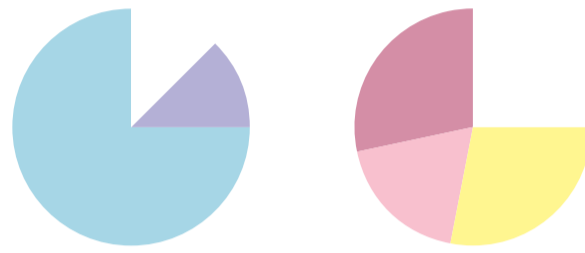

2015

Total number of programs: 6

Exhibitions by contemporary artists: 4 (66.6%)

Exhibitions of the collection: 1 (16.7%)

Unkown category: 1 (16.7%)

Total number of participating artists in exhibitions: 28

International artist: 13 (46.4%)

Lokal artist: 1 (3.6%)

Swiss artist: 14 (50.0%)



2016

Total number of programs: 7

Exhibitions by contemporary artists: 6 (85.7%)

Exhibitions of the collection: 1 (14.3%)

Unkown category: 0 (0.0%)

Total number of participating artists in exhibitions: 15

International artist: 8 (53.3%)

Lokal artist: 1 (6.7%)

Swiss artist: 6 (40.0%)

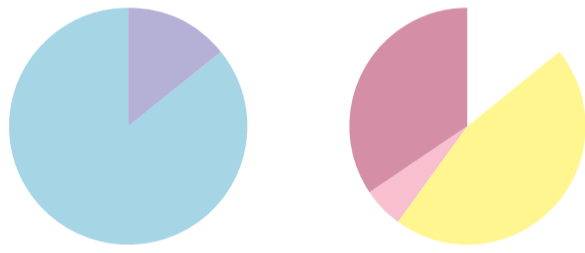

2017

Total number of programs: 10

Exhibitions by contemporary artists: 6 (50.0%)

Exhibitions of the collection: 1 (10.0%)

Unkown category: 4 (40.0%)

Total number of participating artists in exhibitions: 16

International artist: 8 (50.0%)

Lokal artist: 0 (0.0%)

Swiss artist: 8 (50.0%)



2018

Total number of programs: 4

Exhibitions by contemporary artists: 4 (100%)

Exhibitions of the collection: 0 (0.0%)

Unkown category: 0 (0.0%)

Total number of participating artists in exhibitions: 9

International artist: 5 (55.6%)

Lokal artist: 1 (11.1%)

Swiss artist: 3 (33.3%)

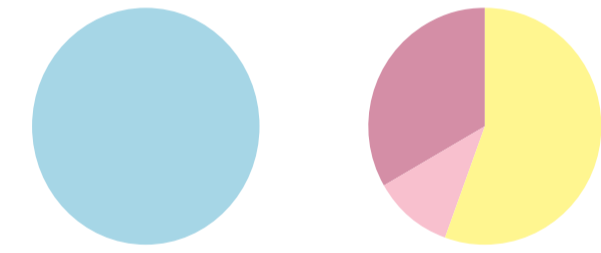

2019

Total number of programs: 4

Exhibitions by contemporary artists: 2 (50.0%)

Exhibitions of the collection: 1 (25.0%)

Unkown category: 1 (25.0%)

Total number of participating artists in exhibitions: 2

International artist: 2 (100.0%)

Lokal artist: 0 (0.0%)

Swiss artist: 0 (0.0%)



2020

Total number of programs: 7

Exhibitions by contemporary artists: 6 (71.4%)

Exhibitions of the collection: 1 (14.3%)

Unkown category: 1 (14.3%)

Total number of participating artists in exhibitions: 13

International artist: 6 (46.1%)

Lokal artist: 3 (23.1%)

Swiss artist: 4 (30.8%)

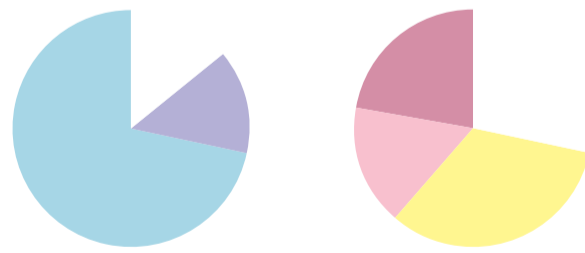

2021

Total number of programs: 6

Exhibitions by contemporary artists: 4 (66.6%)

Exhibitions of the collection: 0 (0.0%)

Unkown category: 2 (33.4%)

Total number of participating artists in exhibitions: 4

International artist: 3 (75.0%)

Lokal artist: 0 (0.0%)

Swiss artist: 1 (25.0%)



2022

Total number of programs: 9

Exhibitions by contemporary artists: 6 (66.7%)

Exhibitions of the collection: 2 (22.2%)

Unkown category: 1 (11.1%)

Total number of participating artists in exhibitions: 6

International artist: 5 (83.3%)

Lokal artist: 1 (16.7%)

Swiss artist: 0 (0.0%)

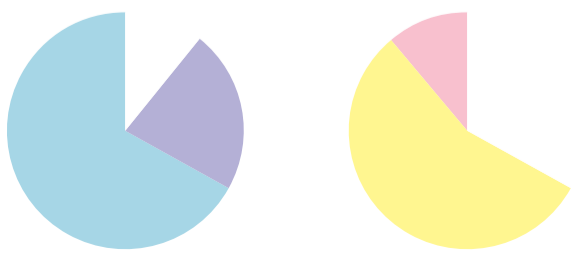

2023

Total number of programs: 6

Exhibitions by contemporary artists: 3 (50.0%)

Exhibitions of the collection: 3 (50.0%)

Unkown category: 0 (0.0%)

Total number of participating artists in exhibitions: 3

International artist: 2 (66.7%)

Lokal artist: 0 (0.0%)

Swiss artist: 1 (33.3%)

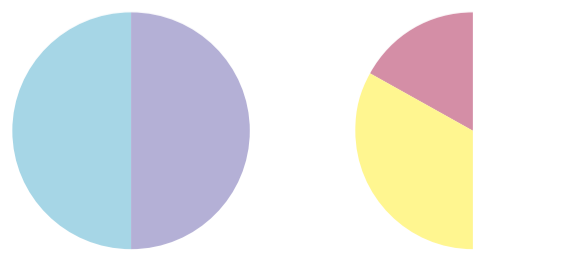

Average 1995 - 2023

Total number of programs: 10

Exhibitions by contemporary artists: 7 (70.0%)

Exhibitions of the collection: 2 (20.0%)

Unkown category: 1 (10.0%)

Total number of participating artists in exhibitions: 13

International artist: 6 (46.1%)

Lokal artist: 2 (15.4%)

Swiss artist: 5 (38.5%)

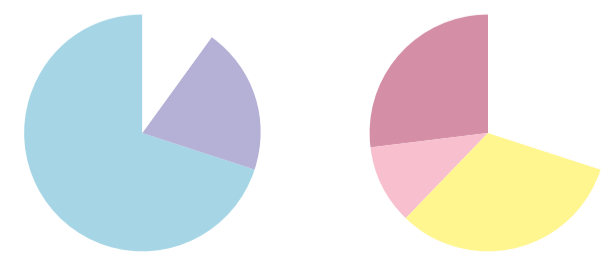

1995

Total number of programs: 9

Exhibitions by contemporary artists: 5 (55.6%)

Exhibitions of the collection: 3 (33.3%)

Unkown category: 1 (11.1%)

Total number of participating artists in exhibitions: 6

International artist: 1 (16.7%)

Lokal artist: 2 (33.3%)

Swiss artist: 3 (50.0%)



Programs

● ●
<meta itemprop="startDate" content="1995-12-03">
<meta itemprop="endDate" content="1996-01-14">
<p class="date">03.12.1995–14.01.1996</p>
<div class="artists">

<meta itemprop="startDate" content="1995-09-24">
<meta itemprop="endDate" content="1995-11-18">
<p class="date">24.09.–18.11.1995</p>
<div class="artists">

● ●
<meta itemprop="startDate" content="1995-07-02">
<meta itemprop="endDate" content="1995-09-10">
<p class="date">02.07.–10.09.1995</p>
Helen Chadwick

● ●
<meta itemprop="startDate" content="1995-06-29">
<meta itemprop="endDate" content="1995-09-10">
<p class="date">29.06.–10.09.1995</p>
Peter Britt

●
<meta itemprop="startDate" content="1995-04-14">
<meta itemprop="endDate" content="1995-06-18">
<p class="date">14.04.–18.06.1995</p>
<div class="artists">

● ●
<meta itemprop="startDate" content="1995-04-14">
<meta itemprop="endDate" content="1995-06-18">
<p class="date">14.04.–18.06.1995</p>
Simone Ch. Wicki

●
<meta itemprop="startDate" content="1995-04-14">
<meta itemprop="endDate" content="1995-06-18">
<p class="date">14.04.–18.06.1995</p>

● ●
<meta itemprop="startDate" content="1995-01-29">
<meta itemprop="endDate" content="1995-04-02">
<p class="date">29.01.–02.04.1995</p>

●
<meta itemprop="startDate" content="1995-01-29">
<meta itemprop="endDate" content="1995-04-02">
<p class="date">29.01.–02.04.1995</p>
<div class="artists">

1996

Total number of programs: 7

Exhibitions by contemporary artists: 5 (71.4%)

Exhibitions of the collection: 2 (28.6%)

Unkown category: 0 (0.0%)

Total number of participating artists in exhibitions: 13

International artist: 1 (7.7%)

Lokal artist: 2 (15.4%)

Swiss artist: 10 (76.9%)

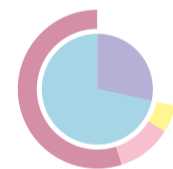

Programs

● ●
<meta itemprop="startDate" content="1996-12-01">
<meta itemprop="endDate" content="1997-01-12">
<p class="date">01.12.1996–12.01.1997</p>
<div class="artists">

● ●
<meta itemprop="startDate" content="1996-09-15">
<meta itemprop="endDate" content="1996-11-17">
<p class="date">15.09.–17.11.1996</p>
<div class="artists">

● ●
<meta itemprop="startDate" content="1996-09-15">
<meta itemprop="endDate" content="1996-11-17">
<p class="date">15.09.–17.11.1996</p>

●
<meta itemprop="startDate" content="1996-06-23">
<meta itemprop="endDate" content="1996-09-01">
<p class="date">23.06.–01.09.1996</p>
<div class="artists">

● ●
<meta itemprop="startDate" content="1996-06-23">
<meta itemprop="endDate" content="1996-09-01">
<p class="date">23.06.–01.09.1996</p>
<div class="artists">

●
<meta itemprop="startDate" content="1996-04-05">
<meta itemprop="endDate" content="1996-06-09">
<p class="date">05.04.–09.06.1996</p>
<div class="artists">

● ●
<meta itemprop="startDate" content="1996-01-28">
<meta itemprop="endDate" content="1996-03-24">
<p class="date">28.01.–24.03.1996</p>
<h2>Gastausstellung Prof. Peter Jenny, ETH Zürich - Bauhaus Dessau</h2>

1997

Total number of programs: 9

Exhibitions by contemporary artists: 6 (66.7%)

Exhibitions of the collection: 2 (22.2%)

Unkown category: 1 (11.1%)

Total number of participating artists in exhibitions: 7

International artist: 1 (14.3%)

Lokal artist: 4 (57.1%)

Swiss artist: 2 (28.6%)



Programs

• •
<meta itemprop="startDate" content="1997-11-30">
<meta itemprop="endDate" content="1998-01-11">
<p class="date">30.11.1997–11.01.1998</p>
<div class="artists">

• •
<meta itemprop="startDate" content="1997-09-14">
<meta itemprop="endDate" content="1997-11-16">
<p class="date">14.09.–16.11.1997</p>

• •
<meta itemprop="startDate" content="1997-09-14">
<meta itemprop="endDate" content="1997-11-16">
<p class="date">14.09.–16.11.1997</p>
Jakob Wäch

•
<meta itemprop="startDate" content="1997-09-14">
<meta itemprop="endDate" content="1997-11-16">
<p class="date">14.09.–16.11.1997</p>

<meta itemprop="startDate" content="1997-07-01">
<meta itemprop="endDate" content="1997-08-31">
<p class="date">01.07.–31.08.1997</p>

• •
<meta itemprop="startDate" content="1997-06-29">
<meta itemprop="endDate" content="1997-08-31">
<p class="date">29.06.–31.08.1997</p>
<div class="artists">

• •
<meta itemprop="startDate" content="1997-05-04">
<meta itemprop="endDate" content="1997-06-15">
<p class="date">04.05.–15.06.1997</p>

• •
<meta itemprop="startDate" content="1997-04-17">
<meta itemprop="endDate" content="1997-06-15">
<p class="date">17.04.–15.06.1997</p>

•
<meta itemprop="startDate" content="1997-01-26">
<meta itemprop="endDate" content="1997-04-20">
<p class="date">26.01.–20.04.1997</p>
<div class="artists">

1998

Total number of programs: 11

Exhibitions by contemporary artists: 9 (81.8%)

Exhibitions of the collection: 0 (0.0%)

Unkown category: 2 (18.2%)

Total number of participating artists in exhibitions: 9

International artist: 3 (33.3%)

Lokal artist: 1 (11.1%)

Swiss artist: 5 (55.6%)



Programs

• •
<meta itemprop="startDate" content="1998-12-05">
<meta itemprop="endDate" content="1999-01-10">
<p class="date">05.12.1998–10.01.1999</p>
<div class="artists">

• •
<meta itemprop="startDate" content="1998-12-05">
<meta itemprop="endDate" content="1999-01-10">
<p class="date">05.12.1998–10.01.1999</p>
Patrick Rohner

• •
<meta itemprop="startDate" content="1998-09-26">
<meta itemprop="endDate" content="1998-11-22">
<p class="date">26.09.–22.11.1998</p>

• •
<meta itemprop="startDate" content="1998-07-31">
<meta itemprop="endDate" content="1998-09-13">
<p class="date">31.07.–13.09.1998</p>
Roland Herzog

• •
<meta itemprop="startDate" content="1998-07-31">
<meta itemprop="endDate" content="1998-09-13">
<p class="date">31.07.–13.09.1998</p>

<meta itemprop="startDate" content="1998-06-28">
<meta itemprop="endDate" content="1998-08-30">
<p class="date">28.06.–30.08.1998</p>

<meta itemprop="startDate" content="1998-06-28">
<meta itemprop="endDate" content="1998-08-30">
<p class="date">28.06.–30.08.1998</p>

• •
<meta itemprop="startDate" content="1998-05-16">
<meta itemprop="endDate" content="1998-07-19">
<p class="date">16.05.–19.07.1998</p>
Joseph Kosuth

● ●
<meta itemprop="startDate" content="1998-04-18">
<meta itemprop="endDate" content="1998-06-14">
<p class="date">18.04.–14.06.1998</p>
Olaf Breuning

● ●
<meta itemprop="startDate" content="1998-02-28">
<meta itemprop="endDate" content="1998-05-03">
<p class="date">28.02.–03.05.1998</p>

● ●
<meta itemprop="startDate" content="1998-01-24">
<meta itemprop="endDate" content="1998-04-13">
<p class="date">24.01.–13.04.1998</p>

1999

Total number of programs: 13

Exhibitions by contemporary artists: 10 (76.9%)

Exhibitions of the collection: 1 (7.7%)

Unkown category: 2 (15.4%)

Total number of participating artists in exhibitions: 10

International artist: 4 (7.7%)

Lokal artist: 1 (15.4%)

Swiss artist: 5 (76.9%)



Programs

● ●
<meta itemprop="startDate" content="1999-12-04">
<meta itemprop="endDate" content="2000-01-09">
<p class="date">04.12.1999–09.01.2000</p>
<div class="artists">

● ●
<meta itemprop="startDate" content="1999-12-04">
<meta itemprop="endDate" content="2000-01-09">
<p class="date">04.12.1999–09.01.2000</p>
Nicole Böniger

● ●
<meta itemprop="startDate" content="1999-09-10">
<meta itemprop="endDate" content="1999-11-21">
<p class="date">10.09.–21.11.1999</p>
Ugo Rondinone

● ●
<meta itemprop="startDate" content="1999-09-10">
<meta itemprop="endDate" content="1999-11-21">
<p class="date">10.09.–21.11.1999</p>

● ●
<meta itemprop="startDate" content="1999-06-27">
<meta itemprop="endDate" content="1999-08-29">
<p class="date">27.06.–29.08.1999</p>
Roman Kurzmeier

● ●
<meta itemprop="startDate" content="1999-06-27">
<meta itemprop="endDate" content="1999-08-29">
<p class="date">27.06.–29.08.1999</p>

● ●
<meta itemprop="startDate" content="1999-05-16">
<meta itemprop="endDate" content="1999-06-13">
<p class="date">16.05.–13.06.1999</p>
Suzy Spence

● ●
<meta itemprop="startDate" content="1999-04-10">
<meta itemprop="endDate" content="1999-06-13">
<p class="date">10.04.–13.06.1999</p>

<meta itemprop="startDate" content="1999-03-05">
<meta itemprop="endDate" content="1999-03-07">
<p class="date">05.03.–07.03.1999</p>
<div class="artists">

● ●
<meta itemprop="startDate" content="1999-01-30">
<meta itemprop="endDate" content="1999-03-28">
<p class="date">30.01.–28.03.1999</p>
Emmanuelle Antille

● ●
<meta itemprop="startDate" content="1999-01-30">
<meta itemprop="endDate" content="1999-02-28">
<p class="date">30.01.–28.02.1999</p>
Kristin Lucas

<meta itemprop="startDate" content="1999-01-30">
<meta itemprop="endDate" content="1999-03-28">
<p class="date">30.01.–28.03.1999</p>

●
<meta itemprop="startDate" content="1999-01-24">
<meta itemprop="endDate" content="1999-03-28">
<p class="date">24.01.–28.03.1999</p>

2000

Total number of programs: 11

Exhibitions by contemporary artists: 11 (100%)

Exhibitions of the collection: 0 (0.0%)

Unkown category: 0 (0.0%)

Total number of participating artists in exhibitions: 12

International artist: 7 (58.4%)

Lokal artist: 1 (8.3%)

Swiss artist: 4 (33.3%)

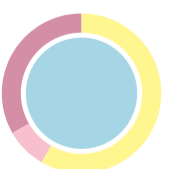

Programs

- [Kunstschaffen Glarus und Linthgebiet R-Z](#)
<meta itemprop="startDate" content="2000-12-02">
<meta itemprop="endDate" content="2001-01-07">
<p class="date">02.12.2000–07.01.2001</p>
<div class="artists">
- [Fokus-Preis 2000](#)
<meta itemprop="startDate" content="2000-12-02">
<meta itemprop="endDate" content="2001-01-07">
<p class="date">02.12.2000–07.01.2001</p>
Peter Kamm
- [Peter Land](#)
<meta itemprop="startDate" content="2000-09-09">
<meta itemprop="endDate" content="2000-11-19">
<p class="date">09.09.–19.11.2000</p>
- [De Rijke de Rooij](#)
<meta itemprop="startDate" content="2000-09-09">
<meta itemprop="endDate" content="2000-11-19">
<p class="date">09.09.–19.11.2000</p>
- [bad bed bud pad bet pub](#)
<meta itemprop="startDate" content="2000-06-24">
<meta itemprop="endDate" content="2000-08-27">
<p class="date">24.06.–27.08.2000</p>
Monica Bonvicini
- [Das linke Bein des Offiziers](#)
<meta itemprop="startDate" content="2000-06-24">
<meta itemprop="endDate" content="2000-08-27">
<p class="date">24.06.–27.08.2000</p>
Daniel Roth
- [Tagessuppen / Domestic Pairs Project \(mit Keith Tyson\)](#)
<meta itemprop="startDate" content="2000-04-01">
<meta itemprop="endDate" content="2000-06-12">
<p class="date">01.04.–12.06.2000</p>
Urs Fischer
- [Die pädagogische Wunderkammer ... Raritätenkabinett ... Schulmeisters](#)
<meta itemprop="startDate" content="2000-04-01">
<meta itemprop="endDate" content="2000-06-12">
<p class="date">01.04.–12.06.2000</p>
Peter Jenny
- [Alfred Leuzinger](#)
<meta itemprop="startDate" content="2000-01-22">
<meta itemprop="endDate" content="2000-03-19">
<p class="date">22.01.–19.03.2000</p>
- [Muntean Rosenblum](#)
<meta itemprop="startDate" content="2000-01-22">
<meta itemprop="endDate" content="2000-03-19">
<p class="date">22.01.–19.03.2000</p>
- [T.J. Wilcox](#)
<meta itemprop="startDate" content="2000-01-22">
<meta itemprop="endDate" content="2000-03-19">
<p class="date">22.01.–19.03.2000</p>

[2001](/de/ausstellungen/archiv/year/2001)

Total number of programs: 11

Exhibitions by contemporary artists: 9 (81.8%)
Exhibitions of the collection: 2 (18.2%)
Unkown category: 0 (0.0%)

Total number of participating artists in exhibitions: 11

International artist: 6 (7.7%)
Lokal artist: 4 (15.4%)
Swiss artist: 1 (76.9%)

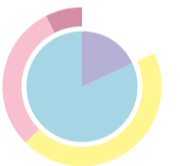

Programs

- [Kunstschaffen Glarus und Linthgebiet A-H 2001](#)
<meta itemprop="startDate" content="2001-12-01">
<meta itemprop="endDate" content="2002-01-05">
<p class="date">01.12.2001–05.01.2002</p>
<div class="artists">
- [Fokus-Preis 2001](#)
<meta itemprop="startDate" content="2001-12-01">
<meta itemprop="endDate" content="2002-01-06">
<p class="date">01.12.2001–06.01.2002</p>
Peter Kamm
- [Eile mit Weile oder langer Weg zur schönen Geschichte](#)
<meta itemprop="startDate" content="2001-12-01">
<meta itemprop="endDate" content="2002-01-06">
<p class="date">01.12.2001–06.01.2002</p>
Vre Tschudi
- [Z Point](#)
<meta itemprop="startDate" content="2001-09-08">
<meta itemprop="endDate" content="2001-11-18">
<p class="date">08.09.–18.11.2001</p>
Angela Bulloch
- [Cerith Wyn Evans](#)
<meta itemprop="startDate" content="2001-06-23">
<meta itemprop="endDate" content="2001-11-18">
<p class="date">23.06.–18.11.2001</p>
- [Liaisons - Collections](#)
<meta itemprop="startDate" content="2001-06-23">
<meta itemprop="endDate" content="2001-11-18">
<p class="date">23.06.–18.11.2001</p>
<div class="artists">
- [Fischbau Ingrid Käser und Katrin Hotz](#)
<meta itemprop="startDate" content="2001-04-07">
<meta itemprop="endDate" content="2001-06-10">
<p class="date">07.04.–10.06.2001</p>
- [Knut Asdam](#)
<meta itemprop="startDate" content="2001-04-07">
<meta itemprop="endDate" content="2001-06-10">
<p class="date">07.04.–10.06.2001</p>
- [Paul Pfeiffer](#)
<meta itemprop="startDate" content="2001-04-07">
<meta itemprop="endDate" content="2001-06-10">
<p class="date">07.04.–10.06.2001</p>
- [A Huge Ever Growing Pulsating Brain That Rules ... \(the Orb, 1991\)](#)
<meta itemprop="startDate" content="2001-01-27">
<meta itemprop="endDate" content="2001-03-25">
<p class="date">27.01.–25.03.2001</p>
<div class="artists">

●
<meta itemprop="startDate" content="2001-01-27">
<meta itemprop="endDate" content="2001-03-25">
<p class="date">27.01.–25.03.2001</p>
Lill Tschudi

2002

Total number of programs: 8

Exhibitions by contemporary artists: 7 (87.5%)

Exhibitions of the collection: 1 (12.5%)

Unkown category: 0 (0.0%)

Total number of participating artists in exhibitions: 10

International artist: 4 (40.0%)

Lokal artist: 4 (40.0%)

Swiss artist: 2 (20.0%)

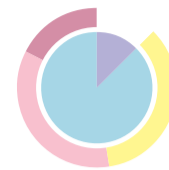

Programs

● ●
<meta itemprop="startDate" content="2002-12-01">
<meta itemprop="endDate" content="2003-01-05">
<p class="date">01.12.2002–05.01.2003</p>
<div class="artists">

● ●
<meta itemprop="startDate" content="2002-12-01">
<meta itemprop="endDate" content="2003-01-05">
<p class="date">01.12.2002–05.01.2003</p>
Tina Hauser

● ●
<meta itemprop="startDate" content="2002-10-17">
<meta itemprop="endDate" content="2003-04-22">
<p class="date">17.10.2002–22.04.2003</p>
Fischbau: Katrin Hotz & Ingrid Käser

● ●
<meta itemprop="startDate" content="2002-07-07">
<meta itemprop="endDate" content="2002-09-01">
<p class="date">07.07.–01.09.2002</p>
<div class="artists">

● ●
<meta itemprop="startDate" content="2002-04-21">
<meta itemprop="endDate" content="2002-06-23">
<p class="date">21.04.–23.06.2002</p>
Graeme Todd

●
<meta itemprop="startDate" content="2002-04-21">
<meta itemprop="endDate" content="2002-06-23">
<p class="date">21.04.–23.06.2002</p>
Hans Conrad Escher Von Der Linth

●
<meta itemprop="startDate" content="2002-04-21">
<meta itemprop="endDate" content="2002-06-23">
<p class="date">21.04.–23.06.2002</p>

● ●
<meta itemprop="startDate" content="2002-01-27">
<meta itemprop="endDate" content="2002-04-01">
<p class="date">27.01.–01.04.2002</p>
Gillian Wearing

2003

Total number of programs: 13

Exhibitions by contemporary artists: 12 (92.3%)

Exhibitions of the collection: 1 (7.7%)

Unkown category: 0 (0.0%)

Total number of participating artists in exhibitions: 25

International artist: 10 (40.0%)

Lokal artist: 5 (20.0%)

Swiss artist: 10 (40.0%)

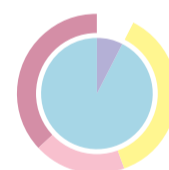

Programs

● ●
<meta itemprop="startDate" content="2003-11-29">
<meta itemprop="endDate" content="2004-01-11">
<p class="date">29.11.2003–11.01.2004</p>
<div class="artists">

● ●
<meta itemprop="startDate" content="2003-11-29">
<meta itemprop="endDate" content="2004-01-11">
<p class="date">29.11.2003–11.01.2004</p>
Rahel Opprecht

● ●
<meta itemprop="startDate" content="2003-11-04">
<meta itemprop="endDate" content="2004-04-30">
<p class="date">04.11.2003–30.04.2004</p>
Ruth Blesi

● ●
<meta itemprop="startDate" content="2003-09-14">
<meta itemprop="endDate" content="2003-11-16">
<p class="date">14.09.–16.11.2003</p>
Julika Rudelius

● ●
<meta itemprop="startDate" content="2003-09-14">
<meta itemprop="endDate" content="2003-11-16">
<p class="date">14.09.–16.11.2003</p>
Carl Andre

● ●
<meta itemprop="startDate" content="2003-09-14">
<meta itemprop="endDate" content="2003-11-16">
<p class="date">14.09.–16.11.2003</p>
Manuel Stagers

● ●
<meta itemprop="startDate" content="2003-06-29">
<meta itemprop="endDate" content="2003-08-24">
<p class="date">29.06.–24.08.2003</p>
<div class="artists">

● ●
<meta itemprop="startDate" content="2003-06-29">
<meta itemprop="endDate" content="2003-08-24">
<p class="date">29.06.–24.08.2003</p>

● ●
<meta itemprop="startDate" content="2003-04-18">
<meta itemprop="endDate" content="2003-06-05">
<p class="date">18.04.–05.06.2003</p>
Hanspeter Hofmann

● ●
<meta itemprop="startDate" content="2003-04-18">
<meta itemprop="endDate" content="2003-06-15">
<p class="date">18.04.–15.06.2003</p>
Tom O'Connell & Joanne Tatham

● ●
<meta itemprop="startDate" content="2003-04-18">
<meta itemprop="endDate" content="2003-06-15">
<p class="date">18.04.–15.06.2003</p>
Frédéric Post

●
<meta itemprop="startDate" content="2003-01-26">
<meta itemprop="endDate" content="2003-03-30">
<p class="date">26.01.–30.03.2003</p>
Gustav Schneeli

● ●
<meta itemprop="startDate" content="2003-01-26">
<meta itemprop="endDate" content="2003-03-30">
<p class="date">26.01.–30.03.2003</p>
<div class="artists">

2004

Total number of programs: 11

Exhibitions by contemporary artists: 7 (63.6%)

Exhibitions of the collection: 2 (18.2%)

Unkown category: 2 (18.2%)

Total number of participating artists in exhibitions: 7

International artist: 1 (14.3%)

Lokal artist: 2 (28.6%)

Swiss artist: 4 (57.1%)



Programs

● ●
<meta itemprop="startDate" content="2004-12-07">
<meta itemprop="endDate" content="2005-01-16">
<p class="date">07.12.2004–16.01.2005</p>
<div class="artists">

● ●
<meta itemprop="startDate" content="2004-12-07">
<meta itemprop="endDate" content="2005-01-16">
<p class="date">07.12.2004–16.01.2005</p>
Daniela Zimmermann

<meta itemprop="startDate" content="2004-10-30">
<meta itemprop="endDate" content="2004-10-21">
<p class="date">30.10.–21.10.2004</p>

● ●
<meta itemprop="startDate" content="2004-08-22">
<meta itemprop="endDate" content="2004-11-14">
<p class="date">22.08.–14.11.2004</p>
Daniel Robert Hunziker

●
<meta itemprop="startDate" content="2004-08-22">
<meta itemprop="endDate" content="2004-11-14">
<p class="date">22.08.–14.11.2004</p>

<meta itemprop="startDate" content="2004-06-15">
<meta itemprop="endDate" content="2004-06-20">
<p class="date">15.06.–20.06.2004</p>
<div class="artists">

● ●
<meta itemprop="startDate" content="2004-05-16">
<meta itemprop="endDate" content="2004-08-01">
<p class="date">16.05.–01.08.2004</p>
<div class="artists">

● ●
<meta itemprop="startDate" content="2004-05-16">
<meta itemprop="endDate" content="2004-08-01">
<p class="date">16.05.–01.08.2004</p>
Bettina Graf

●
<meta itemprop="startDate" content="2004-05-16">
<meta itemprop="endDate" content="2004-08-01">
<p class="date">16.05.–01.08.2004</p>
Lill Tschudi

●
<meta itemprop="startDate" content="2004-05-16">
<meta itemprop="endDate" content="2004-08-01">
<p class="date">16.05.–01.08.2004</p>

● ●
<meta itemprop="startDate" content="2004-02-01">
<meta itemprop="endDate" content="2004-05-02">
<p class="date">01.02.–02.05.2004</p>
Jim Shaw

2005

Total number of programs: 11

Exhibitions by contemporary artists: 5 (45.5%)

Exhibitions of the collection: 5 (45.5%)

Unkown category: 1 (9.0%)

Total number of participating artists in exhibitions: 12

International artist: 7 (58.3%)

Lokal artist: 2 (16.7%)

Swiss artist: 3 (25.0%)



Programs

- [Kunstschaffen Glarus und Linthgebiet I-Q 2005](#)
<meta itemprop="startDate" content="2005-12-04">
<meta itemprop="endDate" content="2006-01-15">
<p class="date">04.12.2005–15.01.2006</p>
<div class="artists">
- [Fokus-Preis 2005](#)
<meta itemprop="startDate" content="2005-12-04">
<meta itemprop="endDate" content="2006-01-15">
<p class="date">04.12.2005–15.01.2006</p>
Susanne Hauser
- [Nondeleted 2 - die nicht gelöschten Bilder „>](#)
<meta itemprop="startDate" content="2005-10-28">
<meta itemprop="endDate" content="2005-10-29">
<p class="date">28.10.–29.10.2005</p>
- [Lieblingsbilder aus der Sammlung: Eine Auswahl von Dahler](#)
<meta itemprop="startDate" content="2005-10-19">
<meta itemprop="endDate" content="2005-11-20">
<p class="date">19.10.–20.11.2005</p>
- [Lieblingsbilder aus der Sammlung: Eine Auswahl von Rast-Eicher](#)
<meta itemprop="startDate" content="2005-09-11">
<meta itemprop="endDate" content="2005-10-16">
<p class="date">11.09.–16.10.2005</p>
- [Recreating the Case](#)
<meta itemprop="startDate" content="2005-09-11">
<meta itemprop="endDate" content="2005-11-20">
<p class="date">11.09.–20.11.2005</p>
<div class="artists">
- [Lieblingsbilder aus der Sammlung: Eine Auswahl von Vito Giorgio](#)
<meta itemprop="startDate" content="2005-07-06">
<meta itemprop="endDate" content="2005-08-21">
<p class="date">06.07.–21.08.2005</p>
- [Lieblingsbilder aus der Sammlung: Eine Auswahl von Kesselring](#)
<meta itemprop="startDate" content="2005-05-22">
<meta itemprop="endDate" content="2005-07-03">
<p class="date">22.05.–03.07.2005</p>
- [Mirage of Loose Change](#)
<meta itemprop="startDate" content="2005-05-22">
<meta itemprop="endDate" content="2005-08-21">
<p class="date">22.05.–21.08.2005</p>
Gary Webb
- [Loin loin loin](#)
<meta itemprop="startDate" content="2005-02-05">
<meta itemprop="endDate" content="2005-05-01">
<p class="date">05.02.–01.05.2005</p>
Annelise Coste
- [Tausend und ein Blatt. Werke aus der Grafischen Sammlung...](#)
<meta itemprop="startDate" content="2005-02-05">
<meta itemprop="endDate" content="2005-05-01">
<p class="date">05.02.–01.05.2005</p>

[2006](/de/ausstellungen/archiv/year/2006)

Total number of programs: 13

Exhibitions by contemporary artists: 7 (53.8%)

Exhibitions of the collection: 4 (30.8%)

Unkown category: 2 (15.4%)

Total number of participating artists in exhibitions: 8

International artist: 4 (50.0%)

Lokal artist: 1 (12.5%)

Swiss artist: 3 (37.5%)



Programs

- [Kunstschaffen Glarus und Linthgebiet R-Z 2006](#)
<meta itemprop="startDate" content="2006-12-03">
<meta itemprop="endDate" content="2007-01-14">
<p class="date">03.12.2006–14.01.2007</p>
<div class="artists">
- [Fokus-Preis 2006](#)
<meta itemprop="startDate" content="2006-12-03">
<meta itemprop="endDate" content="2007-01-14">
<p class="date">03.12.2006–14.01.2007</p>
Matthias Käser
- [Value Inventar #1](#)
<meta itemprop="startDate" content="2006-11-01">
<meta itemprop="endDate" content="2006-11-19">
<p class="date">01.11.–19.11.2006</p>
- [Nondeleted 3 - die nicht gelöschten Bilder](#)
<meta itemprop="startDate" content="2006-10-27">
<meta itemprop="endDate" content="2006-10-28">
<p class="date">27.10.–28.10.2006</p>
- [Home Made - Do-It-Yourself Soundelectronics](#)
<meta itemprop="startDate" content="2006-10-25">
<meta itemprop="endDate" content="2006-10-29">
<p class="date">25.10.–29.10.2006</p>
- [Some Sin for Nothing](#)
<meta itemprop="startDate" content="2006-09-03">
<meta itemprop="endDate" content="2006-11-19">
<p class="date">03.09.–19.11.2006</p>
Tobias Zielony
- [Quelquepart II](#)
<meta itemprop="startDate" content="2006-09-03">
<meta itemprop="endDate" content="2006-09-19">
<p class="date">03.09.–19.09.2006</p>
<div class="artists">
- [Lieblingsbilder aus der Sammlung: Eine Auswahl von Baumgartner](#)
<meta itemprop="startDate" content="2006-09-03">
<meta itemprop="endDate" content="2006-10-22">
<p class="date">03.09.–22.10.2006</p>
- [Most und Karfunkel](#)
<meta itemprop="startDate" content="2006-05-28">
<meta itemprop="endDate" content="2006-08-13">
<p class="date">28.05.–13.08.2006</p>
Rolf Graf
- [Oben halb offen](#)
<meta itemprop="startDate" content="2006-05-28">
<meta itemprop="endDate" content="2006-08-13">
<p class="date">28.05.–13.08.2006</p>
Vaclav Pozarek

●
<meta itemprop="startDate" content="2006-05-28">
<meta itemprop="endDate" content="2006-08-13">
<p class="date">28.05.–13.08.2006</p>

● ●
<meta itemprop="startDate" content="2006-02-05">
<meta itemprop="endDate" content="2006-05-07">
<p class="date">05.02.–07.05.2006</p>
Markus Müller

●
<meta itemprop="startDate" content="2006-02-05">
<meta itemprop="endDate" content="2006-05-07">
<p class="date">05.02.–07.05.2006</p>

2007

Total number of programs: 10

Exhibitions by contemporary artists: 7 (70.0%)

Exhibitions of the collection: 2 (20.0%)

Unkown category: 1 (10.0%)

Total number of participating artists in exhibitions: 11

International artist: 6 (54.5%)

Lokal artist: 1 (9.1%)

Swiss artist: 4 (36.4%)



Programs

● ●
<meta itemprop="startDate" content="2007-12-02">
<meta itemprop="endDate" content="2008-01-13">
<p class="date">02.12.2007–13.01.2008</p>
<div class="artists">

● ●
<meta itemprop="startDate" content="2007-09-09">
<meta itemprop="endDate" content="2007-11-18">
<p class="date">09.09.–18.11.2007</p>
Peter Piller

●
<meta itemprop="startDate" content="2007-09-09">
<meta itemprop="endDate" content="2007-11-18">
<p class="date">09.09.–18.11.2007</p>
Jakob Ruch

● ●
<meta itemprop="startDate" content="2007-05-27">
<meta itemprop="endDate" content="2007-08-19">
<p class="date">27.05.–19.08.2007</p>
<div class="artists">

● ●
<meta itemprop="startDate" content="2007-05-27">
<meta itemprop="endDate" content="2007-08-19">
<p class="date">27.05.–19.08.2007</p>
Jeanne Faust

<meta itemprop="startDate" content="2007-05-27">
<meta itemprop="endDate" content="2007-08-19">
<p class="date">27.05.–19.08.2007</p>

● ●
<meta itemprop="startDate" content="2007-02-04">
<meta itemprop="endDate" content="2007-05-06">
<p class="date">04.02.–06.05.2007</p>
<div class="artists">

● ●
<meta itemprop="startDate" content="2007-02-04">
<meta itemprop="endDate" content="2007-05-06">
<p class="date">04.02.–06.05.2007</p>
<div class="artists">

●
<meta itemprop="startDate" content="2007-02-04">
<meta itemprop="endDate" content="2007-05-06">
<p class="date">04.02.–06.05.2007</p>

● ●
<meta itemprop="startDate" content="2007-02-04">
<meta itemprop="endDate" content="2007-04-15">
<p class="date">04.02.–15.04.2007</p>
David Thorpe

2008

Total number of programs: 6

Exhibitions by contemporary artists: 4 (66.7%)

Exhibitions of the collection: 2 (33.3%)

Unkown category: 0 (0.0%)

Total number of participating artists in exhibitions: 10

International artist: 7 (70.0%)

Lokal artist: 2 (20.0%)

Swiss artist: 1 (10.0%)

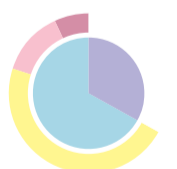

Programs

● ●
<meta itemprop="startDate" content="2008-12-07">
<meta itemprop="endDate" content="2009-01-25">
<p class="date">07.12.2008–25.01.2009</p>
<div class="artists">

● ●
<meta itemprop="startDate" content="2008-12-07">
<meta itemprop="endDate" content="2009-01-25">
<p class="date">07.12.2008–25.01.2009</p>
Irene Schubiger

●
<meta itemprop="startDate" content="2008-09-21">
<meta itemprop="endDate" content="2008-11-23">
<p class="date">21.09.–23.11.2008</p>

● ●
<meta itemprop="startDate" content="2008-06-21">
<meta itemprop="endDate" content="2008-09-07">
<p class="date">21.06.–07.09.2008</p>
<div class="artists">

● ●
<meta itemprop="startDate" content="2008-03-02">
<meta itemprop="endDate" content="2008-06-01">
<p class="date">02.03.–01.06.2008</p>
Raphael Hefti

●
<meta itemprop="startDate" content="2008-03-02">
<meta itemprop="endDate" content="2008-06-01">
<p class="date">02.03.–01.06.2008</p>
Urs Lüthi

2009

Total number of programs: 8

Exhibitions by contemporary artists: 6 (75.0%)

Exhibitions of the collection: 1 (12.5%)

Unkown category: 1 (12.5%)

Total number of participating artists in exhibitions: 7

International artist: 3 (42.8%)

Lokal artist: 2 (28.6%)

Swiss artist: 2 (28.6%)



Programs

● ●
<meta itemprop="startDate" content="2009-12-06">
<meta itemprop="endDate" content="2010-01-17">
<p class="date">06.12.2009–17.01.2010</p>
Katrin Hotz

● ●
<meta itemprop="startDate" content="2009-05-17">
<meta itemprop="endDate" content="2009-08-16">
<p class="date">17.05.–16.08.2009</p>
Kilian Rütthemann

● ●
<meta itemprop="startDate" content="2009-12-06">
<meta itemprop="endDate" content="2010-01-17">
<p class="date">06.12.2009–17.01.2010</p>
<div class="artists">

<meta itemprop="startDate" content="2009-03-07">
<meta itemprop="endDate" content="2009-03-26">
<p class="date">07.03.–26.03.2009</p>

● ●
<meta itemprop="startDate" content="2009-09-06">
<meta itemprop="endDate" content="2009-11-22">
<p class="date">06.09.–22.11.2009</p>
Maja Bajevic

● ●
<meta itemprop="startDate" content="2009-02-15">
<meta itemprop="endDate" content="2009-05-03">
<p class="date">15.02.–03.05.2009</p>
Davide Cascio

●
<meta itemprop="startDate" content="2009-09-06">
<meta itemprop="endDate" content="2009-11-22">
<p class="date">06.09.–22.11.2009</p>

● ●
<meta itemprop="startDate" content="2009-02-15">
<meta itemprop="endDate" content="2009-05-03">
<p class="date">15.02.–03.05.2009</p>
Nina Fischer & Maroan El Sani

2010

Total number of programs: 8

Exhibitions by contemporary artists: 7 (87.5%)

Exhibitions of the collection: 1 (12.5%)

Unkown category: 0 (0.0%)

Total number of participating artists in exhibitions: 34

International artist: 15 (44.1%)

Lokal artist: 1 (3.0%)

Swiss artist: 18 (52.9%)



Programs

● ●
<meta itemprop="startDate" content="2010-12-05">
<meta itemprop="endDate" content="2011-01-17">
<p class="date">05.12.2010–17.01.2011</p>
<div class="artists">

● ●
<meta itemprop="startDate" content="2010-09-05">
<meta itemprop="endDate" content="2010-11-21">
<p class="date">05.09.–21.11.2010</p>
Falke Pisano & Ana Roldan

● ●
<meta itemprop="startDate" content="2010-12-05">
<meta itemprop="endDate" content="2011-01-17">
<p class="date">05.12.2010–17.01.2011</p>
Ingrid Käser

●
<meta itemprop="startDate" content="2010-09-05">
<meta itemprop="endDate" content="2010-11-21">
<p class="date">05.09.–21.11.2010</p>

● ●
<meta itemprop="startDate" content="2010-09-05">
<meta itemprop="endDate" content="2010-11-21">
<p class="date">05.09.–21.11.2010</p>
Alexandra Bachzetsis

● ●
<meta itemprop="startDate" content="2010-05-16">
<meta itemprop="endDate" content="2010-08-15">
<p class="date">16.05.–15.08.2010</p>
<div class="artists">

● ●
<meta itemprop="startDate" content="2010-09-05">
<meta itemprop="endDate" content="2010-11-21">
<p class="date">05.09.–21.11.2010</p>
Johanna Billing

● ●
<meta itemprop="startDate" content="2010-02-07">
<meta itemprop="endDate" content="2010-05-02">
<p class="date">07.02.–02.05.2010</p>
<div class="artists">

2011

Total number of programs: 8

Exhibitions by contemporary artists: 6 (75.0%)

Exhibitions of the collection: 2 (25.0%)

Unkown category: 0 (0.0%)

Total number of participating artists in exhibitions: 22

International artist: 10 (45.4%)

Lokal artist: 4 (18.2%)

Swiss artist: 8 (36.4%)



Programs

- [Everything but Arms](#)
<meta itemprop="startDate" content="2011-11-13">
<meta itemprop="endDate" content="2012-01-22">
<p class="date">13.11.2011–22.01.2012</p>
Annette Amberg
- [Lass uns eine kleine Reise in den Süden machen](#)
<meta itemprop="startDate" content="2011-08-21">
<meta itemprop="endDate" content="2011-10-30">
<p class="date">21.08.–30.10.2011</p>
<div class="artists">
- [Topics Values](#)
<meta itemprop="startDate" content="2011-11-13">
<meta itemprop="endDate" content="2012-01-22">
<p class="date">13.11.2011–22.01.2012</p>
Neil Beloufa
- [\(RE\)CONSTRUCTED](#)
<meta itemprop="startDate" content="2011-05-15">
<meta itemprop="endDate" content="2011-08-07">
<p class="date">15.05.–07.08.2011</p>
<div class="artists">
- [Neuzugänge der Sammlung des Glarner Kunstvereins 2011](#)
<meta itemprop="startDate" content="2011-11-13">
<meta itemprop="endDate" content="2012-01-22">
<p class="date">13.11.2011–22.01.2012</p>
- [Livingroom Exotica](#)
<meta itemprop="startDate" content="2011-02-06">
<meta itemprop="endDate" content="2011-05-01">
<p class="date">06.02.–01.05.2011</p>
<div class="artists">
- [Resorts](#)
<meta itemprop="startDate" content="2011-08-21">
<meta itemprop="endDate" content="2011-10-30">
<p class="date">21.08.–30.10.2011</p>
Vanessa Safavi
- [Coming Together](#)
<meta itemprop="startDate" content="2011-02-06">
<meta itemprop="endDate" content="2011-05-01">
<p class="date">06.02.–01.05.2011</p>
Daniel Silver

2012

Total number of programs: 8

Exhibitions by contemporary artists: 7 (87.5%)

Exhibitions of the collection: 1 (12.5%)

Unkown category: 0 (0.0%)

Total number of participating artists in exhibitions: 19

International artist: 8 (42.1%)

Lokal artist: 2 (10.5%)

Swiss artist: 9 (47.4%)

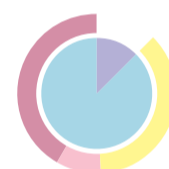

Programs

- [Kunstschaffen Glarus und Linthgebiet A-H 2012](#)
<meta itemprop="startDate" content="2012-12-02">
<meta itemprop="endDate" content="2013-01-20">
<p class="date">02.12.2012–20.01.2013</p>
<div class="artists">
- [Those Animals That, At a Distance, Resemble Flies](#)
<meta itemprop="startDate" content="2012-05-20">
<meta itemprop="endDate" content="2012-08-19">
<p class="date">20.05.–19.08.2012</p>
João Maria Gusmão + Pedro Paiva
- [Fokus-Preis 2012](#)
<meta itemprop="startDate" content="2012-12-02">
<meta itemprop="endDate" content="2013-01-20">
<p class="date">02.12.2012–20.01.2013</p>
Claudio Zopfi
- [Neuzugänge der Sammlung des Glarner Kunstvereins 2012](#)
<meta itemprop="startDate" content="2012-05-20">
<meta itemprop="endDate" content="2012-08-19">
<p class="date">20.05.–19.08.2012</p>
- [The Exoteric Wall](#)
<meta itemprop="startDate" content="2012-09-09">
<meta itemprop="endDate" content="2012-11-18">
<p class="date">09.09.–18.11.2012</p>
Louise Hervé & Chloé Maillet
- [Works](#)
<meta itemprop="startDate" content="2012-02-12">
<meta itemprop="endDate" content="2012-05-06">
<p class="date">12.02.–06.05.2012</p>
Daniel Gustav Cramer
- [Unter 30 VIII - Junge Schweizer Kunst](#)
<meta itemprop="startDate" content="2012-09-09">
<meta itemprop="endDate" content="2012-11-18">
<p class="date">09.09.–18.11.2012</p>
<div class="artists">
- [The Infinite Library](#)
<meta itemprop="startDate" content="2012-02-12">
<meta itemprop="endDate" content="2012-05-06">
<p class="date">12.02.–06.05.2012</p>
Daniel Gustav Cramer & Haris Epaminonda

2013

Total number of programs: 8

Exhibitions by contemporary artists: 7 (87.5%)

Exhibitions of the collection: 1 (12.5%)

Unkown category: 0 (0.0%)

Total number of participating artists in exhibitions: 7

International artist: 4 (57.1%)

Lokal artist: 1 (14.3%)

Swiss artist: 2 (28.6%)

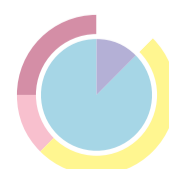

Programs

- [Kunstschaffen Glarus und Linthgebiet I-Q 2013](#)
<meta itemprop="startDate" content="2013-12-08">
<meta itemprop="endDate" content="2014-01-19">
<p class="date">08.12.2013–19.01.2014</p>
<div class="artists">
- [Fokus-Preis 2013](#)
<meta itemprop="startDate" content="2013-12-08">
<meta itemprop="endDate" content="2014-01-19">
<p class="date">08.12.2013–19.01.2014</p>
Nicole Hoesli
- [Urnerknabe am Schaufenster / Empathie](#)
<meta itemprop="startDate" content="2013-09-01">
<meta itemprop="endDate" content="2013-11-24">
<p class="date">01.09.–24.11.2013</p>
Yorgos Sapountzis
- [Last Night](#)
<meta itemprop="startDate" content="2013-09-01">
<meta itemprop="endDate" content="2013-11-24">
<p class="date">01.09.–24.11.2013</p>
Martin Beck
- [Thursday Followed Wednesday and Tuesday Followed Monday and...](#)
<meta itemprop="startDate" content="2013-05-19">
<meta itemprop="endDate" content="2013-08-11">
<p class="date">19.05.–11.08.2013</p>
Luca Frei
- [A Walk in the Park](#)
<meta itemprop="startDate" content="2013-02-10">
<meta itemprop="endDate" content="2013-05-05">
<p class="date">10.02.–05.05.2013</p>
Adrien Missika
- [Listen](#)
<meta itemprop="startDate" content="2013-02-10">
<meta itemprop="endDate" content="2013-05-05">
<p class="date">10.02.–05.05.2013</p>
Robert Kinmont
- [Rund um 47° N, 9° O, über 800 m.ü.M](#)
<meta itemprop="startDate" content="2013-02-10">
<meta itemprop="endDate" content="2013-05-05">
<p class="date">10.02.–05.05.2013</p>
<div class="artists">

2014

Total number of programs: 8

Exhibitions by contemporary artists: 6 (75.0%)
Exhibitions of the collection: 1 (12.5%)
Unkown category: 1 (12.5%)

Total number of participating artists in exhibitions: 8

International artist: 3 (37.5%)
Lokal artist: 2 (25.0%)
Swiss artist: 3 (37.5%)



Programs

- [Kunstschaffen Glarus und Linthgebiet R-Z 2014](#)
<meta itemprop="startDate" content="2014-12-07">
<meta itemprop="endDate" content="2015-01-18">
<p class="date">07.12.2014–18.01.2015</p>
<div class="artists">
- [Fokus-Preis 2014](#)
<meta itemprop="startDate" content="2014-12-07">
<meta itemprop="endDate" content="2015-01-18">
<p class="date">07.12.2014–18.01.2015</p>
KARIEL
- [Coupé-décalé](#)
<meta itemprop="startDate" content="2014-08-24">
<meta itemprop="endDate" content="2014-11-23">
<p class="date">24.08.–23.11.2014</p>
Bastien Aubry / Dimitri Broquard
- [Là-bas.](#)
<meta itemprop="startDate" content="2014-08-24">
<meta itemprop="endDate" content="2014-11-23">
<p class="date">24.08.–23.11.2014</p>
Saâdane Afif
- [Werke von Pablo Picasso und der Cobra Gruppe](#)
<meta itemprop="startDate" content="2014-08-24">
<meta itemprop="endDate" content="2014-11-23">
<p class="date">24.08.–23.11.2014</p>
- [A Place Like This](#)
<meta itemprop="startDate" content="2014-05-25">
<meta itemprop="endDate" content="2014-08-10">
<p class="date">25.05.–10.08.2014</p>
<div class="artists">
- [Learning to Love](#)
<meta itemprop="startDate" content="2014-02-09">
<meta itemprop="endDate" content="2014-05-04">
<p class="date">09.02.–04.05.2014</p>
Guillaume Pilet
- [Rocky](#)
<meta itemprop="startDate" content="2014-02-09">
<meta itemprop="endDate" content="2014-05-04">
<p class="date">09.02.–04.05.2014</p>
Nina Beier

2015

Total number of programs: 6

Exhibitions by contemporary artists: 4 (66.6%)
Exhibitions of the collection: 1 (16.7%)
Unkown category: 1 (16.7%)

Total number of participating artists in exhibitions: 28

International artist: 13 (46.4%)
Lokal artist: 1 (3.6%)
Swiss artist: 14 (50.0%)



Programs

- [New Glarus. Kunstschaffen ausserordentlich Glarus u. Linthgebiet 2015](#)
<meta itemprop="startDate" content="2015-12-06">
<meta itemprop="endDate" content="2016-01-24">
<p class="date">06.12.2015–24.01.2016</p>
<div class="artists">
- [Unter 30 XI. Junge Schweizer Kunst. Kiefer Hablitzel Preis 2015](#)
<meta itemprop="startDate" content="2015-09-06">
<meta itemprop="endDate" content="2015-11-22">
<p class="date">06.09.–22.11.2015</p>
<div class="artists">

● ●
<meta itemprop="startDate" content="2015-05-17">
<meta itemprop="endDate" content="2015-08-16">
<p class="date">17.05.–16.08.2015</p>
<div class="artists">

<meta itemprop="startDate" content="2015-05-17">
<meta itemprop="endDate" content="2015-08-16">
<p class="date">17.05.–16.08.2015</p>
<div class="artists">

● ●
<meta itemprop="startDate" content="2015-02-08">
<meta itemprop="endDate" content="2015-05-03">
<p class="date">08.02.–03.05.2015</p>
<div class="artists">

●
<meta itemprop="startDate" content="2015-02-08">
<meta itemprop="endDate" content="2015-05-03">
<p class="date">08.02.–03.05.2015</p>

2016

Total number of programs: 7

Exhibitions by contemporary artists: 6 (85.7%)
Exhibitions of the collection: 1 (14.3%)
Unkown category: 0 (0.0%)

Total number of participating artists in exhibitions: 15

International artist: 8 (53.3%)
Lokal artist: 1 (6.7%)
Swiss artist: 6 (40.0%)



Programs

● ●
<meta itemprop="startDate" content="2016-12-11">
<meta itemprop="endDate" content="2017-01-29">
<p class="date">11.12.2016–29.01.2017</p>
<div class="artists">

● ●
<meta itemprop="startDate" content="2016-12-11">
<meta itemprop="endDate" content="2017-01-29">
<p class="date">11.12.2016–29.01.2017</p>

● ●
<meta itemprop="startDate" content="2016-09-04">
<meta itemprop="endDate" content="2016-11-27">
<p class="date">04.09.–27.11.2016</p>

● ●
<meta itemprop="startDate" content="2016-05-22">
<meta itemprop="endDate" content="2016-08-21">
<p class="date">22.05.–21.08.2016</p>

●
<meta itemprop="startDate" content="2016-05-22">
<meta itemprop="endDate" content="2016-08-21">
<p class="date">22.05.–21.08.2016</p>

● ●
<meta itemprop="startDate" content="2016-04-26">
<meta itemprop="endDate" content="2016-05-01">
<p class="date">26.04.–01.05.2016</p>
Alexandra Pirici & Manuel Pelmuş

● ●
<meta itemprop="startDate" content="2016-02-14">
<meta itemprop="endDate" content="2016-05-08">
<p class="date">14.02.–08.05.2016</p>
<div class="artists">

2017

Total number of programs: 10

Exhibitions by contemporary artists: 6 (50.0%)
Exhibitions of the collection: 1 (10.0%)
Unkown category: 4 (40.0%)

Total number of participating artists in exhibitions: 16

International artist: 8 (50.0%)
Lokal artist: 0 (0.0%)
Swiss artist: 8 (50.0%)



Programs

<meta itemprop="startDate" content="2017-12-03">
<meta itemprop="endDate" content="2018-01-28">
<p class="date">03.12.2017–28.01.2018</p>
<div class="artists">

● ●
<meta itemprop="startDate" content="2017-12-03">
<meta itemprop="endDate" content="2018-01-28">
<p class="date">03.12.2017–28.01.2018</p>

●
<meta itemprop="startDate" content="2017-10-22">
<meta itemprop="endDate" content="2017-11-19">
<p class="date">22.10.–19.11.2017</p>
<div class="artists">

<meta itemprop="startDate" content="2017-10-13">
<meta itemprop="endDate" content="2017-10-15">
<p class="date">13.10.–15.10.2017</p>
<div class="artists">

<meta itemprop="startDate" content="2017-08-13">
<meta itemprop="endDate" content="2017-10-08">
<p class="date">13.08.–08.10.2017</p>
<div class="artists">

<meta itemprop="startDate" content="2017-05-28">
<meta itemprop="endDate" content="2017-07-30">
<p class="date">28.05.–30.07.2017</p>
<div class="artists">

[!\[\]\(50ba758255c5d7cec2761495a31c7c80_img.jpg\) !\[\]\(4991d58d1e01404b6cc46722865f5a5a_img.jpg\)
<meta itemprop="startDate" content="2017-05-28">
<meta itemprop="endDate" content="2017-07-30">
<p class="date">28.05.–30.07.2017</p>](#)

[!\[\]\(529949c2c3dadbaa4e538e8c643454bc_img.jpg\) !\[\]\(9d83b67c094360bb3c4e3b68ca3d779f_img.jpg\)
<meta itemprop="startDate" content="2017-03-12">
<meta itemprop="endDate" content="2017-05-14">
<p class="date">12.03.–14.05.2017</p>](#)

[!\[\]\(3dfb8d66e81160ad61421a3452093d1b_img.jpg\) !\[\]\(21ece2018b00c7267b3324c50bbed633_img.jpg\)
<meta itemprop="startDate" content="2017-03-12">
<meta itemprop="endDate" content="2017-05-14">
<p class="date">12.03.–14.05.2017</p>](#)

[!\[\]\(99f58673407353e96a019fbca558fd72_img.jpg\) !\[\]\(2113e5cba4d11862fa536c379e9b61cd_img.jpg\)
<meta itemprop="startDate" content="2017-02-12">
<meta itemprop="endDate" content="2017-02-26">
<p class="date">12.02.–26.02.2017</p>
<div class="artists">](#)

2018

Total number of programs: 4
Exhibitions by contemporary artists: 4 (100%)
Exhibitions of the collection: 0 (0.0%)
Unkown category: 0 (0.0%)

Total number of participating artists in exhibitions: 9
International artist: 5 (55.6%)
Lokal artist: 1 (11.1%)
Swiss artist: 3 (33.3%)

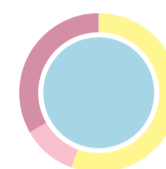

Programs

[!\[\]\(6059a5aa8b4ca7bb793408023d6c6e42_img.jpg\) !\[\]\(d293b9aef7d8767760396289fbc64e8a_img.jpg\)
<meta itemprop="startDate" content="2018-12-09">
<meta itemprop="endDate" content="2019-01-13">
<p class="date">09.12.2018–13.01.2019</p>
<div class="artists">](#)

[!\[\]\(c50c8b7b2cc2cf9ff925edec0ee94c0d_img.jpg\) !\[\]\(8bed43dc33ecdde61e2f76c8f5517125_img.jpg\)
<meta itemprop="startDate" content="2018-09-23">
<meta itemprop="endDate" content="2018-11-11">
<p class="date">23.09.–11.11.2018</p>
<div class="artists">](#)

[!\[\]\(6a9b39b98eb945faa14c645ec99e4eaa_img.jpg\) !\[\]\(182077db5bac9ff62bf376fe37ffa951_img.jpg\)
<meta itemprop="startDate" content="2018-05-27">
<meta itemprop="endDate" content="2018-08-19">
<p class="date">27.05.–19.08.2018</p>](#)

[!\[\]\(9c2e8d1b5bd77cb5c9f83b7a9cff79fd_img.jpg\) !\[\]\(f822cba4d3f2ea10b4ad95c475f0f631_img.jpg\)
<meta itemprop="startDate" content="2018-03-18">
<meta itemprop="endDate" content="2018-05-13">
<p class="date">18.03.–13.05.2018</p>](#)

2019

Total number of programs: 4
Exhibitions by contemporary artists: 2 (50.0%)
Exhibitions of the collection: 1 (25.0%)
Unkown category: 1 (25.0%)

Total number of participating artists in exhibitions: 2
International artist: 2 (100.0%)
Lokal artist: 0 (0.0%)
Swiss artist: 0 (0.0%)



Programs

[!\[\]\(83bbbd261710c59db0214aa27b2edc0d_img.jpg\) !\[\]\(d6bd620f45f20291c3c3dab29f2286e8_img.jpg\)
<meta itemprop="startDate" content="2019-10-27">
<meta itemprop="endDate" content="2020-01-01">
<p class="date">27.10.2019–01.01.2020</p>](#)

[!\[\]\(166772600a13ad0a433053f90fe45649_img.jpg\)
<meta itemprop="startDate" content="2019-10-27">
<meta itemprop="endDate" content="2020-03-01">
<p class="date">27.10.2019–01.03.2020</p>
<div class="artists">](#)

[!\[\]\(291e070cef6c4d5e78fefe4696ef53be_img.jpg\) !\[\]\(5a6551557c623b42379c503783a5133a_img.jpg\)
<meta itemprop="startDate" content="2019-06-30">
<meta itemprop="endDate" content="2019-11-10">
<p class="date">30.06.–10.11.2019</p>](#)

[!\[\]\(a73c1962d20a39dd8fd6a060ae69693f_img.jpg\)
<meta itemprop="startDate" content="2019-05-18">
<meta itemprop="endDate" content="2019-05-18">
<p class="date">18.05.</p>](#)

2020

Total number of programs: 7
Exhibitions by contemporary artists: 6 (71.4%)
Exhibitions of the collection: 1 (14.3%)
Unkown category: 1 (14.3%)

Total number of participating artists in exhibitions: 13
International artist: 6 (46.1%)
Lokal artist: 3 (23.1%)
Swiss artist: 4 (30.8%)



Programs

[!\[\]\(26cddea01ddf7f002af4ba779c4999ee_img.jpg\) !\[\]\(6904bb7f8eb436becdb64d9ce0b725e2_img.jpg\)
<meta itemprop="startDate" content="2020-12-13">
<meta itemprop="endDate" content="2021-03-14">
<p class="date">13.12.2020–14.03.2021</p>](#)

[!\[\]\(b78e2d0769ad682766c36e077fde3d60_img.jpg\)
<meta itemprop="startDate" content="2020-12-13">
<meta itemprop="endDate" content="2021-03-14">
<p class="date">13.12.2020–14.03.2021</p>
<div class="artists">](#)

● ●
<meta itemprop="startDate" content="2020-12-13">
<meta itemprop="endDate" content="2021-03-14">
<p class="date">13.12.2020–14.03.2021</p>

● ●
<meta itemprop="startDate" content="2020-09-05">
<meta itemprop="endDate" content="2020-11-29">
<p class="date">05.09.–29.11.2020</p>
<div class="artists">

<meta itemprop="startDate" content="2020-03-15">
<meta itemprop="endDate" content="2020-08-23">
<p class="date">15.03.–23.08.2020</p>

● ●
<meta itemprop="startDate" content="2020-03-15">
<meta itemprop="endDate" content="2020-08-23">
<p class="date">15.03.–23.08.2020</p>

● ●
<meta itemprop="startDate" content="2020-01-12">
<meta itemprop="endDate" content="2020-03-01">
<p class="date">12.01.–01.03.2020</p>

2021

Total number of programs: 6

Exhibitions by contemporary artists: 4 (66.6%)

Exhibitions of the collection: 0 (0.0%)

Unkown category: 2 (33.4%)

Total number of participating artists in exhibitions: 4

International artist: 3 (75.0%)

Lokal artist: 0 (0.0%)

Swiss artist: 1 (25.0%)



Programs

<meta itemprop="startDate" content="2021-12-12">
<meta itemprop="endDate" content="2022-02-06">
<p class="date">12.12.2021–06.02.2022</p>
<div class="artists">

● ●
<meta itemprop="startDate" content="2021-12-12">
<meta itemprop="endDate" content="2022-02-06">
<p class="date">12.12.2021–06.02.2022</p>

● ●
<meta itemprop="startDate" content="2021-09-05">
<meta itemprop="endDate" content="2021-11-28">
<p class="date">05.09.–28.11.2021</p>

● ●
<meta itemprop="startDate" content="2021-09-05">
<meta itemprop="endDate" content="2021-11-28">
<p class="date">05.09.–28.11.2021</p>

● ●
<meta itemprop="startDate" content="2021-06-06">
<meta itemprop="endDate" content="2021-08-22">
<p class="date">06.06.–22.08.2021</p>

<meta itemprop="startDate" content="2021-03-28">
<meta itemprop="endDate" content="2021-05-24">
<p class="date">28.03.–24.05.2021</p>

2022

Total number of programs: 9

Exhibitions by contemporary artists: 6 (66.7%)

Exhibitions of the collection: 2 (22.2%)

Unkown category: 1 (11.1%)

Total number of participating artists in exhibitions: 6

International artist: 5 (83.3%)

Lokal artist: 1 (16.7%)

Swiss artist: 0 (0.0%)



Programs

● ●
<meta itemprop="startDate" content="2022-12-11">
<meta itemprop="endDate" content="2023-02-05">
<p class="date">11.12.2022–05.02.2023</p>
<div class="artists">

● ●
<meta itemprop="startDate" content="2022-09-04">
<meta itemprop="endDate" content="2022-11-27">
<p class="date">04.09.–27.11.2022</p>

● ●
<meta itemprop="startDate" content="2022-09-04">
<meta itemprop="endDate" content="2022-11-27">
<p class="date">04.09.–27.11.2022</p>

●
<meta itemprop="startDate" content="2022-09-04">
<meta itemprop="endDate" content="2023-02-05">
<p class="date">04.09.2022–05.02.2023</p>

● ●
<meta itemprop="startDate" content="2022-05-29">
<meta itemprop="endDate" content="2022-08-21">
<p class="date">29.05.–21.08.2022</p>

● ●
<meta itemprop="startDate" content="2022-05-29">
<meta itemprop="endDate" content="2022-08-21">
<p class="date">29.05.–21.08.2022</p>

<meta itemprop="startDate" content="2022-02-20">
<meta itemprop="endDate" content="2022-05-15">
<p class="date">20.02.–15.05.2022</p>

●
<meta itemprop="startDate" content="2022-02-20">
<meta itemprop="endDate" content="2022-08-21">
<p class="date">20.02.–21.08.2022</p>

● ●
<meta itemprop="startDate" content="2022-02-20">
<meta itemprop="endDate" content="2022-05-15">
<p class="date">20.02.–15.05.2022</p>

2023

Total number of programs: 6
Exhibitions by contemporary artists: 3 (50.0%)
Exhibitions of the collection: 3 (50.0%)
Unkown category: 0 (0.0%)

Total number of participating artists in exhibitions: 3
International artist: 2 (66.7%)
Lokal artist: 0 (0.0%)
Swiss artist: 1 (33.3%)



Programs

● ●
<meta itemprop="startDate" content="2023-07-09">
<meta itemprop="endDate" content="2023-11-19">
<p class="date">09.07.–19.11.2023</p>

● ●
<meta itemprop="startDate" content="2023-02-26">
<meta itemprop="endDate" content="2023-06-25">
<p class="date">26.02.–25.06.2023</p>

● ●
<meta itemprop="startDate" content="2023-07-09">
<meta itemprop="endDate" content="2023-11-19">
<p class="date">09.07.–19.11.2023</p>

●
<meta itemprop="startDate" content="2023-02-26">
<meta itemprop="endDate" content="2023-06-25">
<p class="date">26.02.–25.06.2023</p>

●
<meta itemprop="startDate" content="2023-07-09">
<meta itemprop="endDate" content="2023-11-19">
<p class="date">09.07.–19.11.2023</p>

●
<meta itemprop="startDate" content="2023-02-26">
<meta itemprop="endDate" content="2023-06-25">
<p class="date">26.02.–25.06.2023</p>



The chapter Exclusion through Atmosphere deals with the premises of the Kunsthhaus Glarus, focusing on the large picture halls and the sculpture hall. The dimensions of the rooms are very generous in relation to the location and the number of occupants, which makes it challenging to occupy this large rooms for exhibtions, which were also designed by Hans Leuzinger for specific exhibition typologies. This means that it is a challenge for the artists to deal with these spaces, as they have very strong atmospheric characteristics, especially with regard to the lighting conditions with strong grazing light in the sculpture hall or even overexposure through the glass prisms of the roofs in the rooms of the painting exhibition. In addition, due to the open floor plan design, where no thresholds separate the rooms, the acoustics play a major role, resulting in echoes due to the size of the rooms. With the help of pictures of former exhibitions, the handling of the rooms is shown, their size and atmosphere, supplemented by scale drawings of the most important rooms.

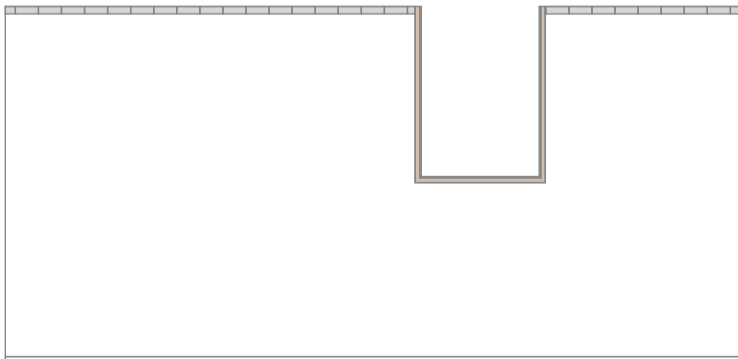
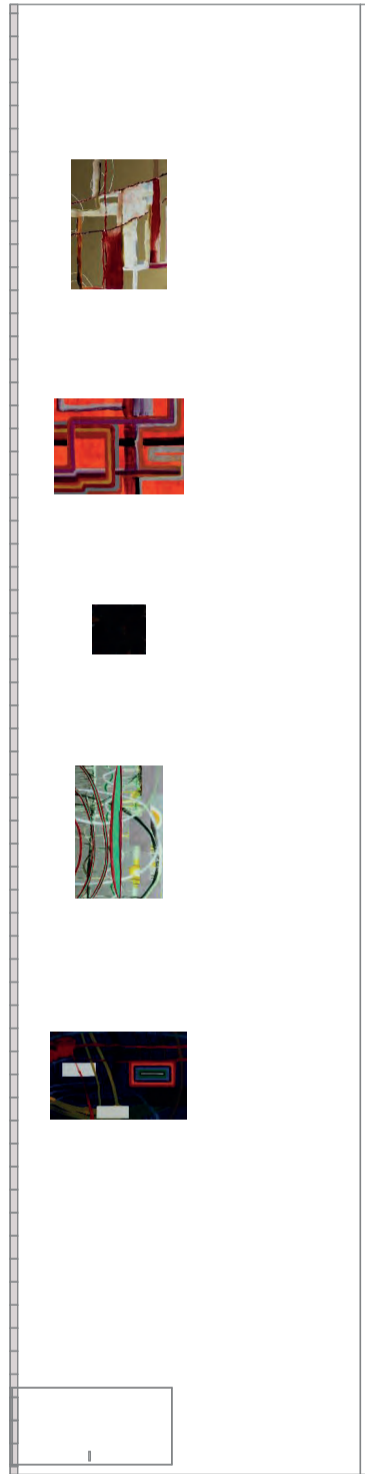
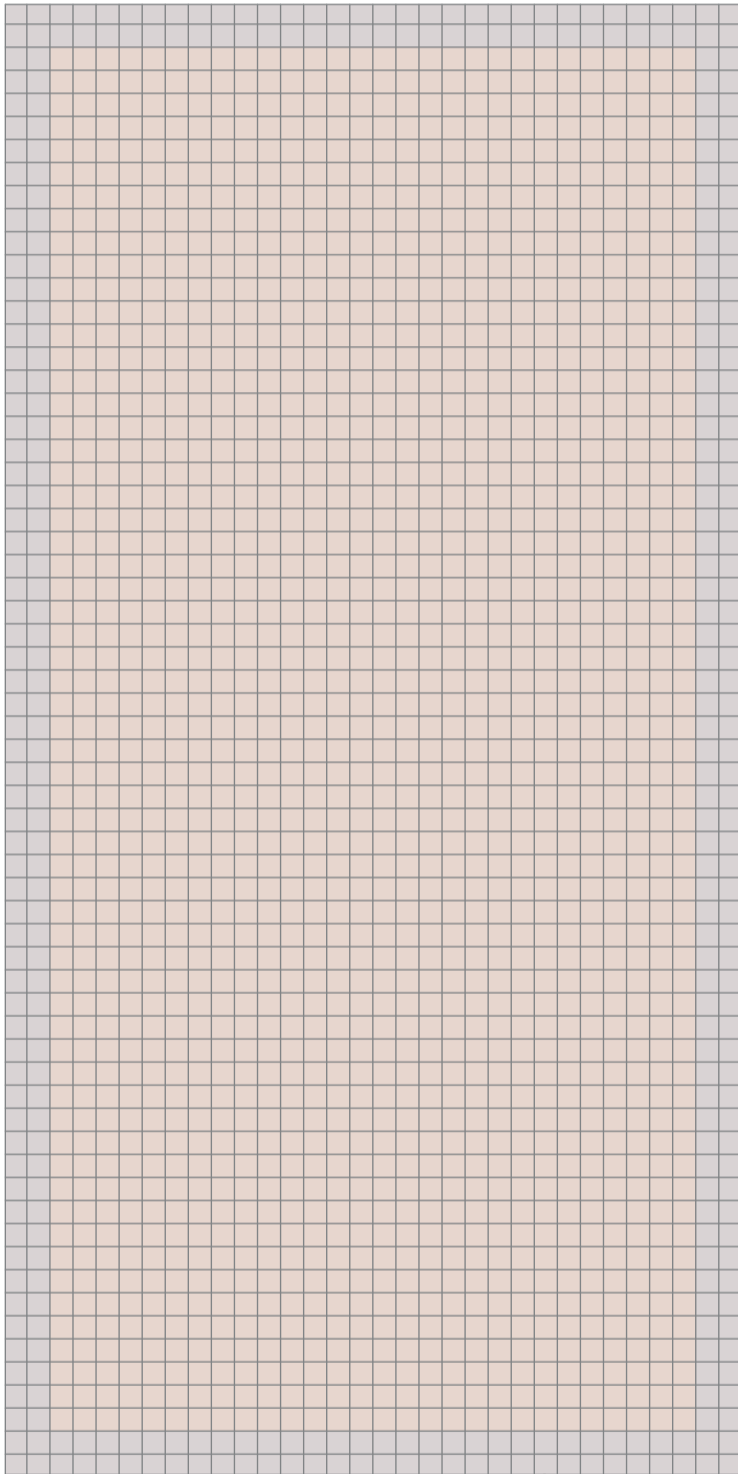
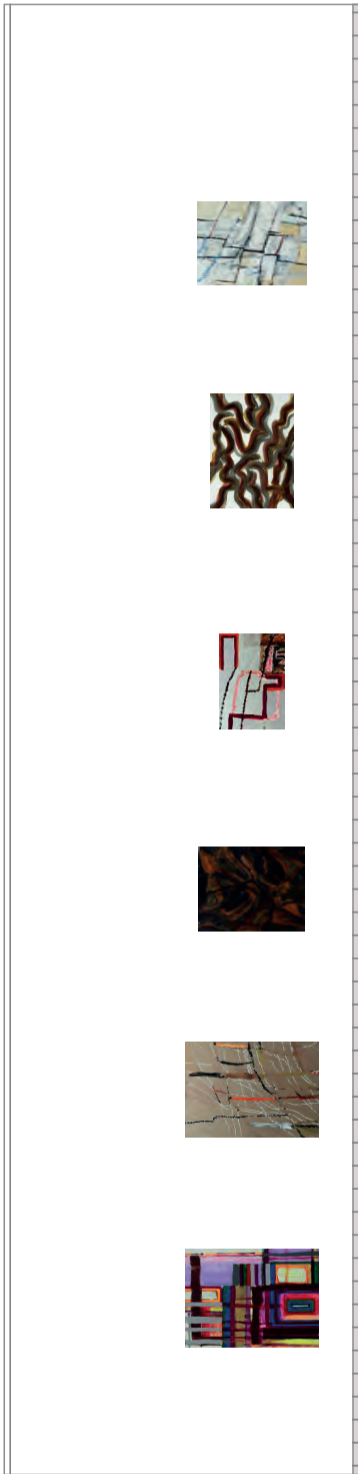
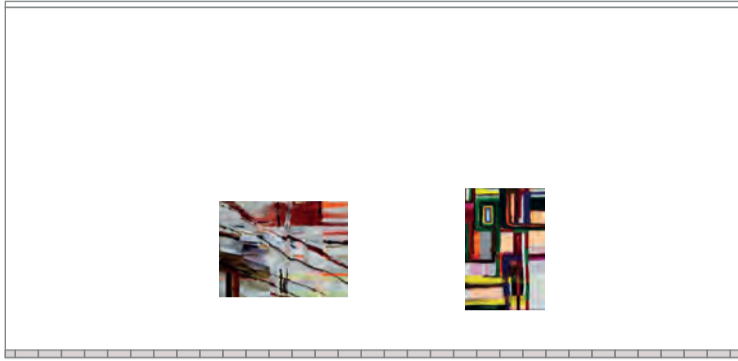



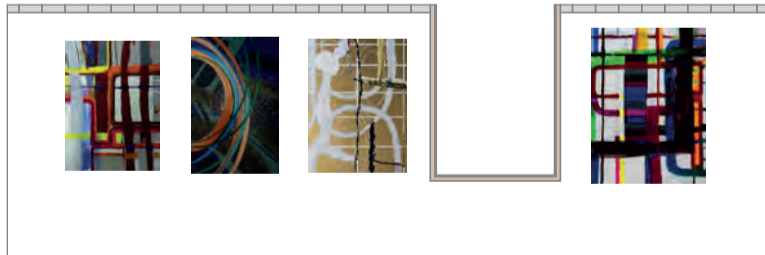
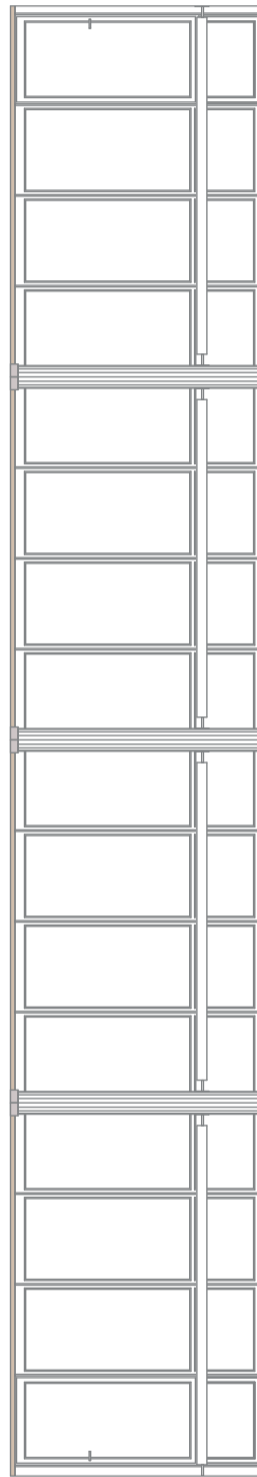
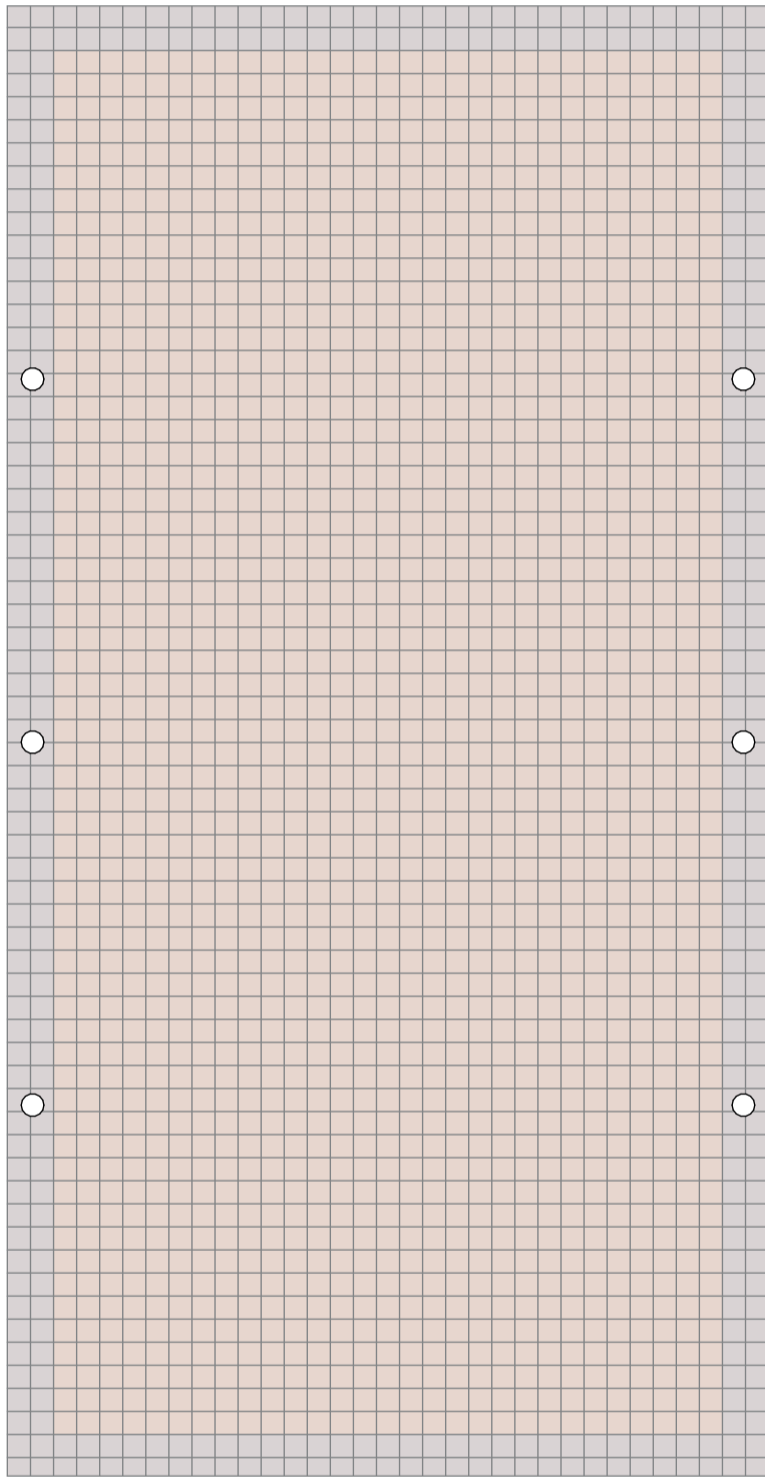
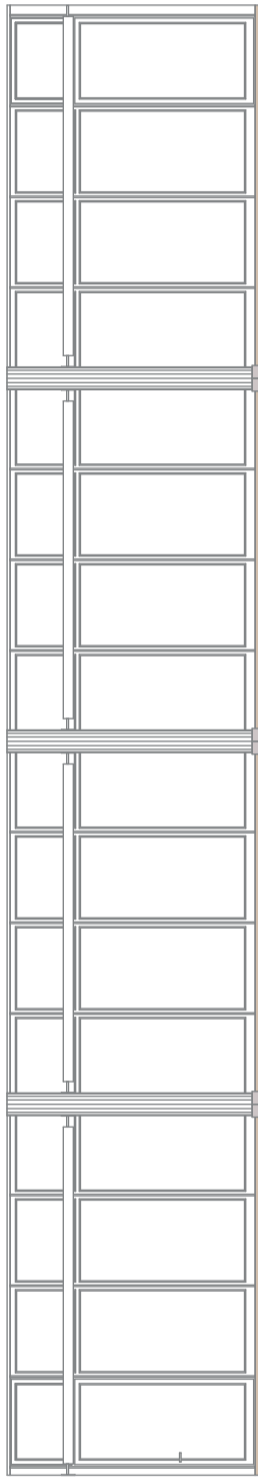
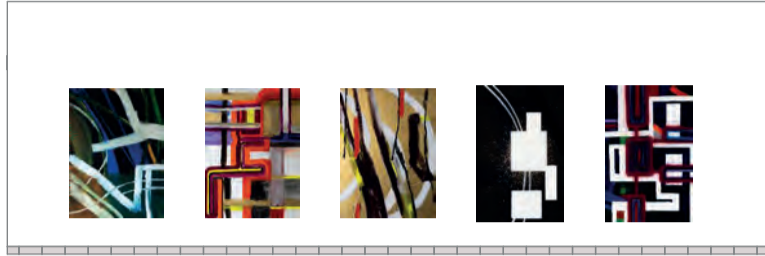

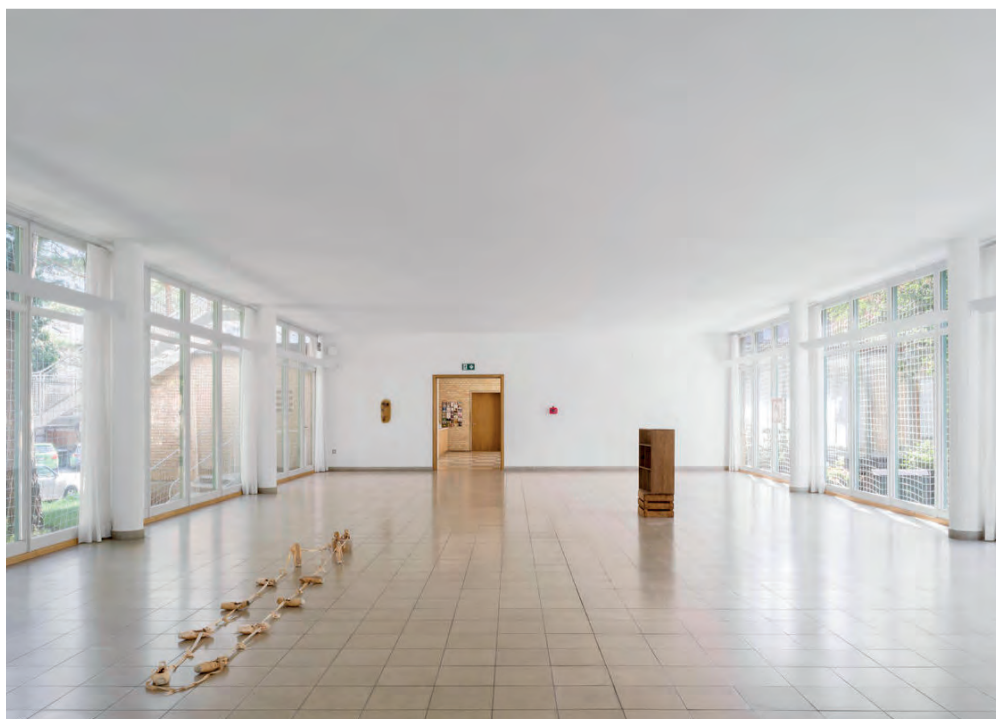
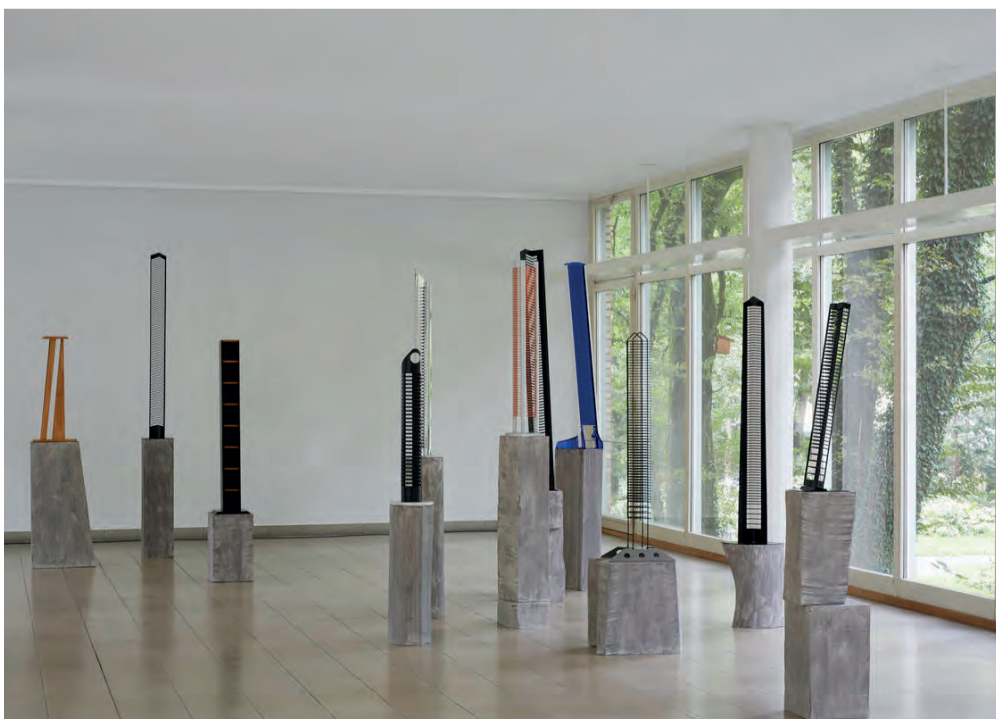
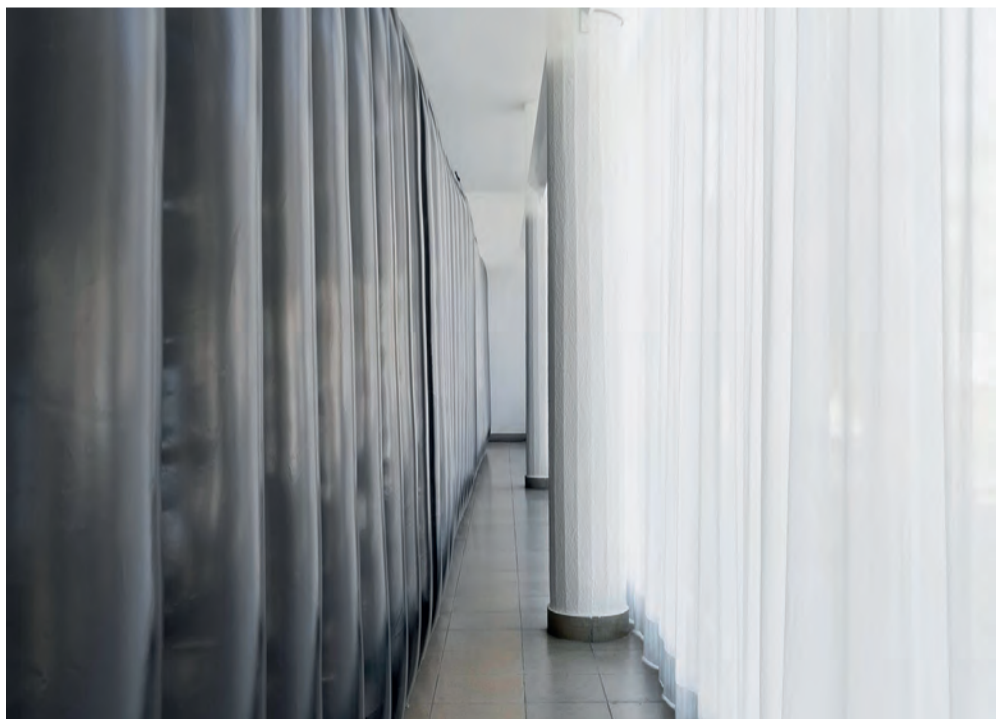

ALLEGORY

KUNSTHAUS GLARUS

MARIUS MUSZYNSKI

Glarnerhof

Bahnhof - Strasse

S. Aufnahme

Brunnen

Konzer 28	Sitz 3 28	Ausstellung	W F	Res.	Leserz 20	Auditor 20	Konze 25
-----------	--------------	-------------	-----	------	-----------	------------	----------

Labor 30	Herb	Leserz.	Halle	Toil. + Garderoben
----------	------	---------	-------	--------------------

Verwaltung

Nat-hist-Sam

Kunst-Sam

pro Geschw. 545m²
total 3 Spind. 1635m²

Bestehende

Gütersch

Mühle - Strasse

The chapter Allegory of Architectural Elements shows that during the design phase Hans Leuzinger was intensively involved with modern buildings from Scandinavia, which had a decisive influence on his design. He adopted and modified certain elements. The question therefore arises as to how far the ideological convictions of Scandinavian modernism, which pay attention to the human scale, influence the population of Glarus and to what extent they can identify with this building and what associations the population has with the architecture.

Östergötlands och Linköpings stads museum, Linköping
Exterior design entrance area of Linköpings stads museum.

Reference for the entrance area, especially the element of water is recognisable.



Kunstners Hus, Oslo
Ornamentation of a brick façade

Reference for the brick ornaments on the wall that encloses the entrance area.



Freibadanlage Letzigraben, Zurich
Finishing wall made of smooth limestone, finishing plate above as rain protection.

Reference for the end wall that encloses the entrance area.





Norrköping
Outdoor recreation area and plinth finish brick facade.
Reference for the plinth transition from the brick facade to the concrete basement.

Kantine Escherwyss, Zurich
Completion of the brick facade up to the roof and window lintel.
Reference for the window lintel and facade termination.

Sammlung Oskar Reinhart am Römerholz, Winterthur
Transparent roof for indirect light of the exhibitions rooms underneath.
Reference for the roof and the Whit box exhibition rooms.

Stadsteater Foaen, Malmö

Lounge area with a view of nature and a continuous band of windows.

Reference for the entrance hall of the Kunsthau Glarus which is also distributor



Östergötlands och Linköpings stads museum, Linköping

Wallenbergsalen in Linköping stads museum as concert hall for events.

Reference for culture multifunctional room in the sub-terrain.



Östergötlands och Linköpings stads museum, Linköping

Exhibition space with continuous window strip and side light.

Reference for sculpture hall with side lightning.

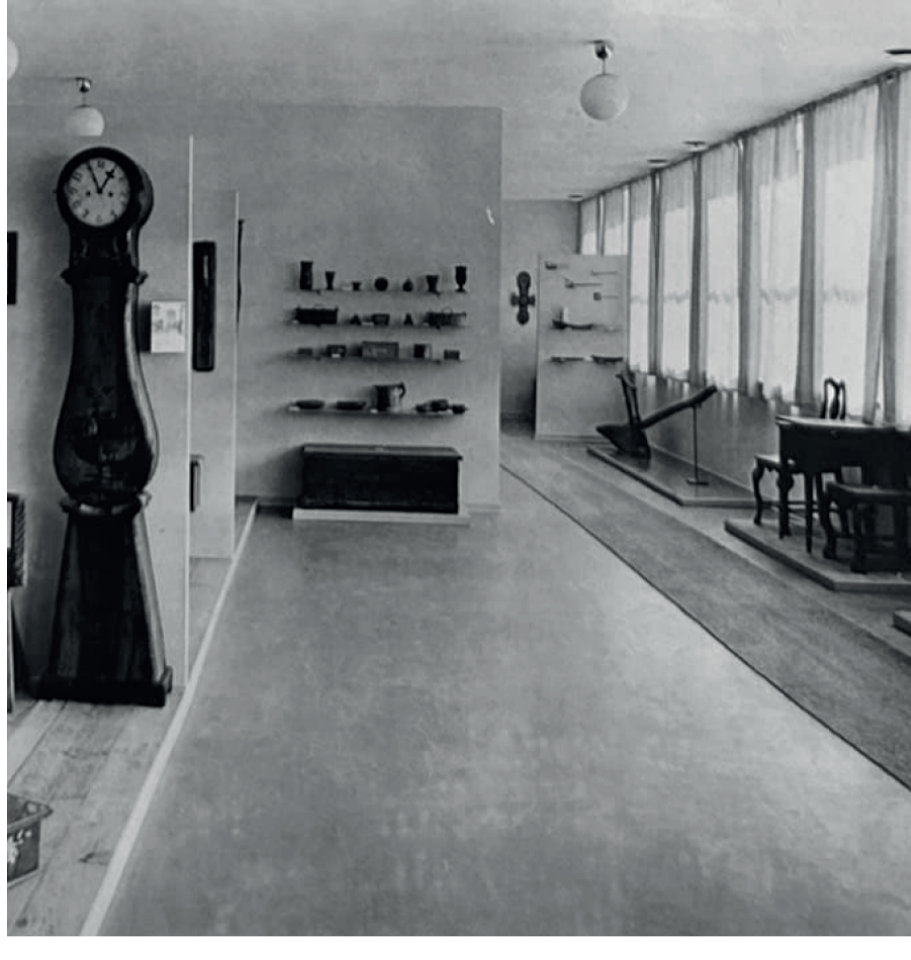

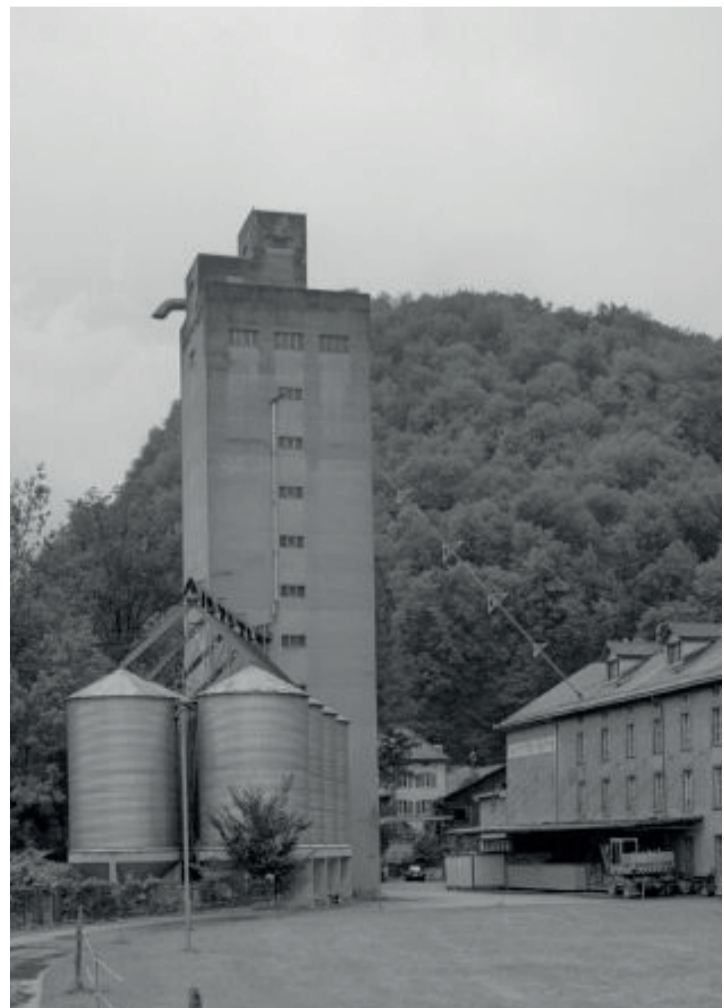

In this chapter, Association of Architectural Elements, a speculative attempt is made to identify connections between the architecture of the Kunsthhaus Glarus and that of its surroundings. To this end, a selection of images on the right-hand side complements the text. These speculative connections arise in particular from the industrial boom in textile production during the 1950s. Thus the glass roofs and the striking chimney are reminiscent of the monumental industrial buildings of the canton of Glarus, with their roofs for drying fabrics. Furthermore, Adolf Max Vogt associates the glass roofs on the one hand with Bruno Taut's city crown, which takes on a new meaning in the rural area and thus creates an association with the mountains.

According to the opinion of Bruno Taut, in every epoch mankind has created an artistic monument in the form of stones that tower over the city. This architecture embodied society with its ideologies and its appearance shone above the city long after its demise. For a long time this lighthouse was dominated by religious buildings or, as Bruno Taut calls it, the crown of the city. In an enlightened society, the question arises as to what the „city crowns“ of the new institutions look like? To what extent do the designs of our forefathers of modernism and postmodernism still correspond to today's social ideas of the population in Glarus, especially when the references for the construction come mostly from another society with its own ideals?

On the other hand, he equates the design with the work of Le Corbusier and his theory that all architecture, even that in Rome, is based on simple geometric forms decorated with ornaments. This association can be seen in the reduced volumetrics of the Kunsthhaus Glarus, but Hans Leuzinger does not strictly follow Le Corbusier's theory; he adds the prism to these geometric shapes, an object that can be found in many other buildings.

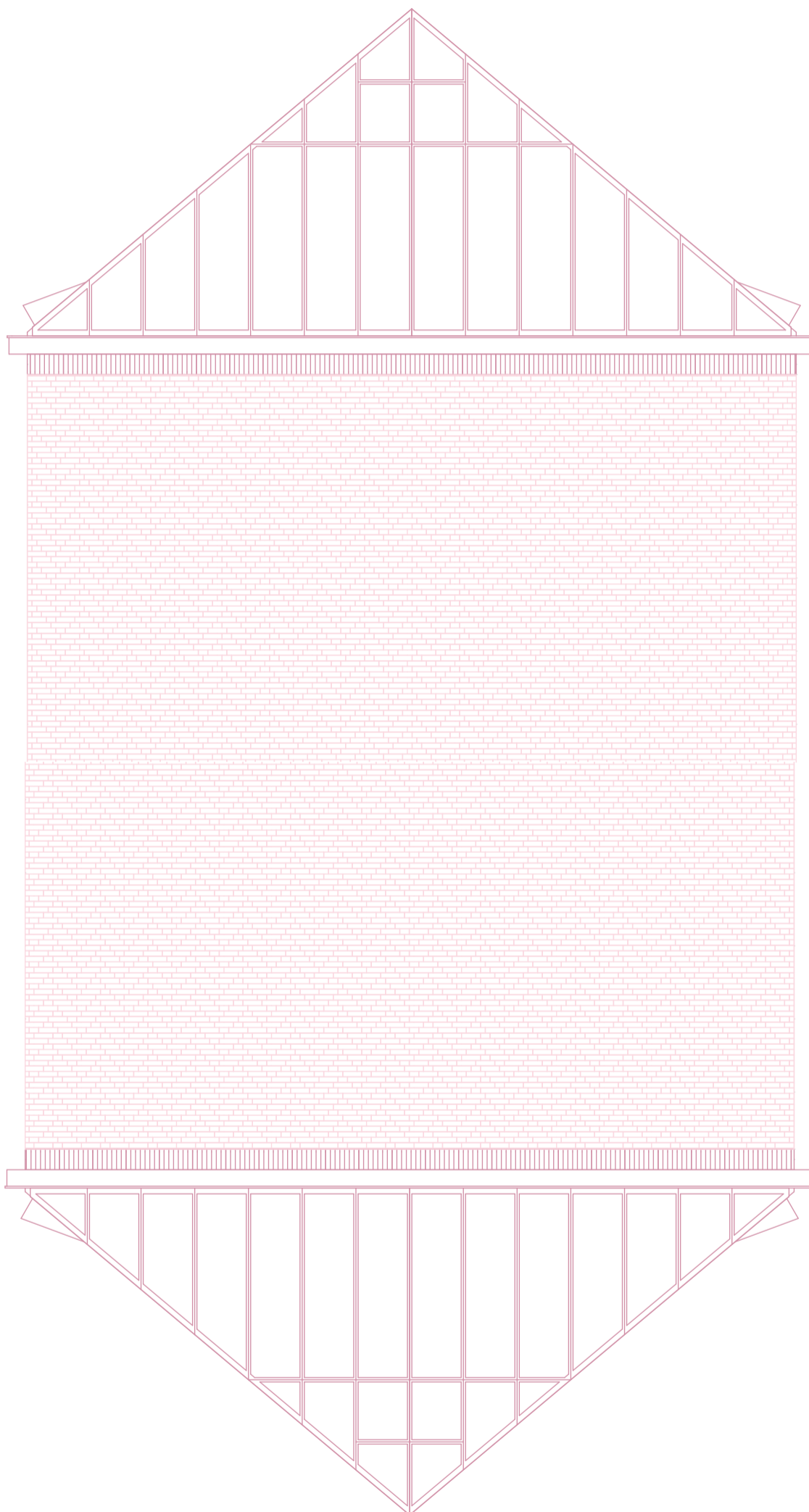

The chapter Restoring like a painting, through a juxtaposition of two images, creates a metaphor of how precise and careful the restoration of Conen/Sigl took place in 2018 with a skapel, preserving the entire external architectural appearance designed by Hans Leuzinger. Thus, the architectural building has been maintained like a painting and thus becomes an art object itself. Any new escape staircases in the external area indicate an architectural intervention, but their form leaves them like sculptures in the public space. Nevertheless, the question arises, do we want to live in a Switzerland that is becoming a museum as Peter Bichsel describes in his book: *Des Schweizern Schweiz* (1969):

„ [...] I shudder at the thought of having to live in a Switzerland that looks like this in twenty years' time. We have become very used to being a museum. We enjoy being admired by foreigners, and anyone who talks about a „special case Switzerland“ is referring to the „Museum Switzerland“ [...]. „

Are not small changes just what can save the Institute Museum from its obsolence?

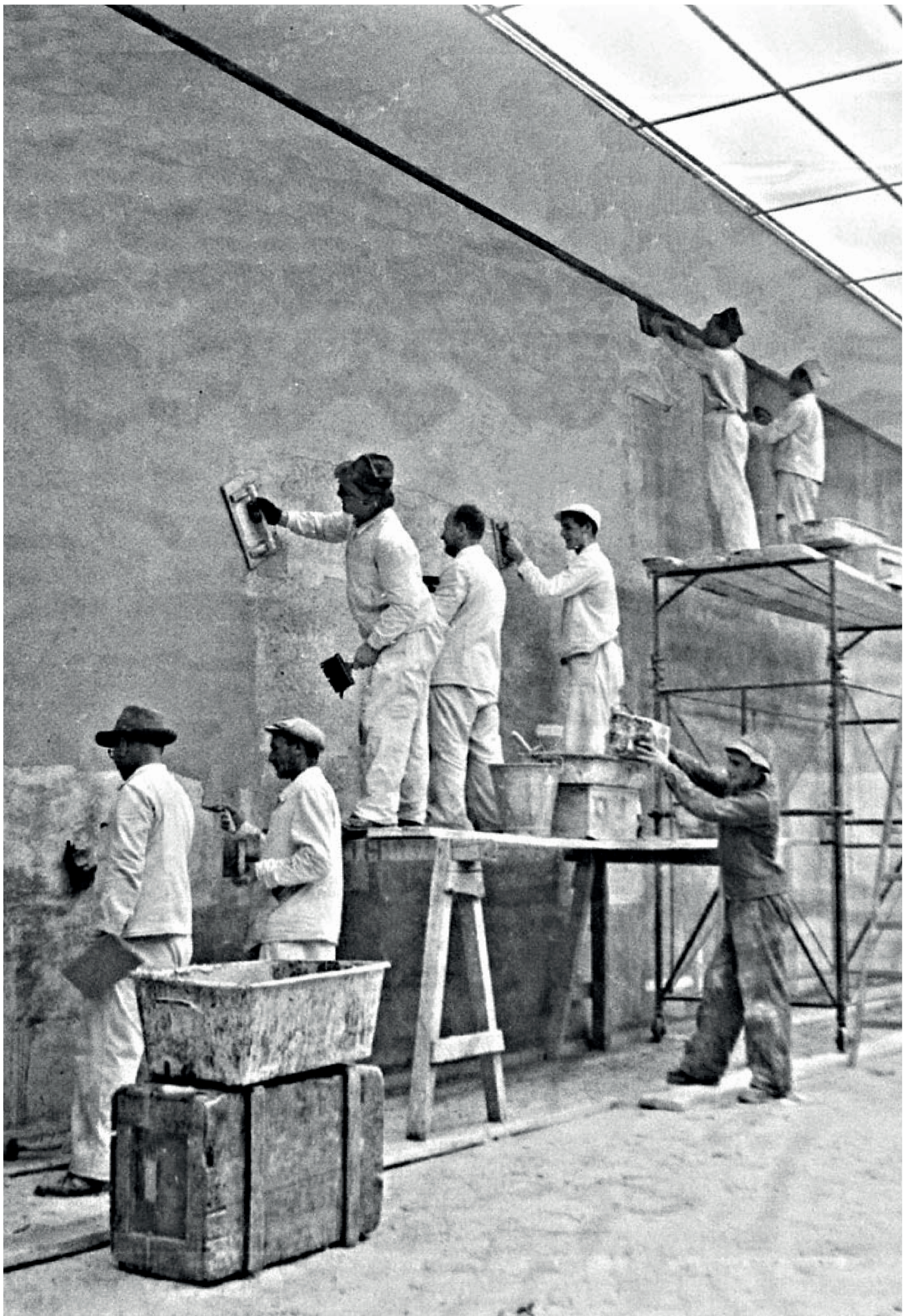



ACCESS

KUNSTHAUS GLARUS

MARIUS MUSZYNSKI

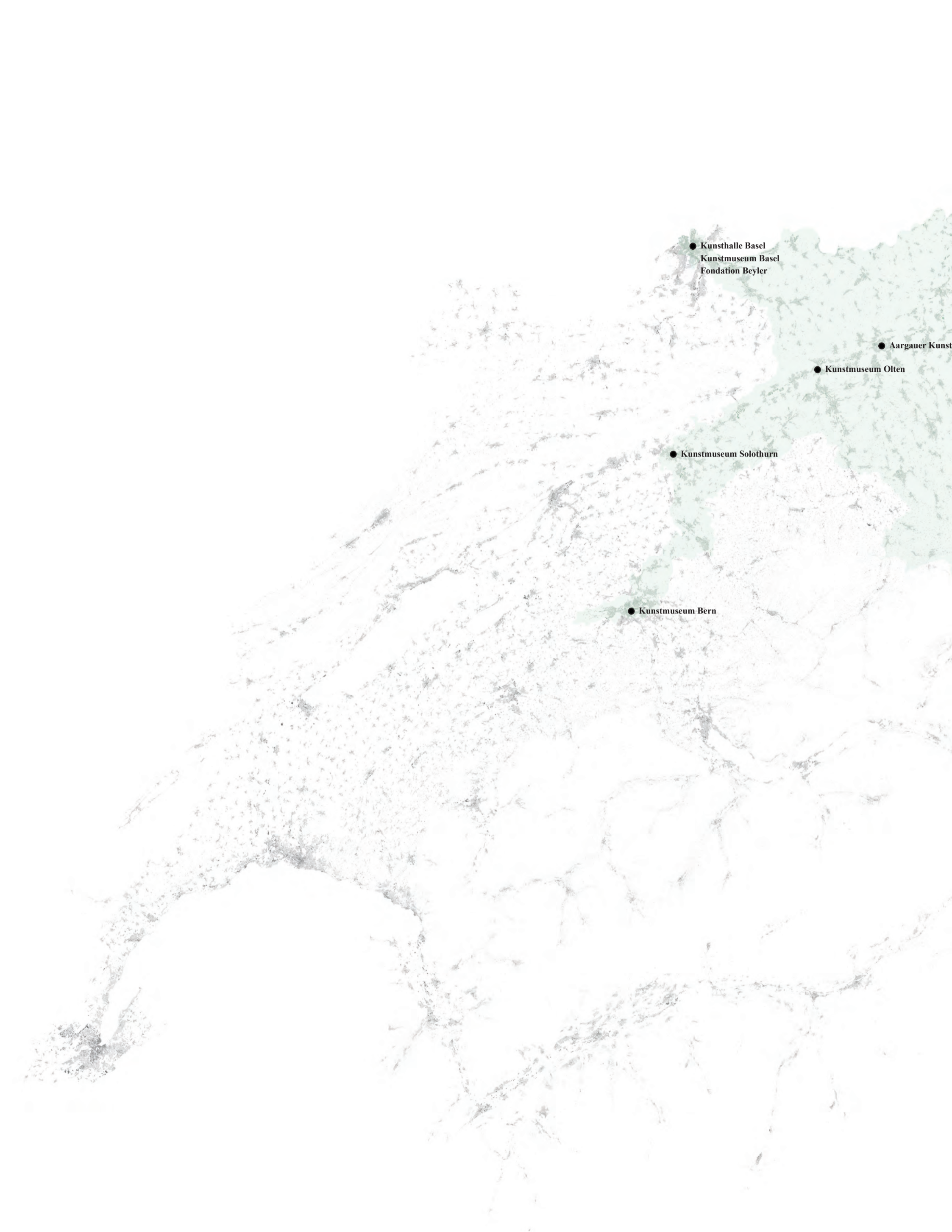

● Kunsthalle Basel
● Kunstmuseum Basel
● Fondation Beyler

● Aargauer Kunst

● Kunstmuseum Olten

● Kunstmuseum Solothurn

● Kunstmuseum Bern

- 1'057'000 People in 1 hour travel time away
- 1 hour travel time from Zurich



If you approach the Kunsthause Glarus from the train station, it first hides behind the planting of the Volksgarten and you only catch a glimpse here and there of the volumetric unique geometry of the building. The brick façade opens only in the area of the sculpture hall and allows a glimpse into the inner life, like in a store window, as one knows it from capitalism. If you walk further along the facade, the question arises, where is the entrance, because apart from a small advertising board, the Kunsthause Glarus is not signposted. In addition, the entrance area is framed by a free-standing wall, which creates a Mediterranean idyll but at the same time hides the entrance. Here the question arises, why Hans Leuzinger has positioned the entrance so that it points away from the city.

According to the study Museum landscape and audience of the museums of Switzerland from 2019 and because data of the BfS live in the canton of Glarus 41,900 people. 23.7% of this population in the canton of Glarus has a compulsory school diploma, 52.1% have completed a secondary education after the compulsory school and 24.2% have attended a university. Of the people with compulsory education, 30% attend a museum in Switzerland, i.e. 2980 people. Among people with secondary education, 42% visit a museum, i.e. 8975 people. People with a university degree are the most likely to visit a museum, namely 64%, which is about 6440 people. According to this calculation, 18400 people in the canton of Glarus would go to the museum at least once a year, but the Kunsthause Glarus has on average only about 3000 visitors per year. The question is therefore what is the reason for this? On the one hand, one can justify this by the short distances and the well connected public transport network, as well as by the large competition in the area of contemporary museums within an hour's travel time. On the other hand, it may also be related to the eternal present in which we live.

We are bombarded with so many images and impressions every second that we are oversaturated and have already forgotten what was the next moment. In other words, you can say that the museum is fighting for the potential audience with Netflix, Instagram, restaurants, travel and so on, and has to reinvent itself every time so that people come and are entertained.

Based on the visitor statistics, you can see that the exhibition of artists in the canton of Glarus is one of the biggest attractions. Therefore, the question arises, what does the local population expect from the Kunsthause in the remaining 11 months and how would they like to use the premises. Can the entrance hall also be an exhibition space or is the exhibition space of the sculpture hall suddenly a library around the button up movement where older people give young children assistance to improve their reading on Wednesday afternoon to strengthen?



Am I a shop window?



Am I also an exhibition space?



Can I be more than a sculpture hall?

References

- gta Archiv: Nachlass Hanz Leuzinger
- Peter Bichsel: Des Schweizern Schweiz, 1969
- Melanie Ohnemus: Discussion with the director of Kunsthauus Glarus
- Judith Weidth: Discussion with the former director of Kunsthauus Glarus Judith Weidth
- Adolf Max Vogt: NZZ article Bauen in den Alpen - neu gesehen.
- Adolf Max Vogt: Das Kunsthauus Glarus eine Alternative zu Le Corbuiser (Essay)
- Stefan Wagner (Technischer Leiter): Email correspondence to get the visitor number of the last 10 year
- List in Chapter Exclusion through time and space - see List | reference in Appendix
- Bruno Traut: Die Stadtkrone

Links

- <https://kunsthauusglarus.ch/de>
- <https://www.bfs.admin.ch/bfs/de/home/statistiken/regionalstatistik/regionale-portraets-kennzahlen/kantone/glarus.html>
- <https://www.swisstopo.admin.ch/de/home.html>
- <https://traveltime.com/blog/how-far-can-i-travel-in-15-minutes-or-1-hour>

Photographs

- Photographs of the Mmodell by Marius Muszynski
- Photographs of Kunsthauus Glarus by Marius Muszynski or <https://kunsthauusglarus.ch/de>
- Photographs from Industrial buildings of Glarus by google Images

In the appendix you will find raw material for the list and references, as well as other documents that have been reviewed.

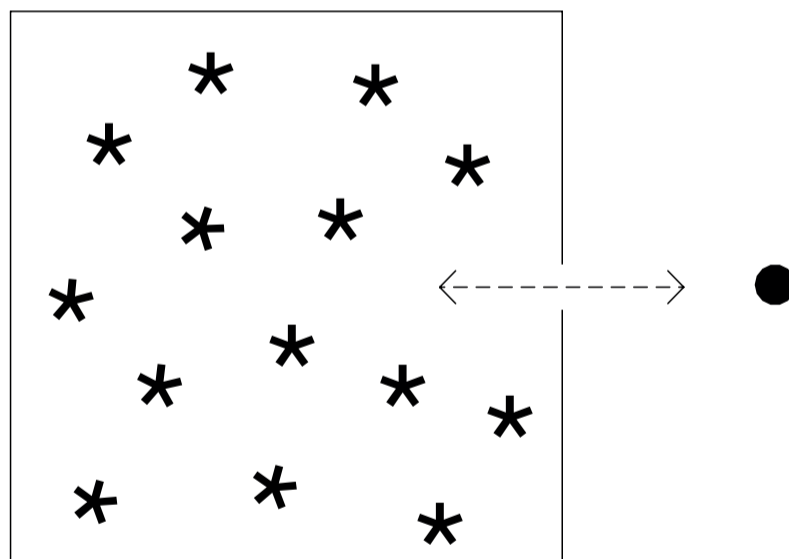
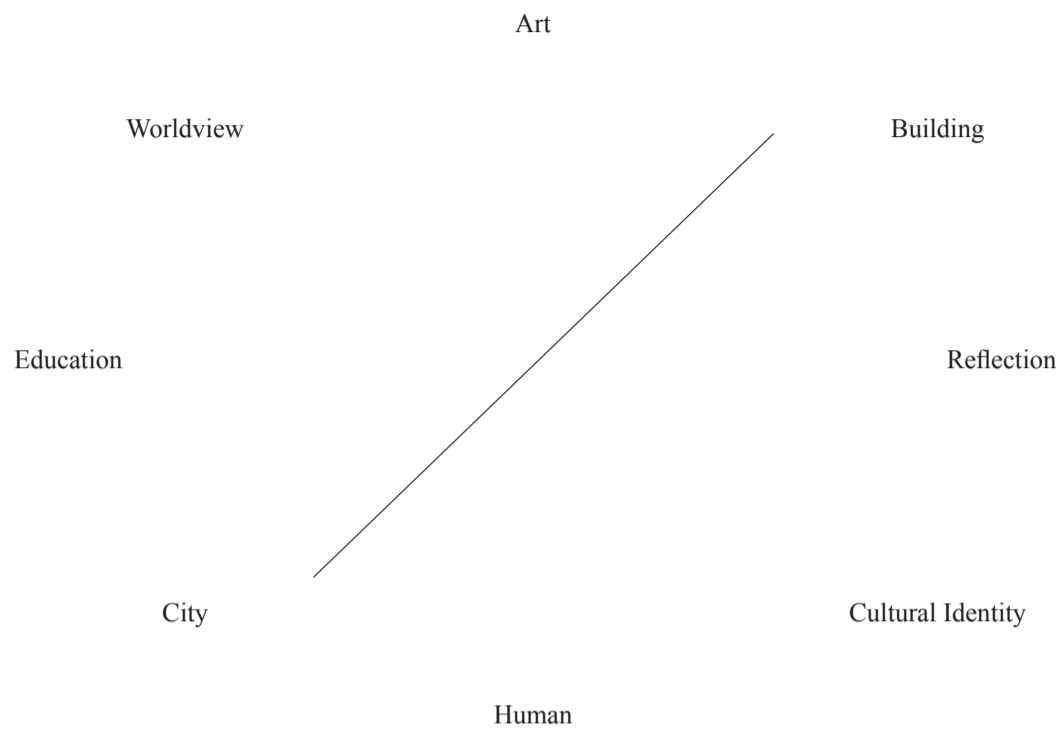

THESAURUS

thesaurus (n.)

1823, „treasury, storehouse,“ from Latin thesaurus „treasury, a hoard, a treasure, something laid up,“ figuratively „repository, collection,“ from Greek thesauros „a treasure, treasury, storehouse, chest,“ related to tithenai „to put, to place.“ The Thesaurus was a Temple to store valuable goods, mostly spoils of war, stolen objects.

The Building had a protective function, much like a bank.

There was no inherent emotional or cultural value in enacting with the objects.

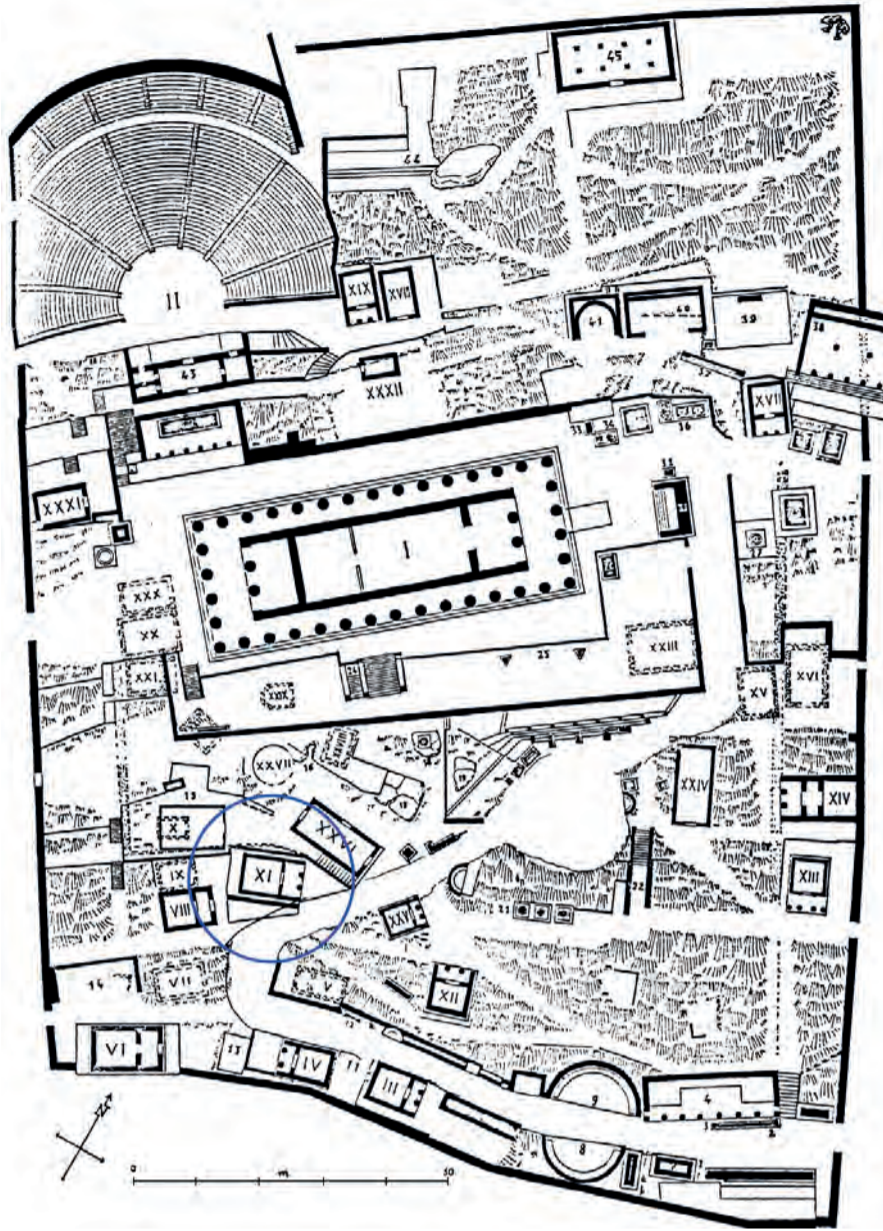

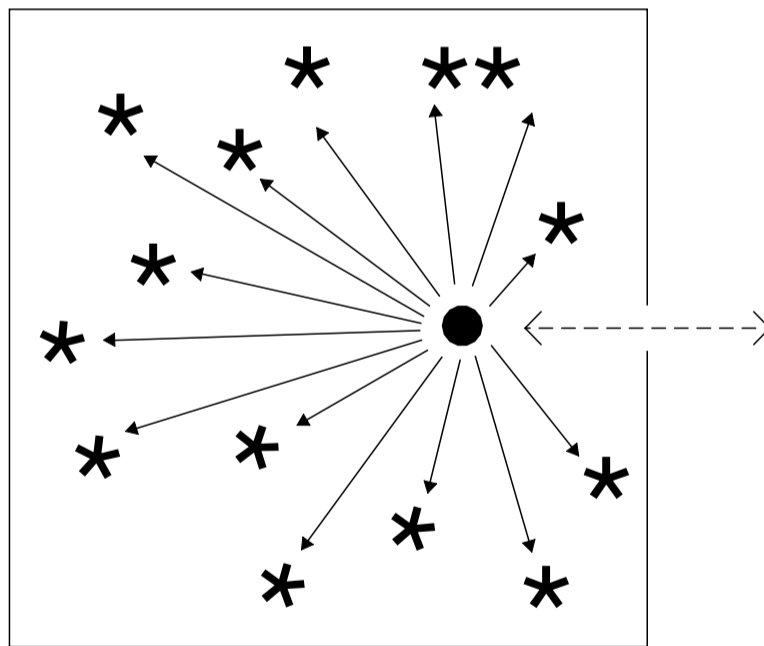
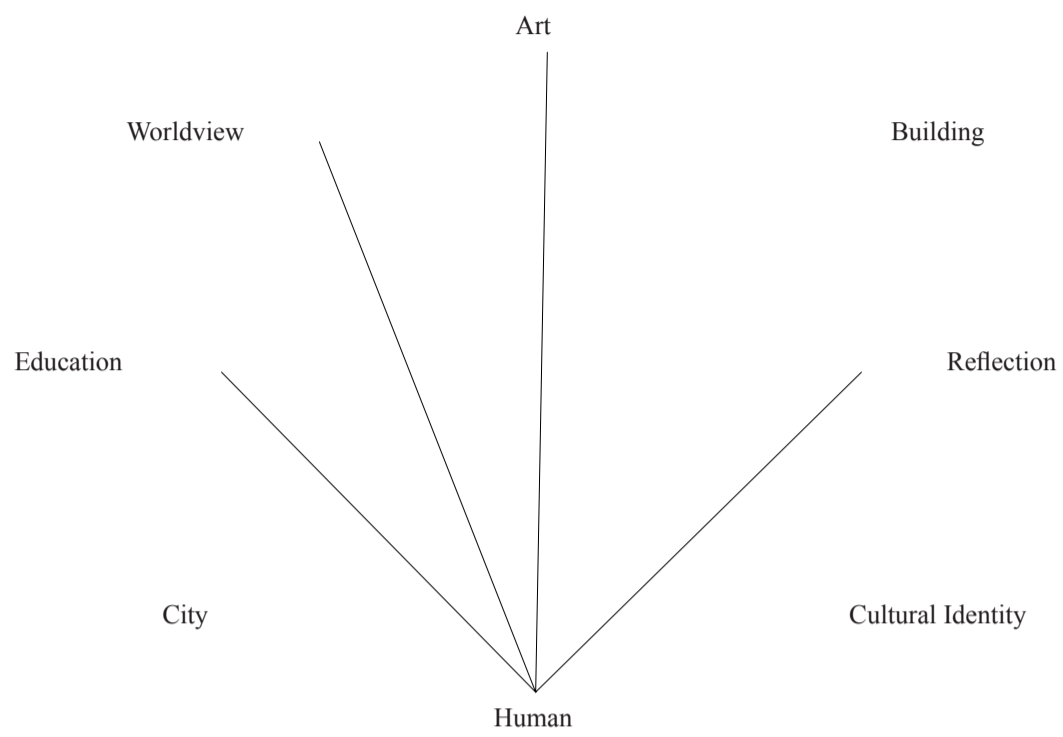

CABINETS OF CURIOSITIES

„Seit frühen Zeiten kultureller Blüte wurden Sammlungen von nicht nur dem Lebensunterhalt dienenden, nicht nur nützlichen, sondern zusätzlich schmückenden, oft durch Material- und Symbolwert kostbaren Gegenständen durch vermögende Personen angelegt.“ (B.Hoppe, Kunstkammern der Spätrenaissance zwischen Kuriosität und Wissenschaft)

The Cabinet of Curiosities were private collections of objects. An evolution of the classical study room. Curated by one person they were reflecting his interest and world view and at the same time validating it.



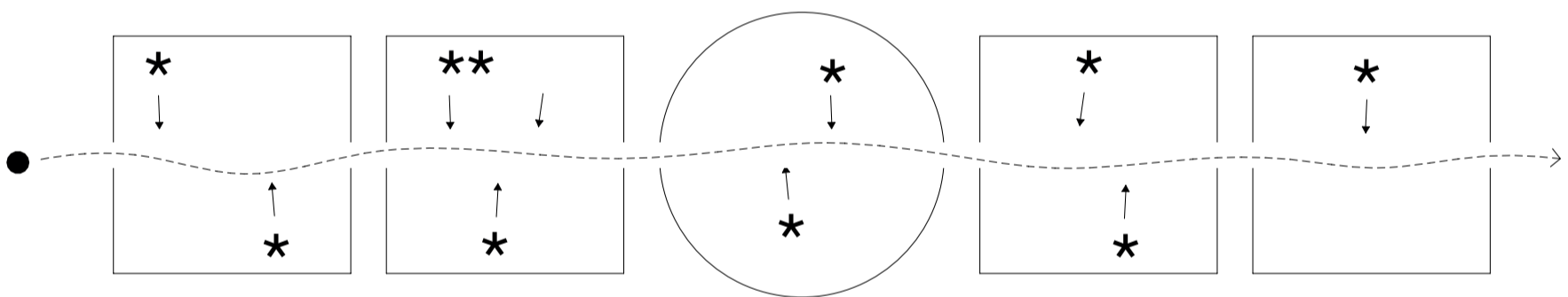
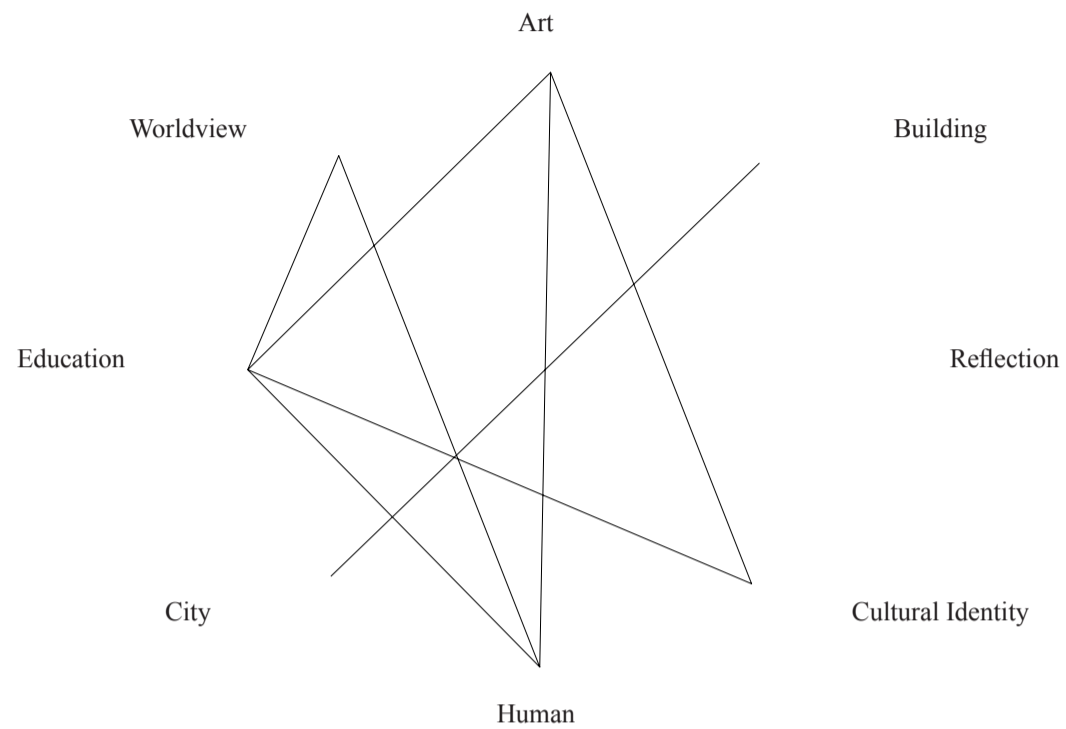

THE FIRST MUSEUMS
MUSÉE DU LOUVRE

Die Französische Revolution enthauptet Ludwig XVII., verstaatlicht die königliche Privatschatulle und verwandelt den Louvre 1793 zum ersten Museum, das jeder allzeit besuchen kann. Seither ist die Institution nicht mehr ohne Öffentlichkeit denkbar. Fortan sind sie Faktoren der öffentlichen Meinungsbildung.

Den Nationalstaaten, die seinerzeit entstehen, liefern sie ihre historische Legitimation.
(Hoffmann, Geschichte und Theorie des Museumsbaus)

BRITISH MUSEUM

The museum was founded in 1753 on the basis of a private collection that was passed on to the state. From its opening in 1759 it was open to the public.

UFFIZIEN

Originally designed as offices for the Medici family in the 16th century, since completion it was always used as a gallery instead. In the beginning to display the private collection to guests. The uffizi opened to the public in 1865.

The first Museums created a classical type that found many forms until the twentieth century. They became places of culture, education and creation of meaning for the visitor.

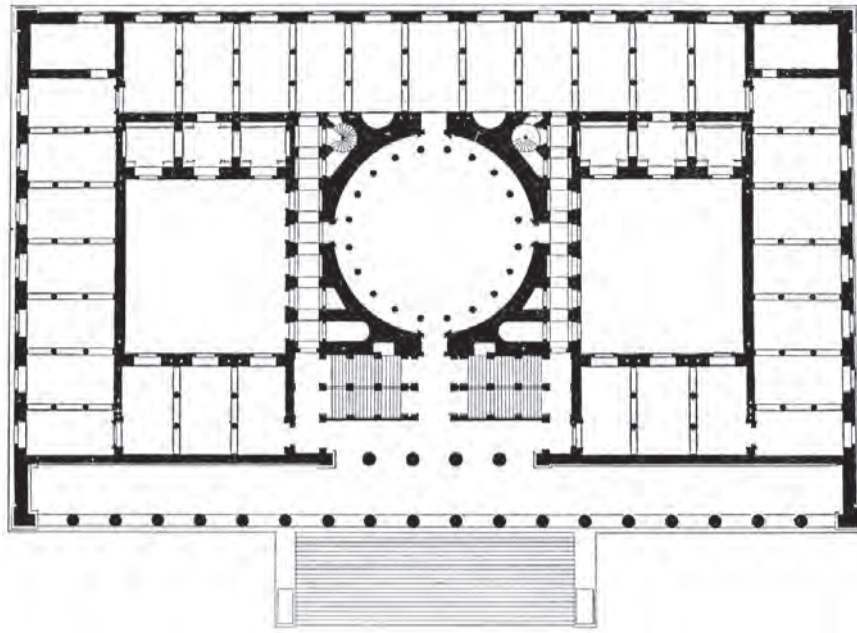

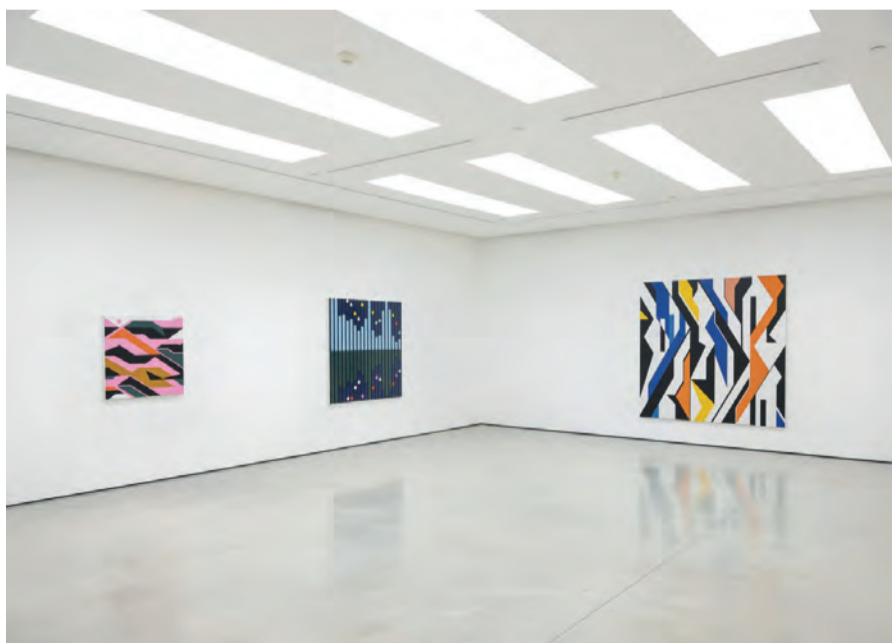
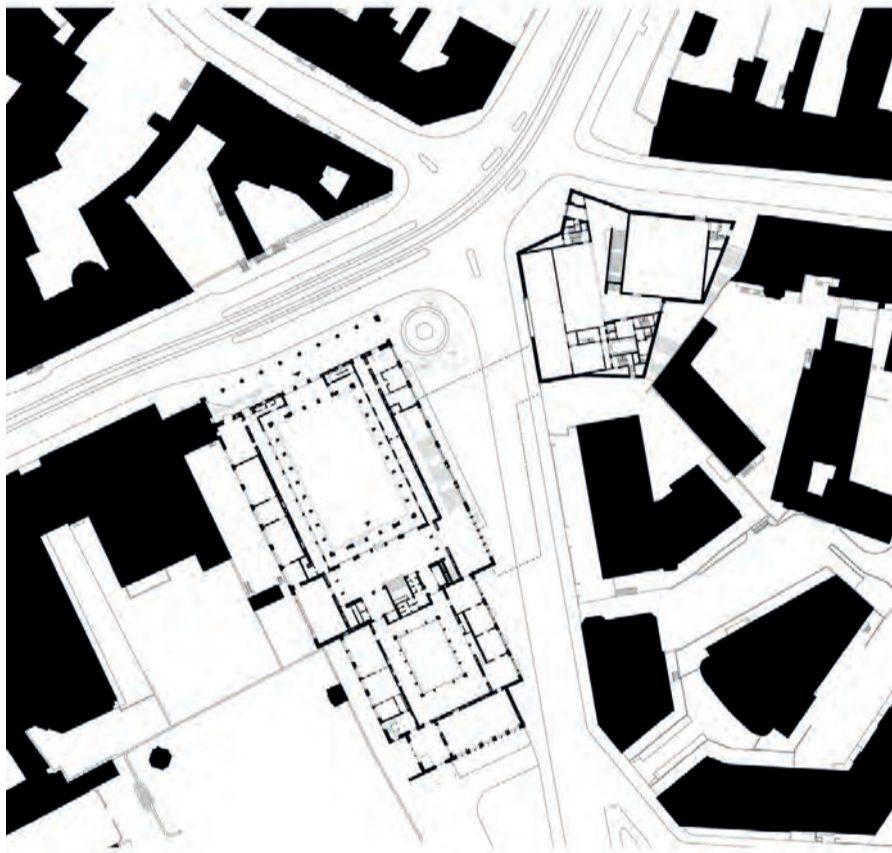

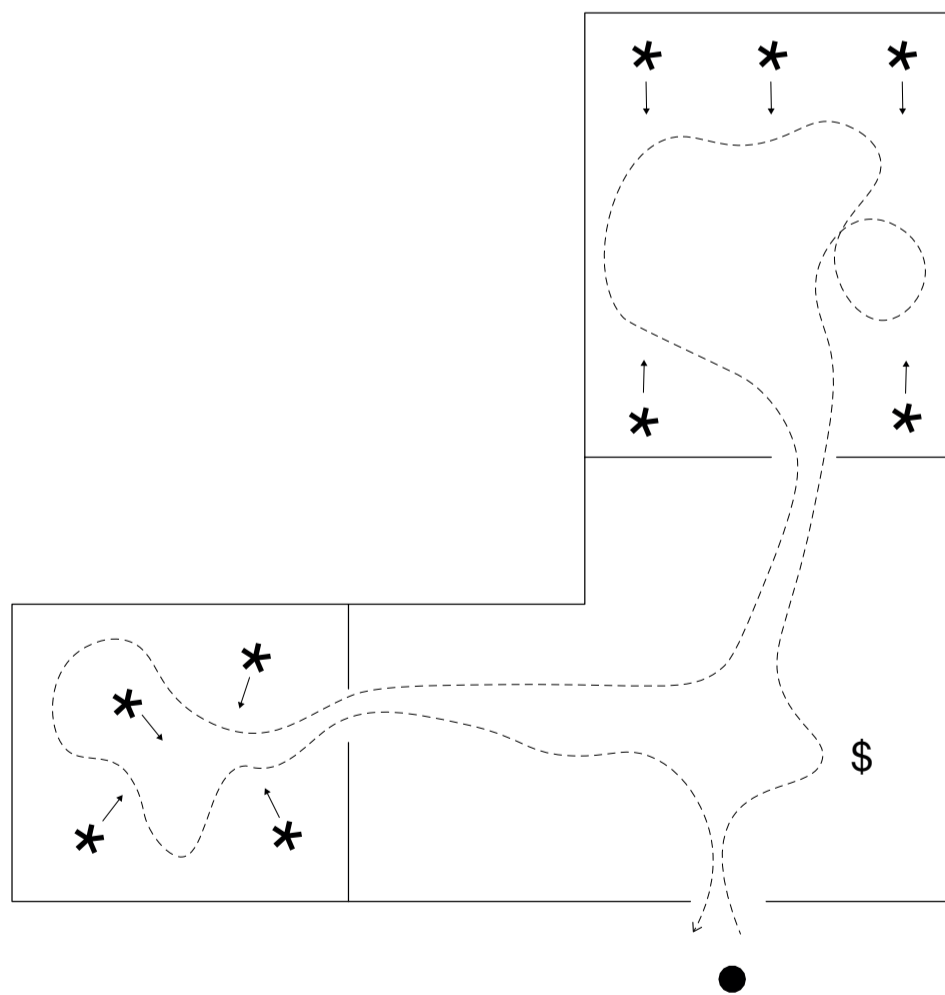
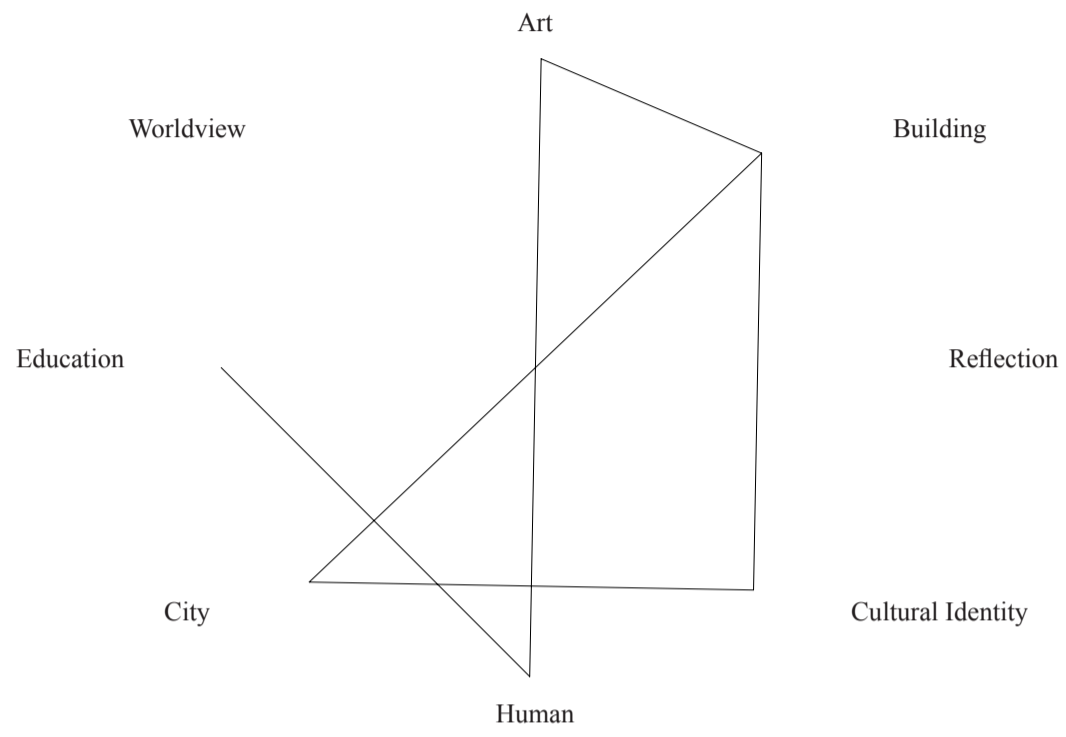

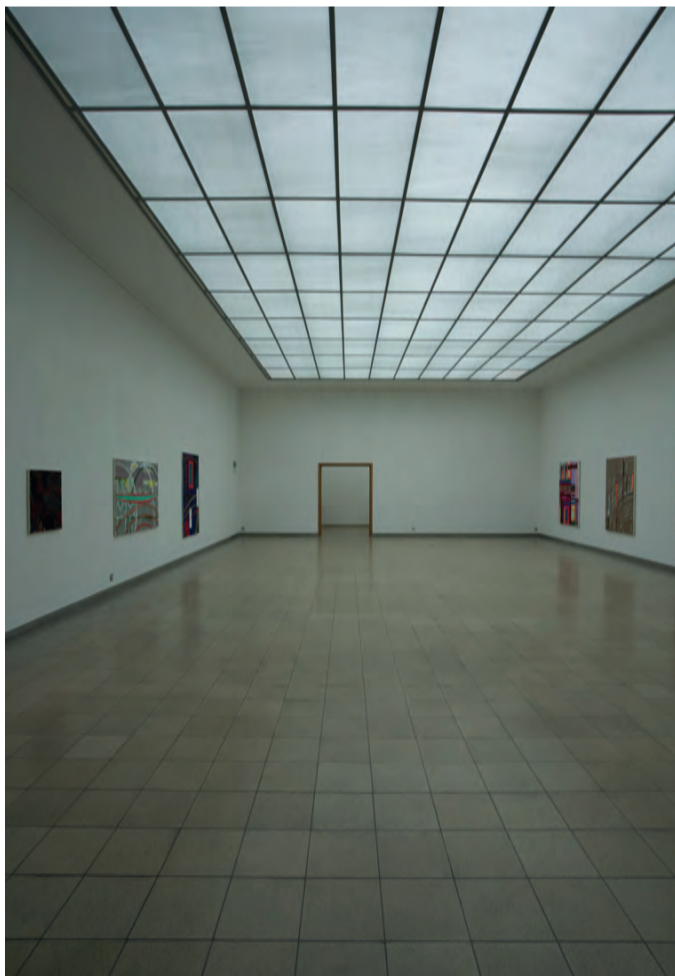

Date	Title	Artist	Gender	Nationality	State City	Age
29.01. - 02.04.1995 ¹	Bernhard Schobinger ¹	Annelies Strba ¹	-	-	-	-
14.04. - 18.06.1995 ¹	Röcke ¹	Simone Ch. Wicki ¹	F	CHE	Zurich	Visual artist
29.06. - 10.09.1995 ¹	Ein Obstadler Fotograf in Oregon ¹	Peter Britt ¹	-	-	-	-
02.07. - 10.09.1995 ¹	Poesies ¹	Helen Chadwick ¹	F	GBR2	London2	-
28.01. - 24.03.1996 ¹	Das Wort das Spiel - das Bild ¹	Prof. Peter Jenny ¹	M 7	CHE 7	Glarus 7	-
23.06. - 01.09.1996 ¹	Strategien der Kunst in den 90er Jahren [Klöntal Sommer] ¹	Various	Various	Various	Various	Various
		Ursula Biemann ¹	F 5	CHE 5	Zurich 5	-
		Maurus Gmür ¹	M 5	CHE 5	Luzern 5	-
		Klara Schilinger ¹	F 6	CHE 6	Luzern 6	-
		Valerian Maly ¹	F 6	DEU 6	Tübingen 6	-
		Peter Spilmann ¹	M 5	CHE 5	Bern 5	-
15.09. - 17.11.1996 ¹	-	Monika Dillier ¹	F 5	CHE 5	Obwalden 5	-
17.04. - 15.06.1997 ¹	-	Paul Fröhlich ¹	M 5	CHE 5	Glarus 5	-
04.05. - 15.06.1997 ¹	-	Zoe Leonard ¹	F 8	USA 8	New York 8	-
29.06. - 31.08.1997 ¹	oberdub	Various ¹	Various	Various	Various	Various
		Eric Schumacher ¹	M 5	CHE 5	Zurich 5	-
		Andrea Clavadetscher ¹	M 5	CHE 5	Graubunden 5	-
14.09. - 16.11.1997 ¹	-	Gustav Schneeli ¹	-	-	-	-
14.09. - 16.11.1997 ¹	Auf ein Bild hin ¹	Jakob Wäch ¹	Male 5	CHE 5	Glarus 5	-
14.09. - 16.11.1997 ¹	-	Vre Tschudi ¹	Female ¹	CHE ¹	Glarus ¹	-
24.01. - 13.04.1998 ¹	Koller „Gotthardpost“ meets Wielands „Letztes Leuchten“ and friends ¹	Various	Various	Various	Various	Various
		Rudolf Koller ¹	M 5	CHE 5	Zurich	-
		Hans Beat Wielands ¹	M 5	CHE 5	St. Gallen 5	-
28.02. - 03.05.1998 ¹	-	Eija-Liisa Ahtila ¹	F 12	FIN 12	Kanta-Häme 12	-
18.04. - 14.06.1998 ¹	Woodworld ¹	Olaf Breuning ¹	M 5	CHE 5	Schaffhausen 5	-
16.05. - 19.07.1998 ¹	-	Joseph Kosuth ¹	M 11	USA 11	Ohio 11	-
28.06. - 30.08.1998 ¹	In der Reihe: Die Kunst zu Sammeln, Schweizer Kunstsammlungen seit 1848 ¹	Marcus Casutt ¹	-	-	-	-
31.07. - 13.09.1998 ¹	-	Simone Ch. Wicki ¹	F 10	CHE10	Luzern 10	Visual artist
31.07. - 13.09.1998 ¹	Balsam ¹	Roland Herzog ¹	M 5	CHE 5	Schwyz 5	-
26.09. - 22.11.1998 ¹	-	Fabrice Hybert ¹	M 9	FRA 9	Vendée 9	-
05.12. - 10.01.1999 ¹	Fokus - Preis 1998 ¹	Patrick Rohner ¹	M 5	CHE 5	Schwyz 5	-
30.01. - 28.03.1999 ¹	-	Rico Nart ¹	-	-	-	-
30.01. - 28.02.1999 ¹	Screening Room ¹	Kristin Lucas ¹	F 17	USA 17	Iowa 17	-
30.01. - 28.03.1999 ¹	Until Nothing Can Reach Us ¹	Emmanuelle Antille ¹	F 5	CHE 5	Waadt 5	-
10.04. - 13.06.1999 ¹	-	Peter Doig ¹	M 16	GBR 16	Edinburgh 16	-
16.05. - 13.06.1999 ¹	Videowerke ¹	Suzy Spence ¹	F 15	USA 15	Massachusetts 15	-
27.06. - 29.08.1999 ¹	-	Liam Gillick ¹	M 14	GBR 14	South East England	-
27.06. - 29.08.1999 ¹	Viereck und Kosmos ¹	Roman Kurzmeier ¹	M 13	CHE 13	Luzern 13	-
10.09. - 21.11.1999 ¹	-	Paul Aymar Mourgue ¹	M 5	FRA 5	Geneva 5	-
10.09. - 21.11.1999 ¹	Guided By Voices ¹	Ugo Rondinone ¹	M 5	CHE 5	Schwyz 5	-
04.12. - 09.01.2000 ¹	Fokus - Preis 1999 ¹	Nicole Böniger ¹	F 5	CHE 5	St.Gallen 5	-
22.01. - 19.03.2000 ¹	-	T.J. Wilcox ¹	M 25	USA 25	Washington 25	-
22.01. - 19.03.2000 ¹	-	Markus Muntean ¹	M 24	AUT 24	Steiermark 24	-
		Adi Rosenblum ¹	F 24	ISR 24	Haifa 24	-
22.01. - 19.03.2000 ¹	-	Alfred Leuzinger ¹	M 5	CHE 5	St. Gallen 5	-
01.04. - 12.06.2000 ¹	Die pädagogische Wunderkammer und das Raritätenkabinett eines Schulmeisters ¹	Prof. Peter Jenny ¹	M 7	CHE 7	Glarus 7	-
01.04. - 12.06.2000 ¹	Tagessuppen Domestic Pairs Project (mit Keith Tyson) ¹	Various	Various	Various	Various	Various
		Urs Fischer ¹	M 5	CHE 5	Zurich 5	-
		Keith Tyson ¹	M 23	GBR 23	North West England	-
24.06. - 27.08.2000 ¹	Das linke Bein des Offiziers ¹	Daniel Roth ¹	M 22	DEU 22	Baden-Wuerttemberg	-
24.06. - 27.08.2000 ¹	bad bed bud pad bet pub ¹	Monica Bonvicini ¹	F 21	ITA 21	Veneto 21	-
09.09. - 19.11.2000 ¹	-	Joren de Rijke ¹	M 20	NLD 20	Zeeland 20	-
		Willem de Rooij ¹	M 19	NLD 19	Noord-Holland 19	-
09.09. - 19.11.2000 ¹	-	Peter Land ¹	M 18	DNK 18	Midtjylland 18	-
02.12. - 07.01.2001 ¹	Fokus - Preis 2000 ¹	Peter Kamm ¹	Male ⁵	CHE ⁵	Aargau ⁵	-
27.01. - 25.03.2001 ¹	Linolschnitte aus der Schenkung ¹	Lill Tschudi ¹	Female ¹	CHE ¹	Glarus ¹	-
07.04. - 10.06.2001 ¹	Fischbau ¹	Various	Various	Various	Various	Various
		Ingrid Käser ¹	Female ¹	CHE ¹	Glarus ¹	-
		Katrin Hotz ¹	Female ¹	CHE ¹	Glarus ¹	-
08.09. - 18.11.2001 ¹	Z Point ¹	Angela Bulloch ¹	Female ¹	CAN 26	Ontario 26	-
01.12. - 06.01.2002 ¹	Eile mit Weile oder langer Weg zur schönen Geschichte ¹	Vre Tschudi ¹	Female ¹	CHE ¹	Glarus ¹	-
01.12. - 06.01.2002 ¹	Fokus - Preis 2001 ¹	Peter Kamm ¹	Male ¹	CHE ¹	St. Gallen ¹	-
01.12. - 06.01.2002 ¹	Panoramen ¹	H. C. E. Von Der Linth ¹	Male ¹	-	-	-
07.07. - 01.09.2002 ¹	Imagineered Sculptures Study of Former Time (and Different Places) Somina ¹	Various	Various	Various	Various	Various
		Ruth Blesi ¹	Female ¹	CHE ¹	Zurich ¹	-
		Andrea Iten ¹	Female ¹	CHE ¹	Basel ¹	-
17.10. - 22.04.2003 ¹	Fischbau - Weisse Berge damit der Blick ins Leere stürzt ¹	Various	Various	Various	Various	Various
		Ingrid Käser ¹	Female ¹	CHE ¹	Glarus ¹	-
		Katrin Hotz ¹	Female ¹	CHE ¹	Glarus ¹	-

Date	Title	Artist	Gender	Nationality	State City	Age
01.12. - 05.01.2003 ¹	Fokus - Preis 2002 ¹	Tina Hauser ¹	Female ¹	CHE ¹	Glarus ¹	-
27.01. - 25.03.2001 ¹	A Huge Ever Growing Pulsating Brain That Rules From the Centre of the Ultraworld (the Orb, 1991) ¹	Various Vidya Gastaldon ¹ Jean-Michel Wicker ¹	Various - -	Various FRA ¹ FRA ¹	Various - -	Various - -
07.04. - 10.06.2001 ¹	-	Paul Pfeiffer ¹	Male ¹	USA ¹	Hawaii ¹	-
07.04. - 10.06.2001 ¹	-	Knut Asdam ¹	Male ¹	NOR ¹	New York ¹	-
23.06. - 18.11.2001 ¹	-	Cerith Wyn Evans ¹	Male ¹	GBR ¹	London ¹	-
27.01. - 01.04.2002 ¹	Trilogy ¹	Gillian Wearing ¹	Female ¹	GBR ¹	Birmingham ¹	-
21.04. - 23.06.2002 ¹	Space Is Deep ¹	Graeme Todd ¹	Male ¹	GBR ¹	East Lothian ¹	-
07.07. - 01.09.2002 ¹	Imagineered Sculptures Study of Former Time (and Different Places) Somina ¹	Various Hellen Van Meene ¹ David Chieppo	Various Female ¹ Male ¹	Various NLD ¹ USA ¹	Various Alkmaar ¹ Zurich ? ¹	Various - -
17.10. - 22.04.2003 ¹	Fischbau - Weisse Berge damit der Blick ins Leere stürzt ¹	Various Ingrid Käser ¹ Katrin Hotz ¹	Various Female ¹ Female ¹	Various CHE ¹ CHE ¹	Various Glarus ¹ Glarus ¹	Various - -
01.12. - 05.01.2003 ¹	Fokus - Preis 2002 ¹	Tina Hauser ¹	Female ¹	CHE ¹	Glarus ¹	-
29.11. - 11.01.2004 ¹	Fokus - Preis 2003 ¹	Rahel Opprecht ¹	Female ¹	CHE ²⁷	Glarus ²⁷	33 ²⁷
04.11. - 30.04.2004 ¹	Durch die Welt streifen - New Imagineered Sculptures ¹	Ruth Blesi ¹	Female ⁵	CHE ⁵	Glarus ⁵	35 ⁵
14.09. - 16.11.2003 ¹	You Can't Stay in the 80s Wearing Cowboy Boots While the Whole World Progresses ¹	Julika Rudeliu ¹	Female ²⁸	DEU ²⁸	Köln ²⁸	35 ²⁸
14.09. - 16.11.2003 ¹	Thank You Glarus ¹	Carl Andre ¹	Male ¹	USA ¹	New York ¹	68 ¹
14.09. - 16.11.2003 ¹	Treasures and Adventures. Musik für eine Ausstellung ¹	Manuel Stagars ¹	Male ¹	CHE ¹	Zurich ¹	29 ¹
29.06. - 24.08.2003 ¹	Fink Forward. Edition Fink: the Collection/Connection ¹	Various Valentin Carron ¹ Jonathan Delachaux ¹ Cooky Gordon ¹ Markus Müller ¹ Mai-Thu Perret ¹ Daniel Schibl ¹ Stefan A Wengen ¹	Various Male ⁵ Male ⁵ Female ¹ Male ¹ Female ⁵ Male ⁵ Male ⁵	Various CHE ⁵ CHE ⁵ USA ¹ CHE ¹ CHE ⁵ CHE ⁵ CHE ⁵	Various Wallis ⁵ Neuenburg ⁵ California ¹ Basel ¹ Geneva ⁵ Aargau ⁵ Basel ⁵	Various 26 ⁵ 27 ⁵ 30 ¹ 33 ¹ 27 ⁵ 40 ⁵ 39 ⁵
29.06. - 24.08.2003 ¹	Greta Leuzinger ¹	Greta Leuzinger ¹	Female ¹	CHE ¹	Glarus ¹	91 ¹
18.04. - 05.06.2003 ¹	Supercritical Fluids ¹	Hanspeter Hofmann ¹	Male ⁵	CHE ⁵	Glarus ⁵	43 ⁵
18.04. - 15.06.2003 ¹	Think Thingamajig and Other Things ¹	Tom O'sullivan ¹ Joanne Tatham ¹	Male ¹ Female ¹	GBE ¹ GBE ¹	Norwich ¹ West Yorkshire ¹	36 ¹ 32 ¹
18.04. - 15.06.2003 ¹	Le temple de l'extase ¹	Frédéric Post ¹	Male ⁵	CHE ⁵	Geneva ⁵	28 ⁵
26.01. - 30.03.2003 ¹	How High Can You Fly ¹	Various Vincent Kohler ¹ Sven Kroner ¹ Bernhard Martin ¹ Antonietta Peeters ¹ Jean-Frederic Schnyder ¹ Jim Shaw ¹ Ge-Karel Van Der Sterren ¹	Various Male ⁵ Male ²⁹ Male ³⁰ Female ¹ Male ⁵ Male ³¹ Male ³²	Various CHE ⁵ DEU ²⁹ DEU ³⁰ NLD ¹ CHE ⁵ USA ³¹ NLD ³²	Various Waadt ⁵ Baveria ²⁹ Lower Saxony ³⁰ Nordholland ¹ Basel ⁵ Michigan ³¹ Groningen ³²	Various 26 ⁵ 30 ²⁹ 37 ³⁰ 36 ¹ 58 ⁵ 51 ³¹ 34 ³²
07.12. - 16.01.2005 ¹	Fokus-Preis 2004 ¹	Daniela Zimmermann ¹	Female ¹	CHE ¹	Glarus ¹	27 ¹
22.08. - 14.11.2004 ¹	There's no Other World out There... There's Just This One ¹	Daniel Robert Hunziker ¹	Male ⁵	CHE ⁵	St.Gallen ⁵	39 ⁵
16.05. - 01.08.2004 ¹	Hot Lunch ¹	Various Philippe Decrauzat ¹ Pierre Vadi ¹	Various Male ⁵ Male ⁵	Various CHE ⁵ CHE ⁵	Various Waadt ⁵ Wallis ⁵	Various 30 ⁵ 38 ⁵
16.05. - 01.08.2004 ¹	Toucanart ¹	Bettina Graf ¹	Female ⁵	CHE ⁵	Zurich ⁵	27 ⁵
01.02. - 02.05.2004 ¹	O ¹	Jim Shaw ¹	Male ³¹	USA ³¹	Michigan ³¹	52 ³¹
04.12. - 15.01.2006 ¹	Fokus-Preis 2005 ¹	Susanne Hauser ¹	Female ¹	CHE ⁵	Glarus ⁵	59 ⁵
11.09. - 20.11.2005 ¹	Recreating the Case ¹	Various Alexandra Hopf ¹ Isabelle Krieg ¹ Fernando Ortega ¹ Peter Regli ¹ Julika Rudelius ¹ Shahzad Group ¹ Manuel Krebs ¹ Shirana Shahbazi ¹ Tirdad Zolghadr ¹	Various Female ¹ Female ⁵ Male ¹ Male ⁵ Female ¹ Various Male ³⁴ Female ³⁴ Male ³⁵	Various DEU ³³ CHE ⁵ MEX ⁵ CHE ⁵ DEU ¹ Various CHE ³⁴ IRN ³⁴ IRN ³⁵	Various Hessen ³³ Fribourg ⁵ - Graubunden ⁵ Köln ¹ Various Bern ³⁴ Tehran ³⁴ Theran ³⁵	Various 37 ¹ 34 ¹ 34 ¹ 46 ⁵ 37 ¹ Various 35 ³⁴ 31 ³⁴ 32 ³⁵
22.05. - 21.08.2005 ¹	Mirage of Loose Change ¹	Gary Webb ¹	Male ¹	GBR ¹	Dorset ¹	32 ¹
05.02. - 01.05.2005 ¹	Loin loin loin ¹	Annelise Coste ¹	Female ⁵	FRA ⁵	Marseille ⁵	32 ⁵
03.12. - 14.01.2007 ¹	Fokus-Preis 2006 ¹	Matthias Käser ¹	Male ¹	CHE ¹	Zurich ¹	28 ¹
03.09. - 19.11.2006 ¹	Some Sin for Nothing ¹	Tobias Zielony ¹	Male ¹	DEU ¹	Wuppertal ¹	33 ¹
03.09.-19.09.2006 ¹	Quelquepart II ¹	Various Ingrid Wildi ¹ Mauricio Gajardo ¹	Various Female ¹ Male ¹	Various CHL ¹ CHL ¹	Various SCL ¹ La Cerena ¹	Various 43 ¹ 37 ¹
28.05. - 13.08.2006 ¹	Most und Karfunkel ¹	Rolf Graf ¹	Male ⁵	CHE ⁵	Appenzell ⁵	37 ¹
28.05. - 13.08.2006 ¹	Oben halb offen ¹	Vaclav Pozarek ¹	Male ⁵	SVK ⁵	Budejovice ¹	66 ¹
05.02. - 07.05.2006 ¹	Agatenplatten ¹	Markus Müller ¹	Male ⁵	CHE ⁵	Appenzell ⁵	36 ⁵
09.09. - 18.11.2007 ¹	Ästhetik und Langeweile ¹	Peter Piller ¹	Male ¹	DEU ¹	Hessen ³⁶	39 ¹

Date	Title	Artist	Gender	Nationality	State City	Age
27.05. - 19.08.2007 1	Photographers in Conflict 1	Various	Various	Various	Various	Various
		Goran Galić 1	Male 5	CHE 5	Luzern 5	30 5
		Gian-Reto Gredig 1	Male 5	CHE 5	Graubunden 5	31 5
27.05. - 19.08.2007 1	Excuse Me Brother 1	Jeanne Faust 1	Female 37	DEU 37	Wiesbaden 37	39 37
04.02. - 06.05.2007 1	School of Flowers - Come Let Us Smile a Little Space/Upon Fond Nature's Morbid Grace 1	Various	Various	Various	Various	Various
		Sebastian Hammwöhner 1	Male 38	DEU 38	Frechen 38	33 38
		Dani Jakob 1	Female 39	DEU 39	Freiburg i./Br 39	34 39
		Gabriel Vormstein 1	Male 40	DEU 40	Konstanz 40	33 40
04.02. - 06.05.2007 1	Anche se non posso focalizzarti - sie nel mio sguardo, erster Teil: Eine Untersuchung der Wahrscheinlichkeit von Begegnung im urbanen Raum 1	Various	Various	Various	Various	Various
		Petra Elena Köhle 1	Female 5	AUT 5	Zurich 5	30 5
		Nicolas Petit-Outhenin 1	Male 5	CHE 5	Fribourg 5	30 5
04.02. - 15.04.2007 1	The Defeated Life Restored 1	David Thorpe 1	Male 41	GBR 41	London 41	35 41
27.01. - 25.03.2001 1	A Huge Ever Growing Pulsating Brain That Rules From the Centre of the Ultraworld (the Orb, 1991) 1	Various	Various	Various	Various	Various
		Vidya Gastaldon 1	-	FRA 1	-	-
		Jean-Michel Wicker 1	-	FRA 1	-	-
07.04. - 10.06.2001 1	-	Paul Pfeiffer 1	Male 1	USA 1	Hawaii 1	-
07.04. - 10.06.2001 1	-	Knut Asdam 1	Male 1	NOR 1	New York 1	-
23.06. - 18.11.2001 1	-	Cerith Wyn Evans 1	Male 1	GBR 1	London 1	-
27.01. - 01.04.2002 1	Trilogy 1	Gillian Wearing 1	Female 1	GBR 1	Birmingham 1	-
21.04. - 23.06.2002 1	Space Is Deep 1	Graeme Todd 1	Male 1	GBR 1	East Lothian 1	-
07.07. - 01.09.2002 1	Imagineered Sculptures Study of Former Time (and Different Places) Somina 1	Various	Various	Various	Various	Various
		Hellen Van Meene 1	Female 1	NLD 1	Alkmaar 1	-
		David Chieppo	Male 1	USA 1	Zurich ? 1	-
07.12. - 25.01.2009 1	Fokus-Preis 2008 1	Irene Schubiger 1	Female 5	CHE 5	Glarus 5	60 5
21.06. - 07.09.2008 1	Mind the Gap 1	Various	Various	Various	Various	Various
		Christoph Girardet 1	Male 42	DEU 42	Niedersachsen 42	42 42
		Matthias Müller 1	Male 43	DEU 43	Bielefeld 43	47 43
		William Hunt 1	Male 44	GBR 44	London 44	31 44
		Nils Nova 1	Male 5	SLV 5	El Salvador 5	40 5
		Adrian Paci 1	Male 45	ALB 45	Shkodra 45	39 45
		Martina Sauter 1	Female 46	DEU 46	Konstanz 46	34 46
		Philip Wiegard 1	Male 47	DEU 47	Schwetzingen 47	31 47
		Raphael Hefti 1	Male 5	CHE 5	Neuburg 5	30 5
		Katrin Hotz 1	Female 5	CHE 5	Glarus 5	33 5
		Maja Bajevic 1	Female 48	BIH 48	Sarajevo 48	42 48
		02.03. - 01.06.2008 1	Langblitzpulver 1	Kilian Rüthemann 1	Male 5	CHE 5
06.12. - 17.01.2010 1	Fokus-Preis 2009 1	Davide Cascio 1	Male 5	CHE 5	Tessin 5	33 5
06.09. - 22.11.2009 1	Import Export 1	Various	Various	Various	Various	Various
17.05. - 16.08.2009 1	Sooner Rather Than Later 1	Nina Fischer 1	Female 49	DEU 49	Niedersachsen 49	44 49
15.02. - 03.05.2009 1	A Portrait of the Man as a Building 1	Maroan el Sani 1	Male 49	DEU 49	Duisburg 49	43 49
15.02. - 03.05.2009 1	The Beauty of the Imperfect, Impermanent and Incomplete 1	Various	Various	Various	Various	Various
		Ingrid Käser 1	Female 5	CHE 5	Zurich 5	34 5
		Alexandra Bachzetsis 1	Female 5	CHE 5	Zurich 5	36 5
05.12. - 17.01.2011 1	Fokus-Preis 2010 1	Johanna Billing 1	Female 50	SWE 50	Jönköping 50	37 50
05.09. - 21.11.2010 1	Play 1	Various	Various	Various	Various	Various
05.09. - 21.11.2010 1	I'm Lost Without Your Rhythm 1	Falke Pisano 1	Female 51	NLD 51	Amsterdam 51	32 52
05.09. - 21.11.2010 1	Dynamo 1	Ana Roldan 1	Female 5	MEX 5	Mexico City 5	33 5
		Various	Various	Various	Various	Various
		Mathis Altmann 1	Male 52	DEU 52	Baveria 52	23 52
		Annette Amberg 1	Female 53	CHE 53	Bern 53	32 53
		Radio Arthur 1	-	-	-	-
		Kim Seob Boninsegni 1	Male 54	CHE 54	Seoul 54	36 54
		Vittorio Brodmann 1	Male 55	CHE 55	Basel 55	23 55
		Emilie Ding 1	Female 5	CHE 5	Fribourg 5	29 5
		Edgars Gluhovs 1	Male 56	LVA 56	Riga 56	30 56
		Dagmar Heppner 1	Female 5	DEU 5	Hamburg 5	33 5
		Cédric Eisenring 1	Male 5	CHE 5	St.Gallen 5	27 5
		Thomas Julier 1	Male 57	CHE 57	Wallis 57	27 57
		Tobias Kaspar 1	Male 56	CHE 56	Basle 56	26 56
		Emil Michael Klein 1	Male 5	CHE 5	Bavaria 5	28 5
		Balthazar Lovay 1	Male 58	-	-	-
		Tobias Madison 1	Male 5	CHE 5	Basel 5	25 5
		Kaspar Müller 1	Male 5	CHE 5	Schaffhausen 5	27 5
		Guillaume Pilet 1	Male 5	CHE 5	Waadt 5	26 5
		Provence 1	-	-	-	-
		Marta Riniker-Radich 1	Female 5	CHE 5	Bern 5	28 5
		Pamela Rosenkranz 1	Female 5	CHE 5	Uri 5	31 5
Emanuel Rossetti 1	Male 59	CHE 59	Basel 59	23 59		
Valentina Stieger 1	Female 60	CHE 60	St.Gallen 60	30 60		
Hannah Weinberger 1	Female 61	DEU 61	Fildernstadt 61	22 61		

Date	Title	Artist	Gender	Nationality	State City	Age		
07.02. - 02.05.2010	Performative Attitudes 1	Various	Various	Various	Various	Various		
		Stefan Burger 1	Male 5	DEU 5	Müllheim 5	33 5		
		Florian Germann 1	Male 5	CHE 5	Thurgau 5	32 5		
		Hanna Schwarz 1	Female 1	DEU 62	Stuttgart 62	35 62		
		Seb Patane 1	Male 63	ITA 63	Catania 63	40 1		
		Navid Nuur 1	Male 64	IRN 64	Teheran 64	34 64		
		Nina Canell 1	Female 65	SWE 65	Växjö 65	31 65		
		Robin Watkins 1	Male 66	SWE 66	Stockholm 66	30 66		
		Nina Beier 1	Female 67	DNK 67	Aarhus 67	35 67		
		Marie Lund 1	Female 68	DNK 68	Copenhagen 68	34 68		
		13.11. - 22.01.2012	Everything but Arms 1	Annette Amberg 1	Female 53	CHE 53	Bern 53	33 53
		13.11. - 22.01.2012	Topics Values 1	Neil Beloufa 1	Male 69	FRA 69	Paris 69	26 69
		21.08. - 30.10.2011	Resorts 1	Vanessa Safavi 1	Female 5	CHE 5	Waadt 5	31 5
15.05. - 07.08.2011	(RE)CONSTRUCTED 1	Various	Various	Various	Various	Various		
		Sarah Burger 1	Female 5	CHE 5	Glarus 5	29 5		
		Christoph Draeger 1	Male 5	CHE 5	Zurich 5	46 5		
		Cyprien Gaillard 1	Male 70	FRA 70	Paris 70	31 70		
		Marina Hauser 1	Female 71	CHE 71	Glarus 71	42 71		
		Susanne Hauser 1	Female 5	CHE 5	Glarus 5	65 5		
		Nicole Hoesli 1	Female 5	CHE 5	Aargau 5	31 5		
		Sofia Hultén 1	Female 72	SWE 72	Stockholm 72	39 72		
		Janet Cardiff 1	Female 73	CAN 73	Ontario 73	54 73		
		George Bures Miller 1	Male 74	CAN 74	Alberta 74	51 74		
		Siro A. Micheroli 1	Male 75	CHE 75	Glarus 75	38 75		
		Loredana Sperini 1	Female 5	ITA 5	St.Gallen 5	41 5		
		06.02. - 01.05.2011	Livingroom Exotica 1	Various	Various	Various	Various	Various
				Kader Attia 1	Male 76	FRA 76	Paris 76	41 76
				Isabelle Cornaro 1	Female 77	FRA 77	-	37 77
Lili Reynaud Dewar 1	Female 78			FRA 78	La Rochelle 78	36 78		
Rashid Johnson 1	Male 79			USA 79	Illinois 79	34 79		
Fabian Marti 1	Male 5			CHE 5	Fribourg 5	32 5		
Vanessa Safavi 1	Female 5			CHE 5	Waadt 5	31 5		
Costa Vece 1	Male 5			ITA 5	Appenzell 5	42 5		
06.02. - 01.05.2011	Coming Together 1	Daniel Silver 1	Male 80	GBR 80	London 80	39 80		
02.12. - 20.01.2013	Fokus-Preis 2012 1	Claudio Zopfi 1	Male 81	CHE 81	Glarus 81	39 81		
09.09. - 18.11.2012	The Exoteric Wall 1	Various	Various	Various	Various	Various		
		Louise Hervé 1	Female 1	FRA 1	Paris 1	31 1		
		Chloé Maillot 1	Female 1	FRA 1	Paris 1	31 1		
09.09. - 18.11.2012	Unter 30 VIII - Junge Schweizer Kunst 1	Various	Various	Various	Various	Various		
		Mirko Baselgia 1	Male 5	CHE 5	Graubunden 5	30 5		
		Fabian Chiquet 1	Male 5	CHE 5	Basel 5	27 5		
		Claudia Comte 1	Female 5	CHE 5	Waadt 5	29 5		
		Tudi Deligne 1	Male 1	CHE 1	-	25 1		
		Anne-Sophie Estoppey 1	Female 1	CHE 82	-	25 1		
		Jean-Philippe Volonter 1	Male 1	-	-	27 1		
		Dominique Koch 1	Female 5	CHE 5	Luzern 5	29 5		
		Elisa Larvego 1	Female 5	CHE 5	Geneva 5	28 5		
		Michael Meier 1	Male 5	AUT 5	Vienna 5	32 5		
		Christoph Franz 1	Male 5	DEU 5	Singen 5	30 5		
		Augustin Rebetez 1	Male 5	CHE 5	Jura 5	26 5		
		Anne RoCHAT 1	Female 5	CHE 5	Waadt 5	30 5		
		17.05. - 16.08.2015	White Noise 1	Various	Various	Various	Various	Various
				Sophie Bueno-Boutellier 1	Female 91	FRA 91	Toulouse 91	41 91
Manuel Burgener 1	Male 5			CHE 5	Bern 5	37 5		
Nina Canell 1	Female 65			SWE 65	Växjö 65	36 65		
Robin Watkins 1	Male 66			SWE 66	Stockholm 66	35 66		
Cevdet Erek 1	Male 92			TUR 92	Istanbul 92	41 92		
Judith Fegerl 1	Female 93			AUT 93	Vienna 93	38 93		
Bruno Jakob 1	Male 5			CHE 5	Bern 5	61 5		
Judith Kakon 1	Female 94			CHE 94	Basel 94	27 94		
08.02. - 03.05.2015	Fit for Purpose 1			Various	Various	Various	Various	Various
		Ruth Buchanan 1	Female 95	NZL 95	Aotearoa 95	35 95		
		Adam Cruces 1	Male 5	USA 5	Houston 5	30 5		
		Gina Folly 1	Female 96	CHE 96	Zurich 96	32 96		
		Karin Hueber 1	Female 5	CHE 5	Basel 5	38 5		
		Marlie Mul 1	Female 97	NLD 97	Utrecht 97	35 97		
		Simon Dybbroe Møller 1	Male 98	DNK 98	Aarhus 98	39 98		
		Magali Reus 1	Female 99	NLD 99	The Hague 99	34 99		
		Valentina Stieger 1	Female 60	CHE 60	St.Gallen 60	35 60		
		Haegue Yang 1	Female 100	KOR 100	Seoul 100	44 100		
		11.12. - 29.01.2017	Super Cool X-1000 1	Urs August Steiner 1	Male 101	CHE 101	Zurich 101	36 101
		04.09. - 27.11.2016	Hunter in the Void 1	Thomas Julier 1	Male 57	CHE 57	Wallis 57	33 57
22.05. - 21.08.2016	Every Cell Is a Bell 1	Shana Moulton 1	Female 102	USA 102	California 102	40 102		

Date	Title	Artist	Gender	Nationality	State City	Age		
26.04. - 01.05.2016	Public Collection of Modern Art 1	Various	Various	Various	Various	Various		
		Alexandra Pirici 1	Female 103	ROU 103	Bucharest 103	34 103		
		Manuel Pelmuş 1	Male 104	ROU 104	Bucharest 104	42 104		
14.02. - 08.05.2016	Unruly Relations 1	Various	Various	Various	Various	Various		
		Jay Chung 1	Male 105	USA 105	Wisconsin 105	40 105		
		Q Takeki Maeda 1	-	JPN 106	Nagoya 106	39 106		
		Selina Grüter 1	Female 107	CHE 107	-	25 107		
		Michèle Graf 1	Female 1	CHE 1	-	29 1		
		Birgit Megerle 1	Female 1	DEU 1	Geisingen 1	41 1		
		Stuart Middleton 1	Male 1	GBR 1	Crewe 1	29 1		
		Stefan Tcherepnin 1	Male 1	USA 1	Massachusetts 1	39 1		
		Ramaya Tegegne 1	Female 1	CHE 1	Geneva 1	31 1		
		Jan Vorisek 1	Male 1	CHE 1	Basel 1	29 1		
		03.12. - 28.01.2018	Fokus-Preis - Kabinett der Du 1	Lisa Eikrann 1	Female 1	NOR 1	Darmmen 1	34 1
28.05. - 30.07.2017	The Painted Veil 1	Birgit Megerle 1	Female 1	DEU 1	Geisingen 1	42 1		
12.03. - 14.05.2017	In the Museum Trilogy 1	Mathis Gasser 1	Male 5	CHE 5	Zurich 5	33 5		
12.03. - 14.05.2017	Popular Unrest 1	Melanie Gilligan 1	Female 1	CAN 105	Toronto 105	38 105		
12.02. - 26.02.2017	Plattform17 – A Winter School 1	Various	Various	Various	Various	Various		
		Mohamed Abdelkarim 1	Male 106	EGY 106	Al-Minya 106	34 106		
		Andriu Deplazes 1	Male 106	CHE 106	Zurich 106	24 106		
		Oliver Falk 1	Male 106	CHE 106	Basel 106	35 106		
		Hector Gachet 1	Male 106	FRA 106	Paris 106	25 106		
		Martina Mächler 1	Female 106	CHE 106	Schwyz 106	26 106		
		Lucia Martinez 1	Female 106	CHE 106	Geneva 106	23 106		
		Sveta Mordovskaya 1	Female 106	RUS 106	Ulan-Ude 106	28 106		
		Gilles Rotzetter 1	Male 106	CHE 106	Geneva 106	39 106		
		Konstantinos Sotiriou 1	Male 106	GRC 106	Athen 106	37 106		
		Valentina Triet 1	Female 106	CHE 106	Zurich 106	26 106		
		Gaia Vincensini 1	Female 106	CHE 106	Geneva 106	25 106		
		Luc Ming Yan 1	Male 106	FRA 106	Dijon 106	23 106		
		23.09. - 11.11.2018	Kiefer Hablitzel Göhner Kunstpreis 2018 1	Various	Various	Various	Various	Various
				Martina Mächler 1	X 5	CHE 5	Schwyz 5	26 5
				Marie Matusz 1	Female 1	FRA 1	Toulouse 1	23 1
				Valentina Minnig 1	Female 1	CHE 1	Graubunden 1	26 1
Mia Sanchez 1	Female 1			ESP	Sevillia 1	29 1		
Dorian Sari 1	Male 5			TUR 5	Izmir 5	28 5		
Rafal Skoczek 1	Male 1			POL 1	Bystrzyca 1	28 1		
Axelle Stiefel 1	Female 5			CHE 5	New York 5	29 5		
Bonnie Camplin 1	Female 107			GBR 107	London 107	47 107		
Riniker-Radich 1	Female 5			CHE 5	Bern 5	35 5		
27.10. - 01.01.2020	The Premise of a Better Life 1	Sam Pulitzer 1	Male 108	USA 108	Fremont 108	35 108		
30.06. - 10.11.2019	PAX 1	Bea Schlingelhoff 1	Female 109	DEU 109	-	48 109		
13.12. - 14.03.2021	Künstlerbücher 1	Klaus Born 1	Male 5	CHE 5	Glarus 5	75 5		
05.09. - 29.11.2020	Im Volksgarten 1	Various	Various	Various	Various	Various		
		Olivia Ali 1	Female 1	CHE 1	Zurich 1	35 1		
		Tobias Kaspar 1	Male 5	CHE 5	Basel 5	36 1		
		Rachal Bradley 1	Female 1	GBR 1	Blackpool 1	41 1		
		Trisha Donnelly 1	Female 1	USA 1	California 1	46 1		
		Richard Frater 1	Male 1	NZL 1	Wellington 1	36 1		
		Carissa Rodriguez 1	Female 1	USA 1	New York 1	50 1		
		Julia Scher 1	Female 1	USA 1	California 1	66 1		
		Bea Schlingelhoff 1	Female 109	DEU 109	-	49 109		
		Jan Vorisek 1	Male 1	CHE 1	Basel 1	33 1		
		15.03. - 23.08.2020	Collapse Poem 1	Various	Various	Various	Various	Various
				Martin Stütze 1	Male 5	CHE 5	Aargau 5	61 5
				Fridolin Walcher 1	Male 5	CHE 5	Glarus 5	69 5
12.01. - 01.03.2020	Des Gletschers Kern 1	Karin Reichmuth 1	Female 5	CHE 5	St.Gallen 5	42 5		
		Elliot Reed 1	Male 1	USA 1	-	29 1		
		Bri Williams 1	Female 110	USA 110	California 110	28 110		
05.09. - 28.11.2021	Rythem 1	Jade Kuriki Olivo 1	Female 111	USA 111	Texas 111	32 111		
05.09. - 28.11.2021	Angel Abra 1	Silvia Kolbowski 1	Female 112	ARG 112	Buenos Aires 112	69 112		
06.06. - 22.08.2021	Puppies Puppies 1	Laura Langer 1	Female 113	ARG 113	Buenos Aires 113	36 113		
04.09. - 27.11.2022	Who will save us? 1	Daphne Ahlers 1	Female 114	DEU 114	Hamburg 114	36 114		
04.09. - 27.11.2022	Headlines 1	Nicole Wermers 1	Female 115	DEU 115	Emsdetten 115	51 115		
29.05. - 21.08.2022	Die Würflerin 1	Romane Chabrol 1	Female 116	FRA 116	-	27 116		
29.05. - 21.08.2022	Reclining Fanmail 1	Hélène Fauquet 1	Female 117	FRA 117	Saint-Saulve 117	35 117		
20.02. - 15.05.2022	L'Étang de rien 1	Flora Klein 1	Female 118	CHE 118	Bern 118	35 118		
09.07. - 19.11.2023	Phenomena 1	Sophie Gogl 1	Female 119	AUT 119	Kitzbuhel 119	31 119		
09.07. - 19.11.2023	Heat 1							
26.02. - 25.06.2023	Die knusprige Nichte 1							

- 1 <https://kunsthausglarus.ch/de/ausstellungen/archiv/>
- 2 https://en.wikipedia.org/wiki/Helen_Chadwick#cite_note-Swell-1
- 3 <http://www.andreaiten.ch/Lebenslauf.html>
- 4 <https://www.carmenekreis.ch/biografie/biografie.html>
- 5 https://recherche.sik-isea.ch/en/everything/in/sikart/actor/list?ui.featured=cms:news_40572335-6f57-47f4-b830-bab0b48cfd87
- 6 https://www.malyschilliger.ch/pdf/KS_VM_Portfolio_d.pdf
- 7 [https://de.wikipedia.org/wiki/Peter_Jenny_\(Architekt\)](https://de.wikipedia.org/wiki/Peter_Jenny_(Architekt))
- 8 https://de.wikipedia.org/wiki/Zoe_Leonard
- 9 https://en.wikipedia.org/wiki/Fabrice_Hybert
- 10 https://l-wiki.ch/Simone_Wicki
- 11 https://de.wikipedia.org/wiki/Joseph_Kosuth
- 12 https://de.wikipedia.org/wiki/Eija-Liisa_Ahtila
- 13 <https://www.atelier-amen.ch/de/info/roman-kurzmeyer-biographie>
- 14 https://de.wikipedia.org/wiki/Liam_Gillick
- 15 <https://www.vermontartscouncil.org/grants/find-a-grant/artists/creation/peoples-choice-award/suzy-spence/>
- 16 https://de.wikipedia.org/wiki/Peter_Doig
- 17 https://en.wikipedia.org/wiki/Kristin_Lucas
- 18 <https://de.wikipedia.org/wiki/Aarhus>
- 19 https://de.wikipedia.org/wiki/Willem_de_Rooij
- 20 https://de.wikipedia.org/wiki/Jeroen_de_Rijke
- 21 https://de.wikipedia.org/wiki/Monica_Bonvicini
- 22 [https://de.wikipedia.org/wiki/Daniel_Roth_\(Künstler\)](https://de.wikipedia.org/wiki/Daniel_Roth_(Künstler))
- 23 https://en.wikipedia.org/wiki/Keith_Tyson
- 24 <https://de.wikipedia.org/wiki/Muntean/Rosenblum>
- 25 <https://www.sadiecoles.com/artists/47-tj-wilcox/>
- 26 https://de.wikipedia.org/wiki/Angela_Bulloch
- 27 <https://www.glarus24.ch/artikel/glueckssachen-im-gartenfluegel-ziegelbruecke-2417125/>
- 28 https://en.wikipedia.org/wiki/Julika_Rudelius
- 29 https://de.wikipedia.org/wiki/Sven_Kroner
- 30 [https://de.wikipedia.org/wiki/Bernhard_Martin_\(K%C3%BCnstler\)](https://de.wikipedia.org/wiki/Bernhard_Martin_(K%C3%BCnstler))
- 31 <https://gagosian.com/artists/jim-shaw/>
- 32 <https://www.rogallery.com/artists/ge-karel-van-der-sterren/cow-in-field/?variant=31383582244929>
- 33 <https://lrrh.de/artist/alexandra-hopf/>
- 34 <https://m-restaurantgroup.com/shirana-manu/>
- 35 https://en.wikipedia.org/wiki/Tirdad_Zolghadr
- 36 https://de.wikipedia.org/wiki/Peter_Piller
- 37 https://de.wikipedia.org/wiki/Jeanne_Faust
- 38 <http://www.artnet.de/k%C3%BCnstler/sebastian-hammw%C3%B6hner/biografie>
- 39 <https://www.nicolaskrupp.com/artists/dani-jakob>
- 40 <http://gabrielvormstein.com/index.php/cv/>
- 41 https://de.wikipedia.org/wiki/David_Thorpe
- 42 https://de.wikipedia.org/wiki/Christoph_Girardet
- 43 [https://de.wikipedia.org/wiki/Matthias_M%C3%BCller_\(Filmemacher\)](https://de.wikipedia.org/wiki/Matthias_M%C3%BCller_(Filmemacher))
- 44 <https://nicolausschafhausen.com/william-hunt-tempting-fate-swimming-alone/>
- 45 https://de.wikipedia.org/wiki/Adrian_Paci
- 46 <https://www.martinasauter.de/vita>
- 47 <https://artfacts.net/artist/philip-wiegard/26367>
- 48 https://de.wikipedia.org/wiki/Maja_Bajevi%C4%87
- 49 <https://www.fischerelsani.net/cv/>
- 50 <http://johannabilling.com/biography/>
- 51 <https://kunst.mobiliar.ch/mathis-altmann>
- 52 <https://artfacts.net/artist/annette-amberg/66883>
- 53 https://fr.wikipedia.org/wiki/Kim_Seob_Boninsegni
- 54 <https://galerie.gregorstaiger.com/Vittorio-Brodmann-Biography>
- 55 <https://kim.lv/en/edgars-gluhovs-luomo-vague/>
- 56 <https://kim.lv/en/edgars-gluhovs-luomo-vague/>
- 57 <https://kunst.mobiliar.ch/thomas-julier>
- 58 <https://artfacts.net/artist/balthazar-lovay/129966>
- 59 <https://karmainternational.ch/artists/48-emanuel-rossetti/>
- 60 <https://www.stampa-galerie.ch/k%C3%BCnstler/S/Valentina-STIEGER/72>
- 61 <https://www.kunstmuseum-so.ch/de/ausstellungen/453-hannah-weinberger>
- 62 <https://nagel-draxler.de/artist/hanna-schwarz/>
- 63 <https://sepatane.com/bio>
- 64 <https://www.mutualart.com/Artist/Navid-Nuur/E7F9703D1E2A209A/Biography>
- 65 https://de.wikipedia.org/wiki/Nina_Canell
- 66 <https://kunstaspekte.art/person/robin-watkins>
- 67 <https://www.biennaleofsydney.art/participants/nina-beier/>
- 68 <https://www.kunstmuseumsg.ch/marie-lund>
- 69 <https://www.maxgoelitz.com/artists/41-neil-beloufa/>
- 70 https://de.wikipedia.org/wiki/Cyprien_Gaillard
- 71 https://www.glarneragenda.ch/de/kulturschaffende/glarus/marina-hauser_AD7TUQe
- 72 https://de.wikipedia.org/wiki/Sofia_Hult%C3%A9n
- 73 https://de.wikipedia.org/wiki/Janet_Cardiff
- 74 https://de.wikipedia.org/wiki/George_Bures_Miller
- 75 <https://www.suedostschweiz.ch/zeitung/siro-antonio-micheroi>
- 76 https://de.wikipedia.org/wiki/Kader_Attia
- 77 <https://isabellecornaro.com/biography/>
- 78 https://de.wikipedia.org/wiki/Lili_Reynaud-Dewar
- 79 https://en.wikipedia.org/wiki/Rashid_Johnson
- 80 https://en.wikipedia.org/wiki/Daniel_Silver
- 81 https://www.claudio.com/wp-content/uploads/2012/10/claudio_zopfi_portfolio_2012.pdf
- 82 <https://www.emuseum.ch/de/people/85977/annesophie-estoppey>
- 83 <http://www.andrewkreps.com/artists/joao-maria-gusmao>
- 84 https://www.sfmoma.org/artist/Pedro_Paiva/
- 85 https://de.wikipedia.org/wiki/Haris_Epaminonda
- 86 https://deutscheoperberlin.de/en_EN/ensemble/165960
- 87 <https://www.dirosaart.org/2015/06/robert-kinmont/>
- 88 https://de.wikipedia.org/wiki/Sa%C3%A2dane_Afif
- 89 <https://www.emuseum.ch/en/people/78734/lorenzo-bernet;jsessionid=68BE1B6AF2F9E9D43DD3FA2B43A84AED/objects>
- 90 <https://www.anjabraun.ch/info/>
- 91 <http://www.trianglefrance.org/en/residences/sophie-bueno-boutellier/>
- 92 https://de.wikipedia.org/wiki/Cevdet_Erek
- 93 <https://www.galeriewinter.at/en/artists/judith-fegerl/biography/>
- 94 <https://judithkaton.com/>
- 95 https://en.wikipedia.org/wiki/Ruth_Buchanan
- 96 <https://www.bazonline.ch/das-licht-der-welt-und-doppelbelichtete-schafe-563211277097>
- 97 <https://www.wiels.org/en/residencies/marie-mul>
- 98 https://en.wikipedia.org/wiki/Simon_Dybbroe_M%C3%B8ller
- 99 <https://magalireus.com/about#bibliography>
- 100 https://de.wikipedia.org/wiki/Haegue_Yang
- 101 <https://www.ursauguststeiner.com/>
- 102 <https://art21.org/artist/shana-moulton/>
- 103 https://de.wikipedia.org/wiki/Alexandra_Pirici
- 104 <https://khio.no/en/staff/manuel-pelmus>
- 105 https://de.wikipedia.org/wiki/Melanie_Gilligan
- 106 <https://www.plattformplattform.ch/Ausstellungen/PLATTFORM17>
- 107 <https://www.google.com/search?client=firefox-b-d&q=Bonnie+Camplin+>
- 108 <https://www.francescapia.com/artists/sam-pulitzer/biography>
- 109 <https://www.mutualart.com/Artist/Bea-Schlingelhoff/D02FB6036F1234E1/Biography>
- 110 <https://flash---art.com/article/bri-williams/>
- 111 https://en.wikipedia.org/wiki/Silvia_Kolbowski
- 112 <https://www.hkst.de/de/maecenas/stipendiatin-laura-langer/>
- 113 <https://www.sandy-brown.com/artists/NOCryND/daphne-ahlers/>
- 114 https://de.wikipedia.org/wiki/Nicole_Wermers
- 115 <https://www.mutualart.com/Artist/Romane-Chabrol/46DC6181060B2DD3>
- 116 <https://www.glarus24.ch/artikel/helene-fauquet-flora-klein-und-marc-egger-im-kunsthaut-glarus-2438713>
- 117 <https://www.maxmayer.net/artists/flora-klein>
- 118 <https://kow-berlin.com/artists/sophie-gogl/biography>
- 119 https://en.wikipedia.org/wiki/Karen_Kilimnik

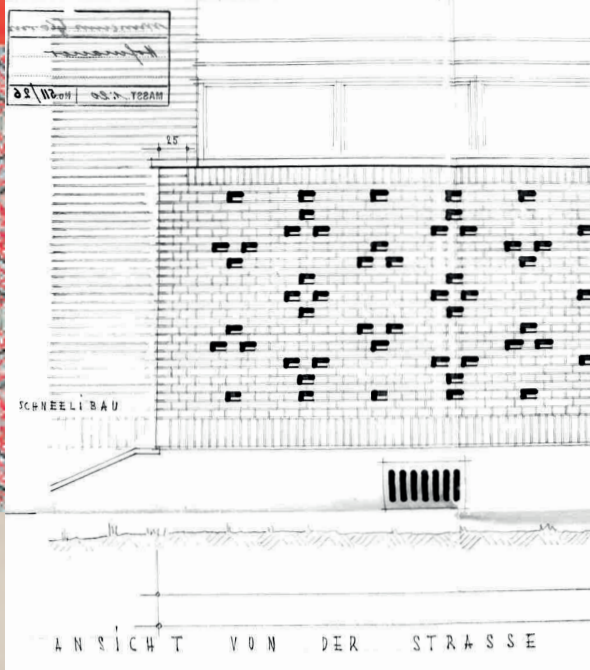
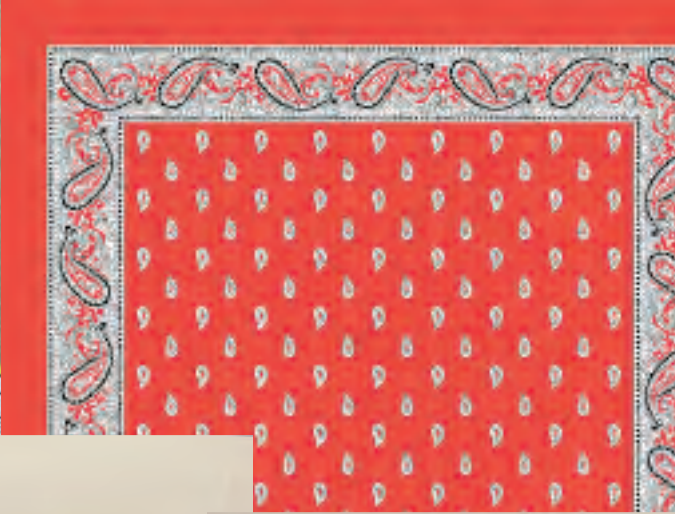

USFÜHRUNG: TAFEL
ARMIER



KUNSTHAUS
UND
BIOLOGISCHE SAMMLUNG

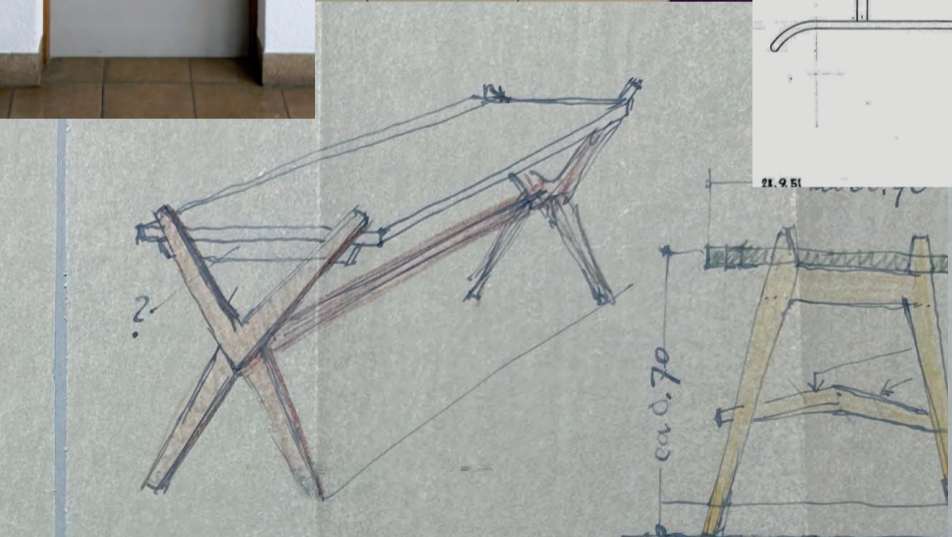
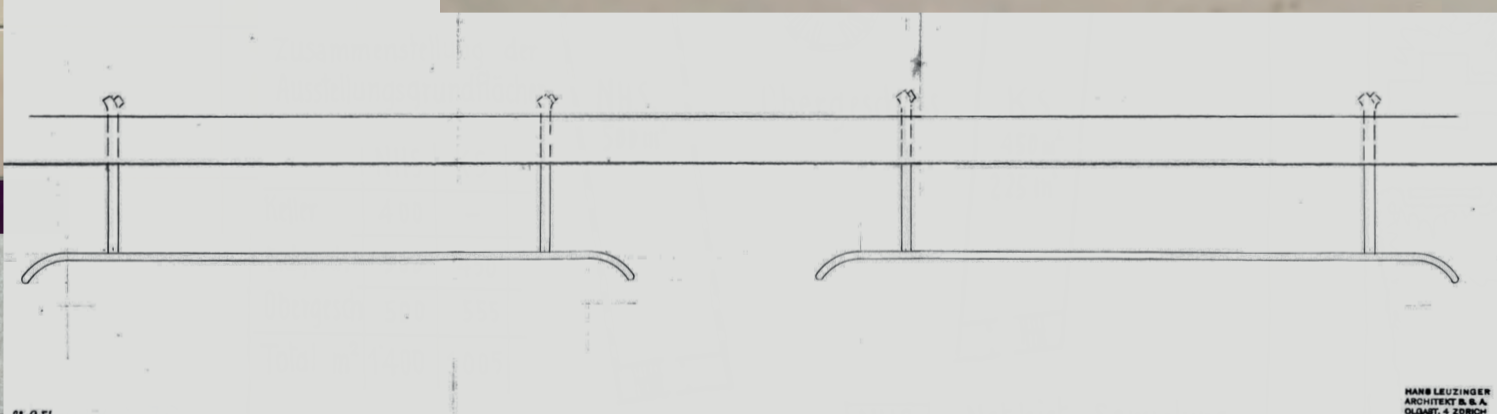
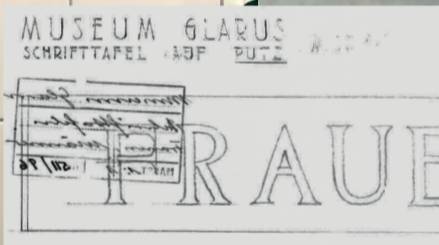
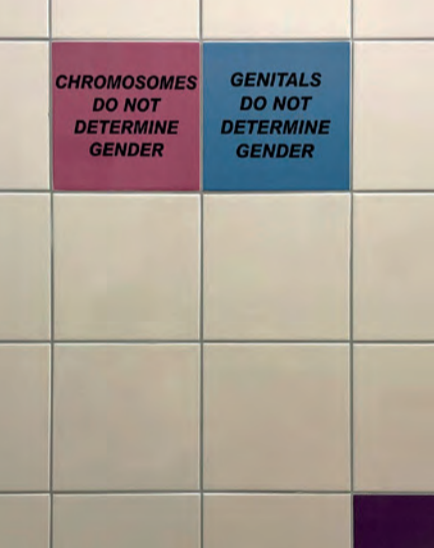
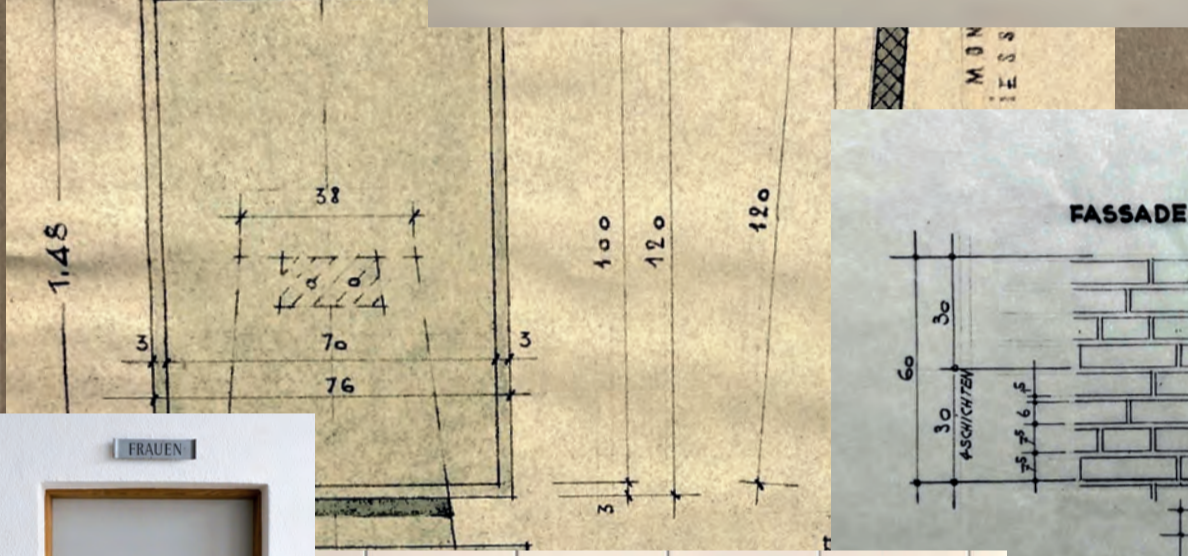

Bildersaal 10,0x20,0 m
Ermittlung der Wandfläche.

NHS Natürl. Sammlung
KS Kunst Sammlung

Wstfäll. Pr. R. Mag.

Masstab
2x20
4x4
8x2x2
total

669

VII. Zeugdruckerei-Firmen in der Schweiz.
Verzeichnis für das Jahr 1901.

a) Im Kanton Glarus:

1. Trümpy, Schäppi & Cie., Baumwoll-, Woll- und Seidendruckerei in Mitlödi.
2. Barth, Jenny & Cie. (seit 1. Juni 1902 umgeändert in Daniel Jenny & Cie.), Mouchoirs-Druckerei in Ennenda.
3. P. Blumer & Cie., Mouchoirs- und Yasmas-Druckerei in Schwanden.
4. Gebrüder Blumer, Battick-Druckerei in Schwanden.
5. Gebrüder Freuler & Cie., Mouchoirs-Druckerei in Ennenda.
6. Egidius Trümpy & Cie., Battick- und Yasmas-Druckerei in Glarus und in der Mettlen bei Netstal.
7. R. Leuzinger (seit Oktober 1902 umgewandelt in die A.-G. Baumwoll-Druckerei Hohlenstein), Battick- und Mouchoirs-Druckerei in Glarus.
8. Gebrüder J. u. J. H. Streiff & Cie., Yasmas-Druckerei in Glarus.
9. Gallatin & Cie., Yasmas-Druckerei in Leuggelbach.
10. Tschudi & Cie., Türkischrot- und Bunt-Färberei und Türkischrot-Druckerei in Schwanden.
11. C. u. J. Luchsinger & Cie., Druckerei von Batticks etc., in Näfels.
12. Friedrich Oertli, Türkischrot-Druckerei in Näfels.
13. Felix Kubli's Söhne, Mouchoirs-Druckerei in Netstal.
14. J. de H. Brunner, Yasmas-Druckerei in Glarus.



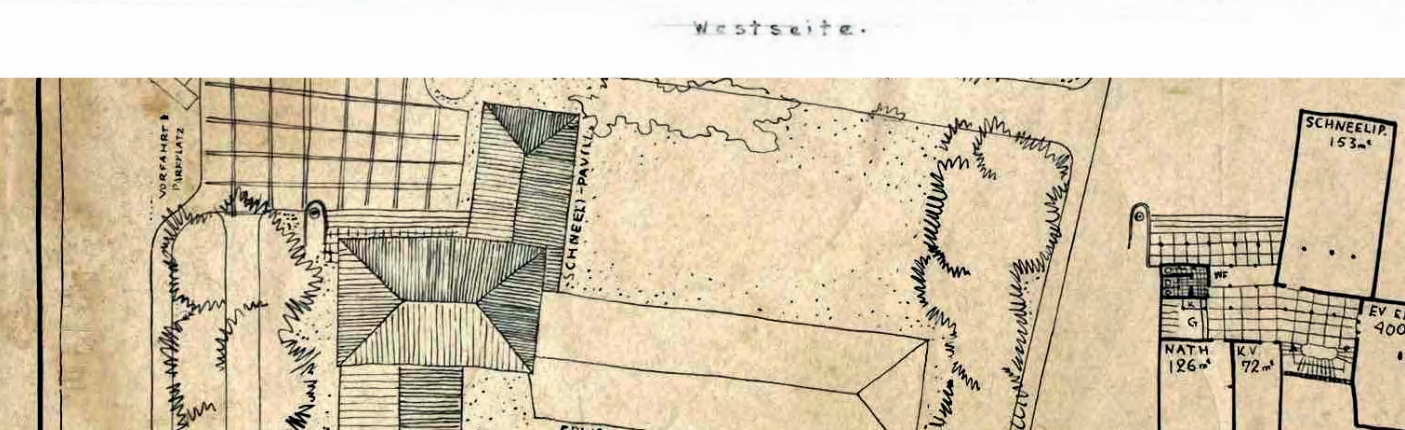
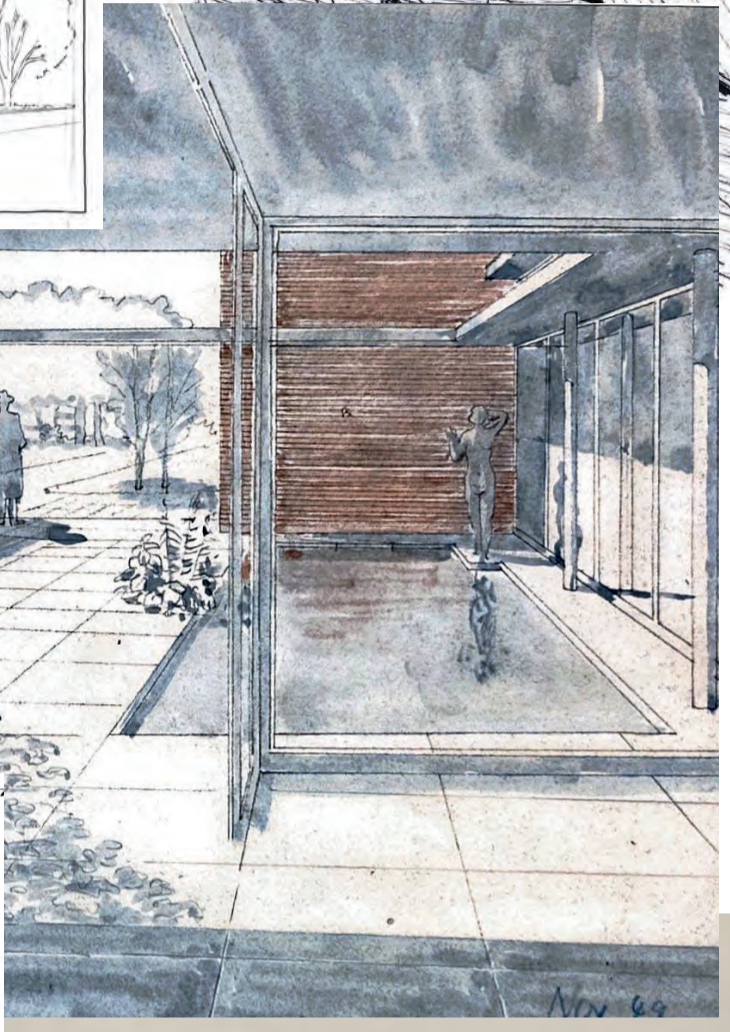
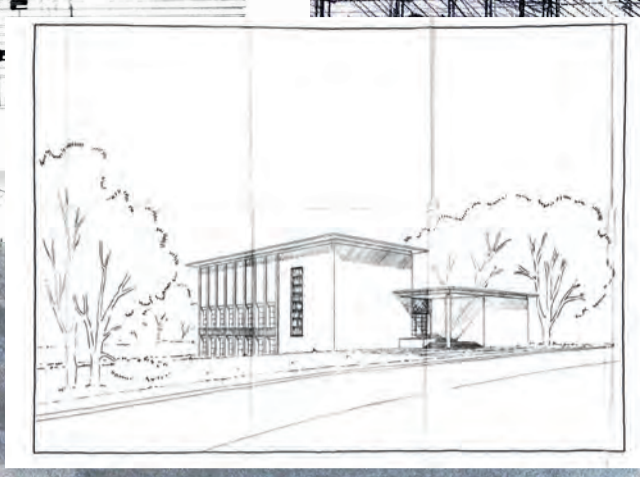
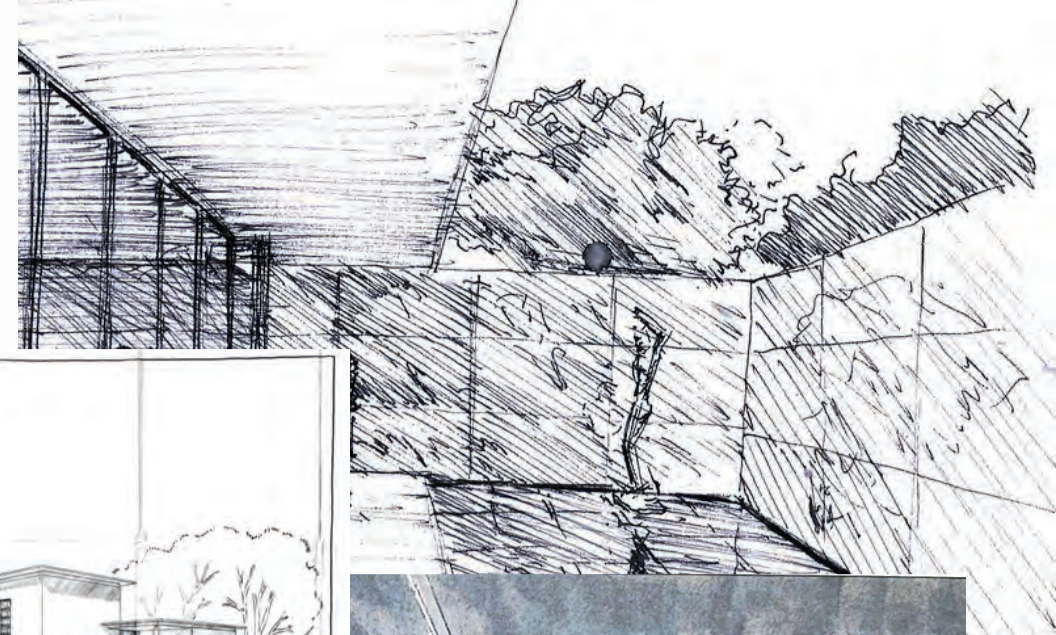
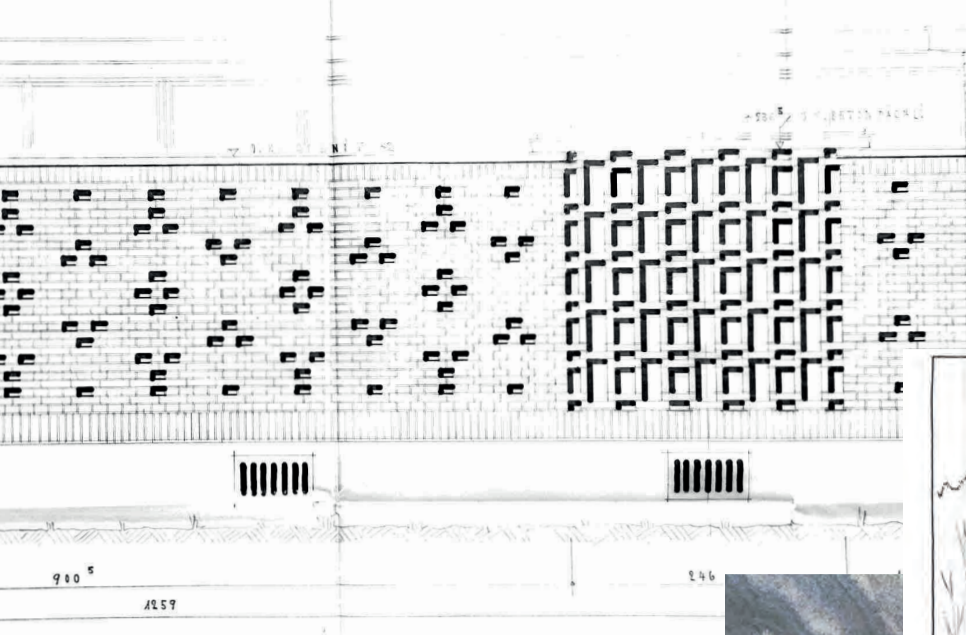

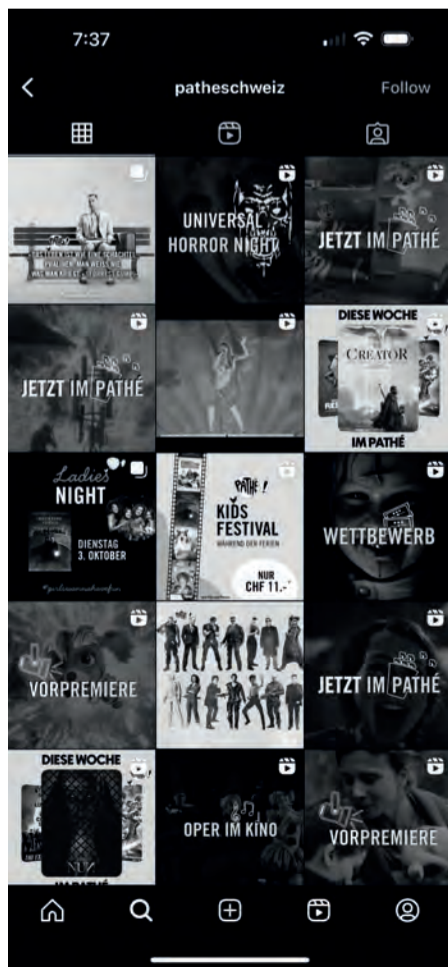
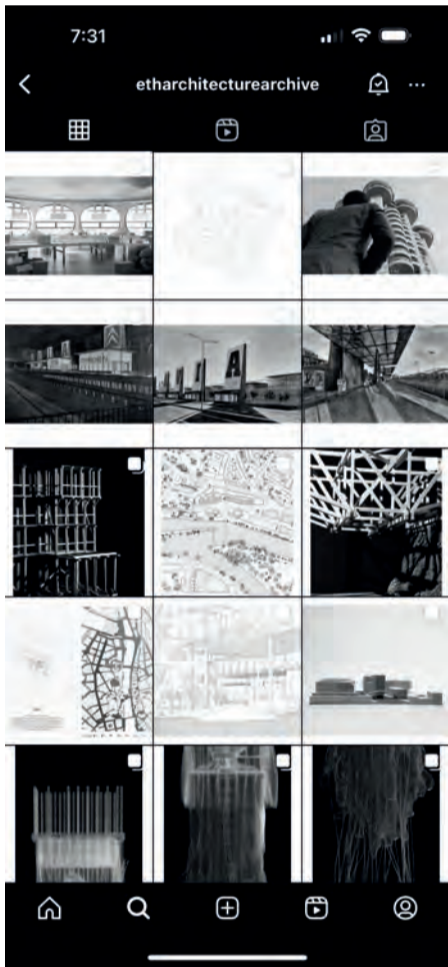







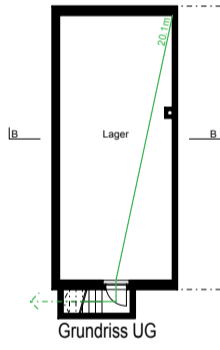
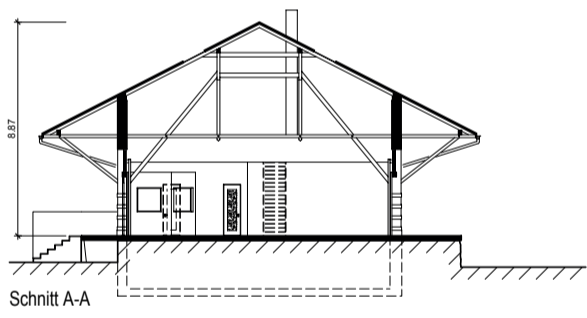
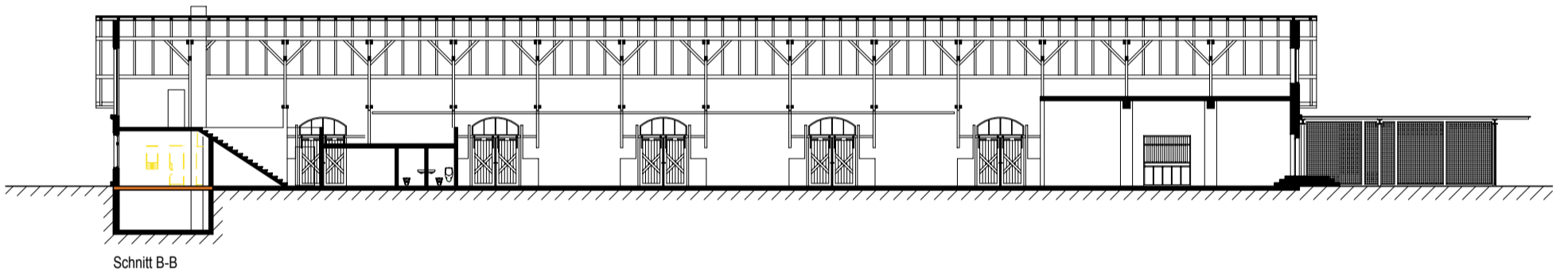

A]

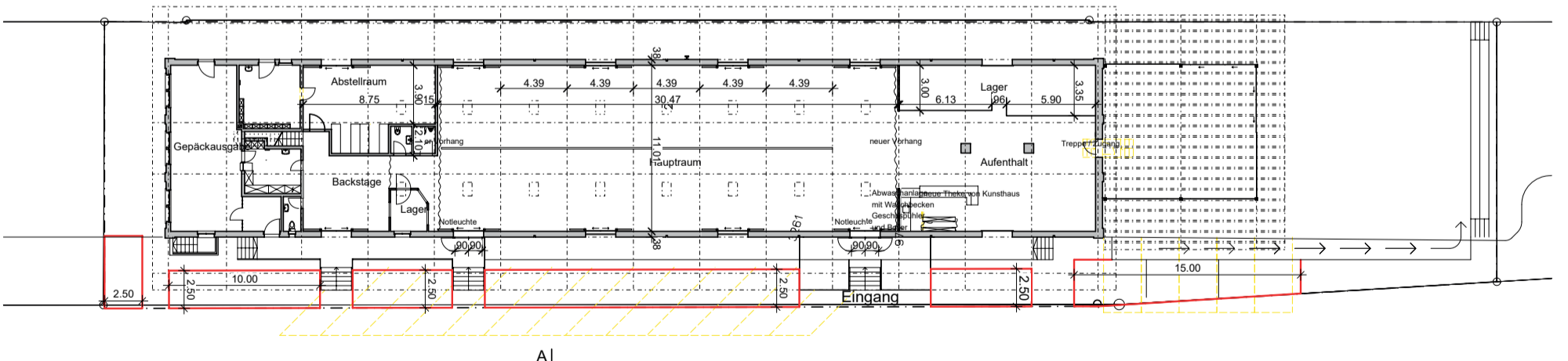

Question for Discussion with Melanie and Judith

Exclusion

Today's society is diverse and presents itself in different shades. This topic has also found its way into museums with the slogan of inclusive museums. How does this influence the trade of contemporary art museums on the one hand in relation to exhibitions by artists and on the other hand in relation to the cultural participation of society and what demands (wishes) arise from this for the architectural space?

How can architects support this through the built material?

How do rural museums, which tend to have a conservative audience, deal with this in comparison to cities, which are more open to the world?

Allegory

Since the architectural epoch of modernism, museums themselves have become art objects and symbols of the city marketing of our time, which makes change difficult and one has to ask oneself how sustainable this is, because sustainability has not only to do with resources but also with the use of the building, because only in this way is a building sustainable in the long term and legitimise its use for society. How do museums react to this development?

Example Puppies Puppies issues of the current society debate are locked in an architecture that becomes an art object.

Access

The Kunsthauus Glarus with its modern typology has focused on contemporary local and international art. Are modern building structures still useful for contemporary art, to use a term the white box?

Museums, among other things, compete with each other in terms of visitor numbers to underline their legitimacy, is an art house in the periphery still relevant compared to big cities where culture accumulates?