

universum carrousel journey  
re-practice prac-teach – a method  
making meandering meaning – the studio  
final review – spring 2020

**Janis Stainhauser**

**Patricia Gama**

**Ralf Schweizer**

universum carrousel journey – a studio  
carrousel journey universum – a practice  
journey universum carrousel – whatever  
Studio Jan De Vylder  
ETH Zürich D-ARCH IEA – FS 2020



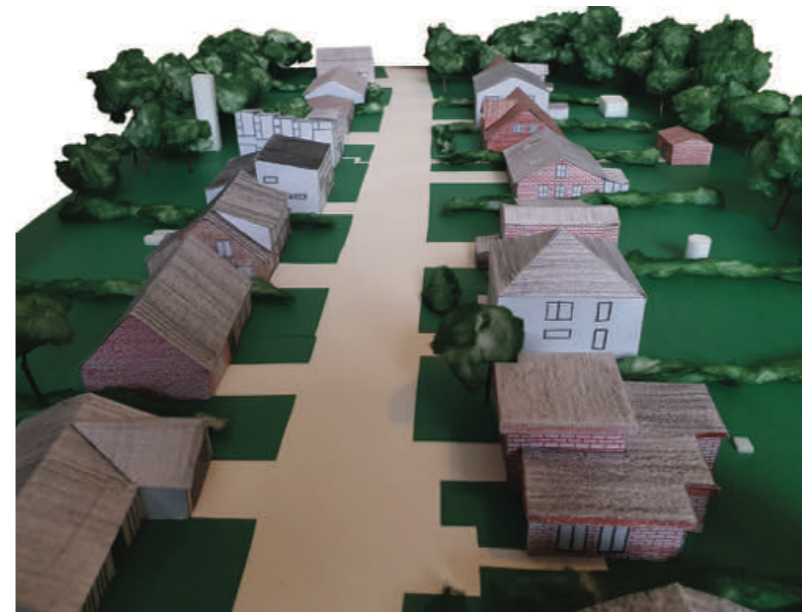

# Movement 1

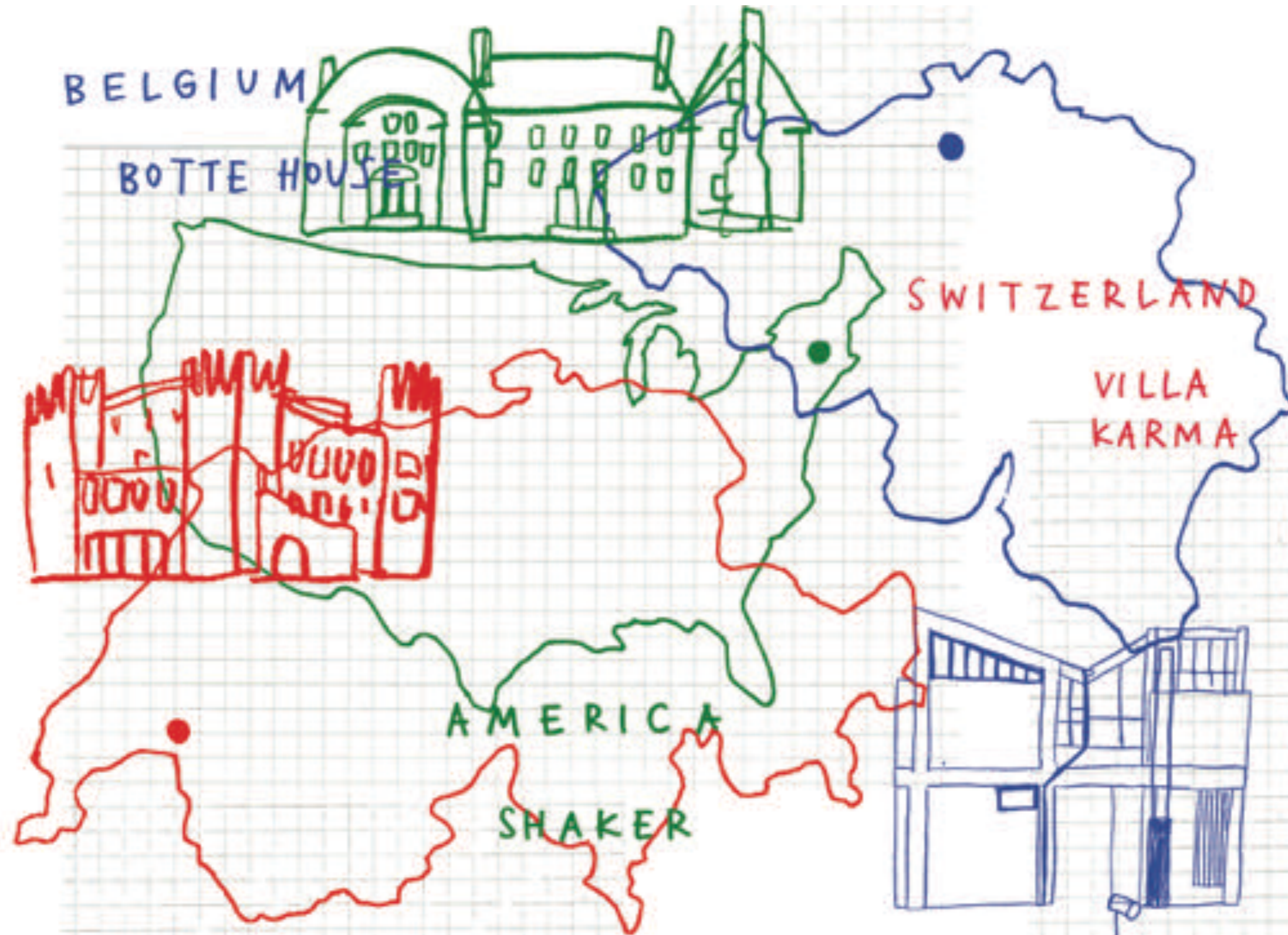

# Movement 1

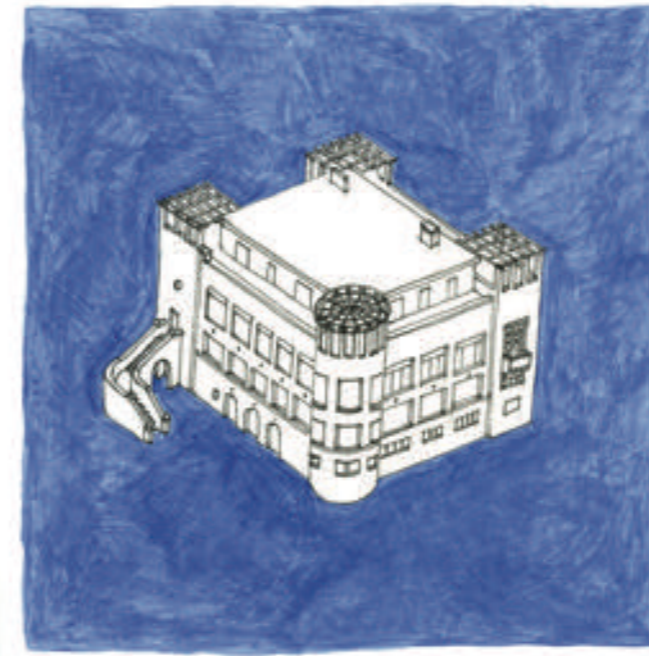
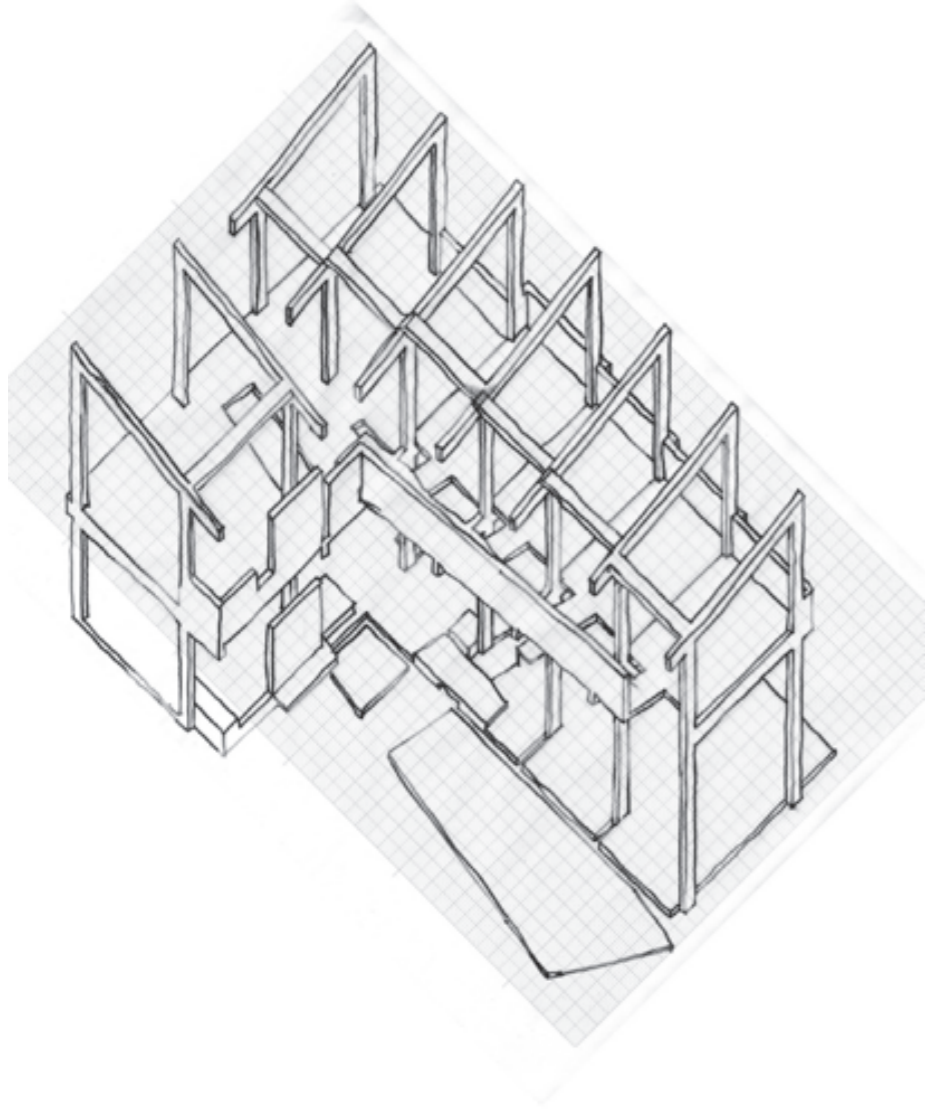

CLADDING  
CASTING  
CRAFTING



# Movement 1

~~CLADDING~~  
CASTING  
~~CRAFTING~~

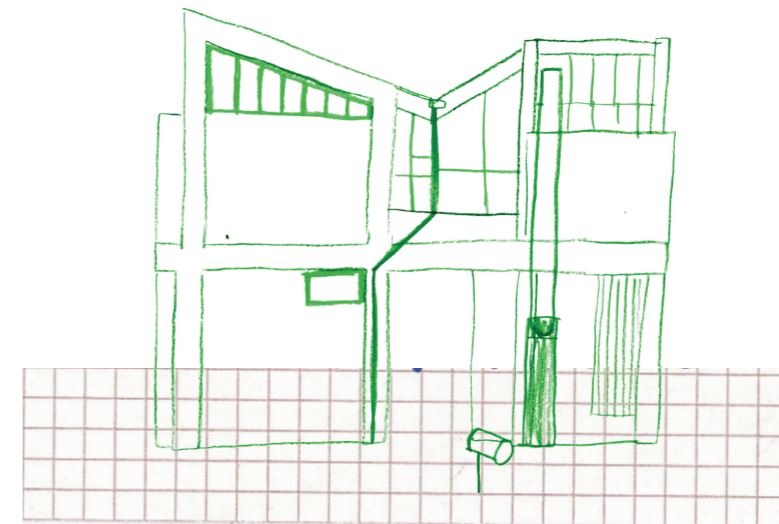

Botte House Bob van Reeth 1970

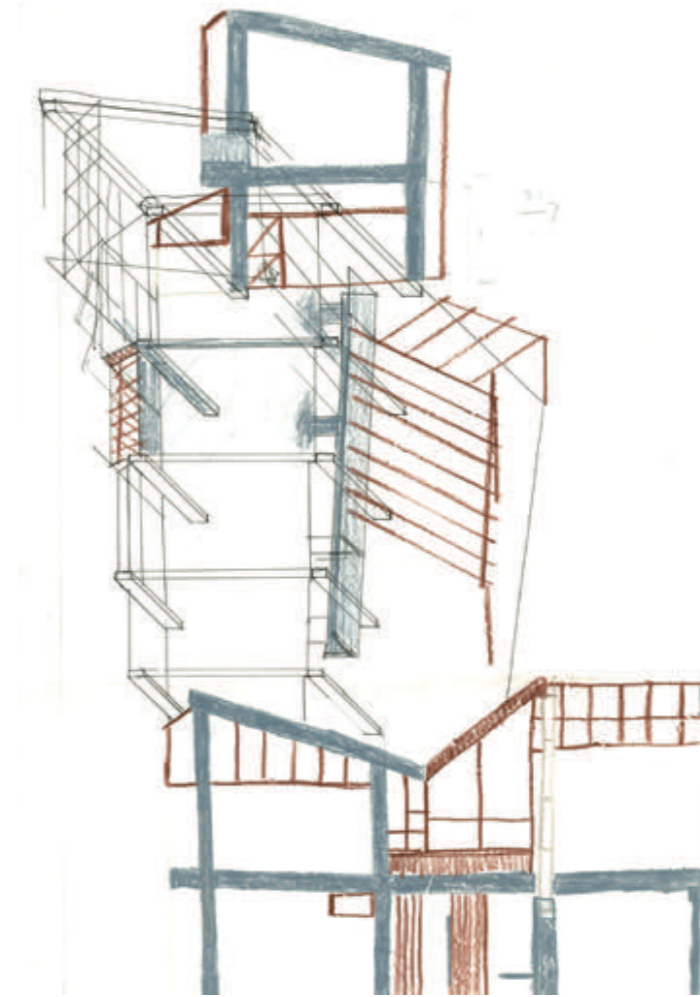

## Botte House (BE) - Bob van Reeth, 1970

I sit in the warm, light-flooded living room. The plants grow vigorously in here, I like that it creates a smooth transition to the garden. A slight twittering of the birds leaks through the thin windows. Nevertheless the room gives me a feeling of security and home.

Due to the thick supports and the high ceiling of raw concrete the room feels very solid and at the same time very light. Like trees sitting on rocks, the wooden elements settles on the concrete.

Upstairs I can hear the dump sound of rounds rolling down on the massive concrete. The children are playing with their marbles. They are fascinated by the sloping ramp. Again and again, a hollow sound is heard, the balls roll against the wooden door at the end of the corridor. One keeps running up and down to collect the balls.

Nothing new in the newspapers. The cars passing by on the freeway in the distance create a pleasant background noise. Sometimes I can't even tell if it's the cars or the wind.

If it wasn't that windy I would sit in our courtyard. Strangely enough, my favorite place of the house is located outside.

I was awakened from my thoughts by a rattling bang. Must be the window in the kitchen again.

I trip over some toys on my way to the kitchen, close the window and put on the kettle. Some people might find the creaking noises of the lighter structure annoying and may say that it was constructed cheaply. But they give me some kind of a comforting feeling, like I'm having a conversation with the house.

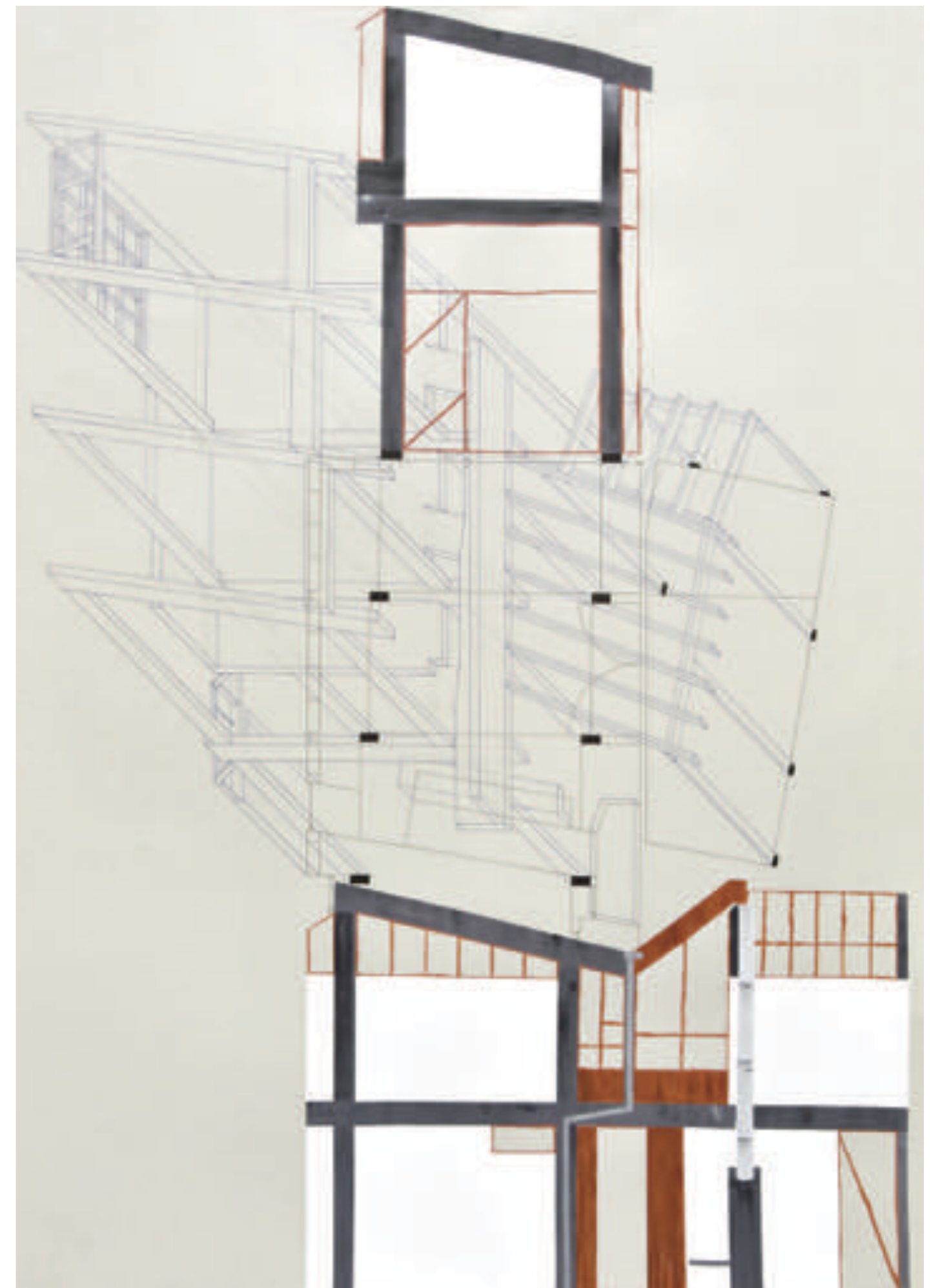





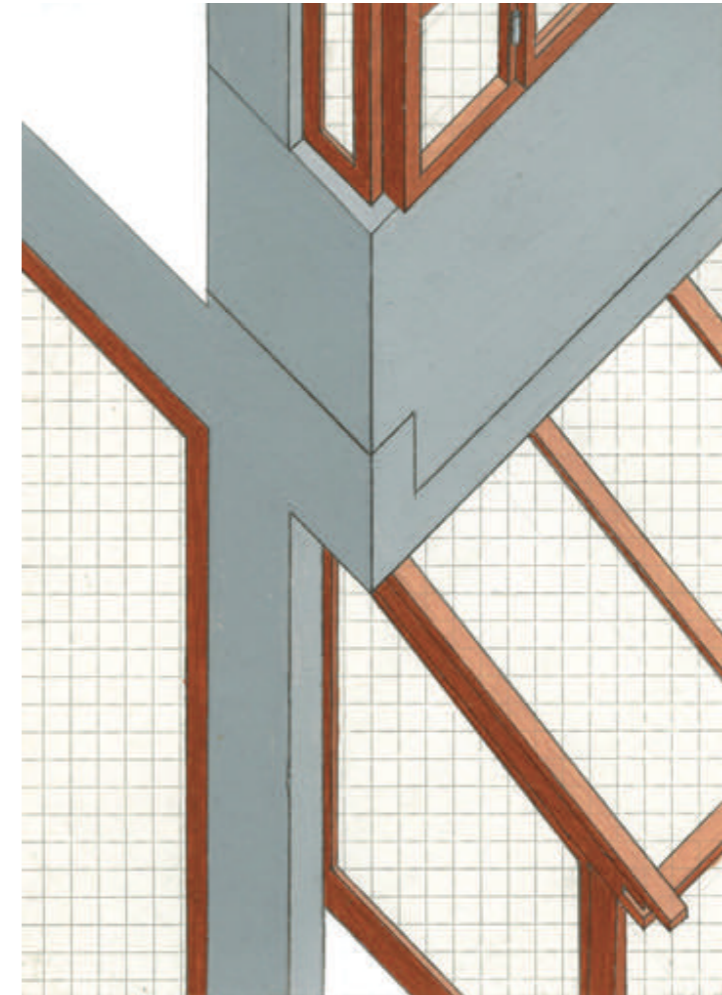
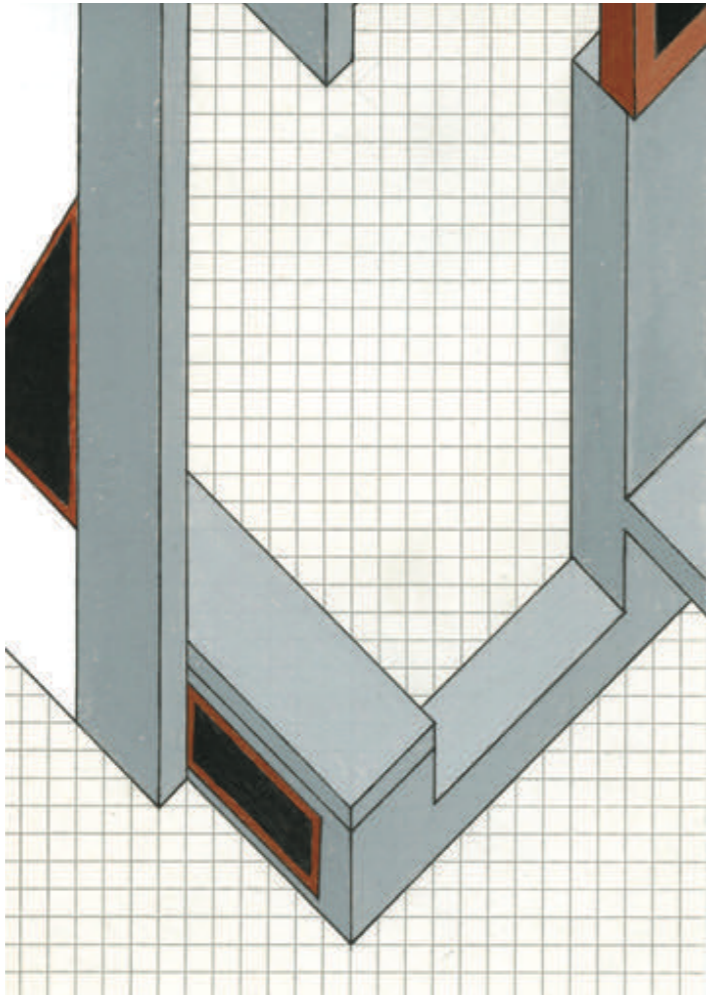

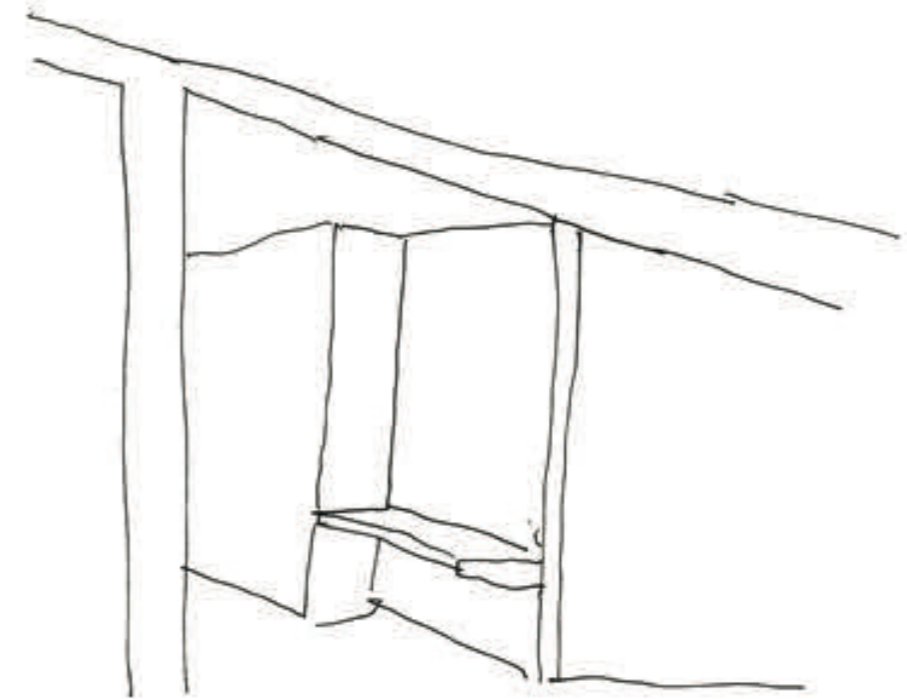
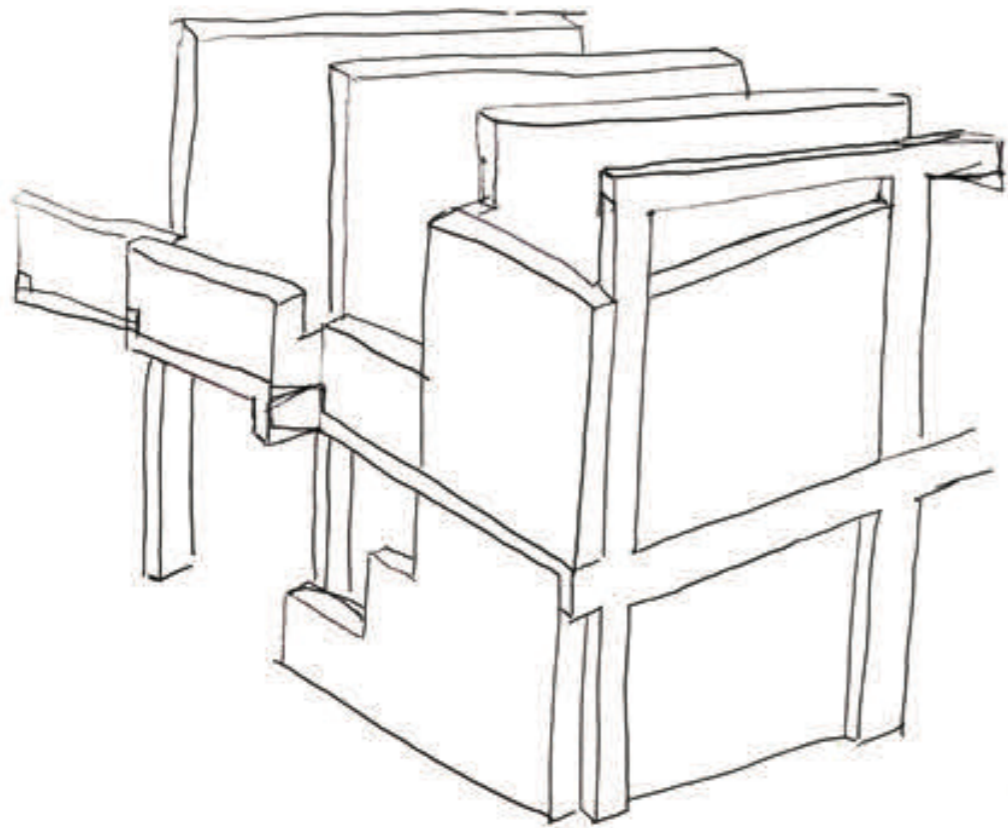
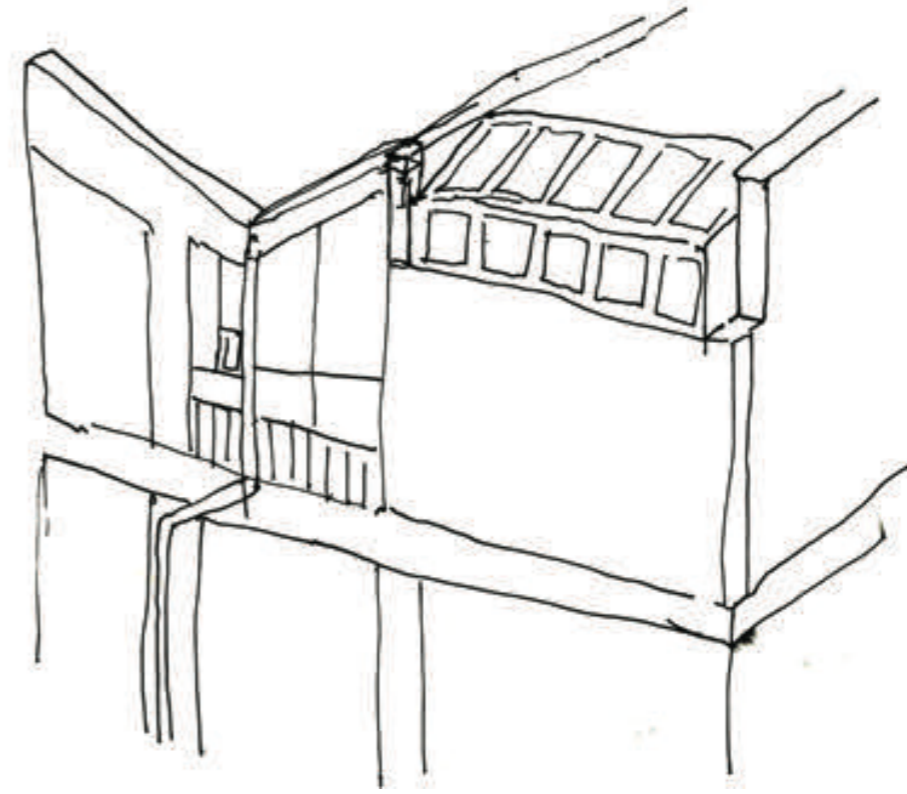
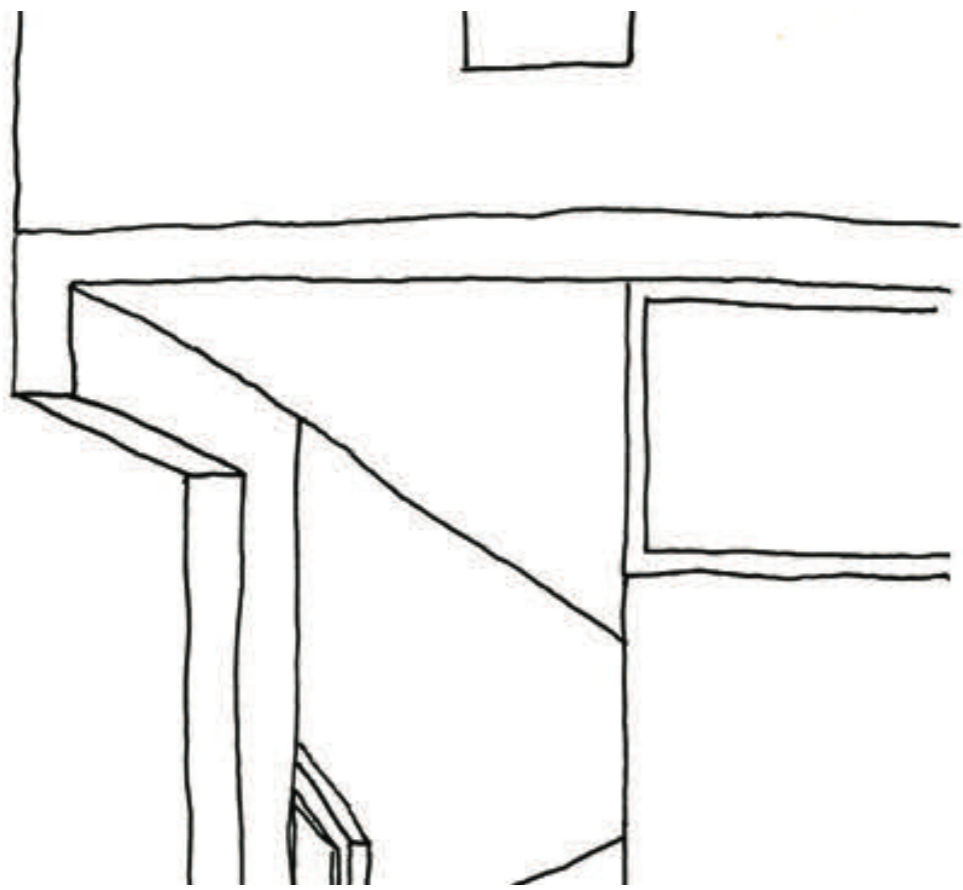



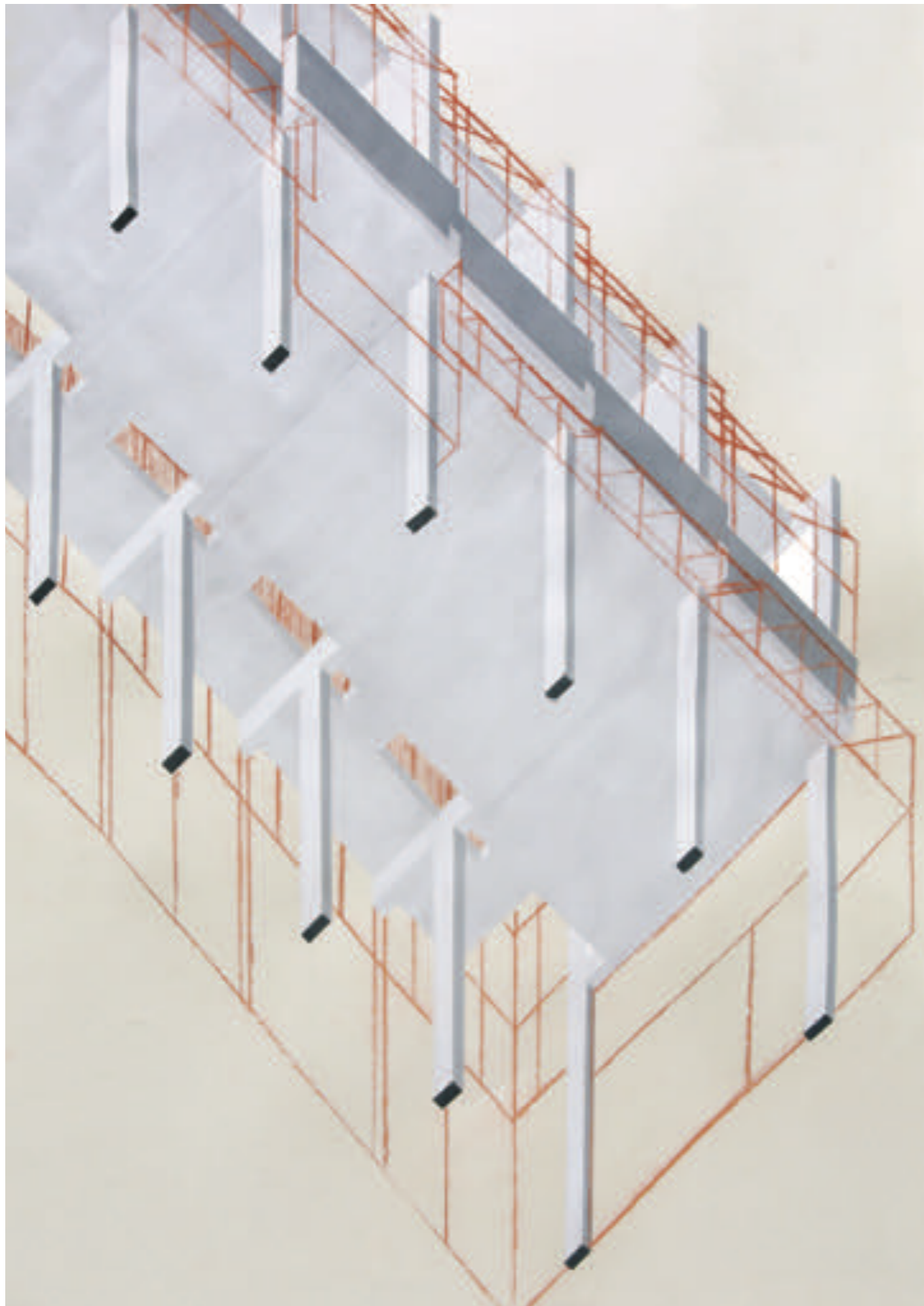

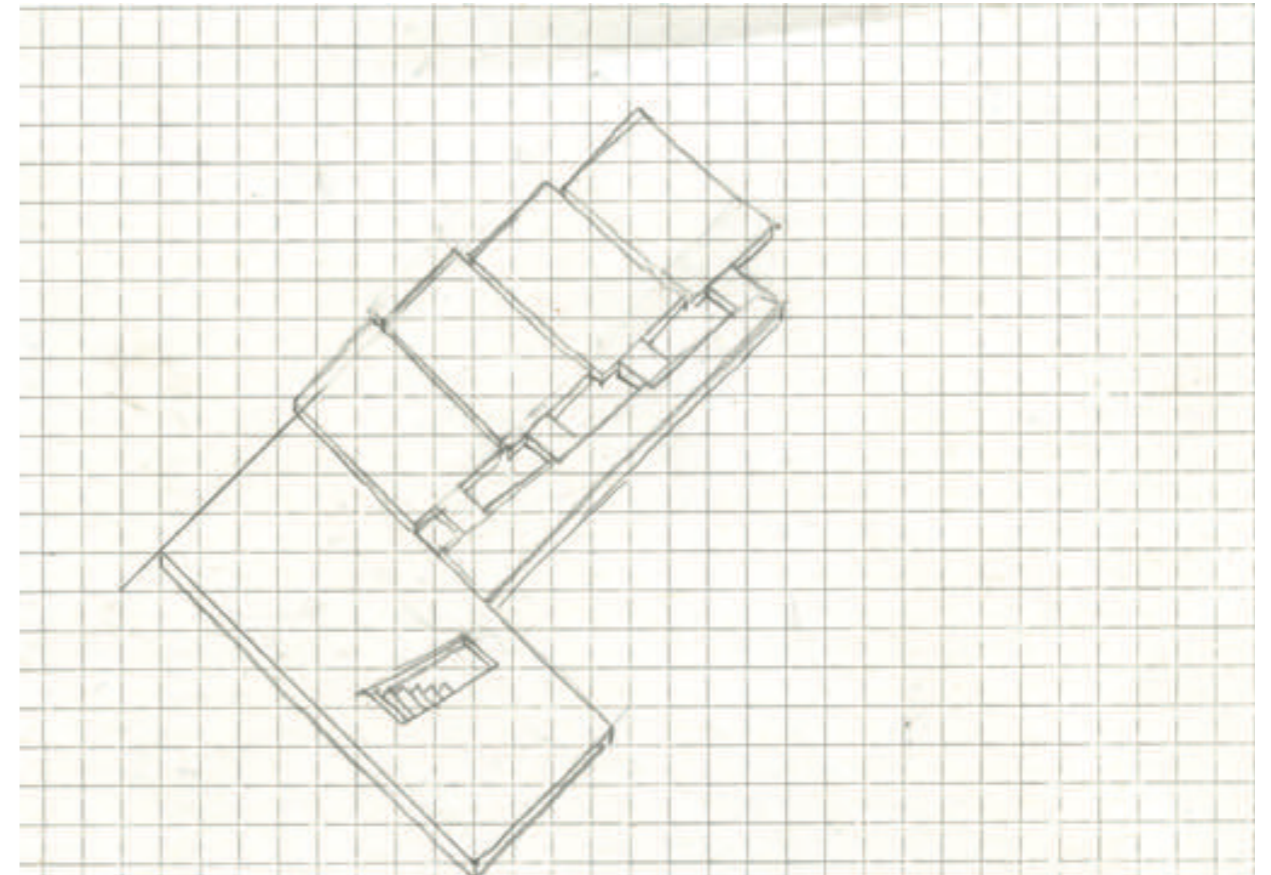
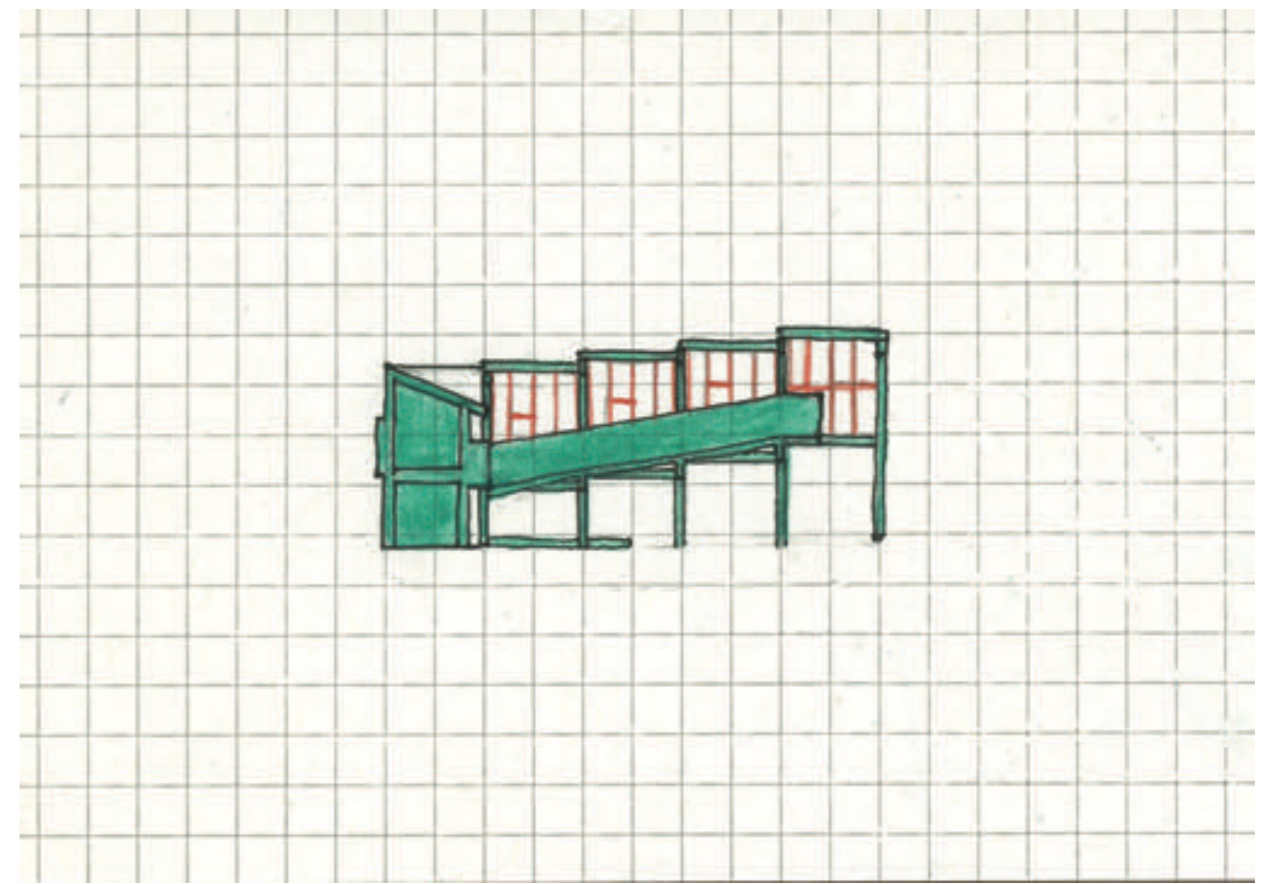

# Movement 1

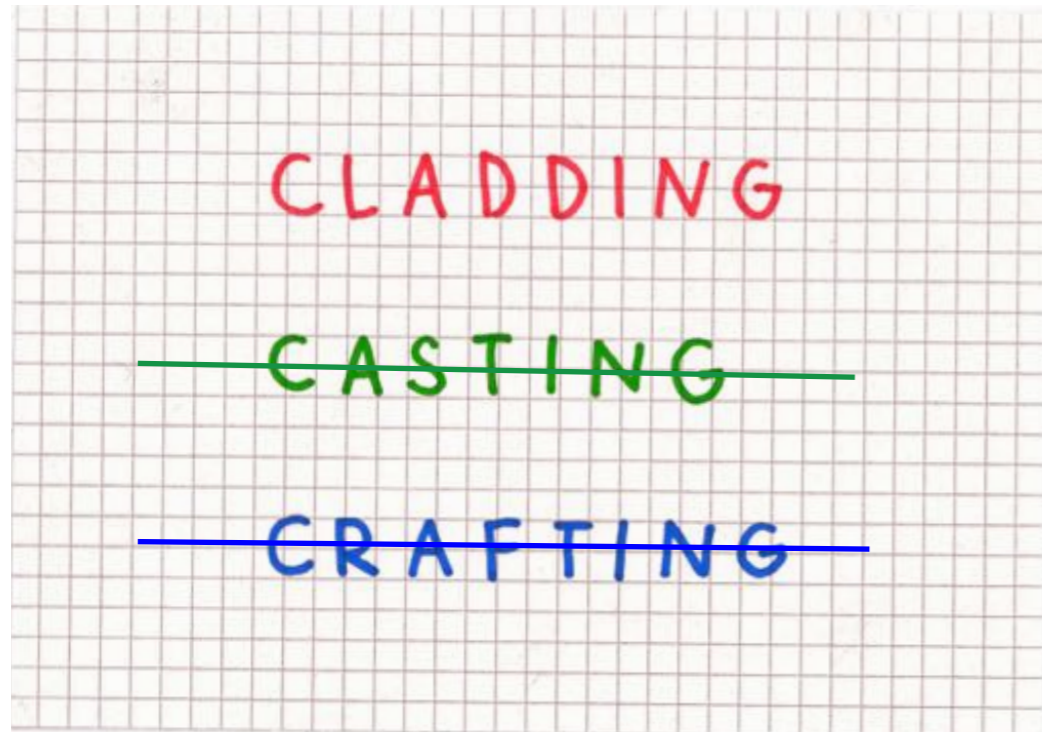

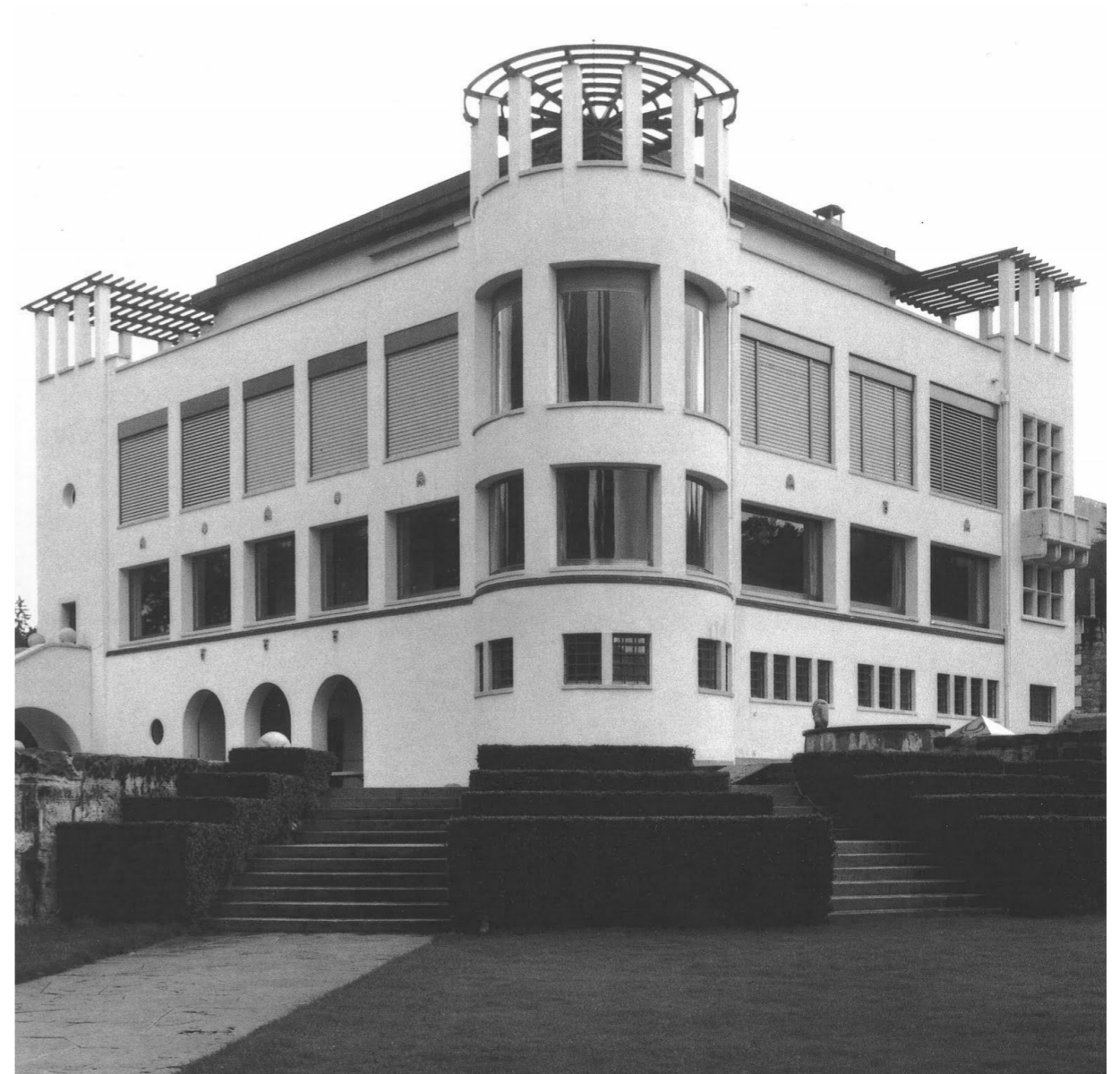



## Villa Karma (CH) - Adolf Loos, 1903-1906

He takes the first steps towards the mighty gate, steps made out of stone. Before walking through the column row, he pauses briefly, takes a look back, and lights up a cigarette.

Entering the door, he finds himself in a elliptical space; a clash of patterns, materials and shiny surfaces. He doesn't know where to put his eyes, takes a drag from his cigarette and watches the smoke rising through the levels.

Attracted by the dark behind the door, he steps into the unknown - as he wanted to get lost - through a carefully crafted wooden door and disappears from the image.

He got to the core trying to find a path through the labyrinth of thick walls, stairs up, stairs down, sometimes a window to another room, sometimes a dead end.

All covered in noble dark wood floors of marble, doors of gold, furniture coated with velvet in all colors. The complexity and contrasts of his surrounding mirror the thoughts in his head.

A ray of sunlight kisses his skin and he steps out of the dark core into the outer shell by which it is framed. Bright and soft, cozy and warm; he even gets a glimpse of the lake now.

He strolls along the endless bookshelf, not knowing if it was a corridor or a room to stay. furniture become walls and so do the floors. And all the materials feel like the building got a second skin.

He drops his cigarette onto the floor, and enters the stage again filled with confidence. In this castle, even the simplest gestures become a drama.





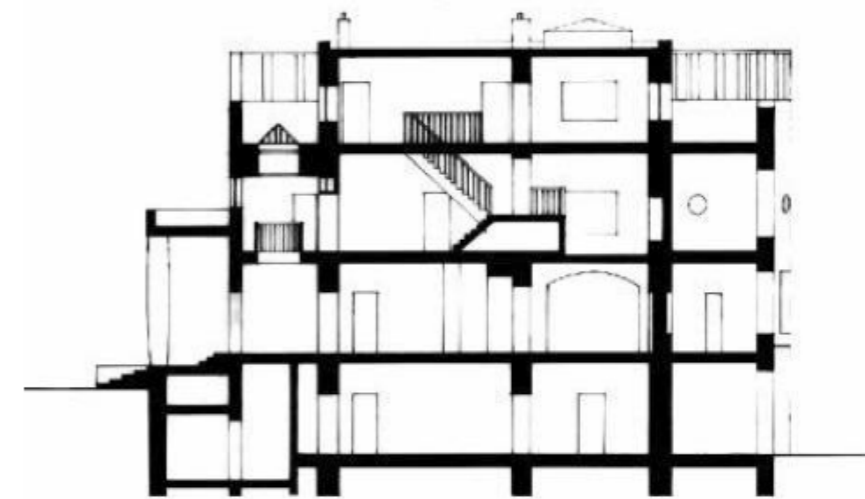
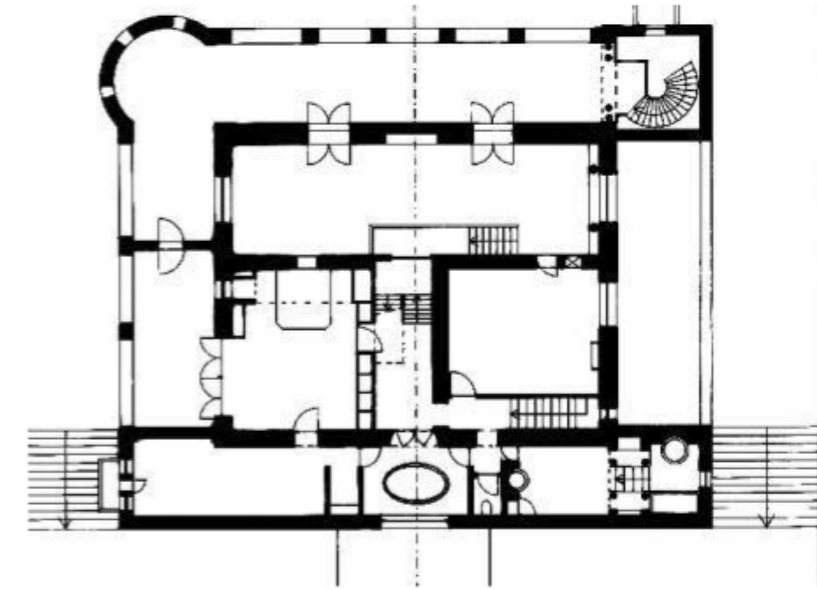
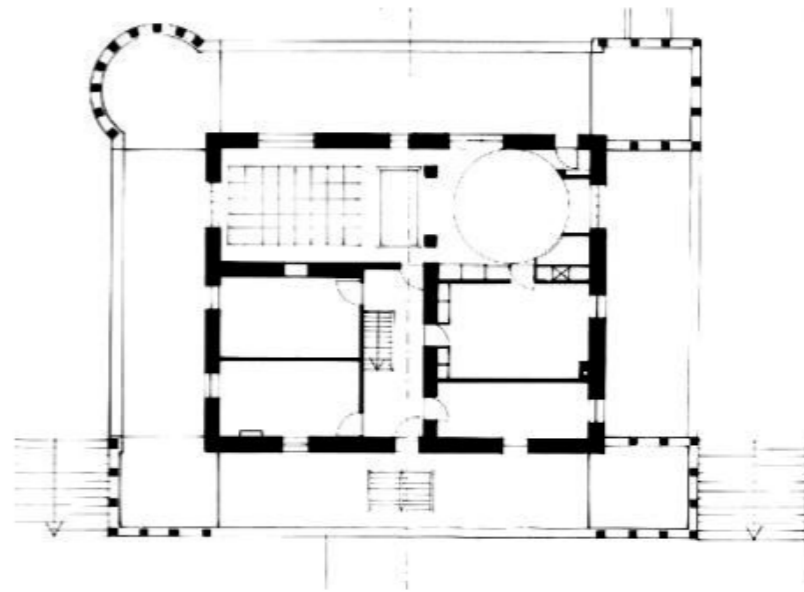
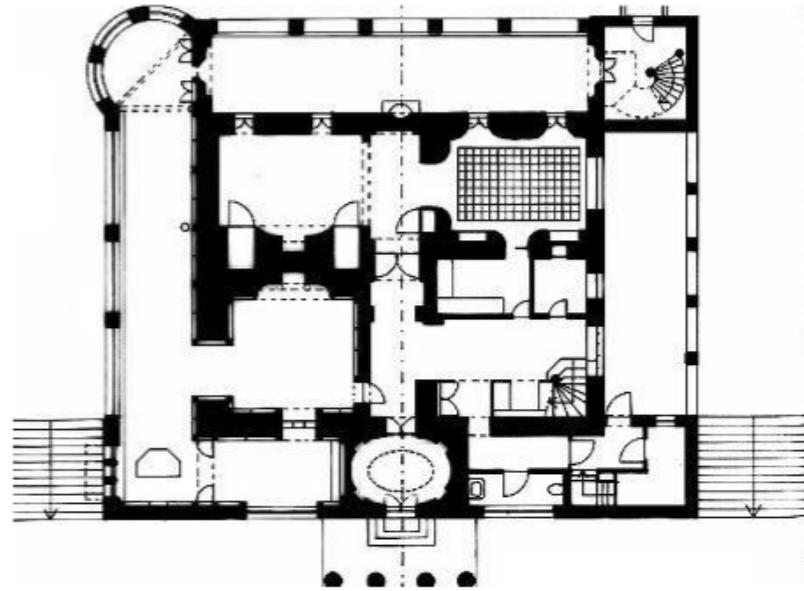

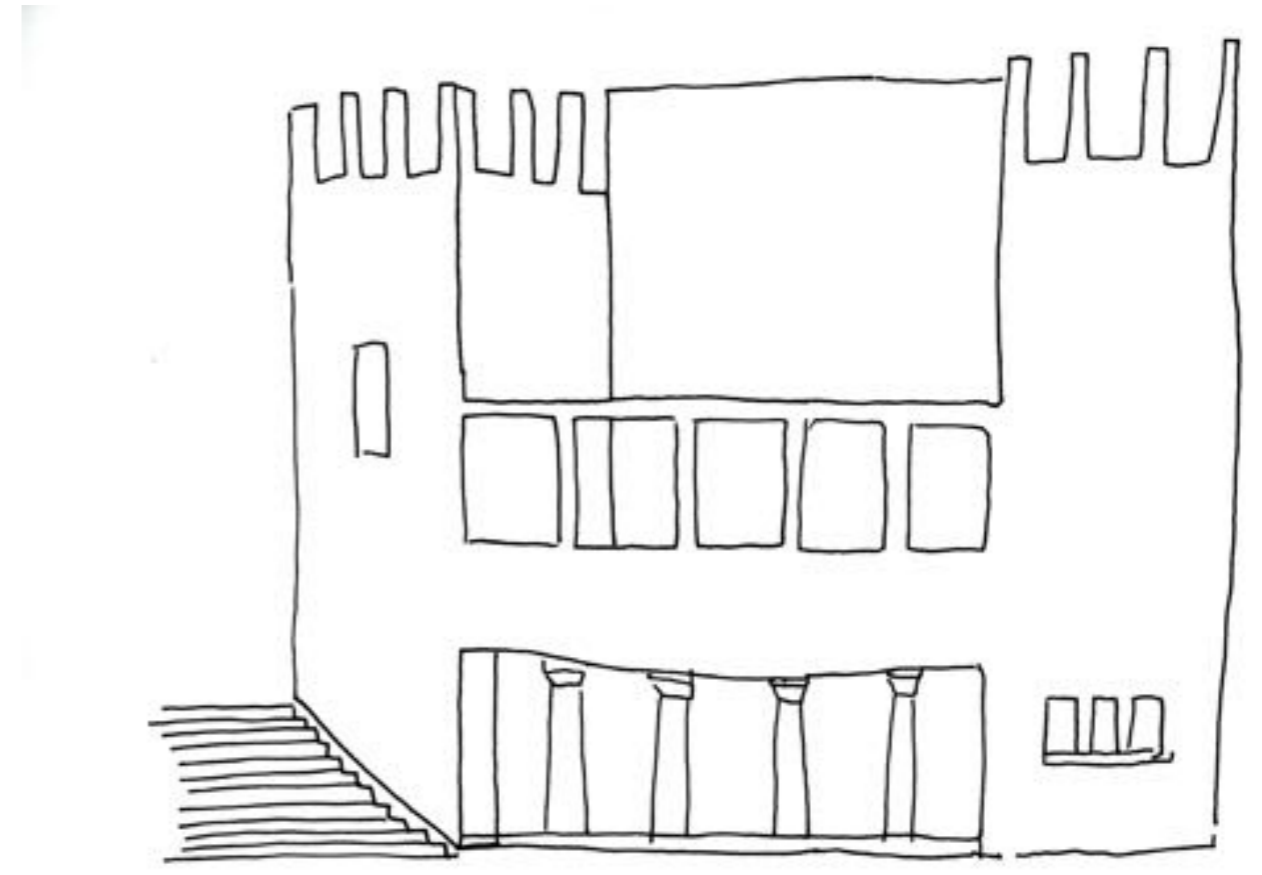

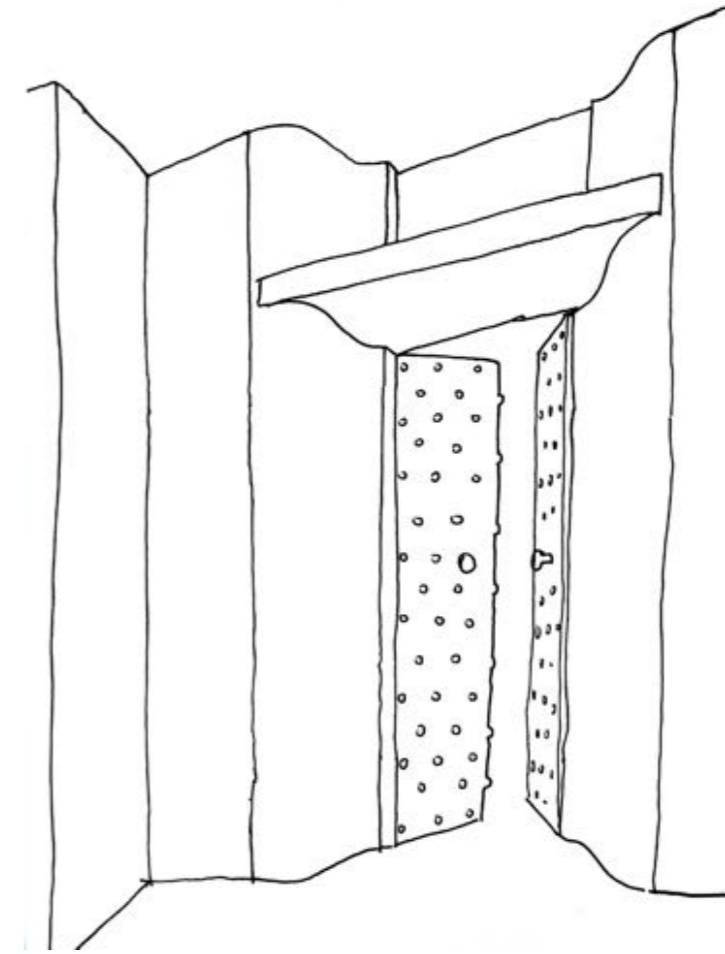
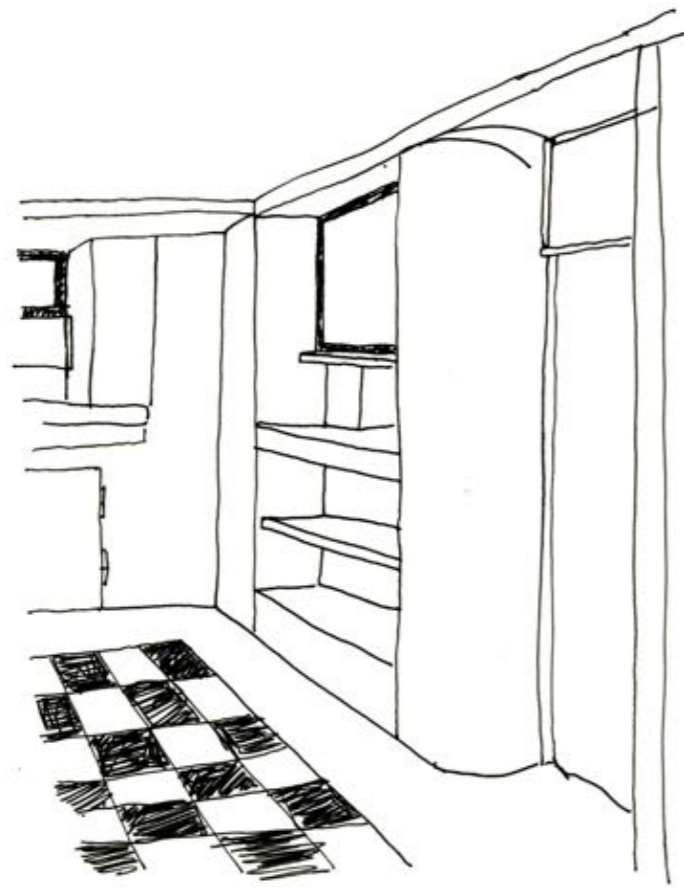

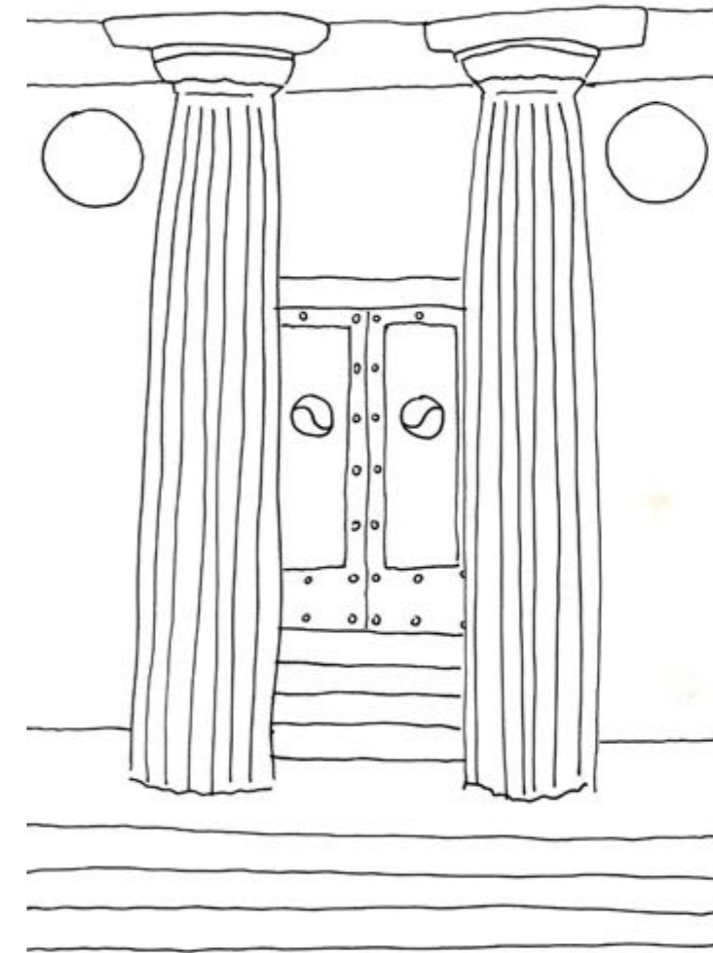
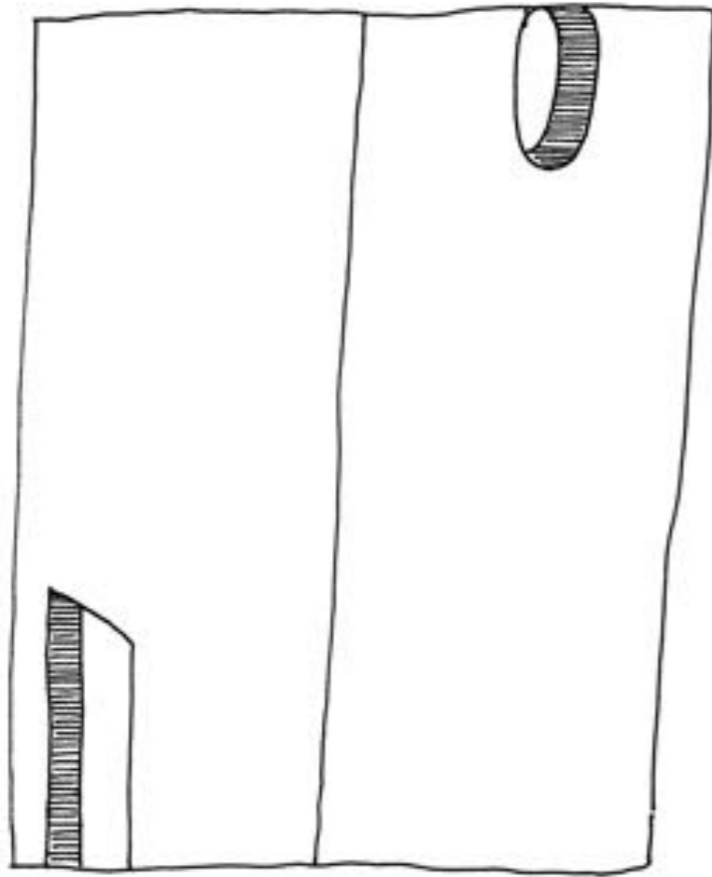

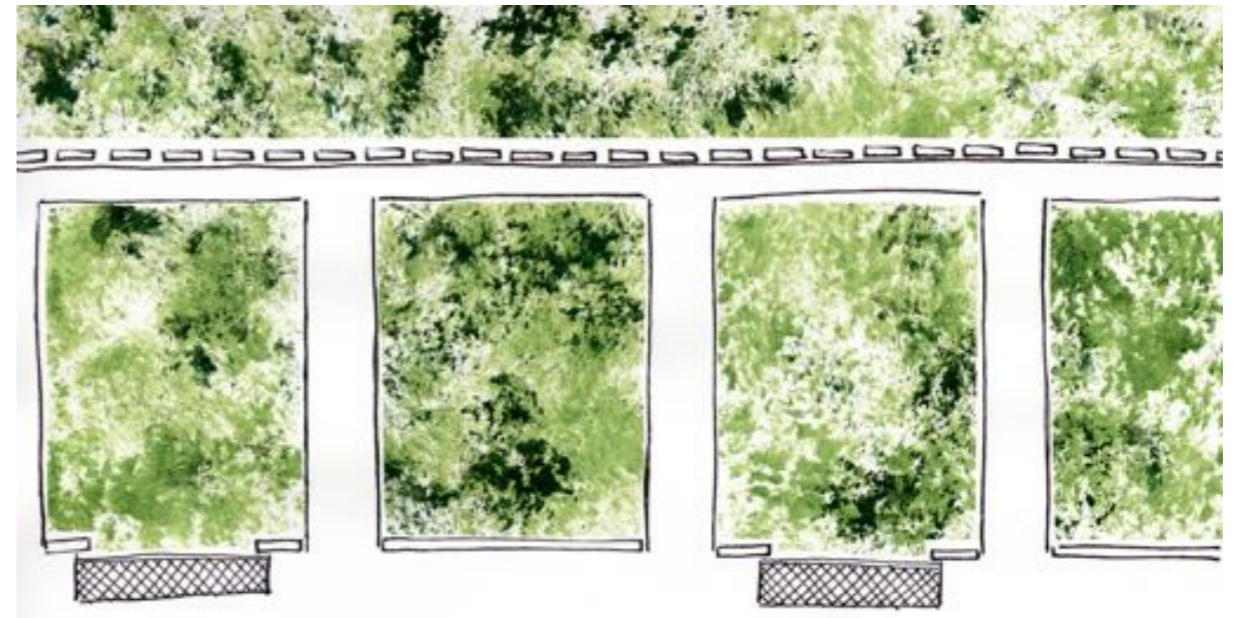
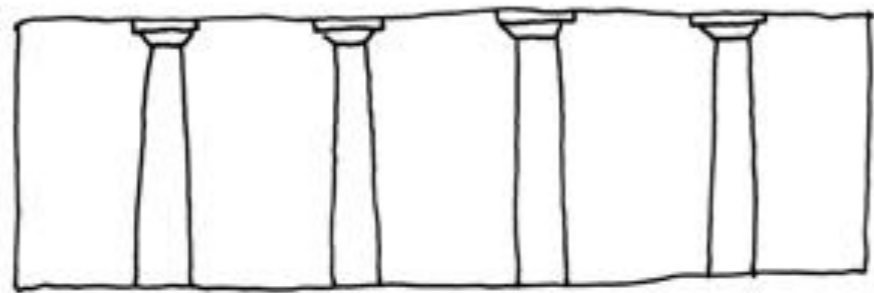

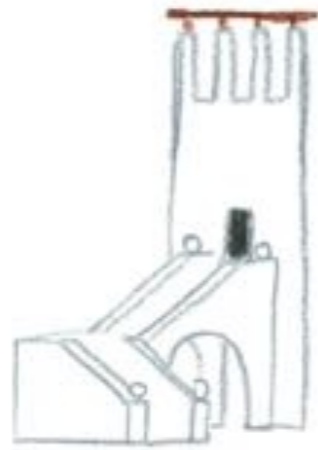











~~CLADDING~~

~~CASTING~~

CRAFTING

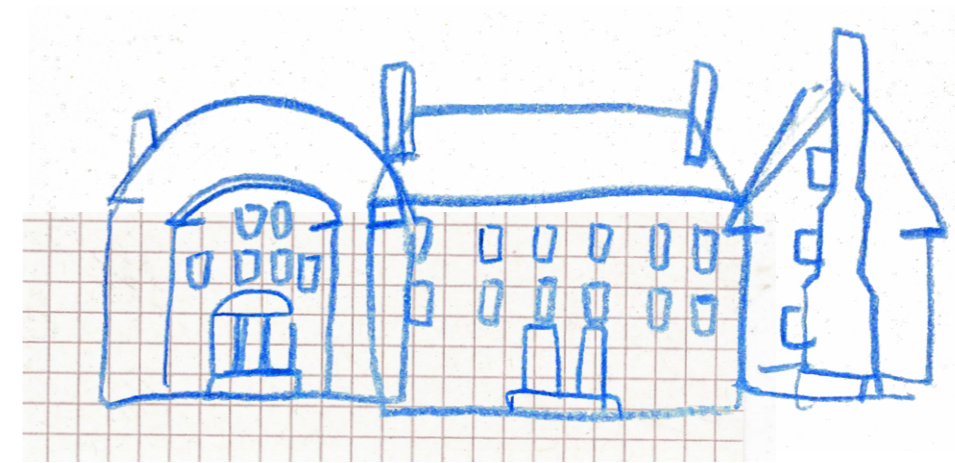

shaker houses 1850

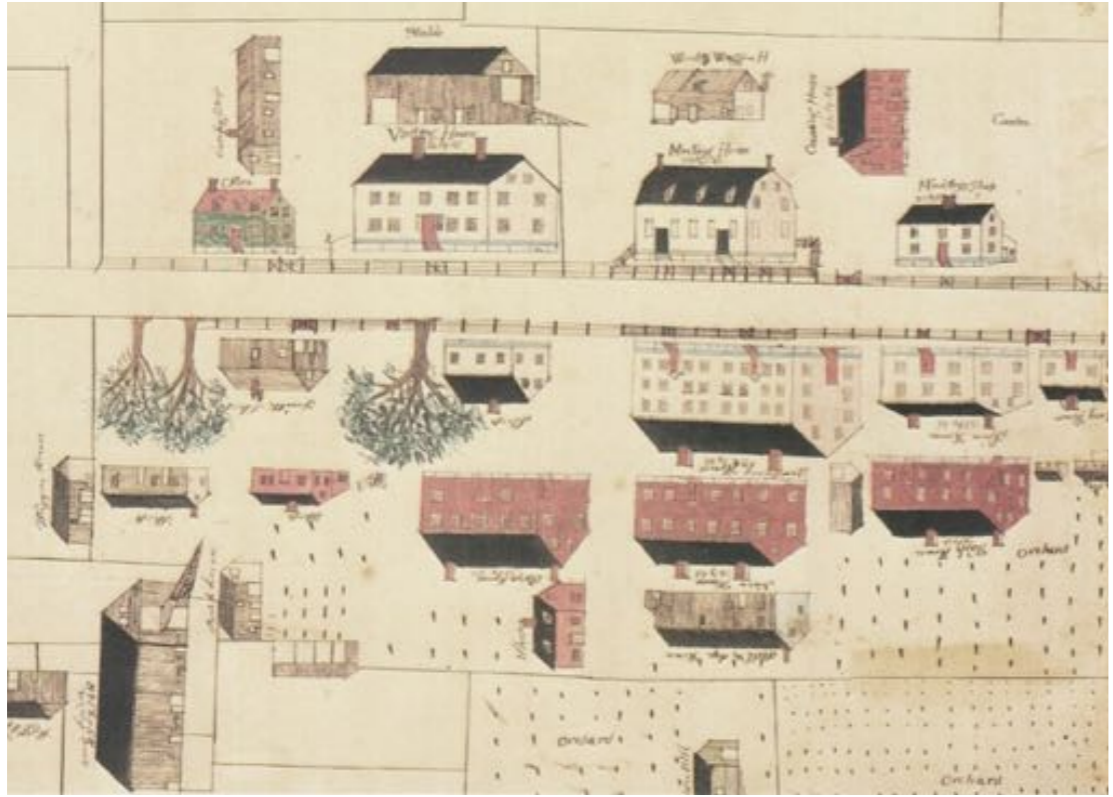

# Shaker Houses (US), 1850

I don't remember when I came here. It feels like I've been here forever.

In fact I'm here for so long that I forgot where I came from.

It feels like being locked up in this house. When my maker comes home he always gives me a lot of things to hold.

Sometimes I can barely see something and my body feels very heavy.

I get very tired, I lose every day more and more hooks and I don't even have the force to bypass the doors and windows, but nobody cares about.

Sometimes I lose control of the candlestick and the extremely hot wax is burning me.

I also got darker spots from the oven pipe, that is positioned too close.

After such days I like to hide behind the closet the whole night.

I'm the line that gives the room a below and an above but most of the people don't even recognize me.

I'm really focused on being beautiful for everyone.

Every day I try to help my family with the daily tasks as good as possible by giving them my free hands to carry little things like their jackets and hats or a broom.

They don't like to put their things in big wardrobes so our home is kept very simple.

They're appreciating my company and try to keep me always clean.

I love flowers and every Sunday my family buys me some.

On these days I'm super happy. Not even a rainy day could change that.

Being nice and helpful is what defines me.

Me and my little brother are living together. We are a very good team and we couldn't imagine a life without each other.

Our mission is to protect the sensitive walls of our home from holes and scratches from our clumsy owner. My brother is responsible for the lower and I'm for the upper part of the wall.

Since our owner got us he's much more relaxed because he knows he can trust us. It's important to keep the old walls safe, so they can live for many more years and we can keep our home.

We are very diligent and trying to do our best.

Sometimes we get very tired of the hard work but at the end of the day we always sleep well, knowing we have done a good mission.

It's important to get good sleep to gain enough strength to start again the next day.

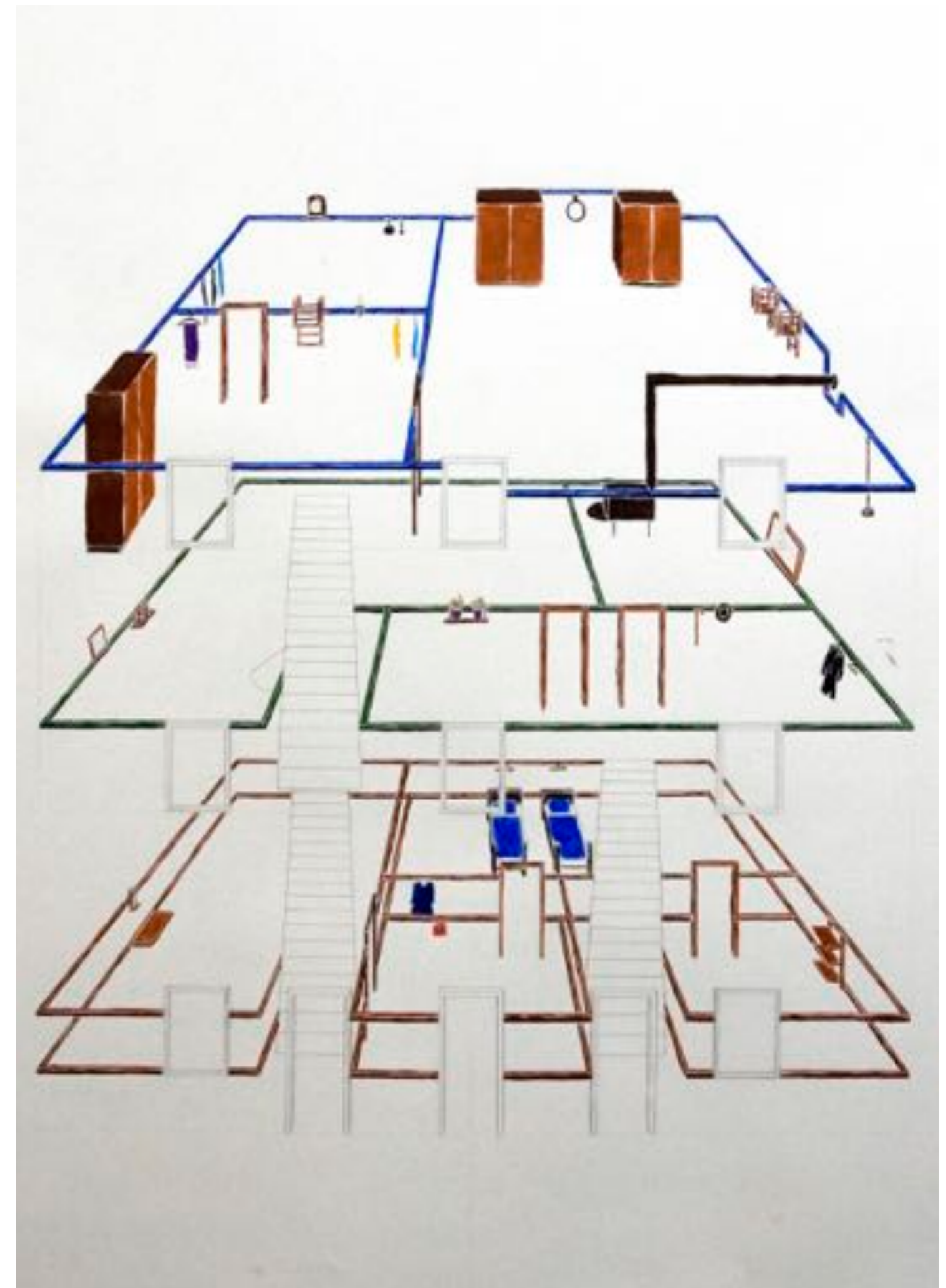





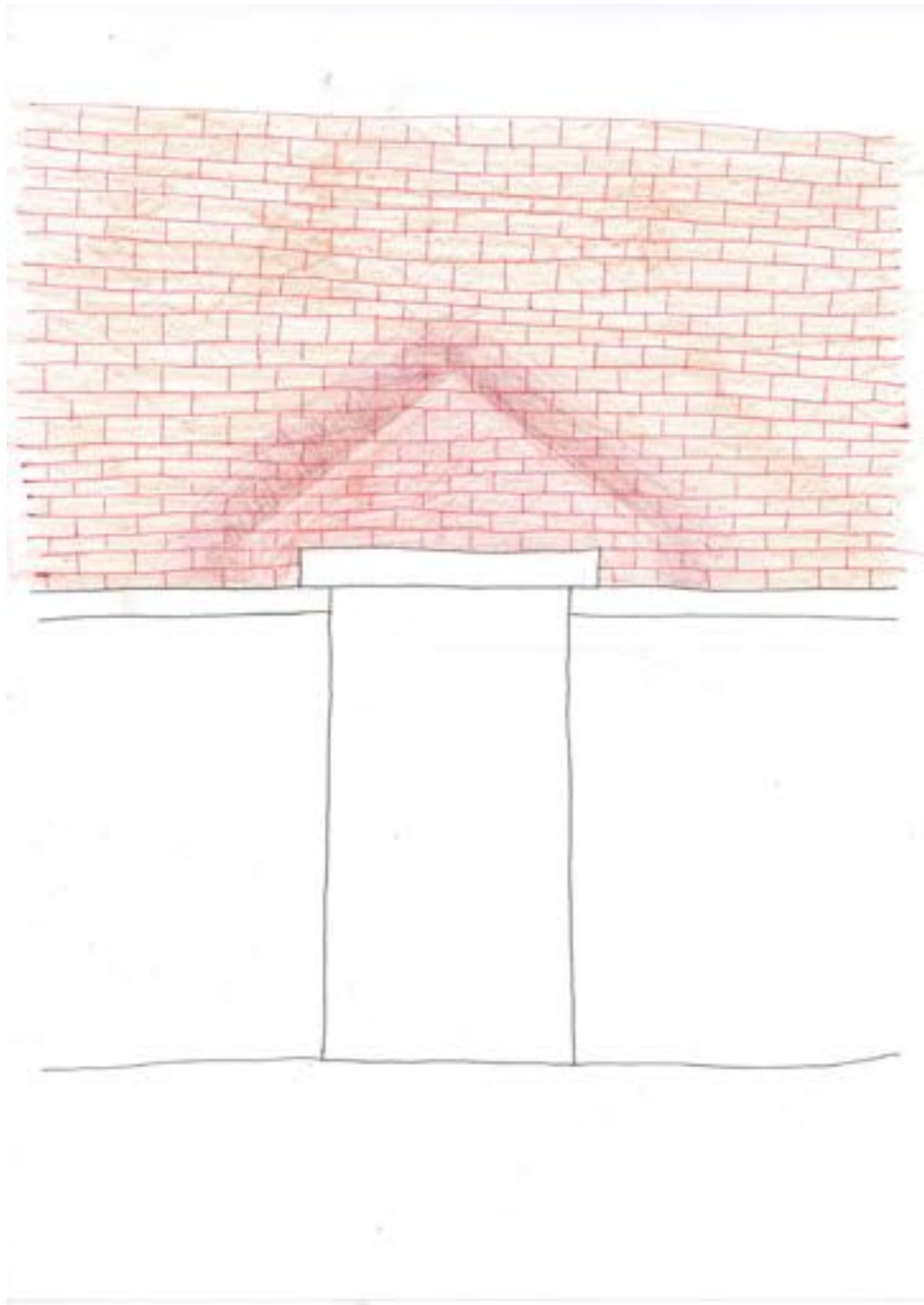

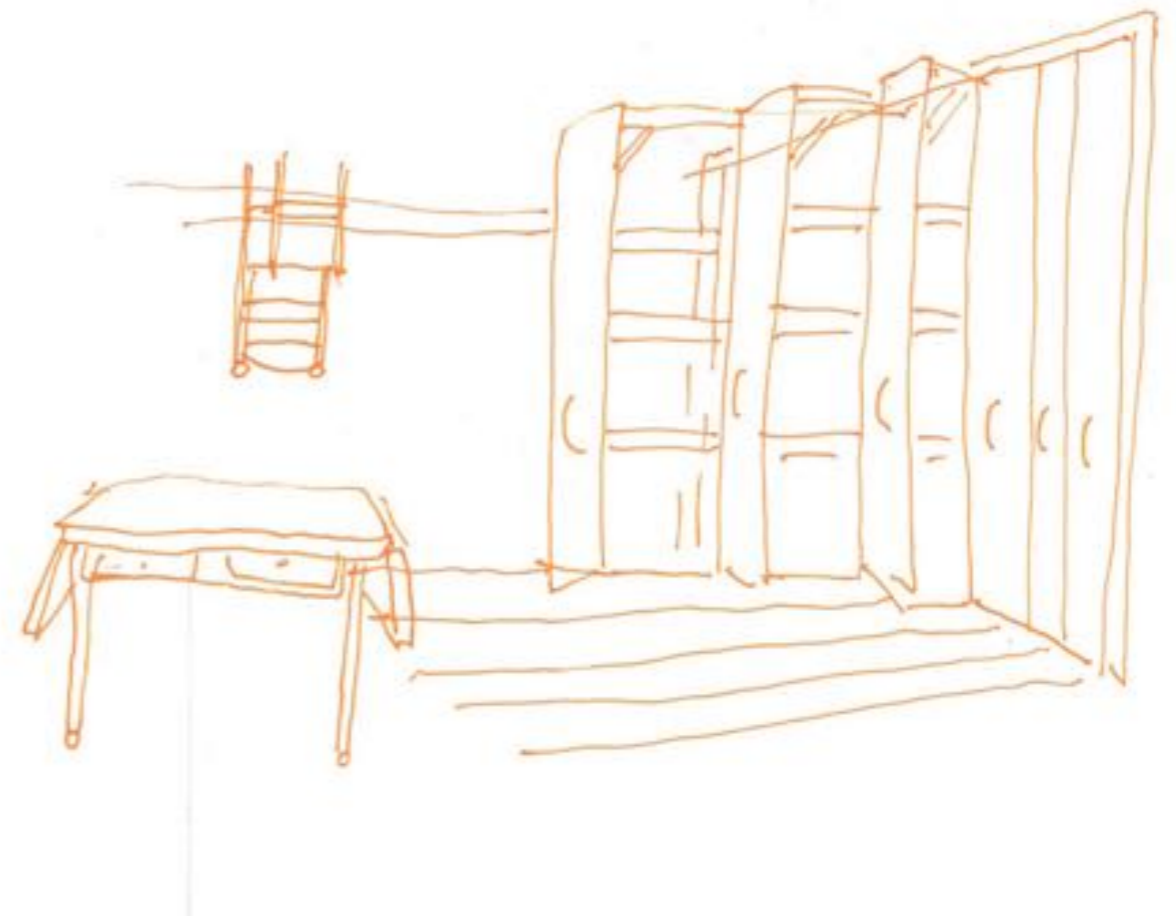

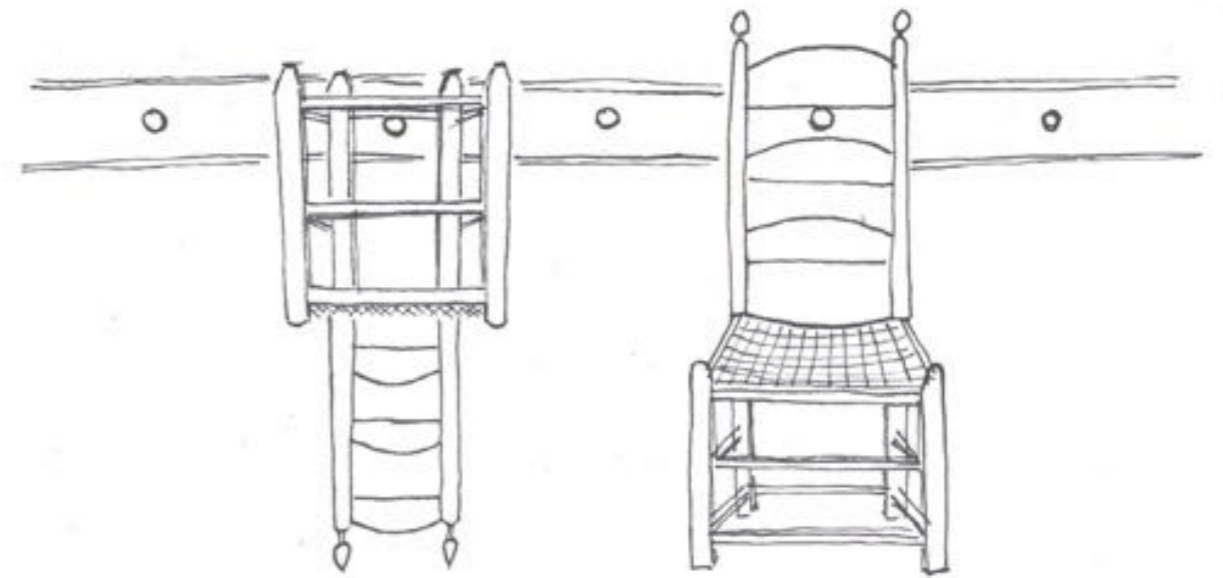

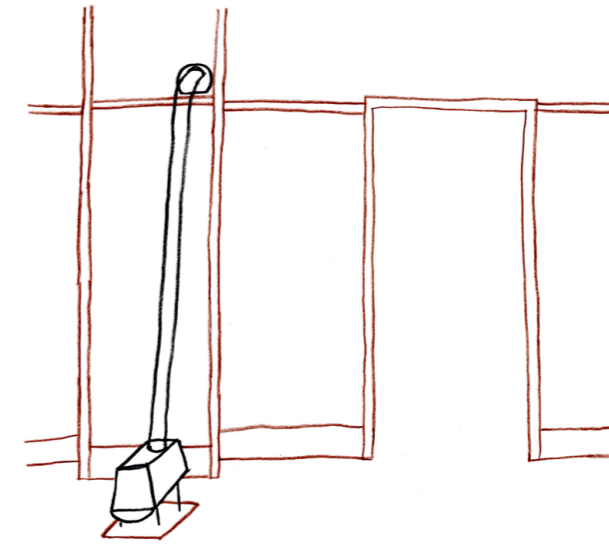

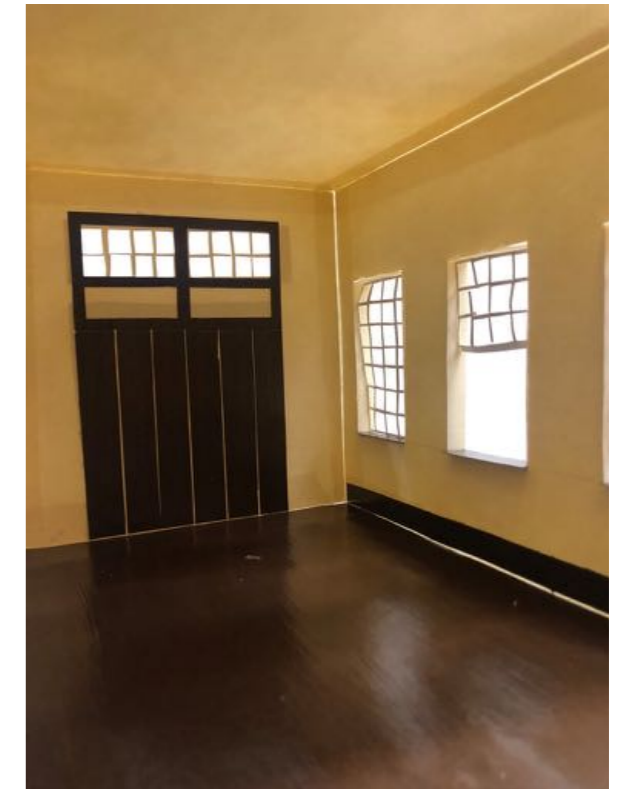

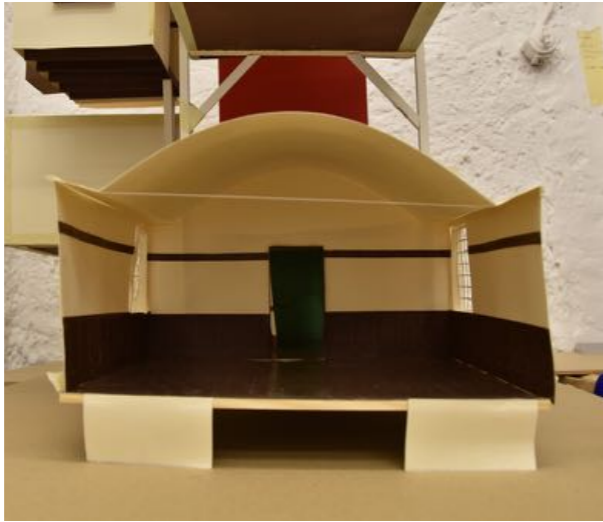

## Movement 2

### US in BE



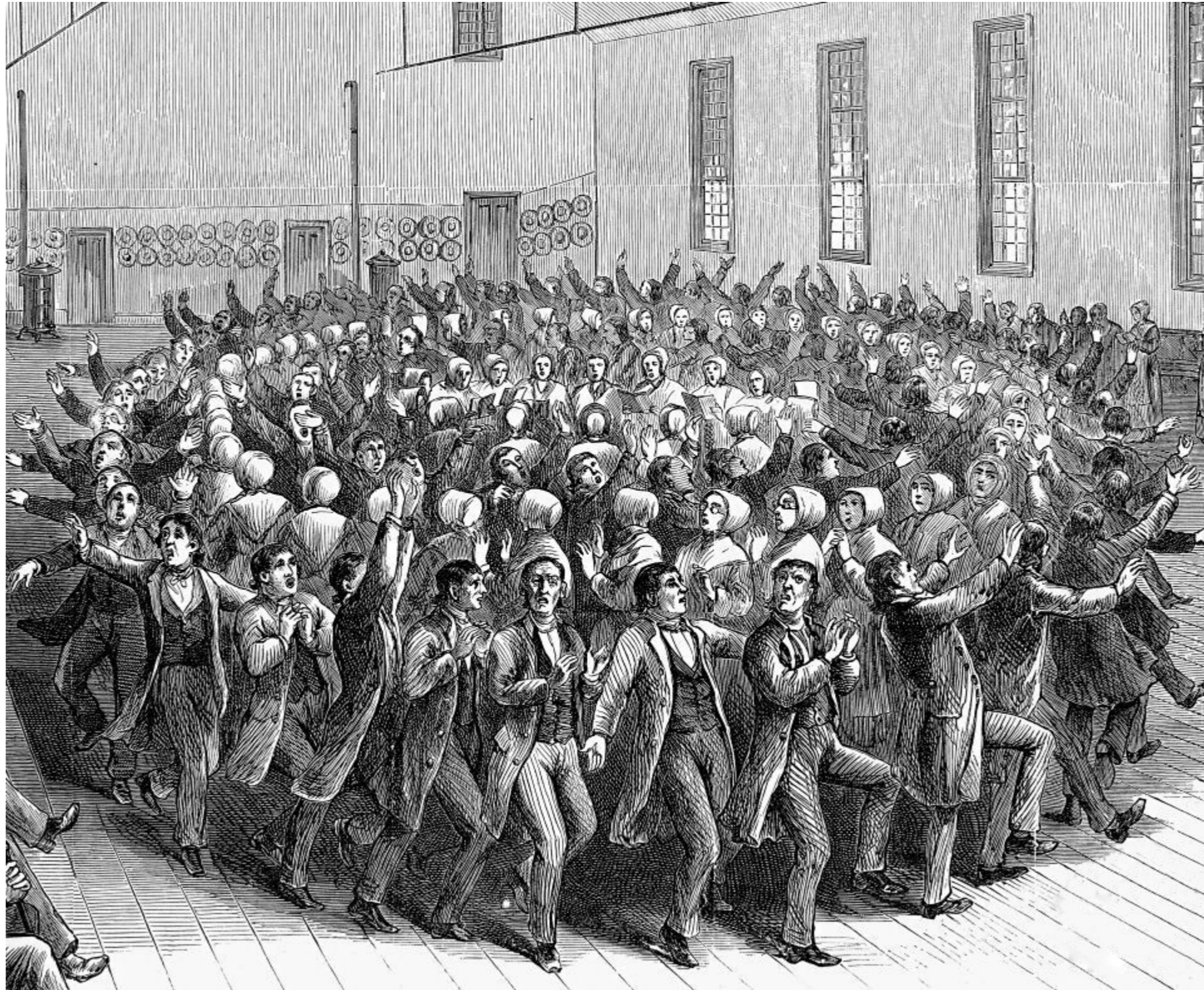



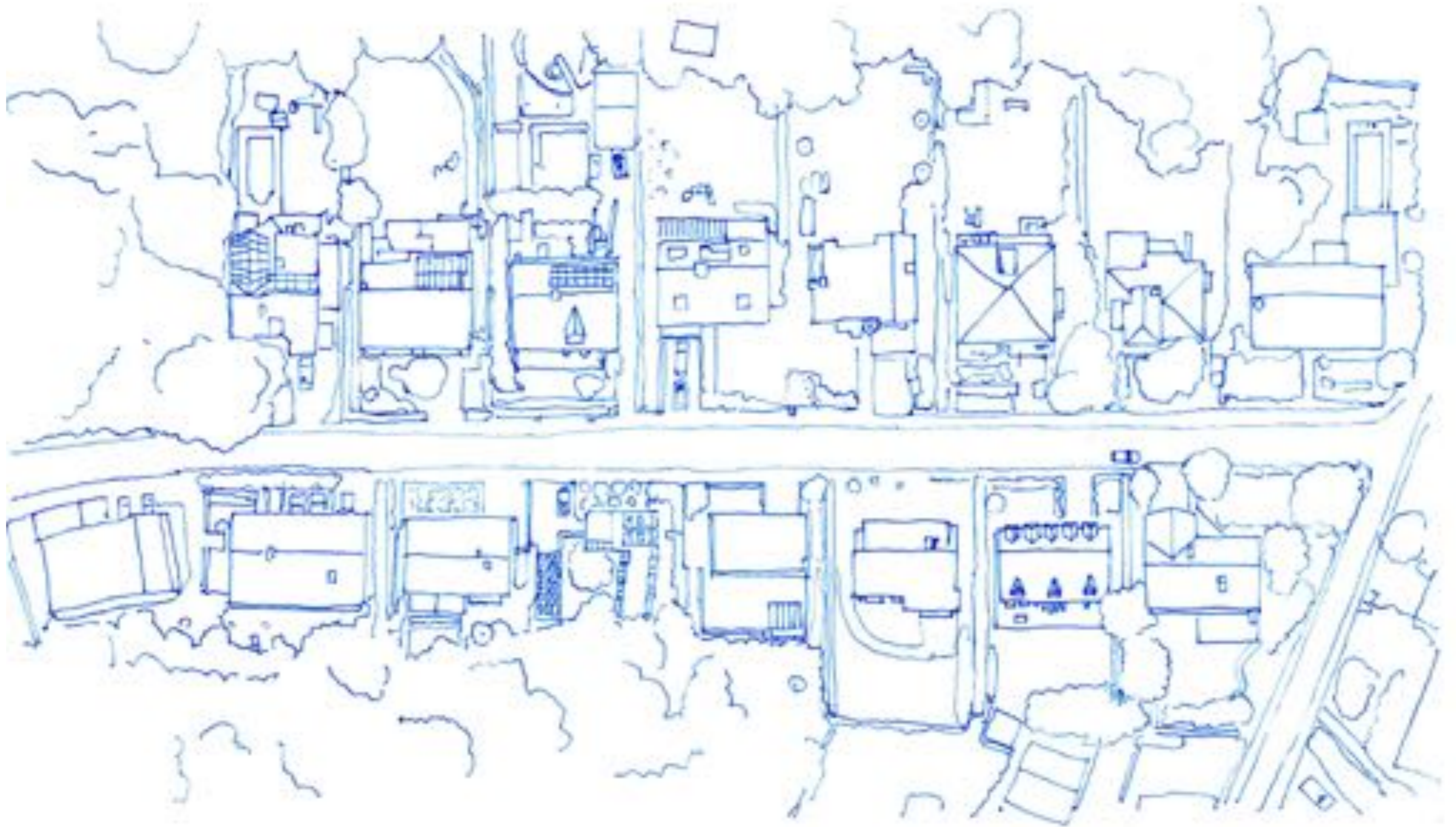

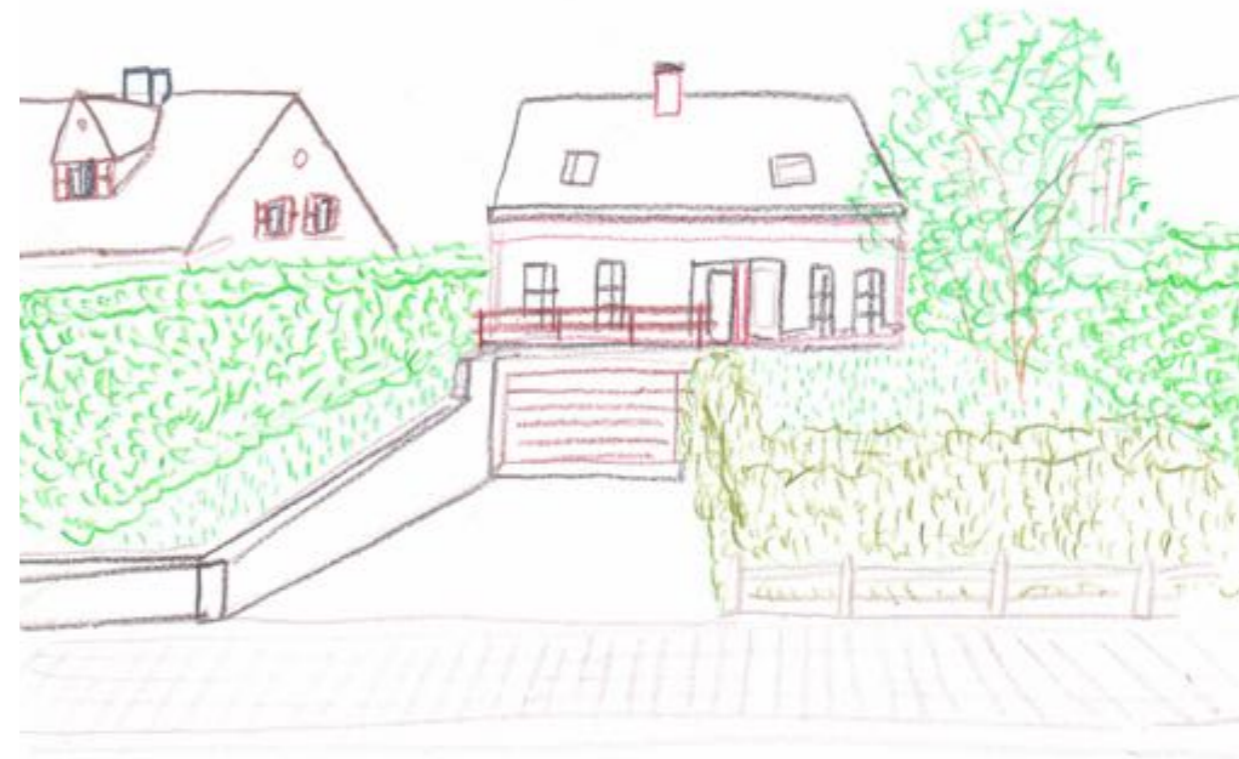





A CATALOGUE  
OF COMMUNAL  
INHABITWEENERS



# A Catalogue of Communal Inbetweeners

## Garden Shed Cafe

Drinking a cup of coffee in the shadow of the red oak - the hands still dirty from the potato digging - having a chat with the neighbor about the newest trends in the garden tool industry and looking down on the work you've just done.

## The Fire Temple

Grill a steak, trill a song - what needs to be explained more?

## Full Moon Tower

We use to climb up the ladder with a good old bottle of red wine - watching out not to fall down - on warm summer nights, watch the moon for hours and tell each other stories from our memories.

## The Wooden Tent

Our children love to play hide and seek - sometimes I get involved involuntarily. At least I always know where to find them.

## Petanque Streak

Throwing balls, drinking beers and making fun of each other.

## Stage

The best space to strengthen your self-confidence. Sometimes there's a cute violin concert of one of the children, sometimes it's used by the elder ones to speak out their minds or to just tell a joke.

## Bus Stop

As most of us don't have a car - bad pollution for our gardens - it's indispensable to have a bus stop, especially when it drives through the street anyway.

## Bench

Most used by Mark, he loves sitting there for hours and just watch. Why do you have to sit in your backyard when there's so much more going on in front of the house?

## Lantern

The lantern never fails to guide dizzy people home after a hard night at their neighbor's barbecue party.

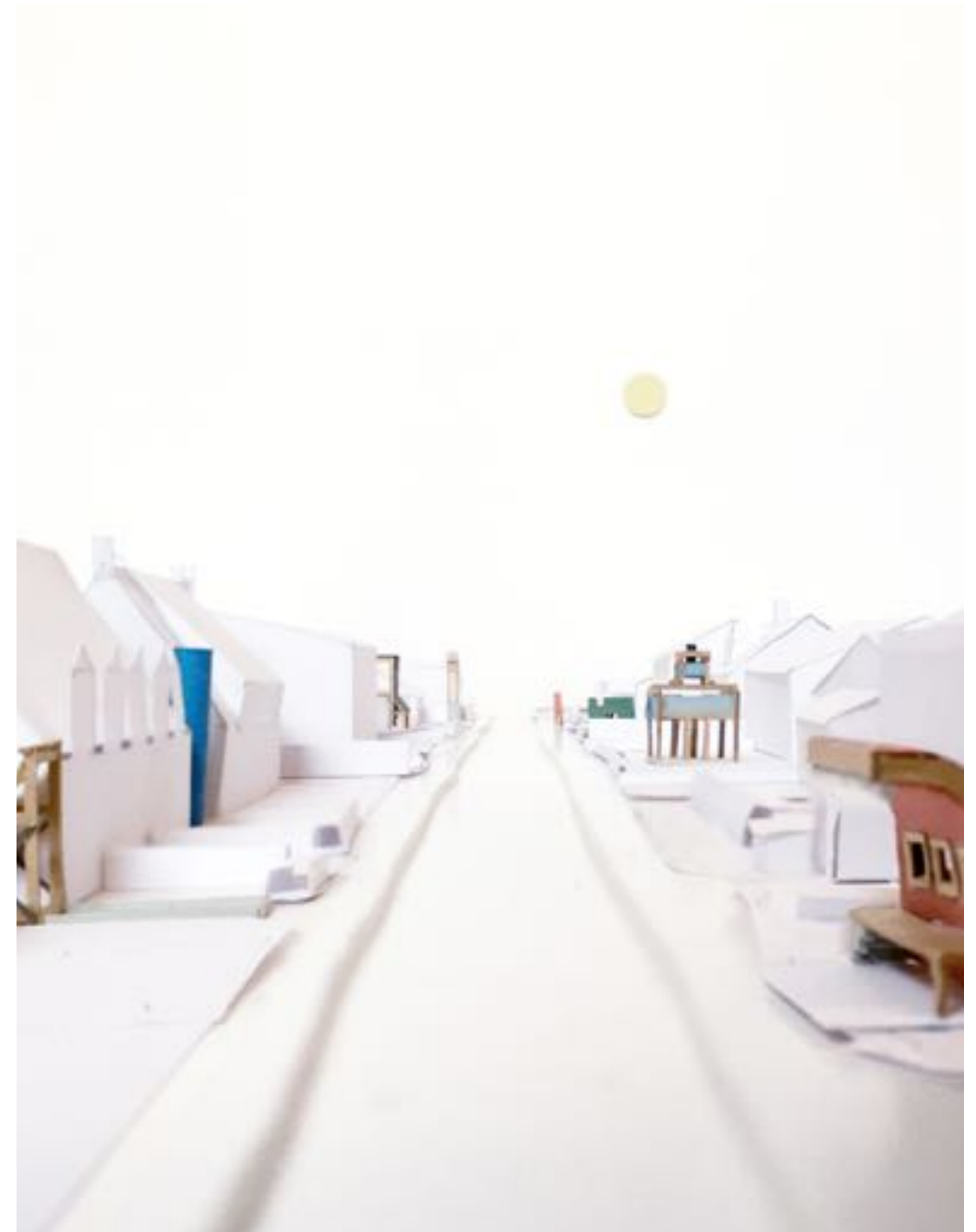





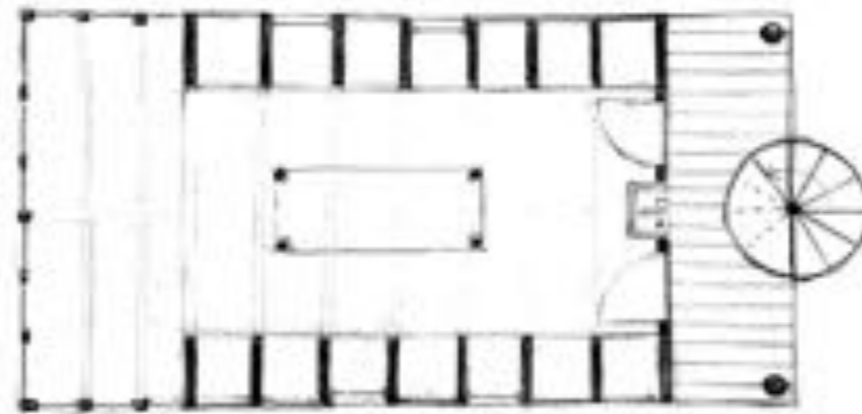
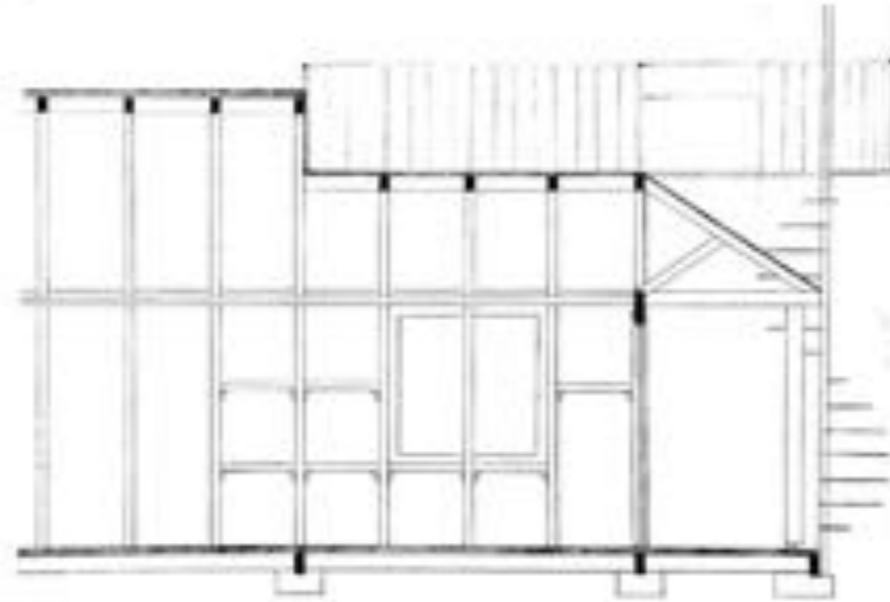



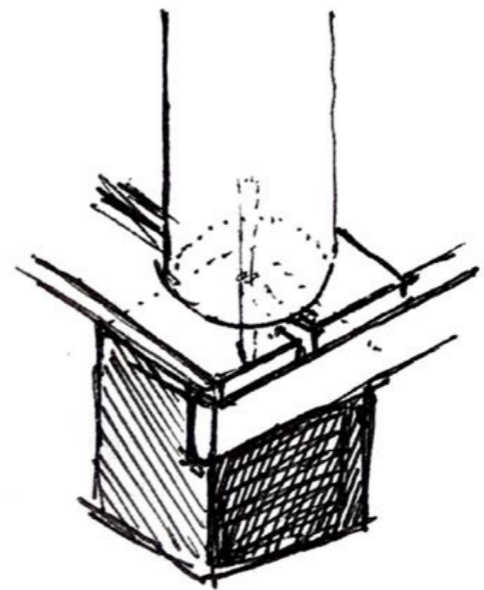
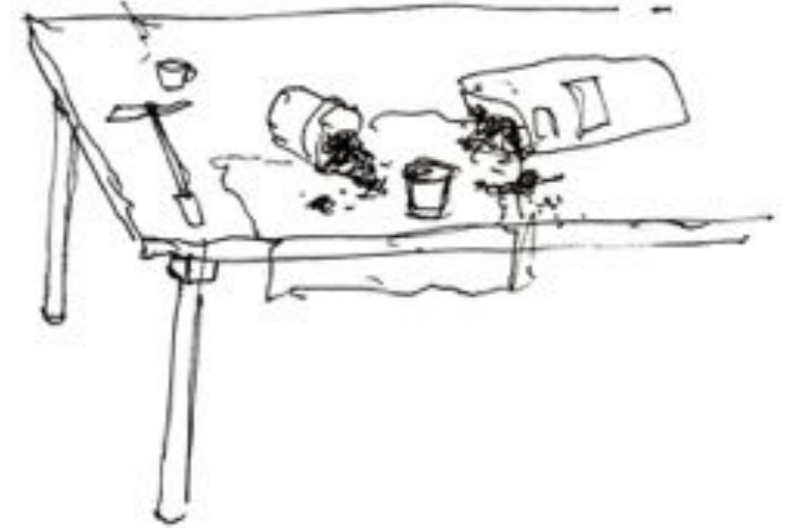
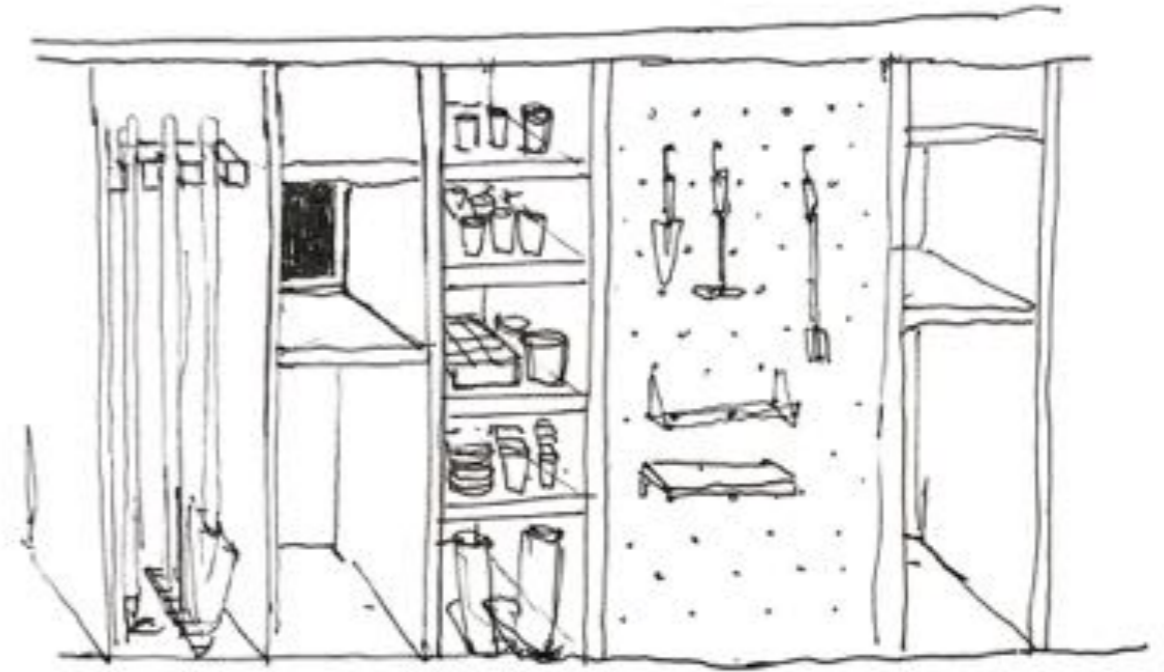
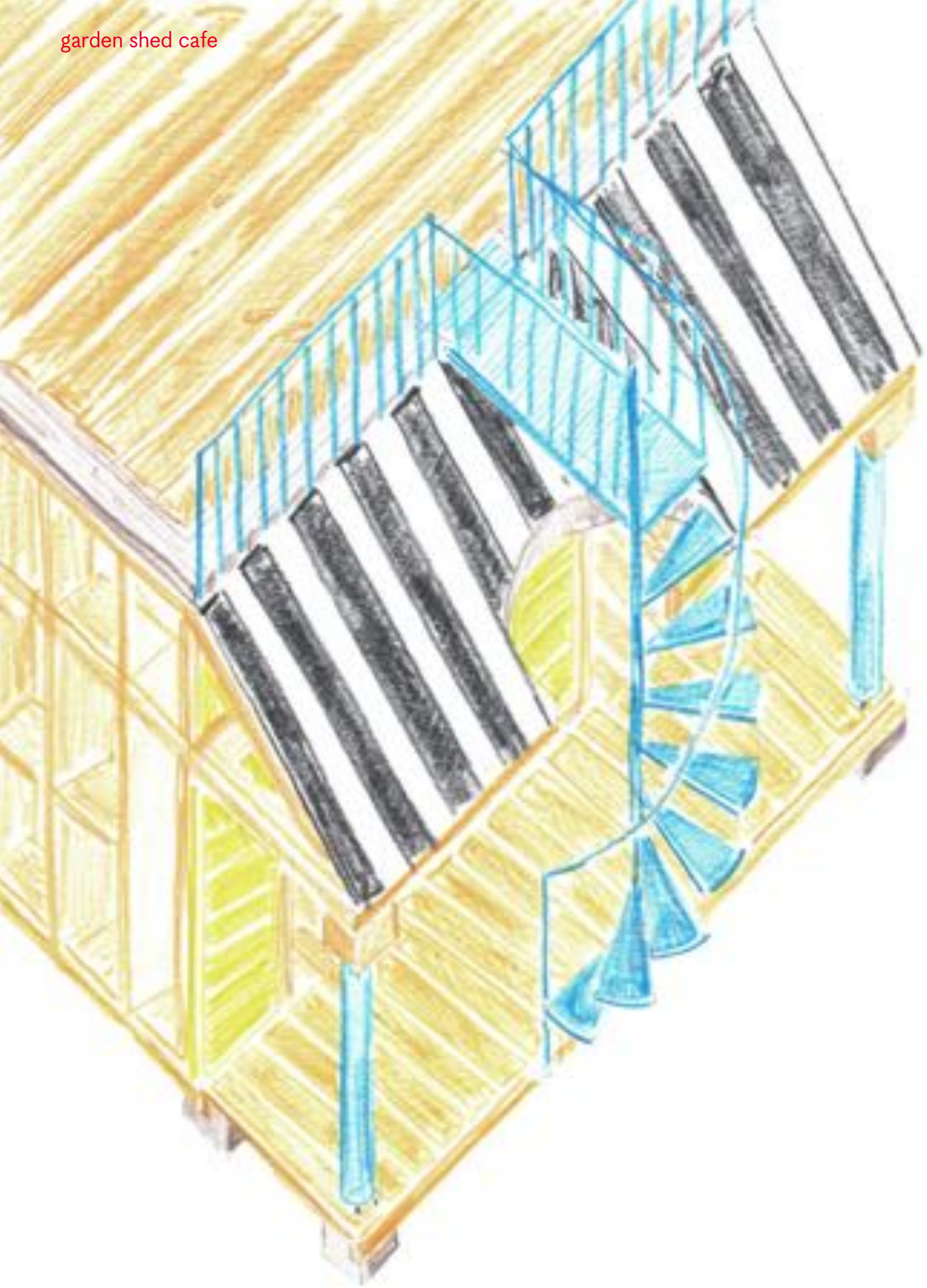



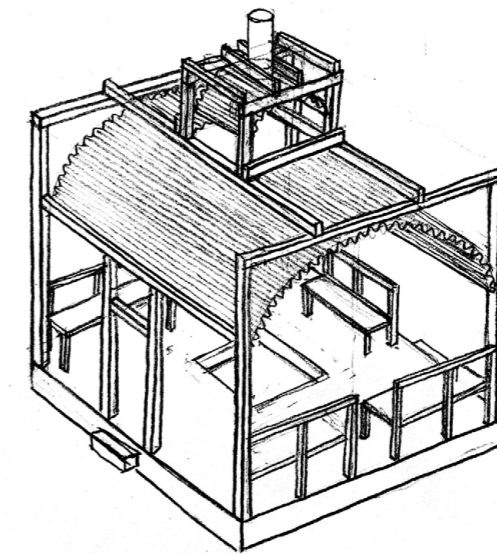
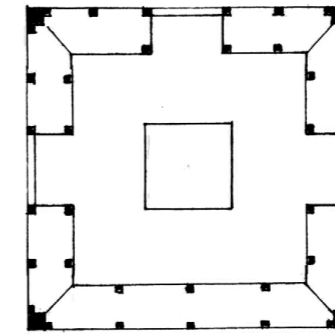
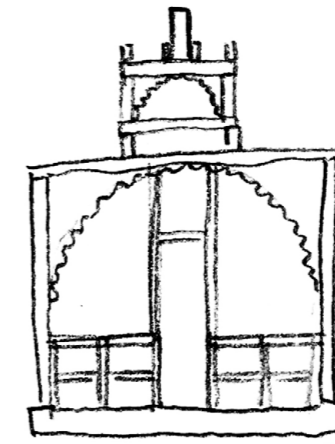
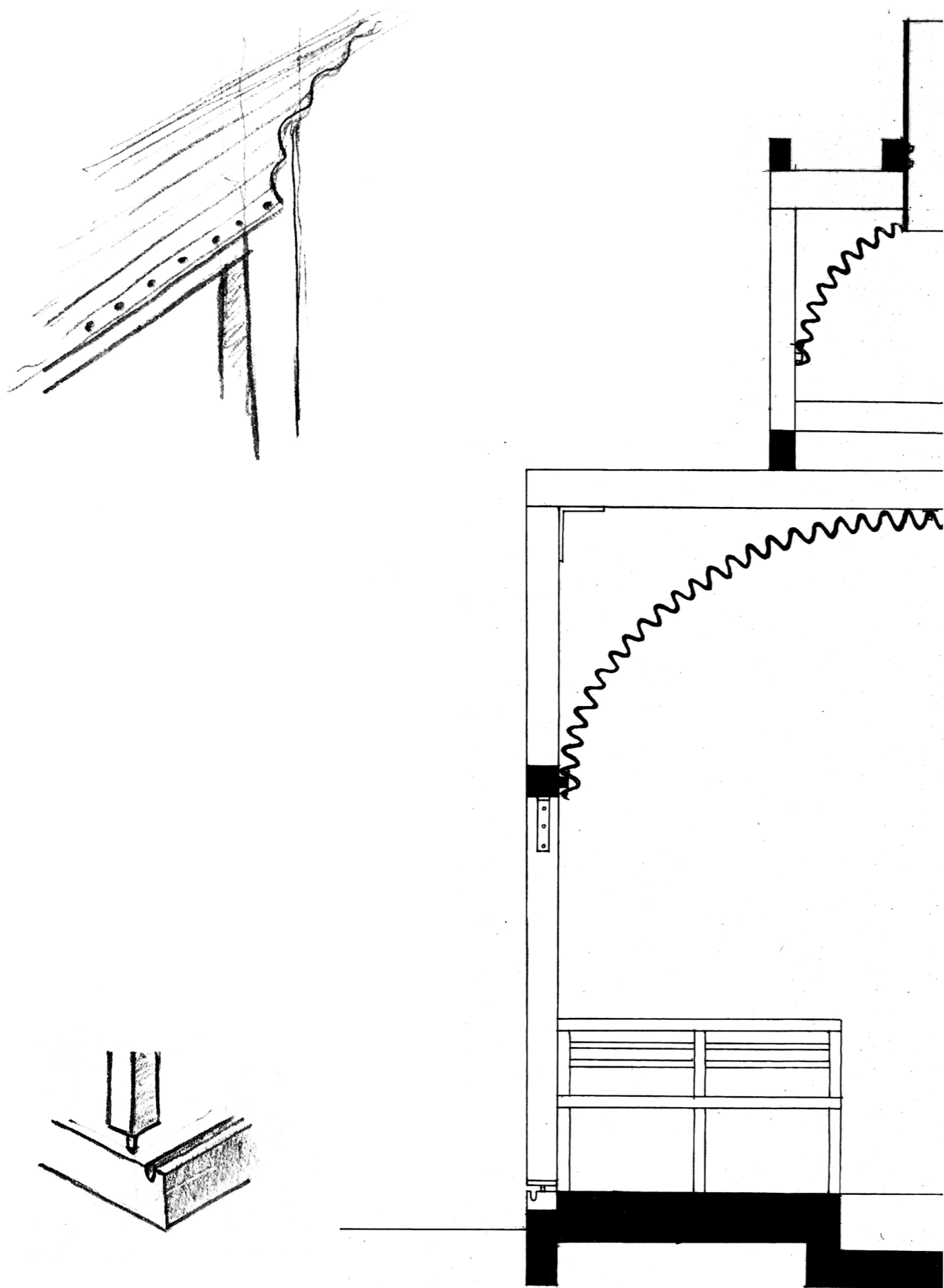

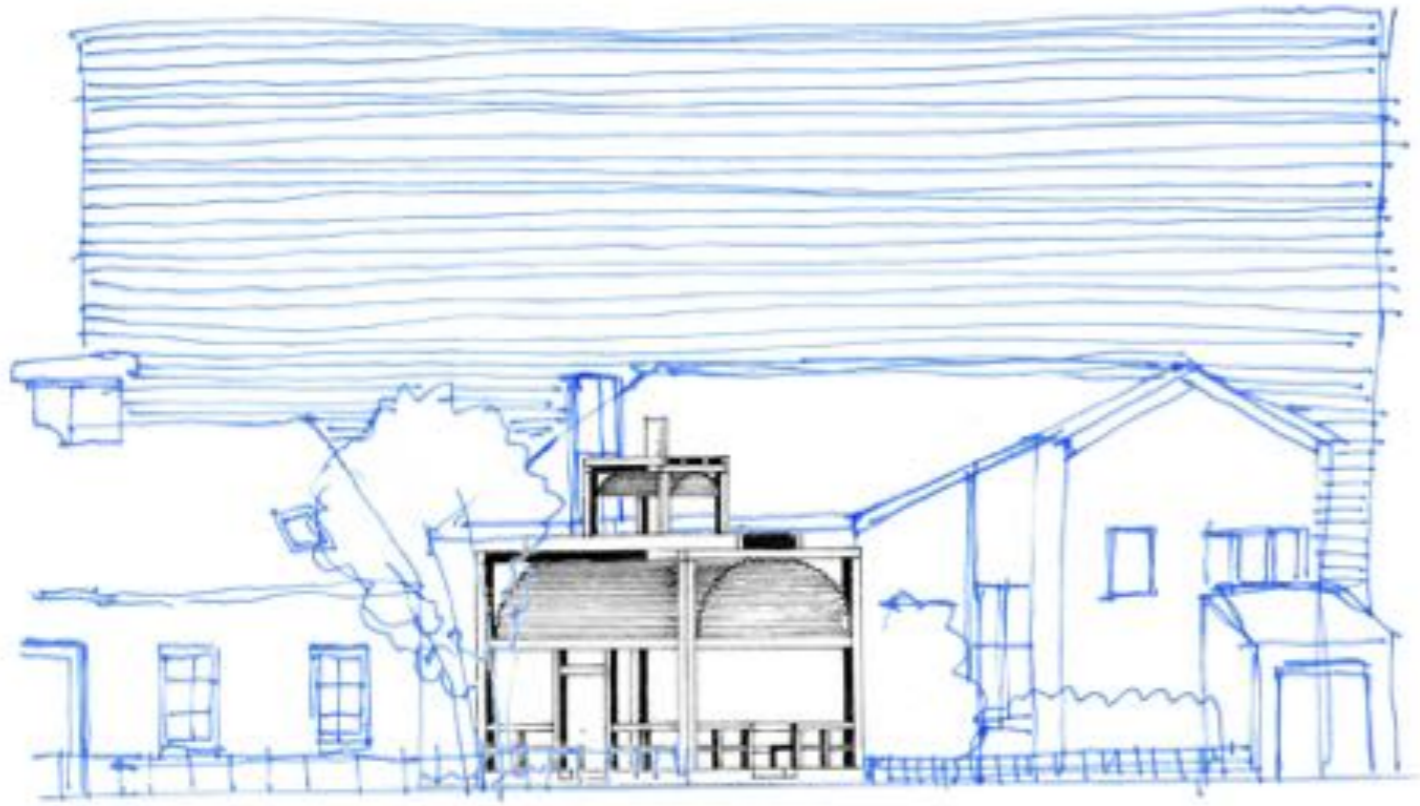



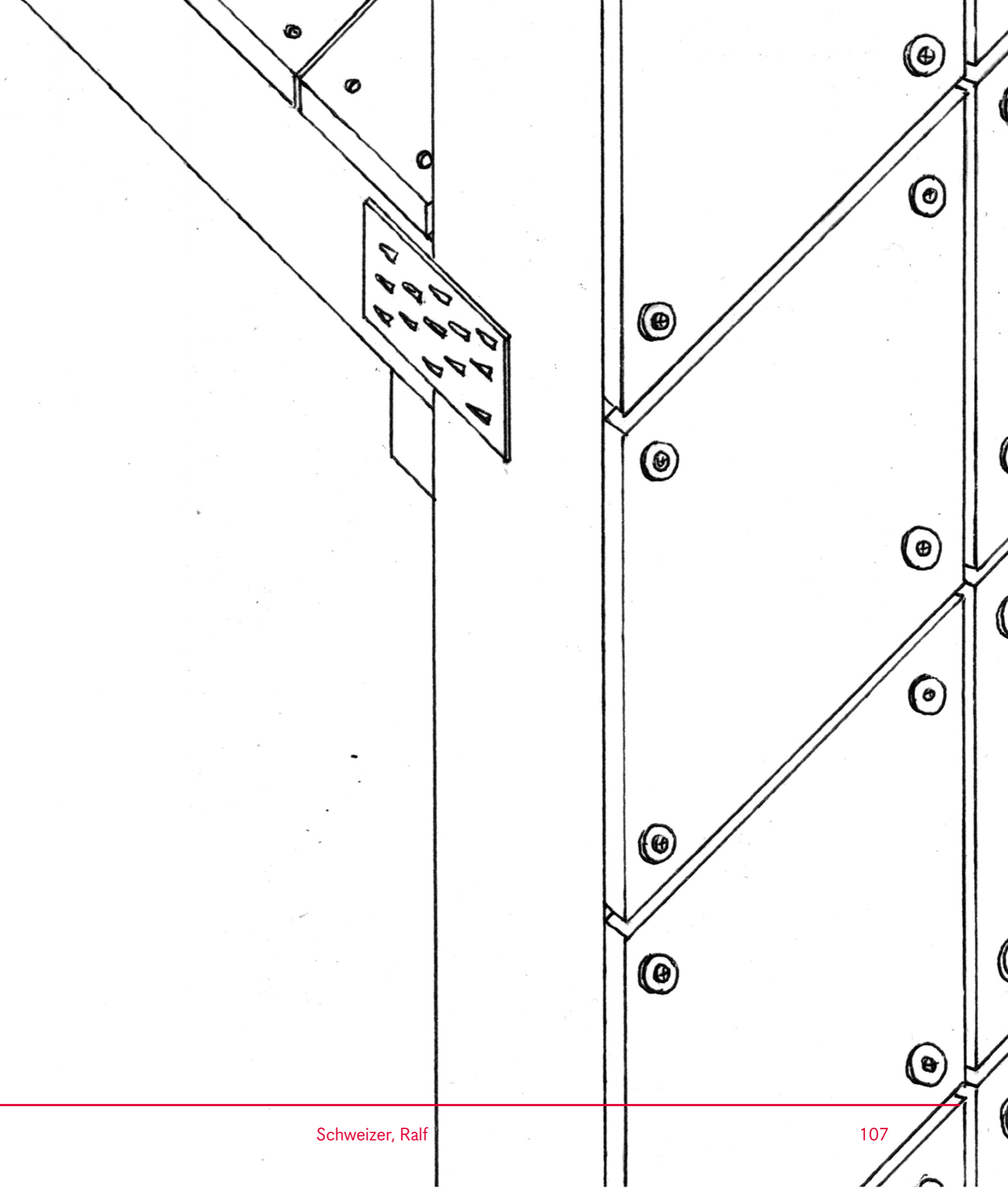
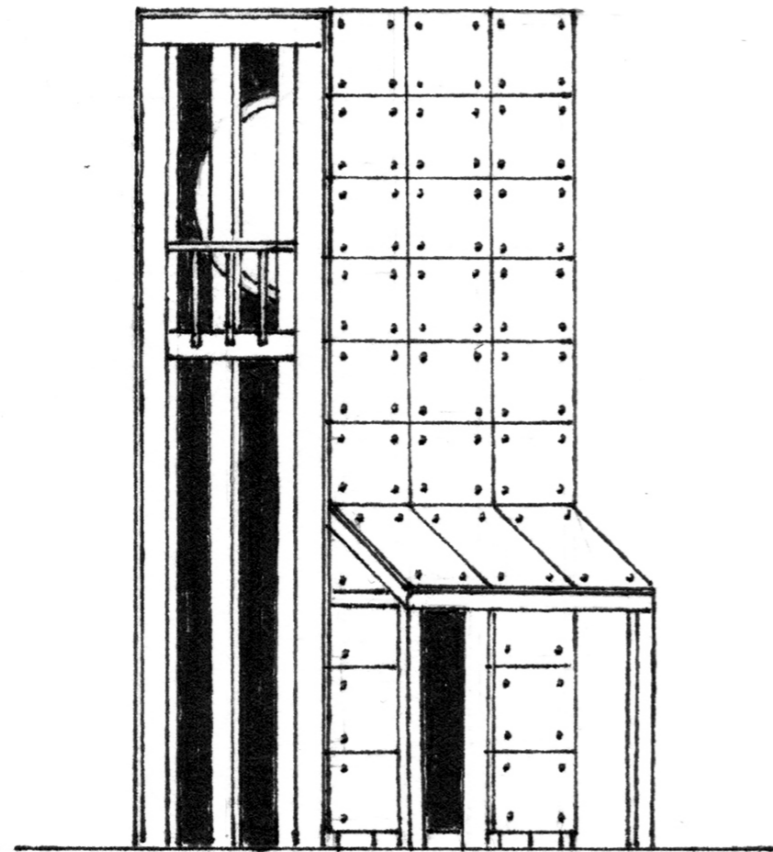

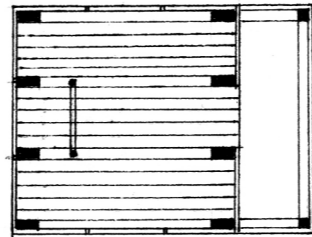
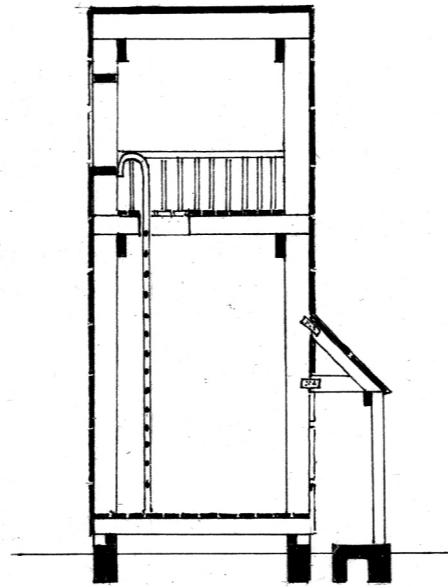





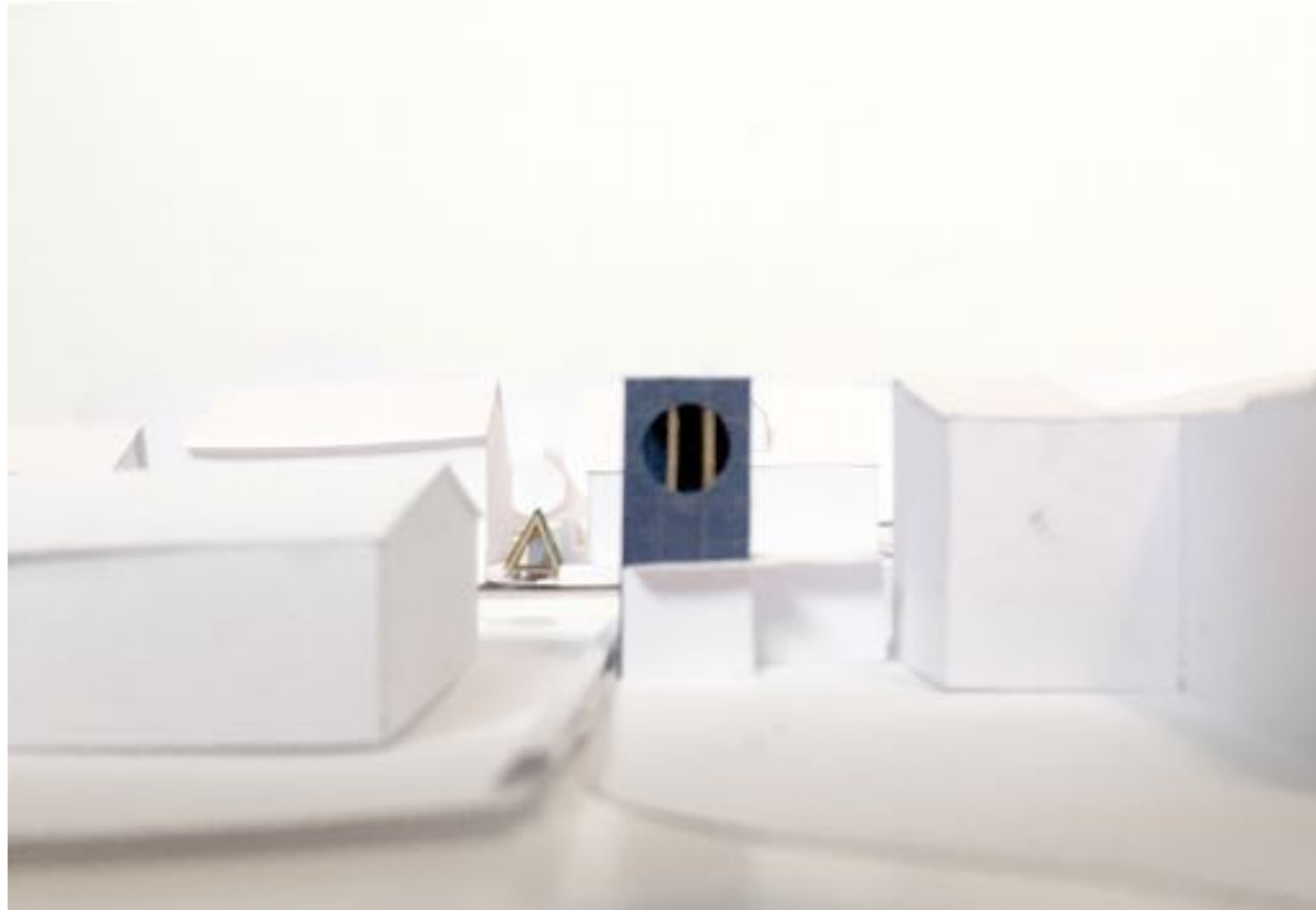

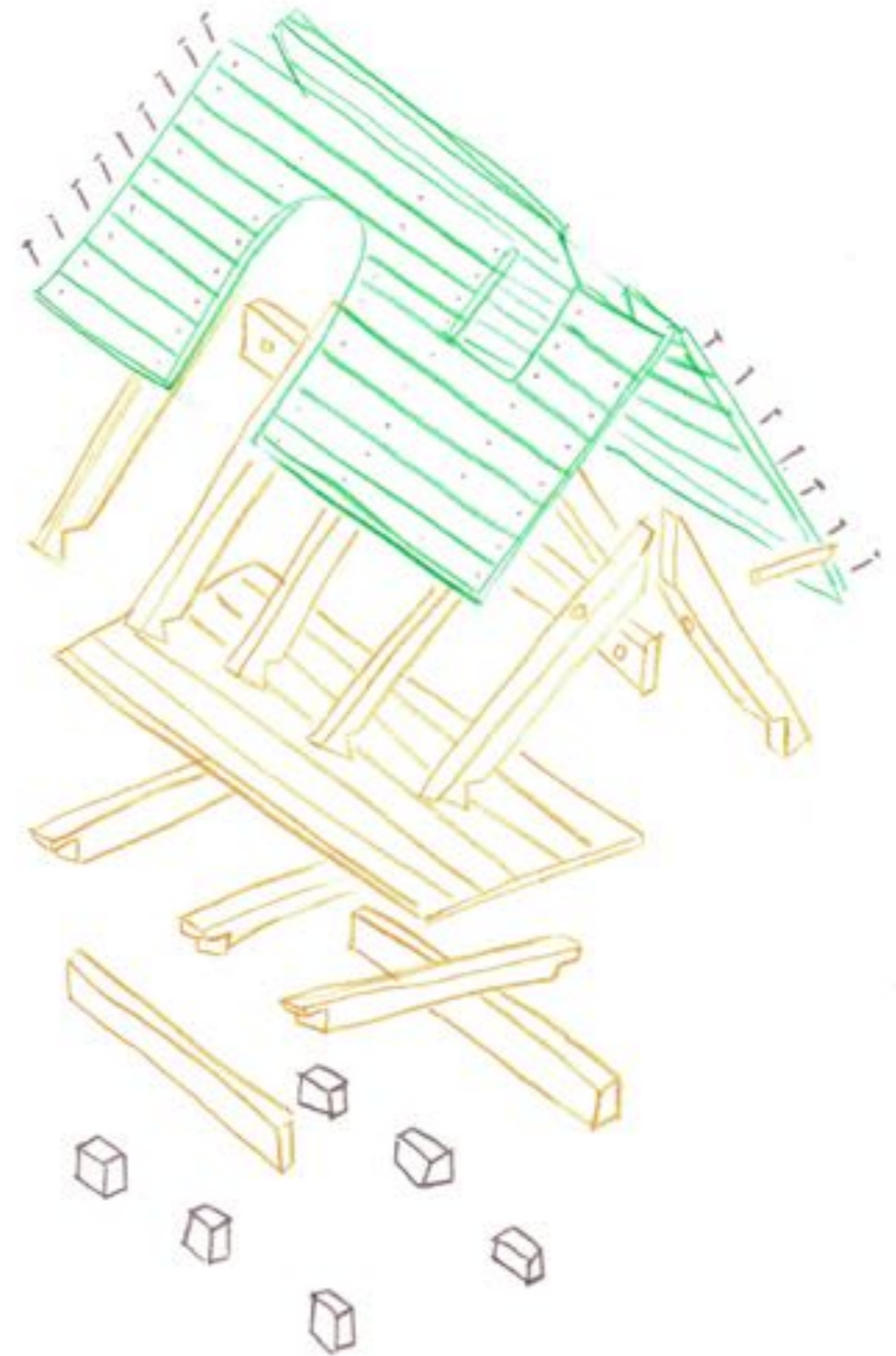

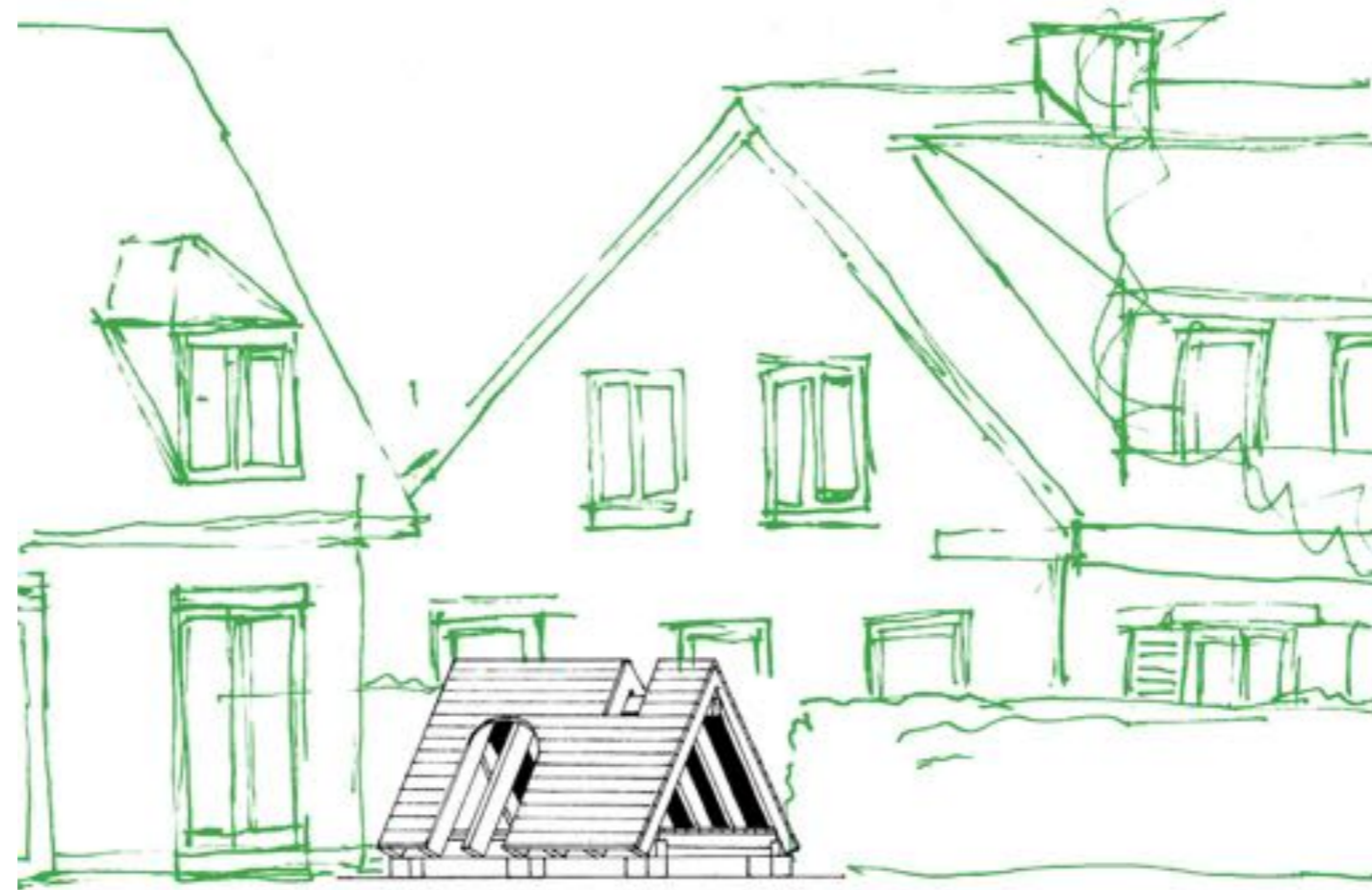



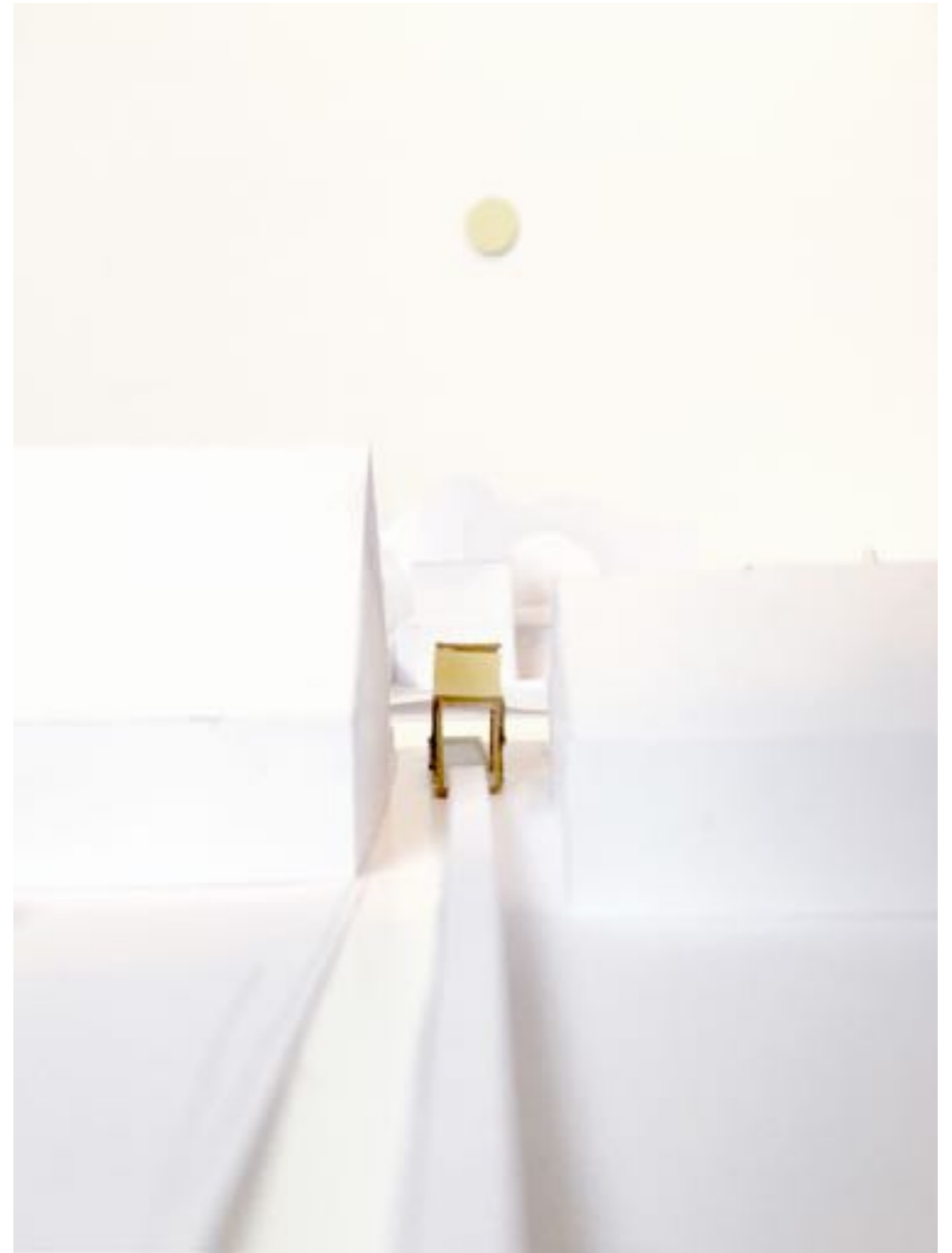

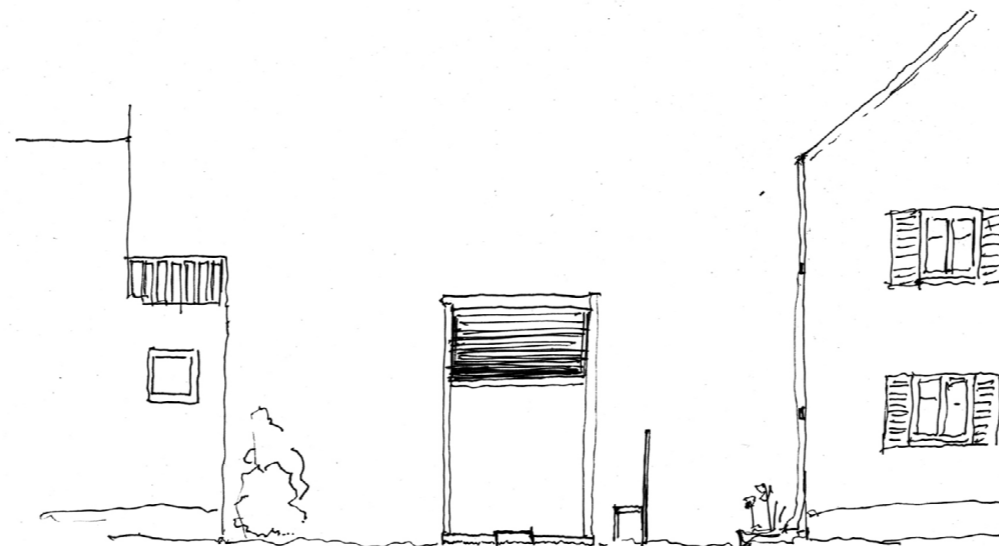
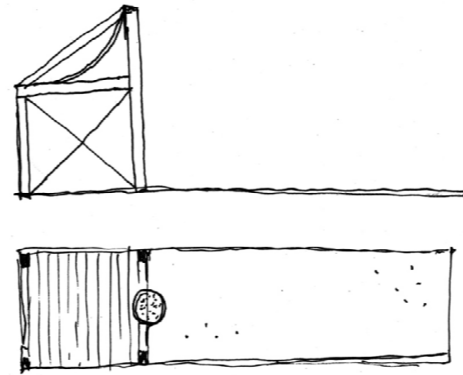
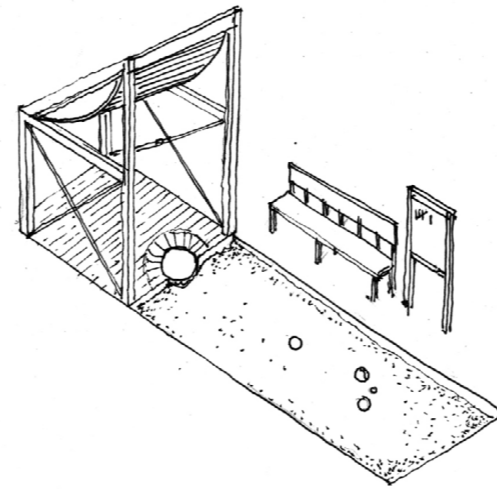







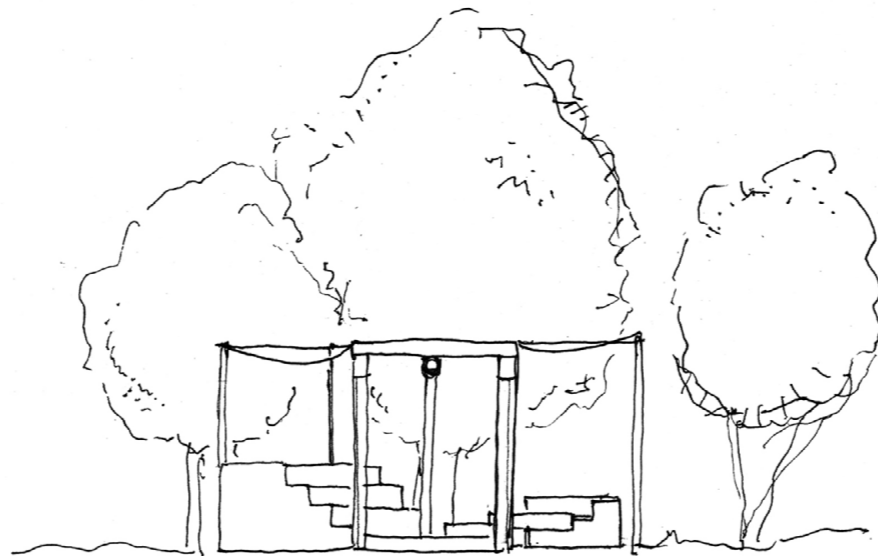
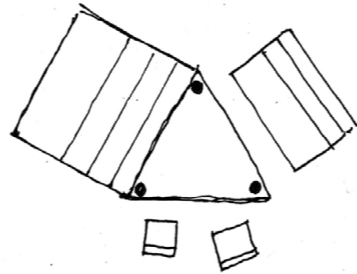
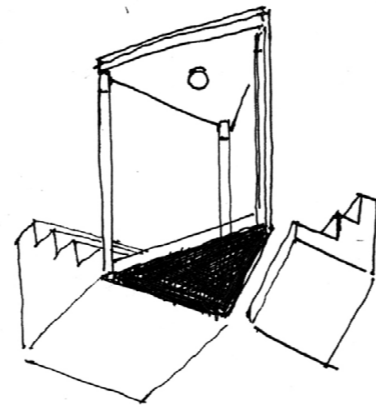

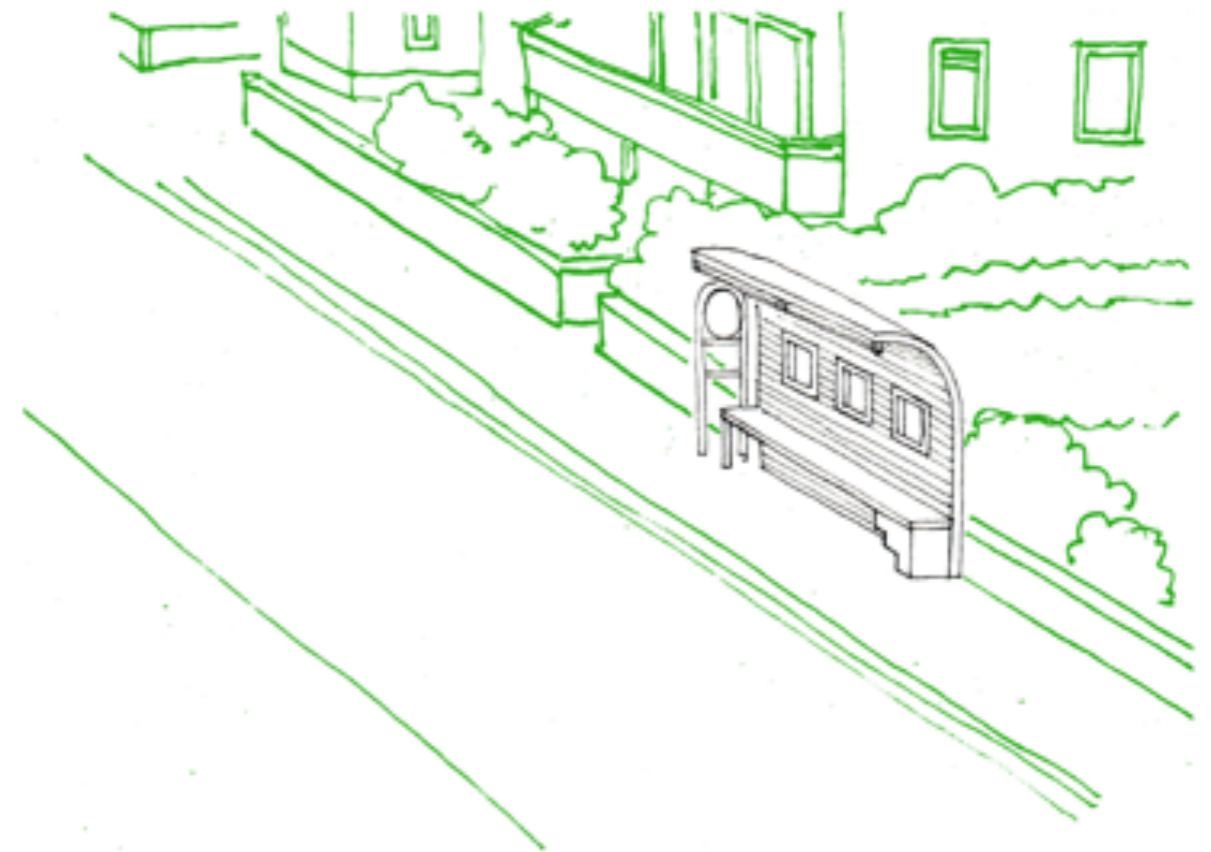

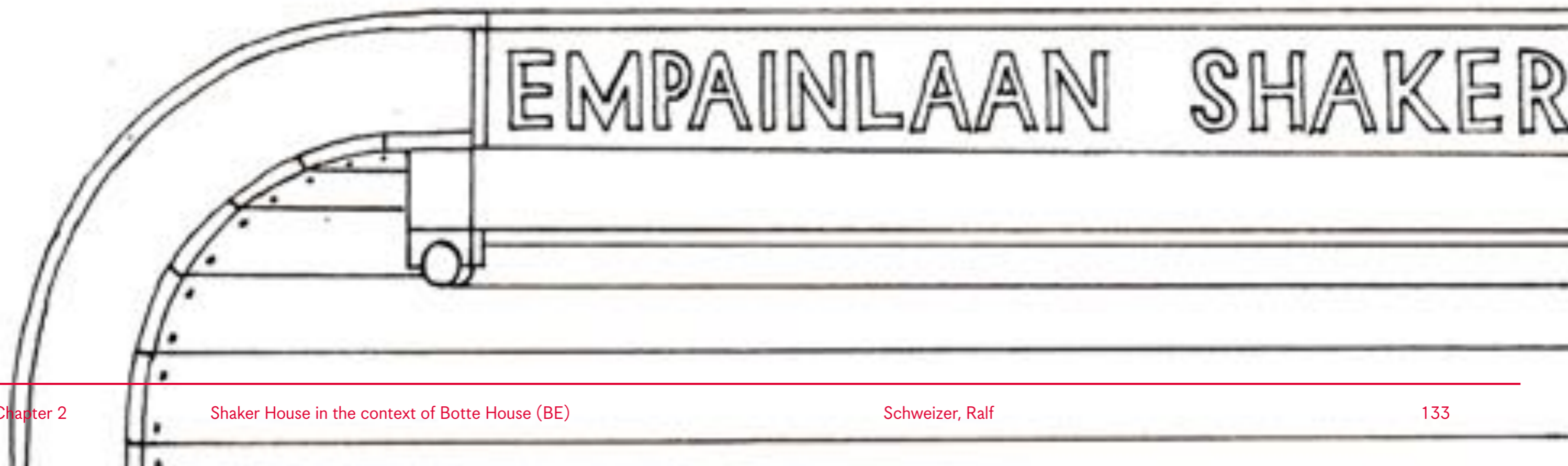
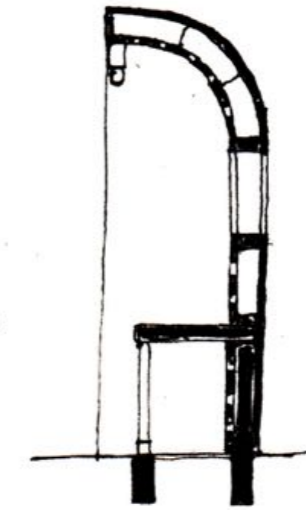



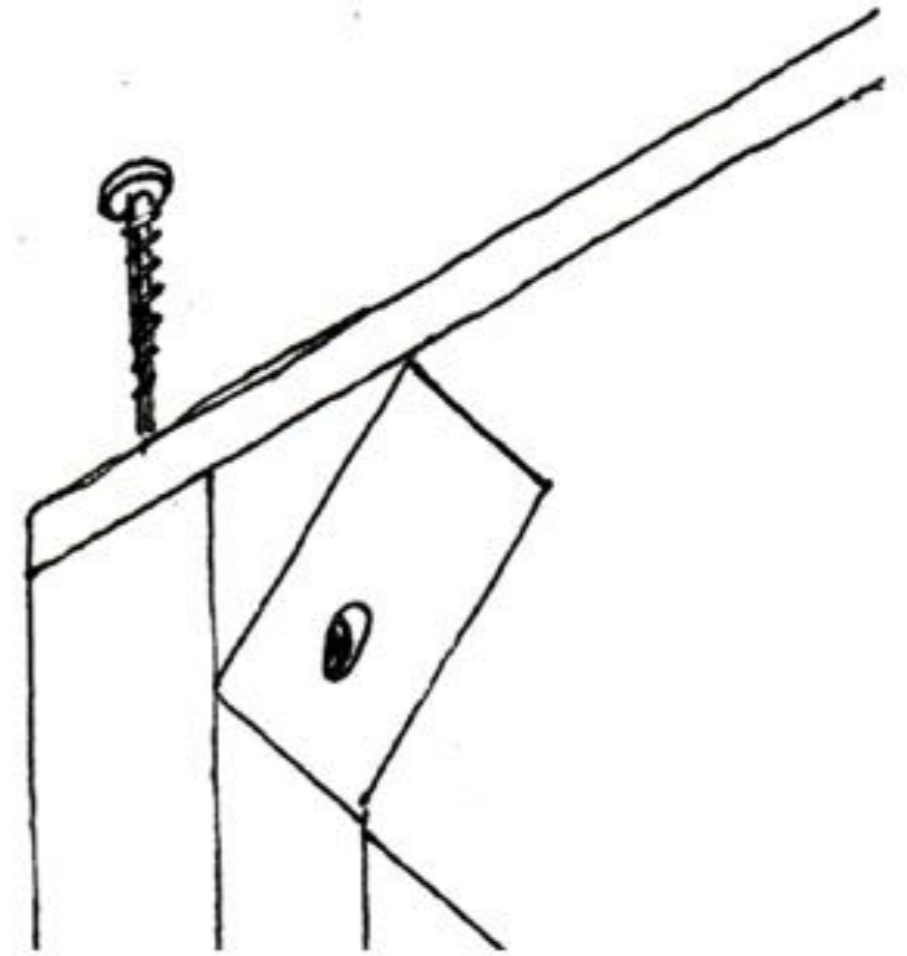
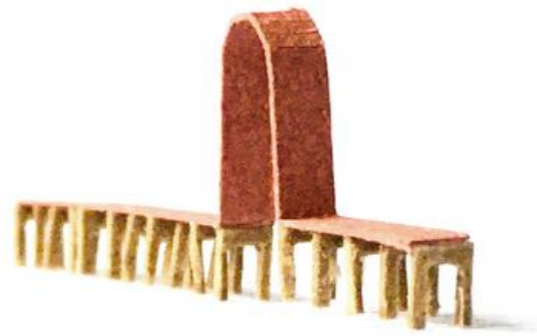

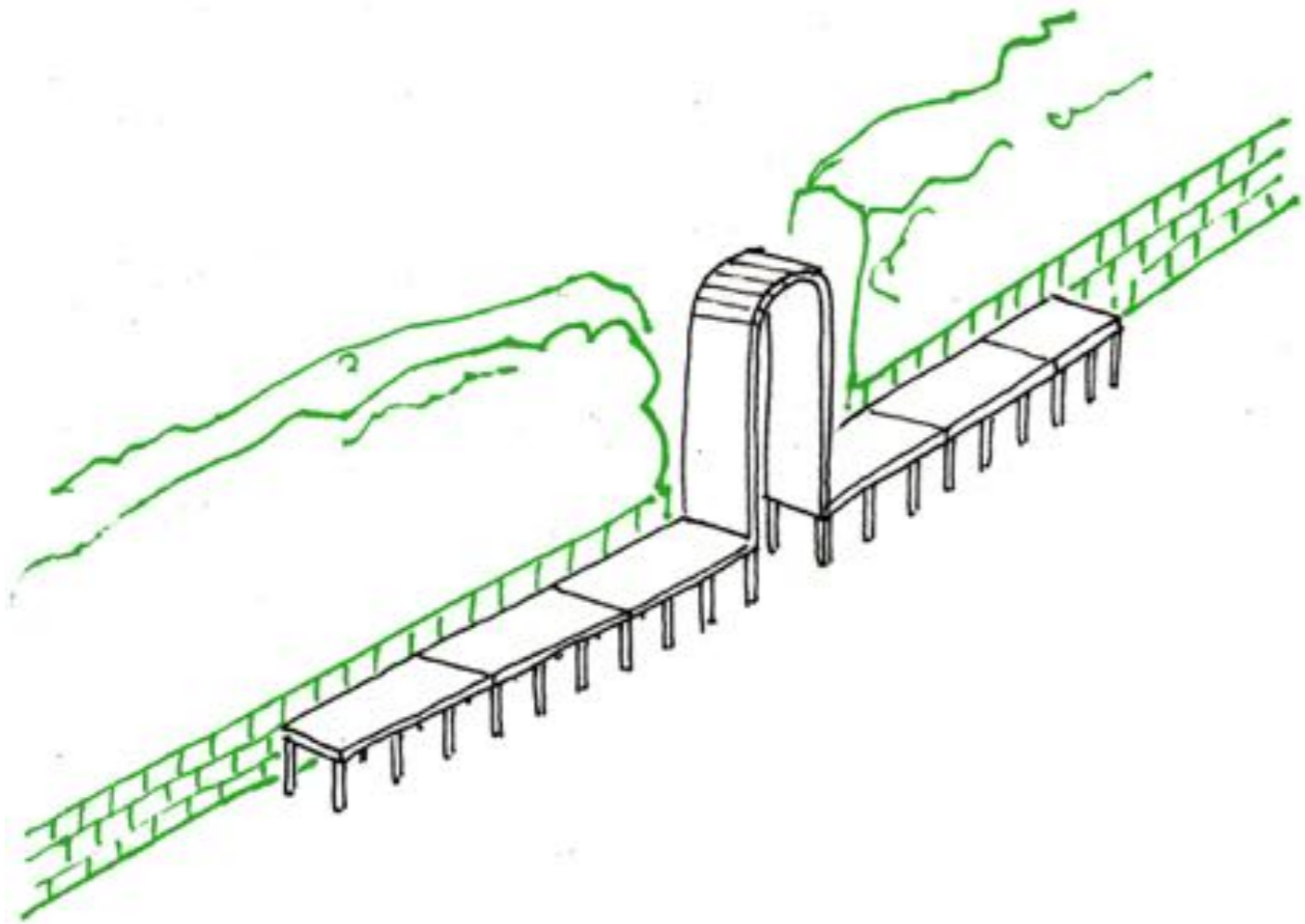

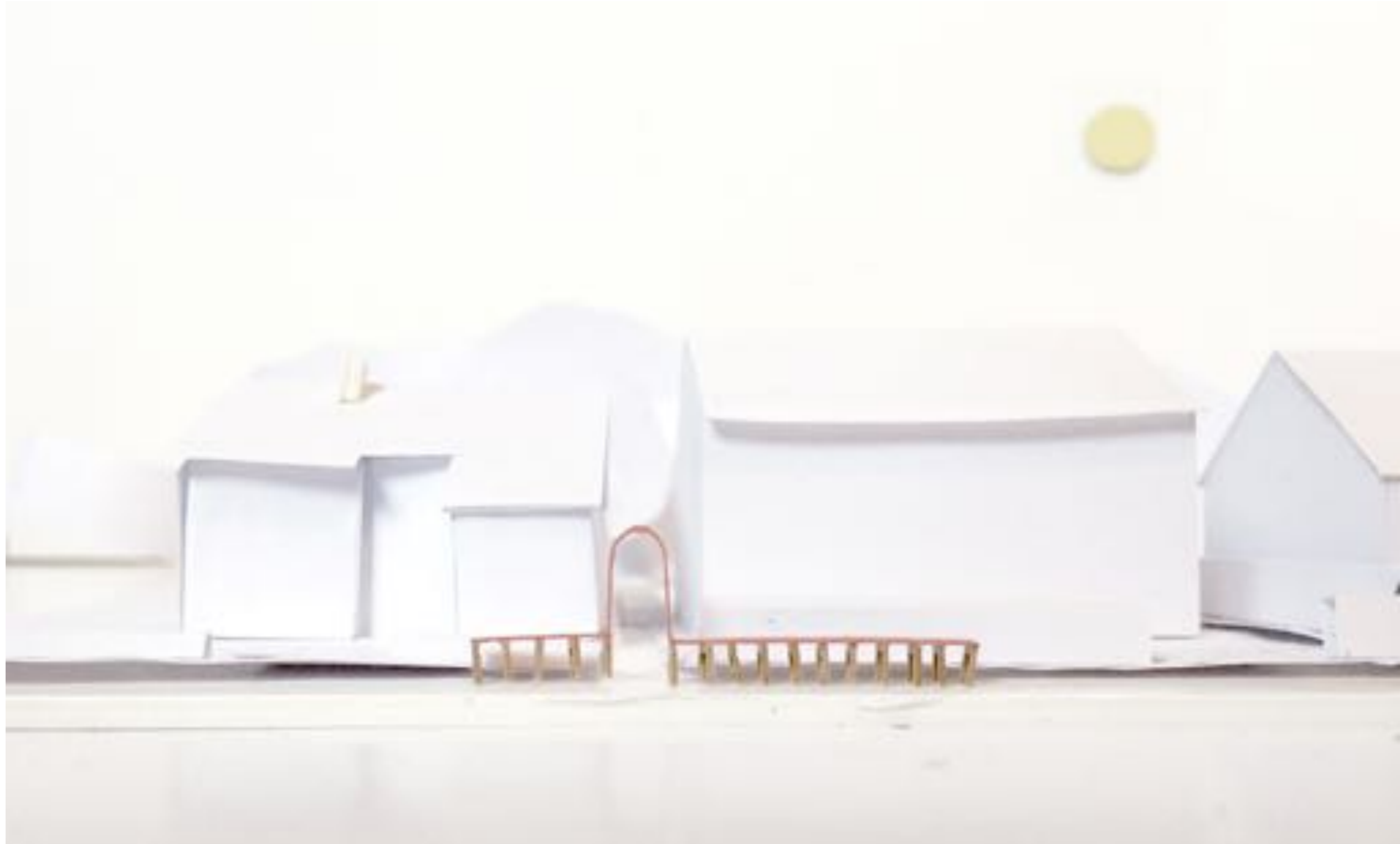

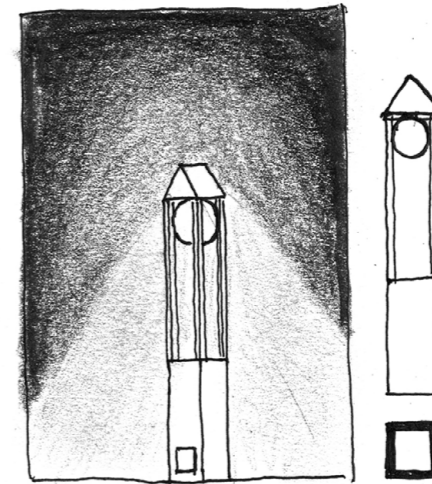
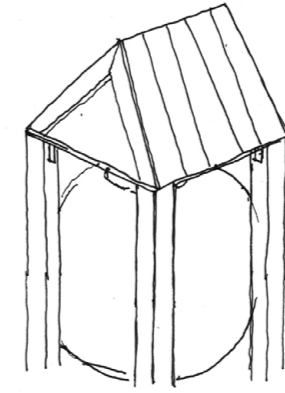



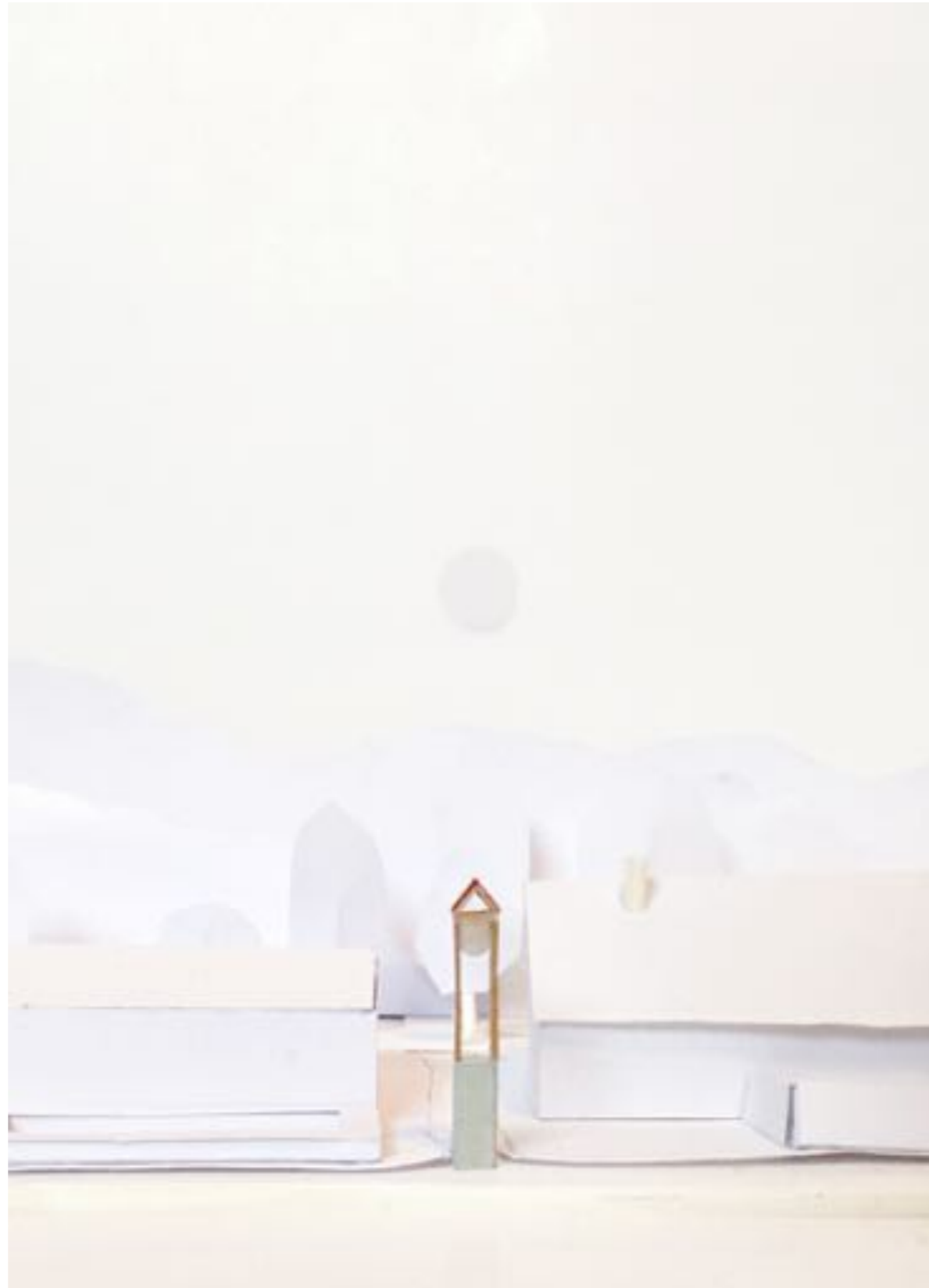

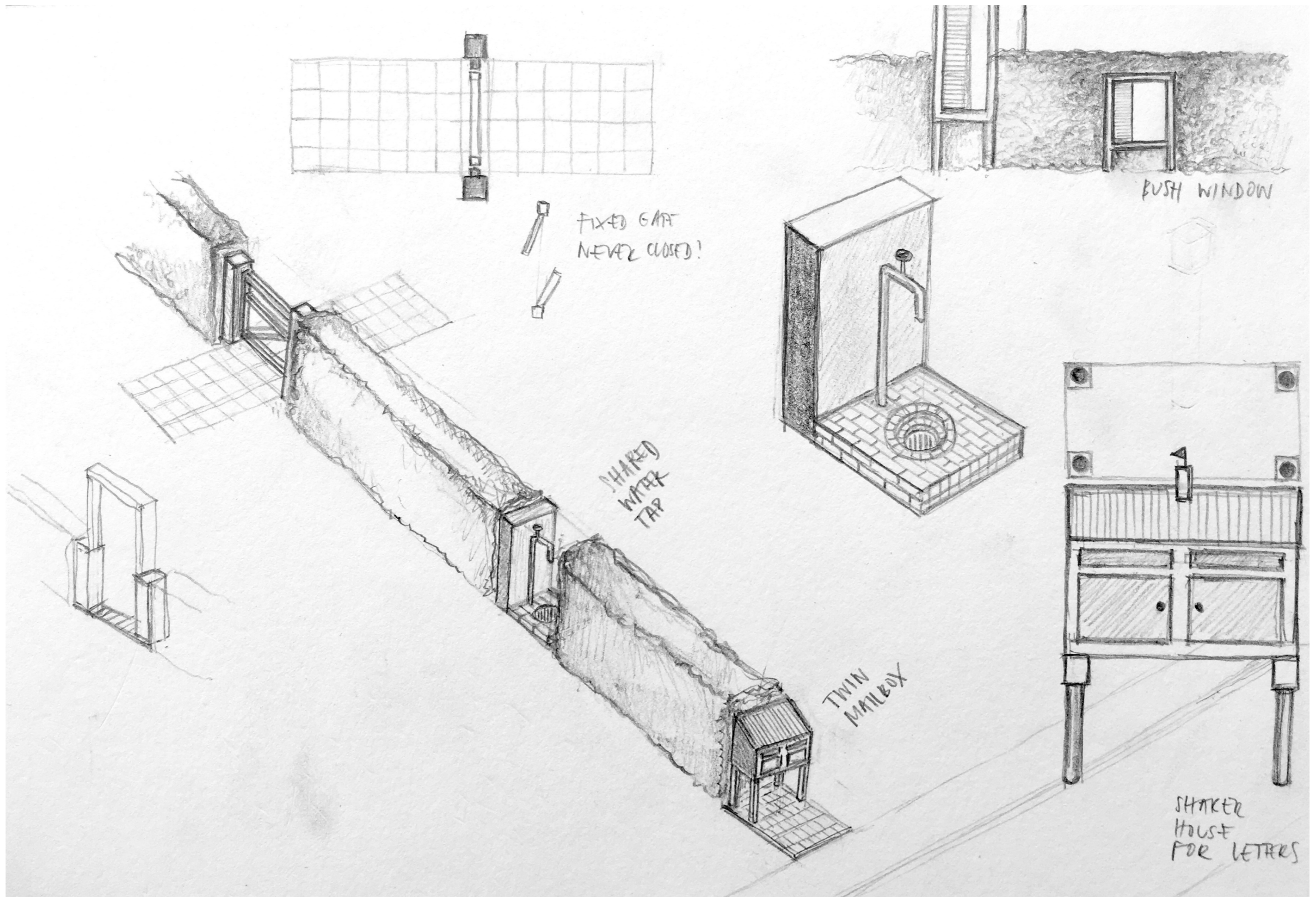





# Movement 2

## CH in BE



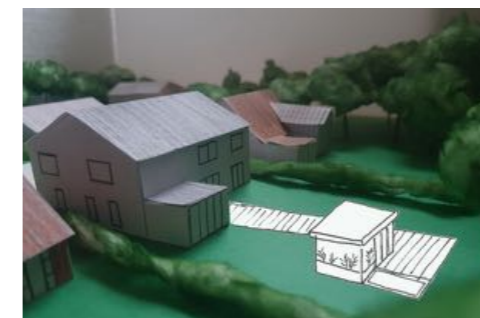



The Sky-View-Shower

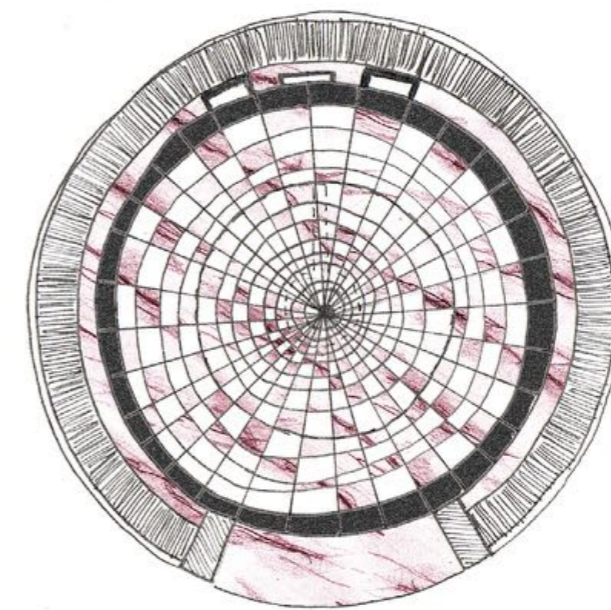
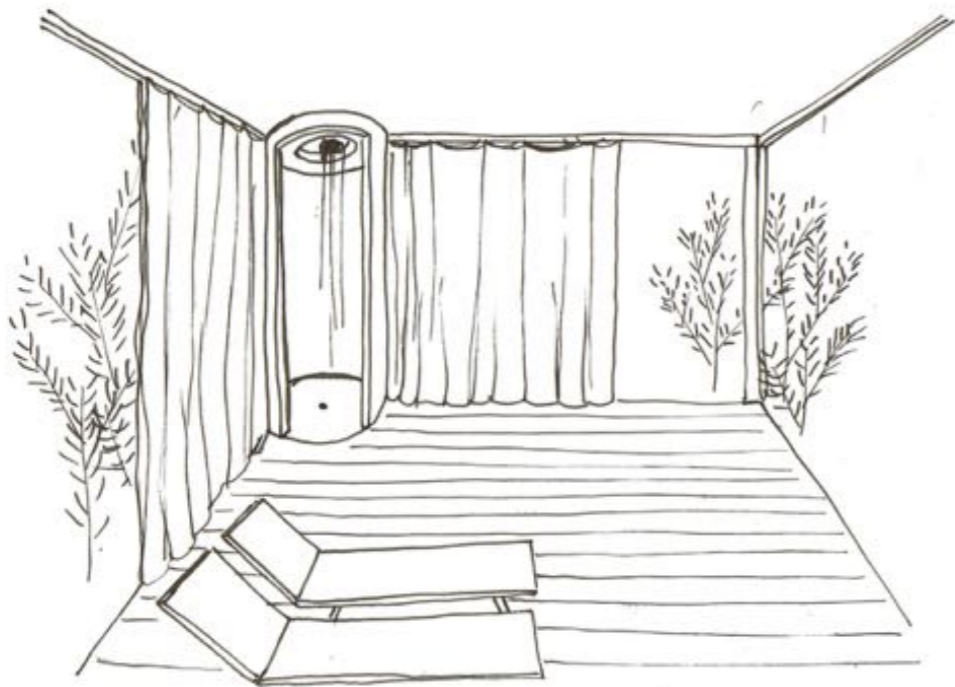
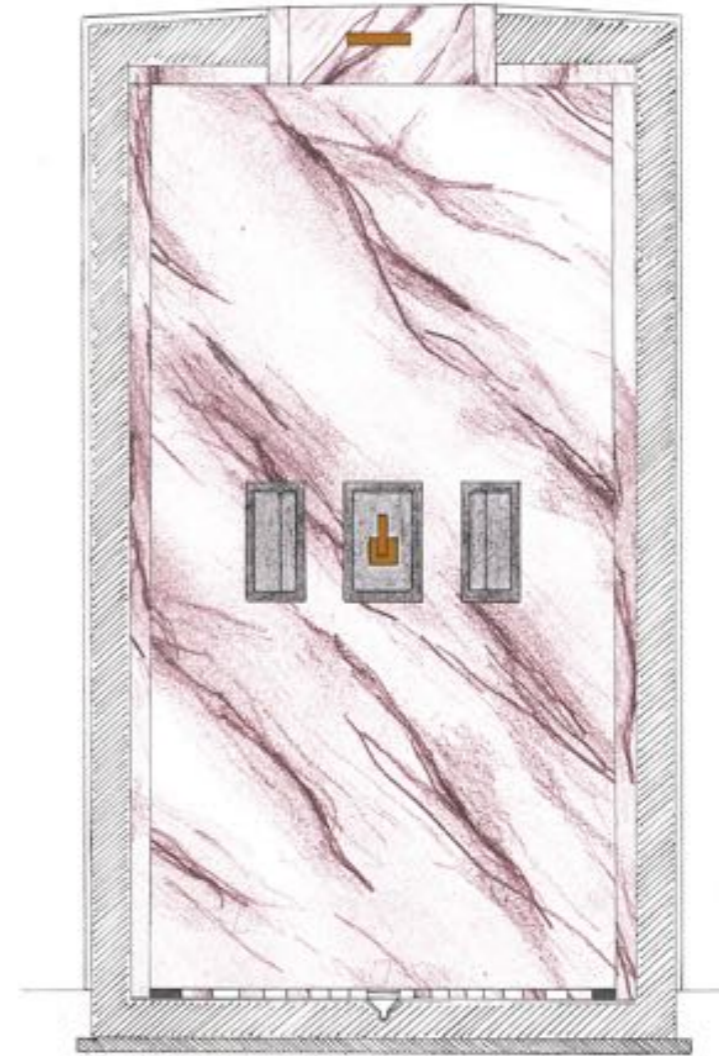

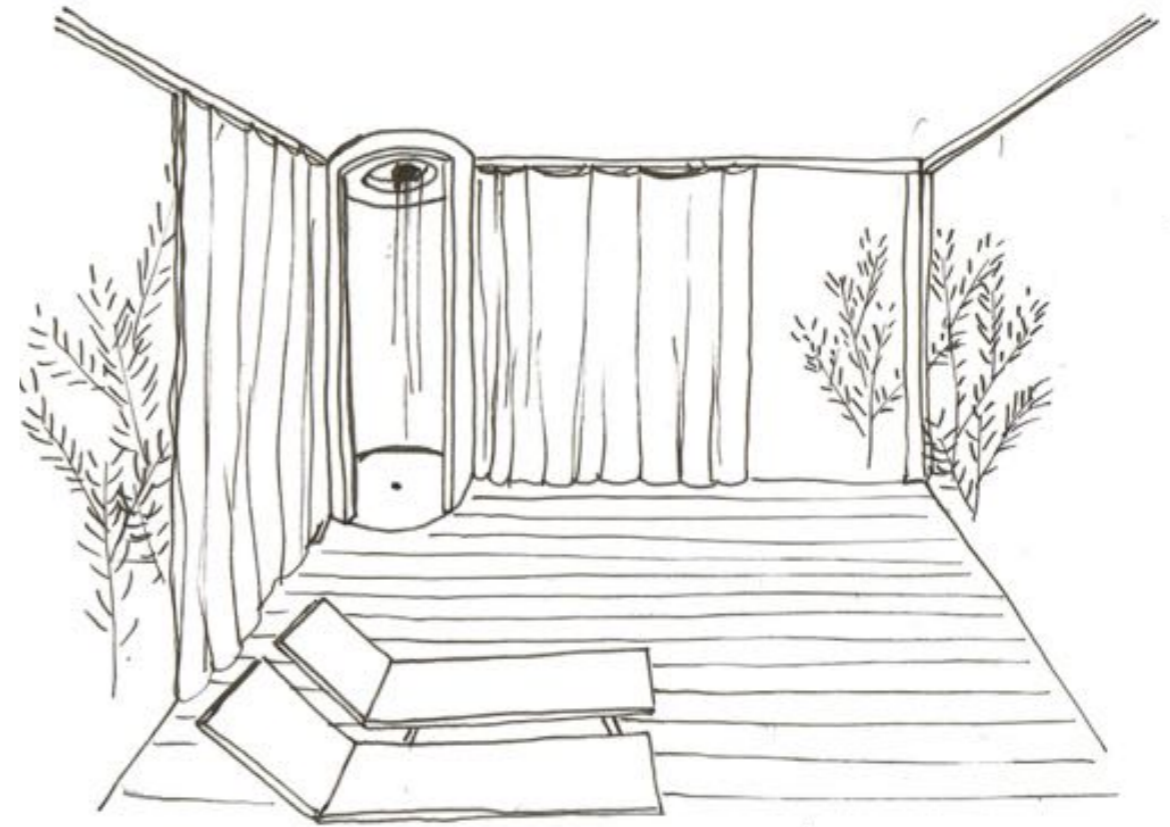
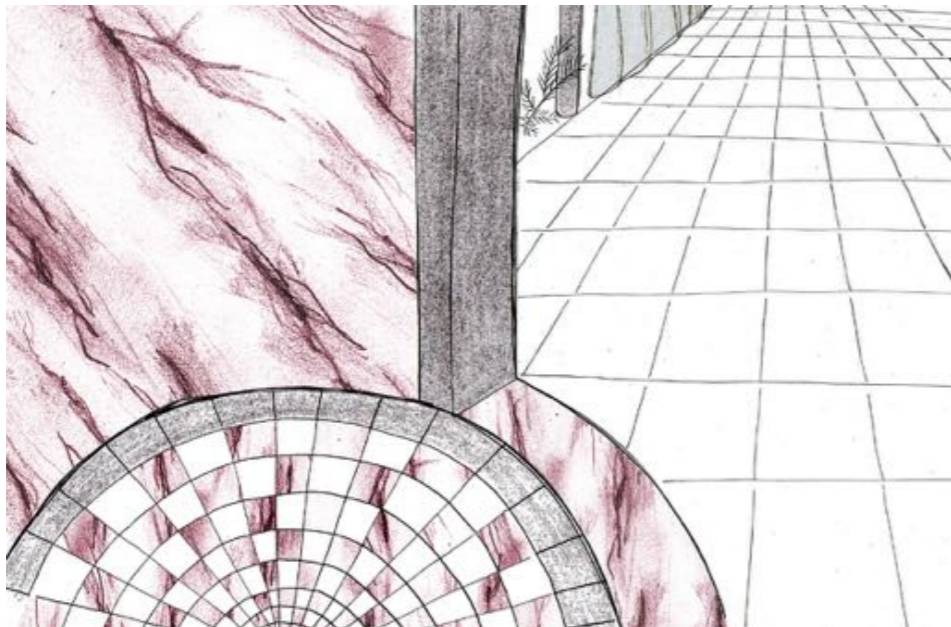
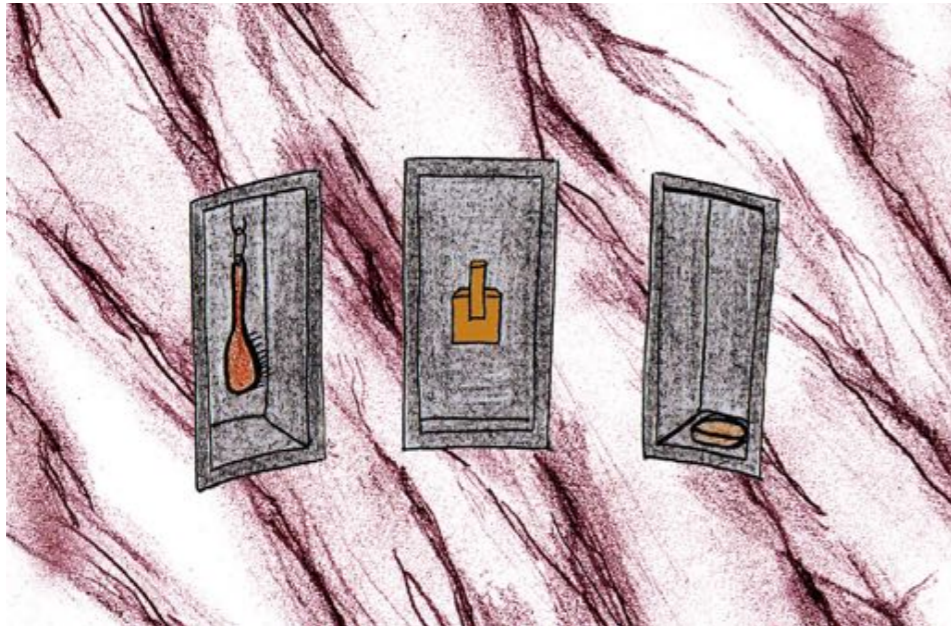





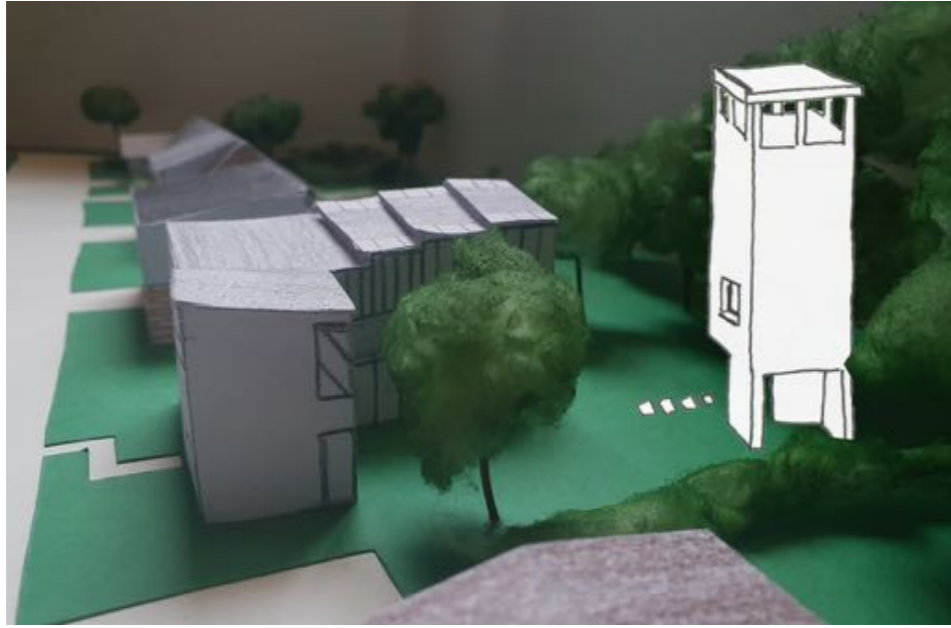

The Sauna Tower

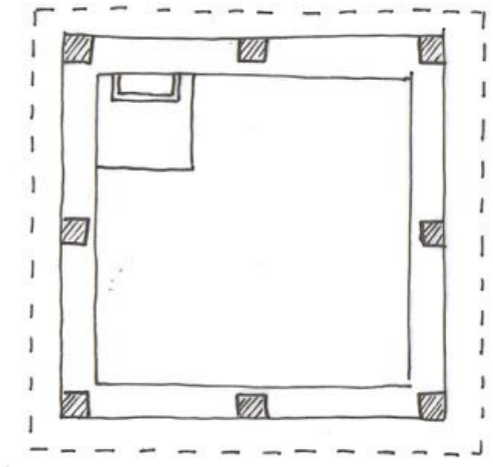
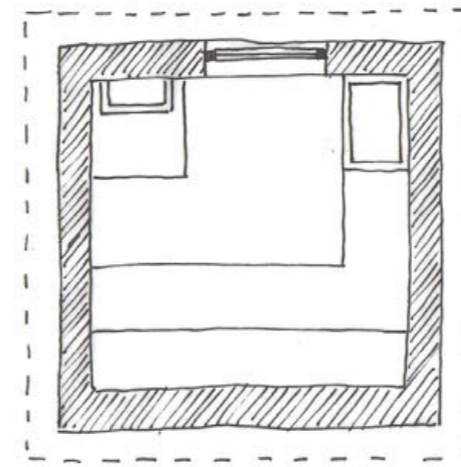
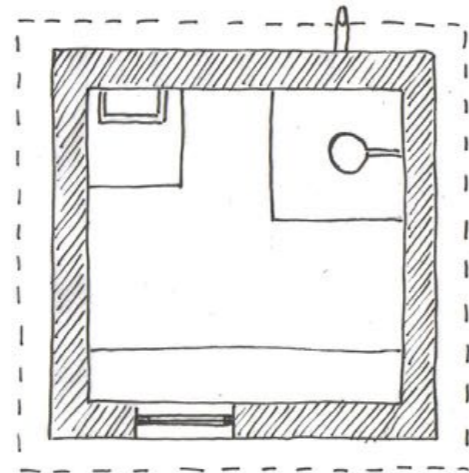
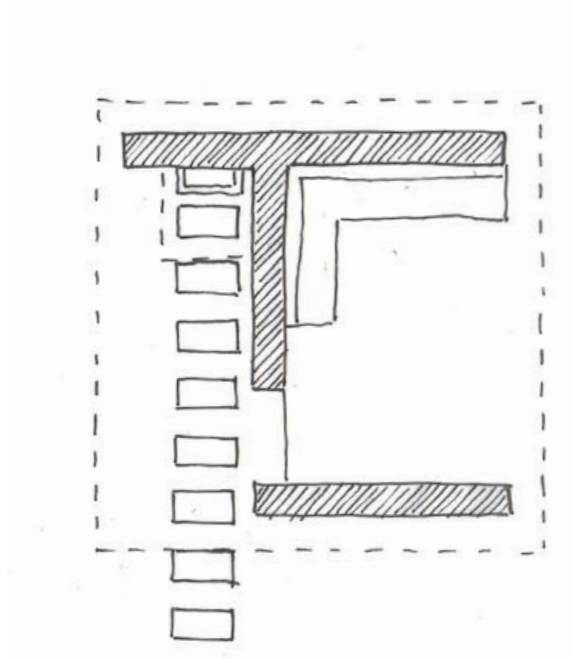
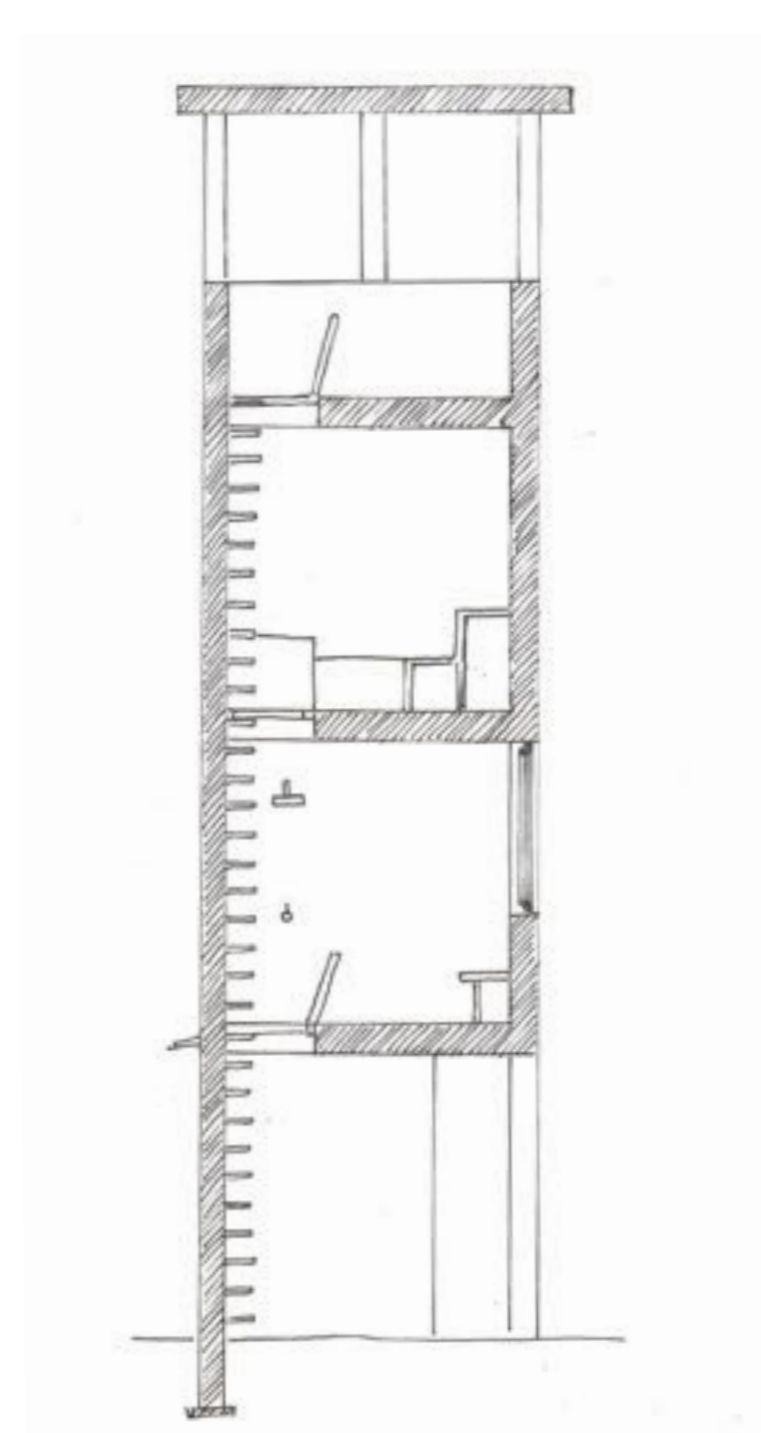

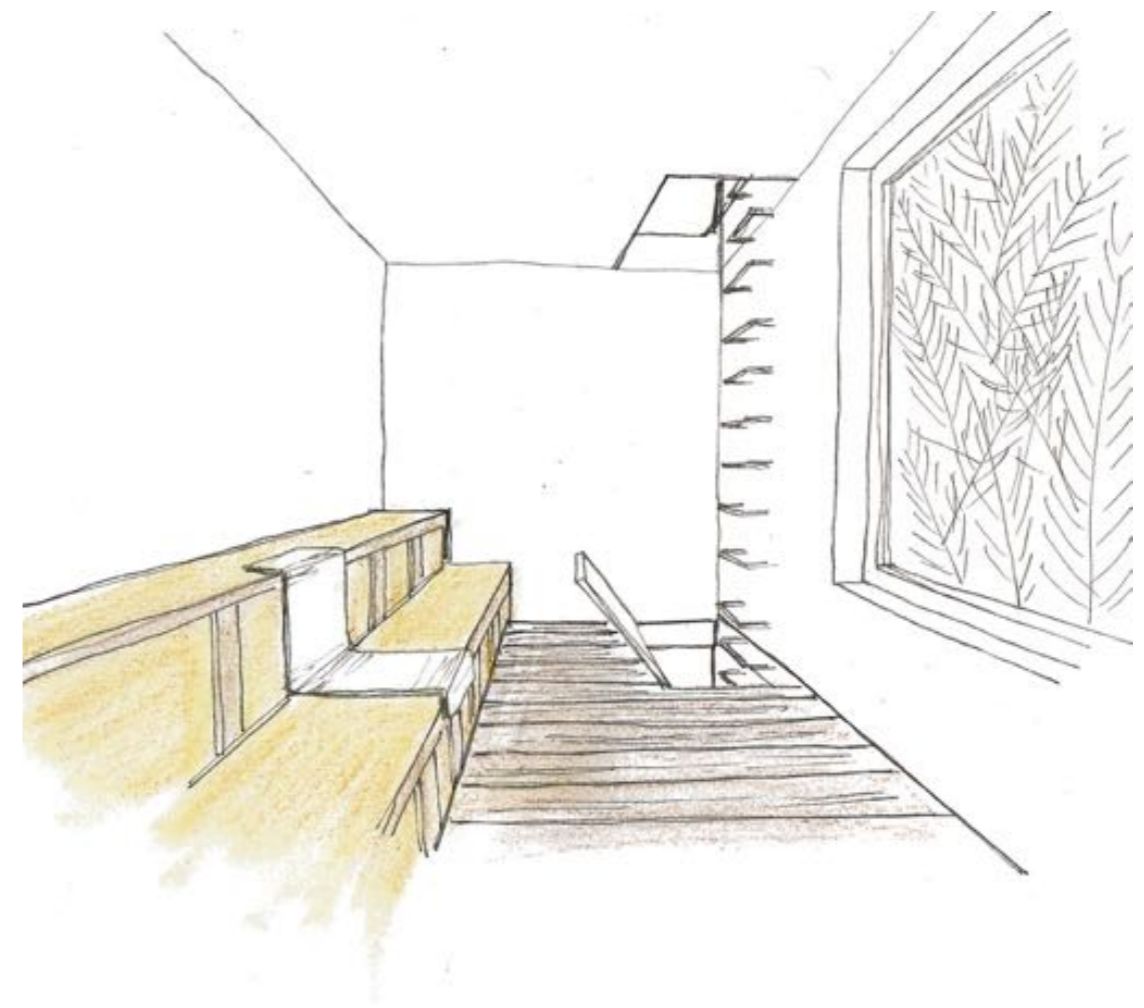
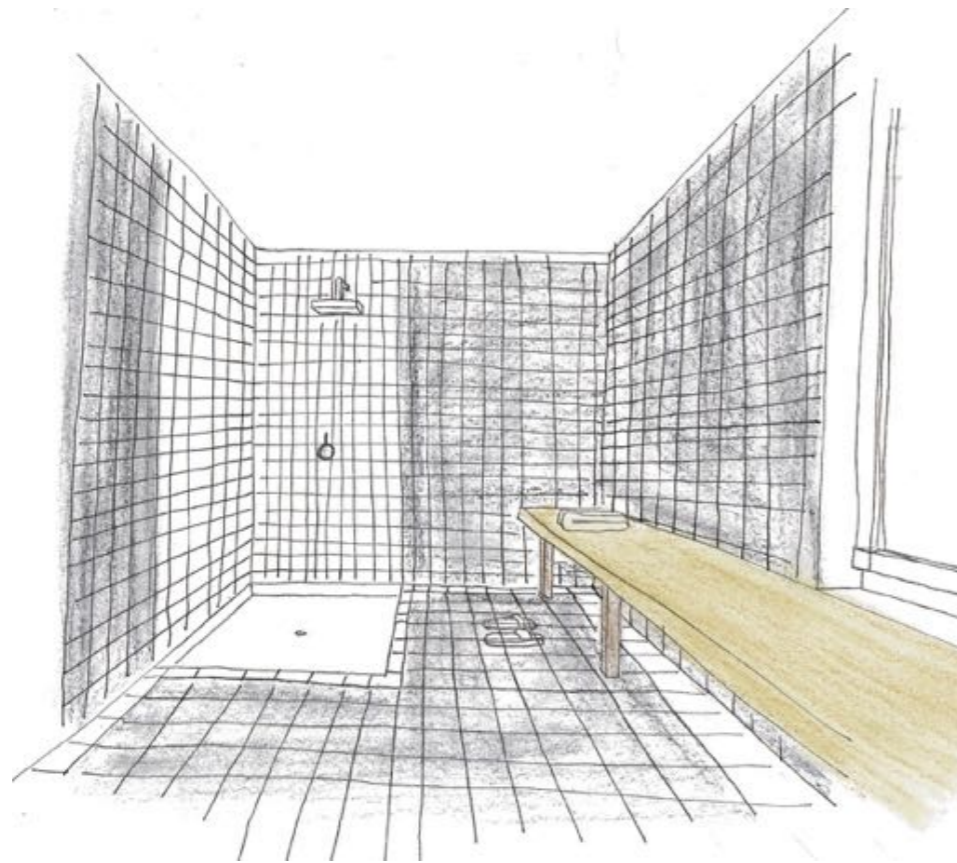



The Hammock Lamp

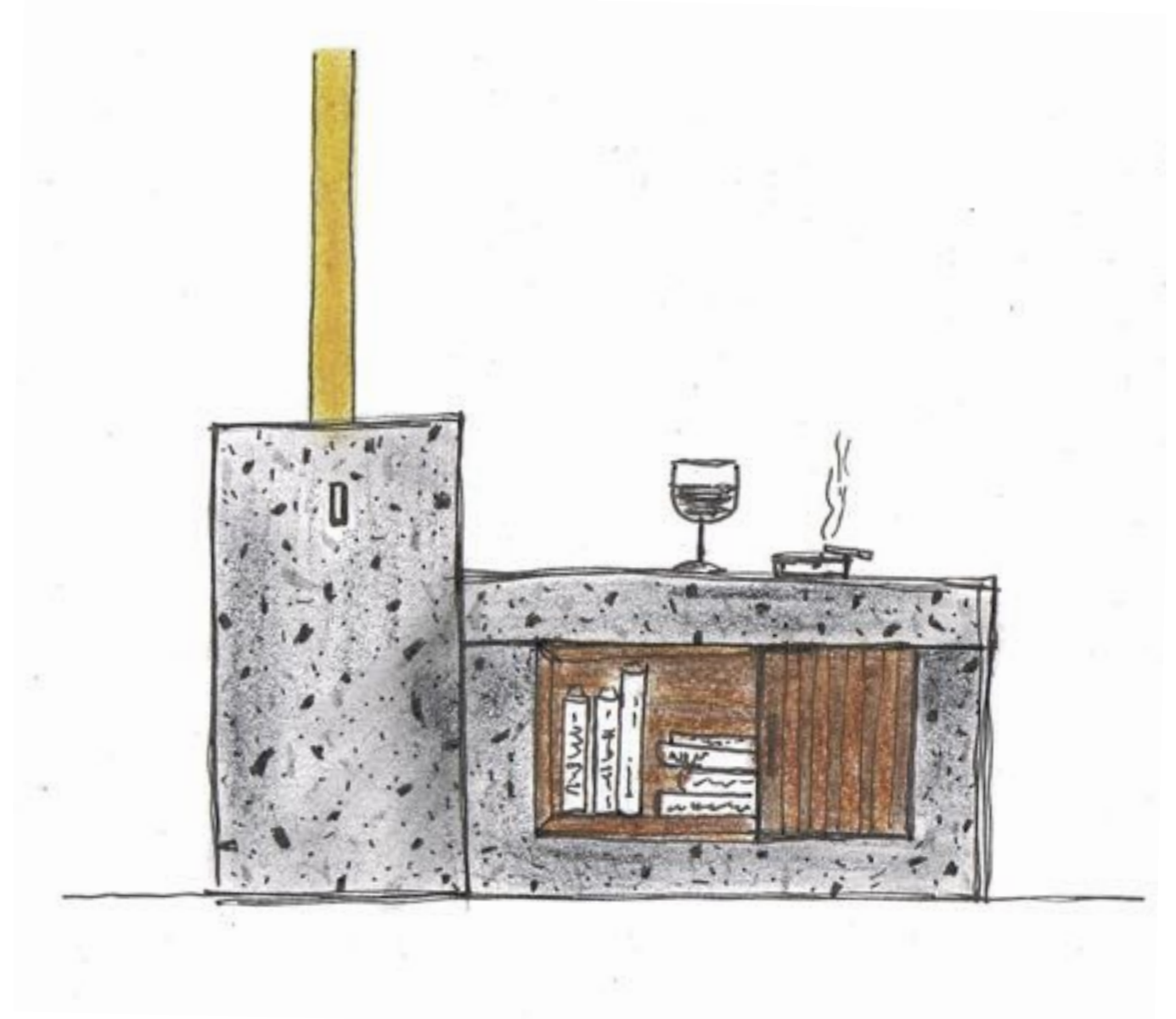
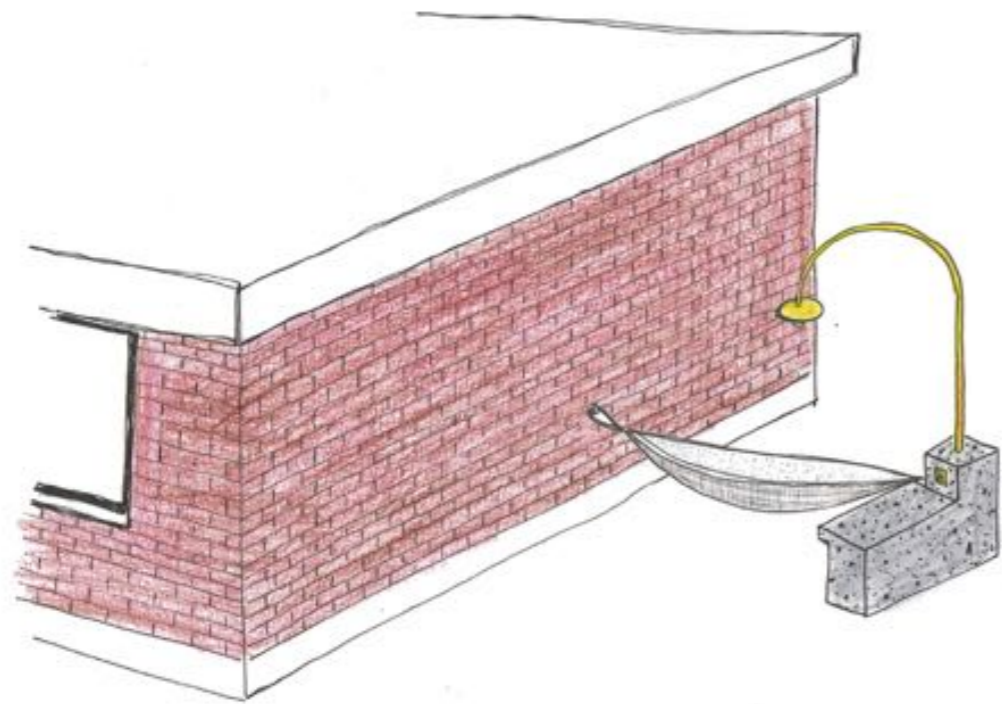

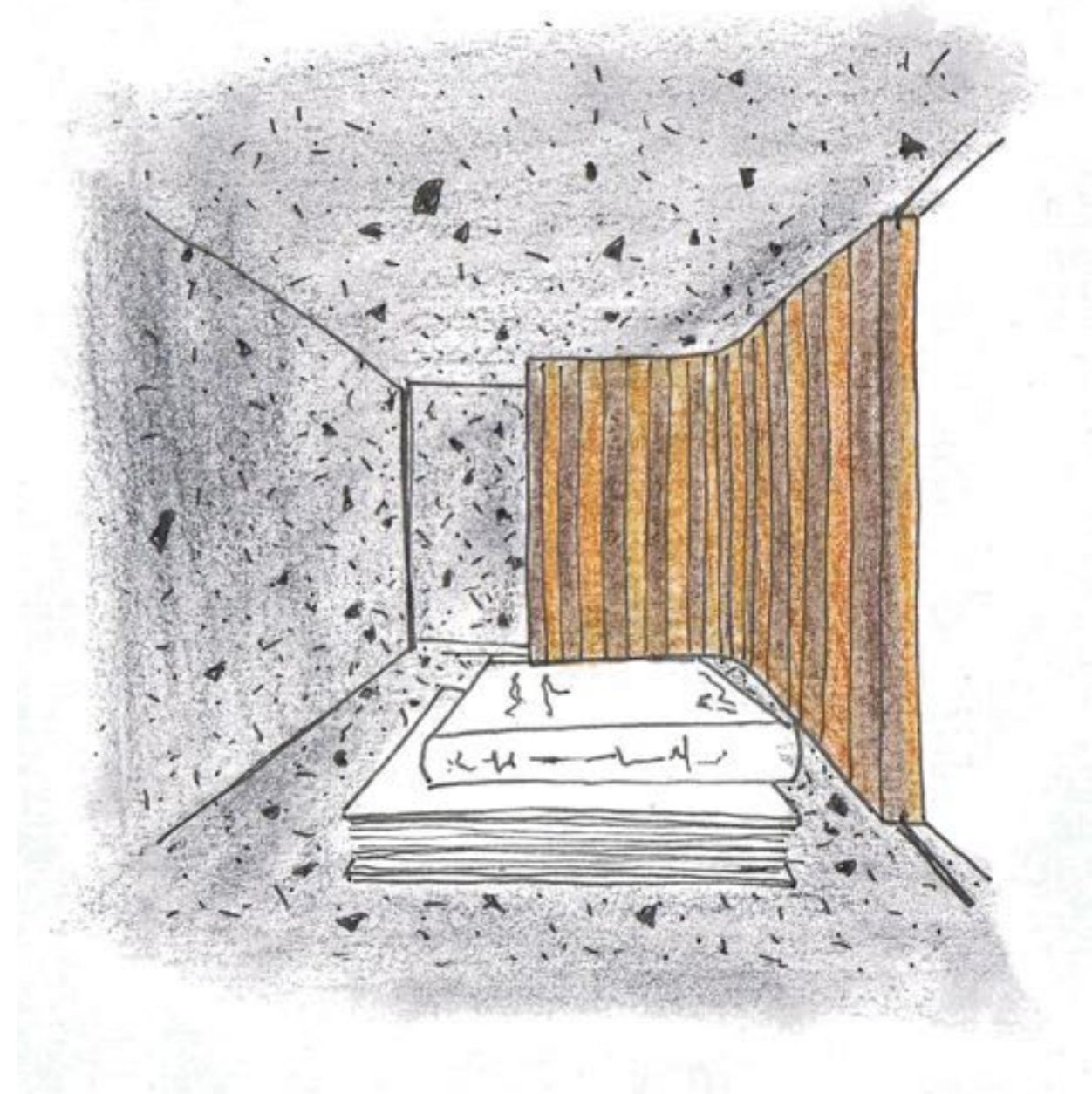
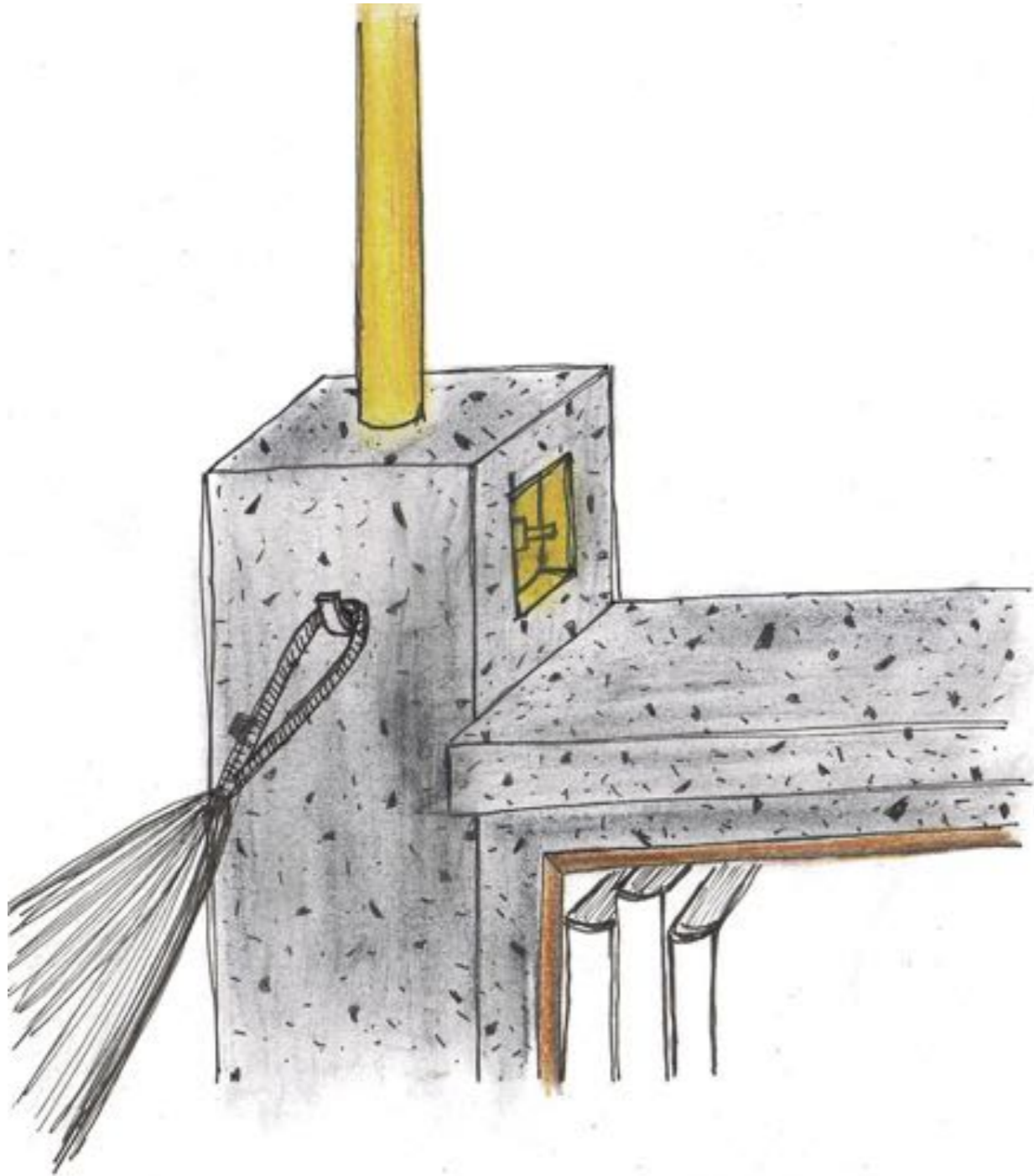

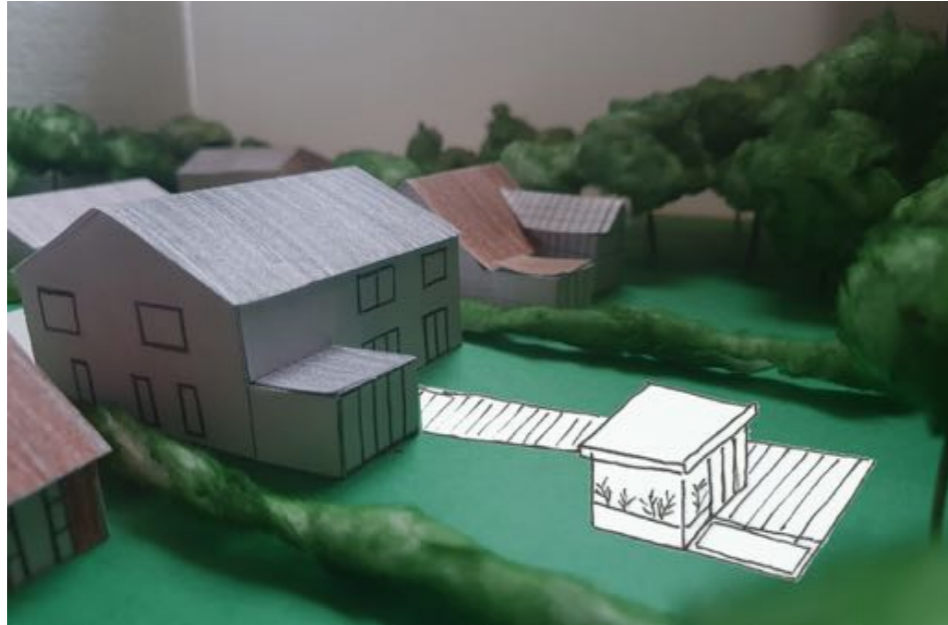

The Guest Suite

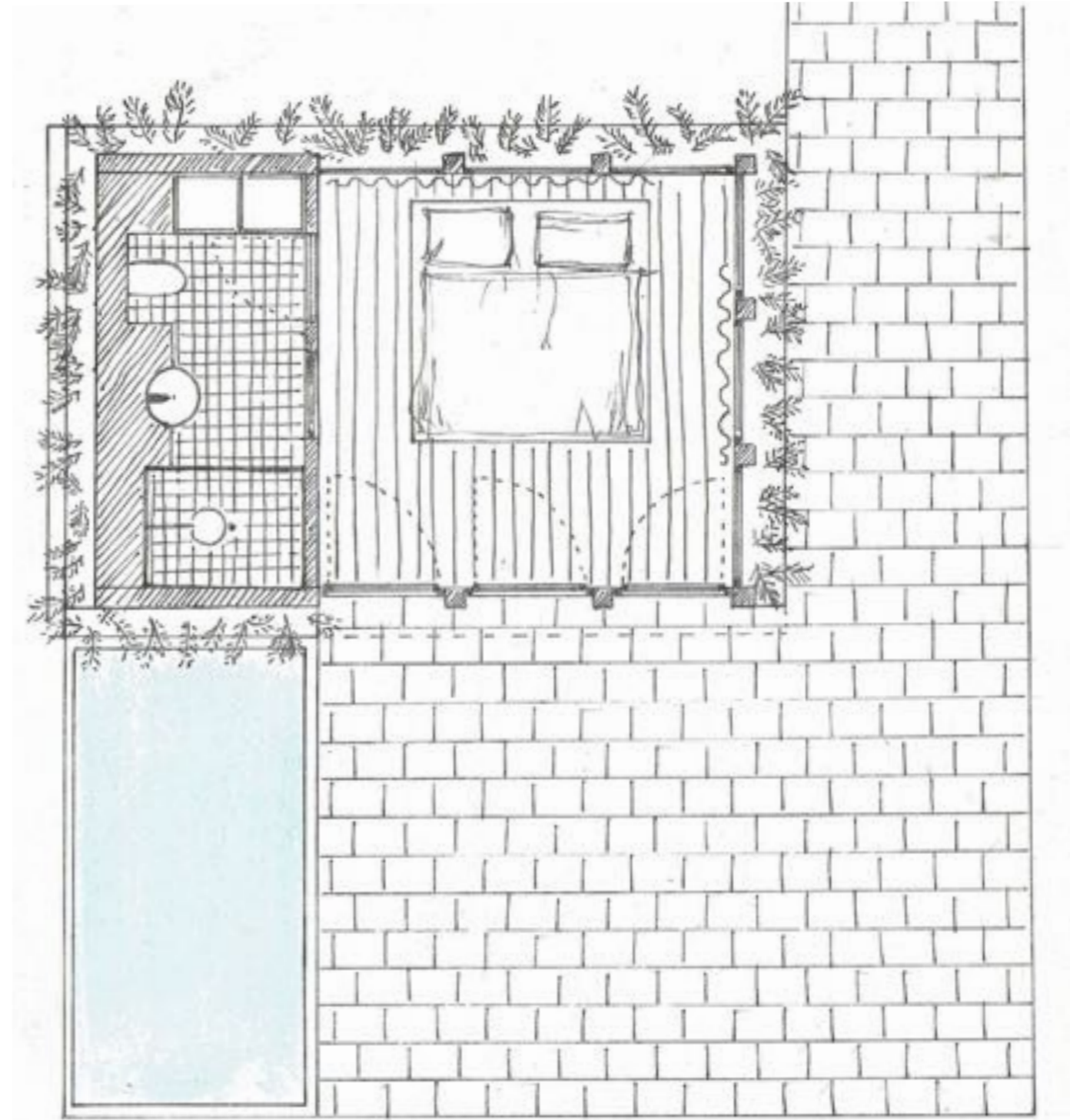

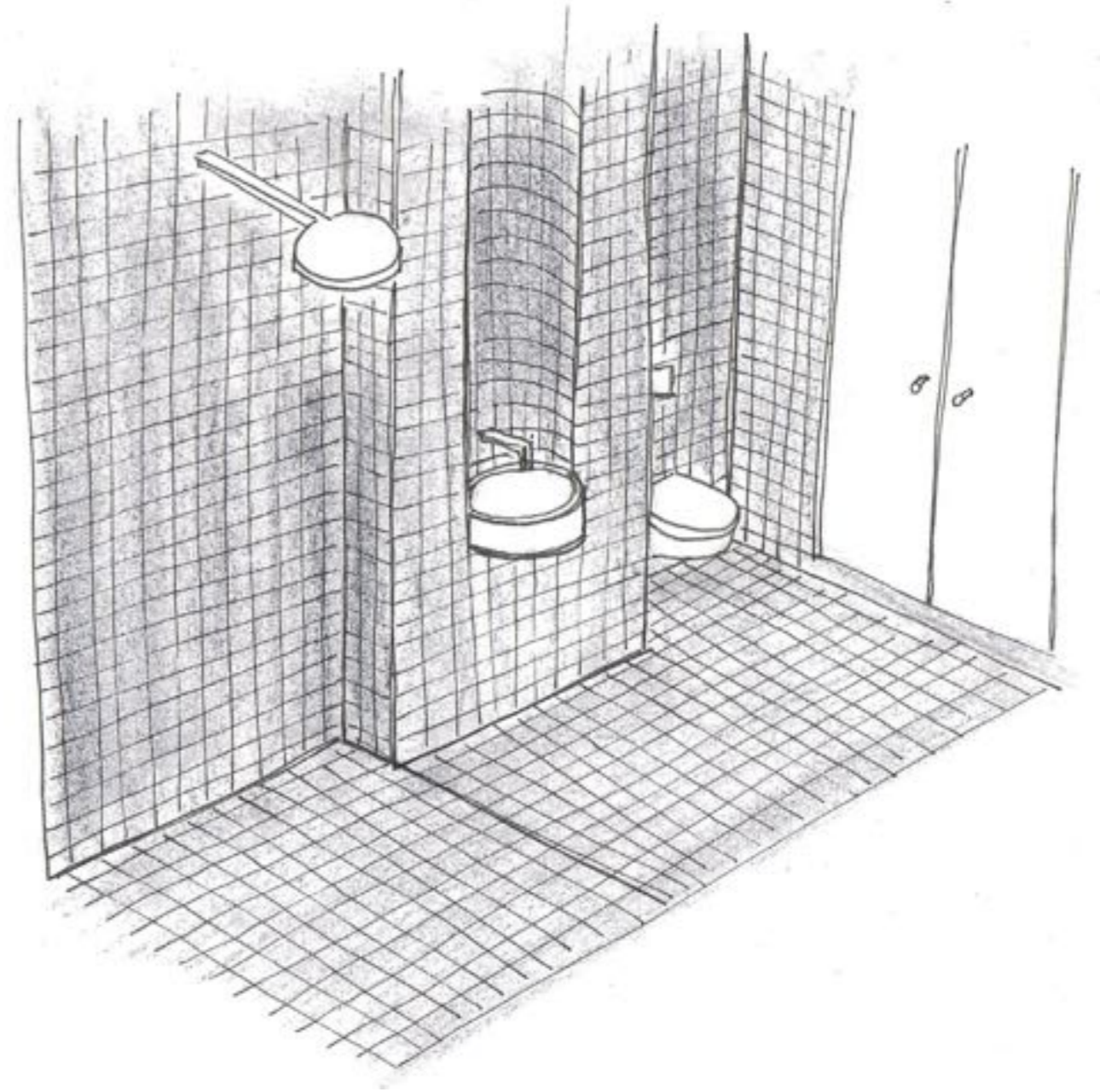

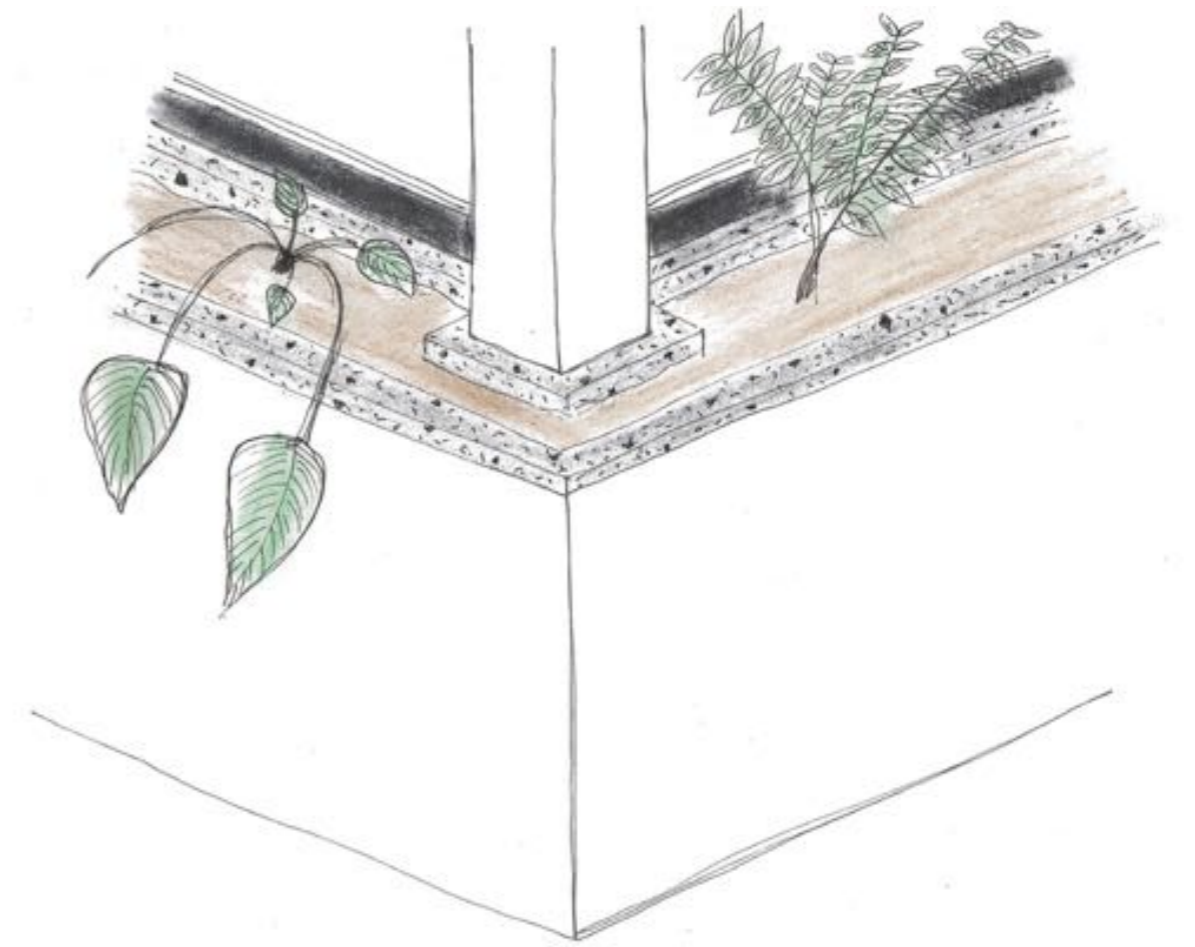





The Sunny Day Kitchen

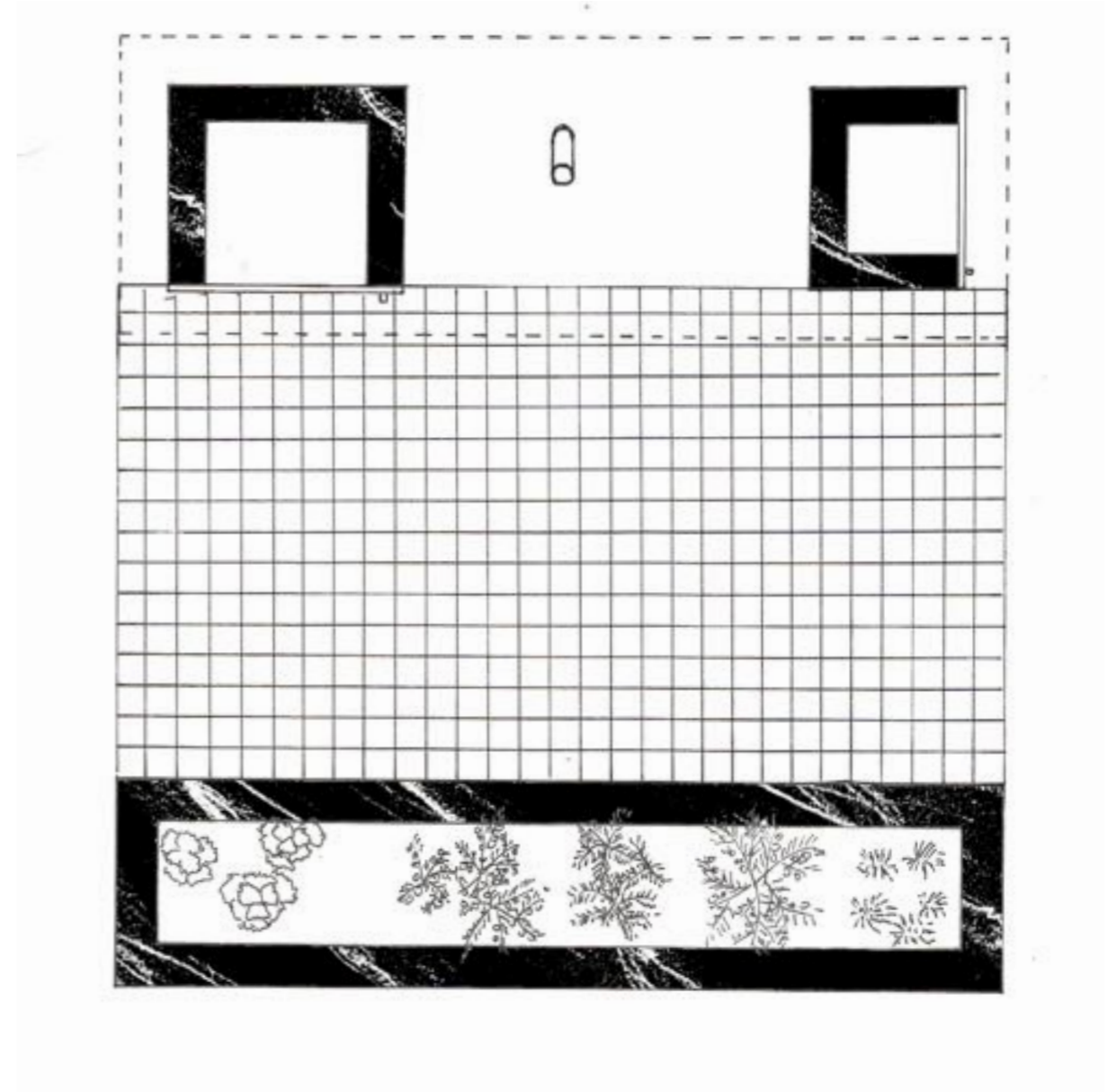
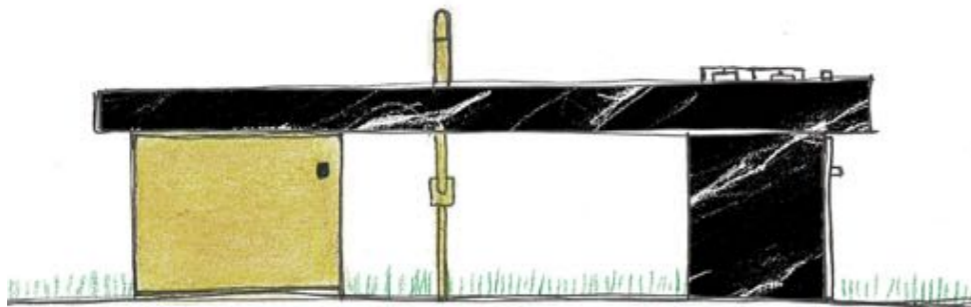

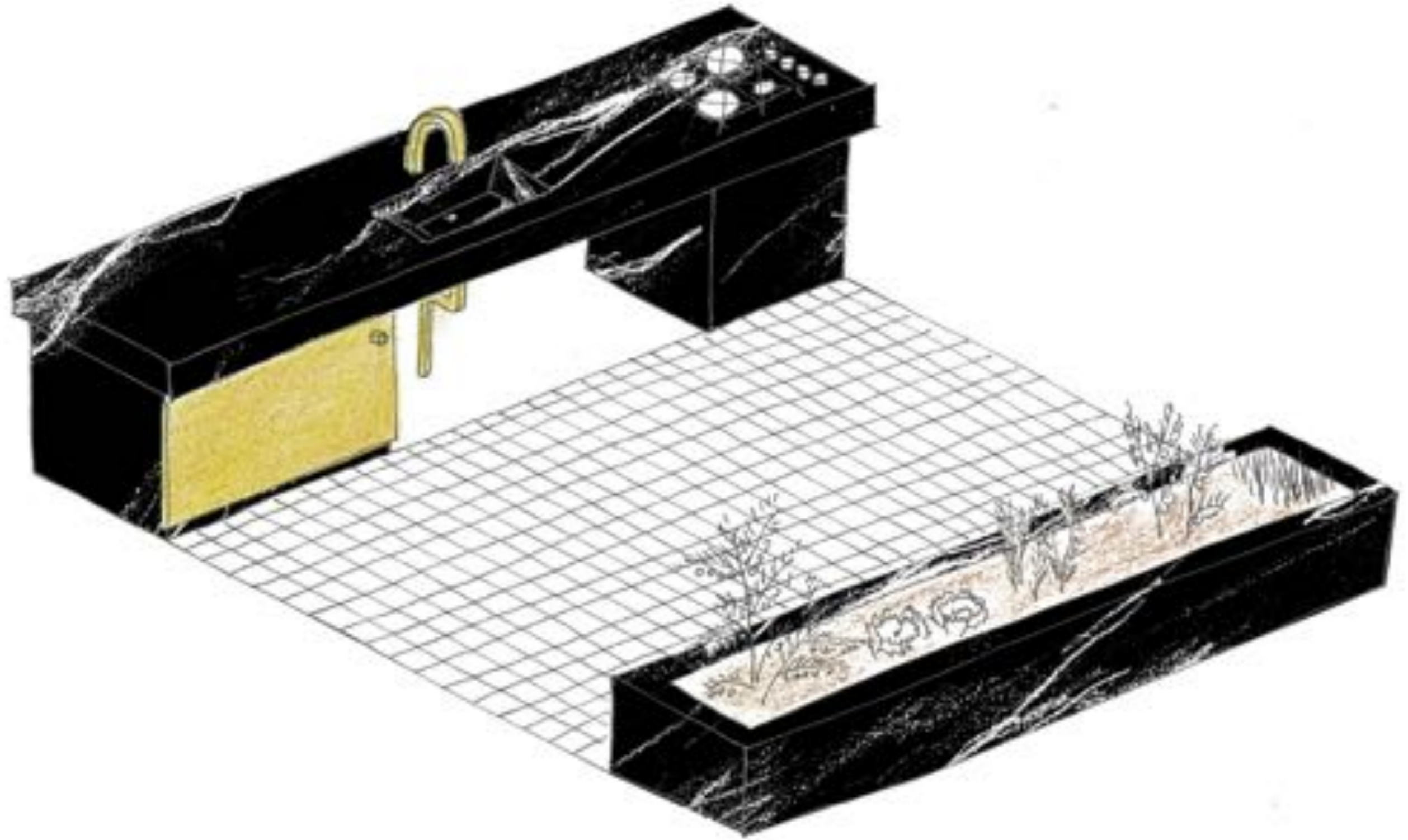

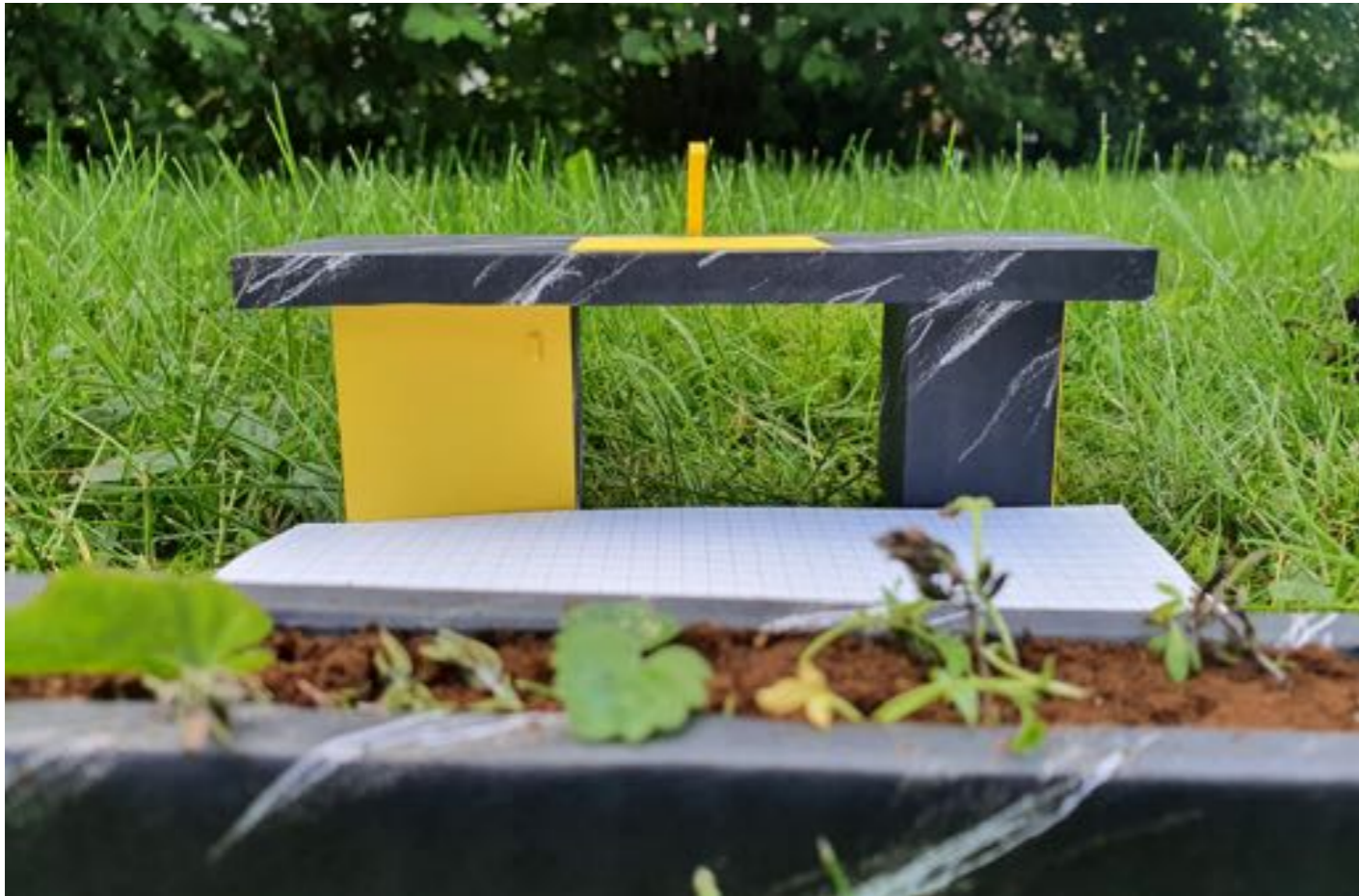

# Dialogue



# Movement 2

## US in CH



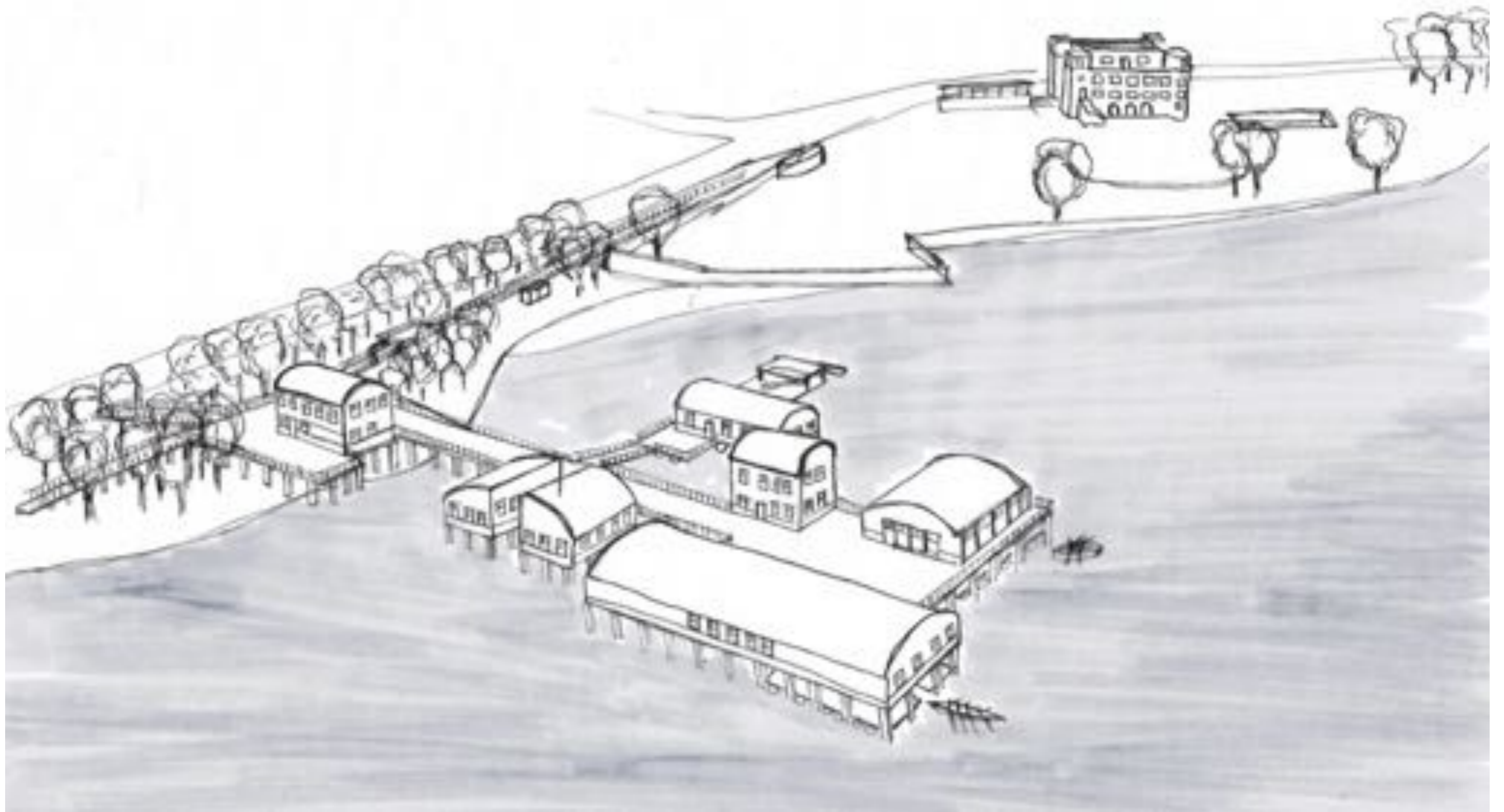

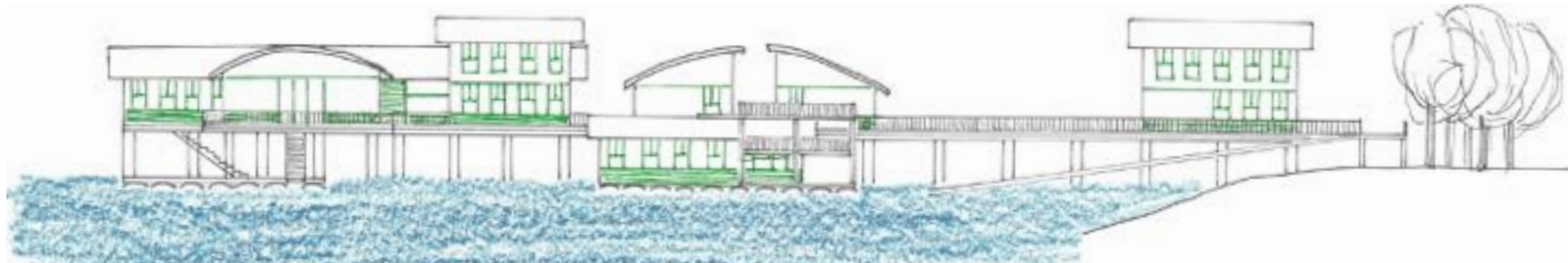
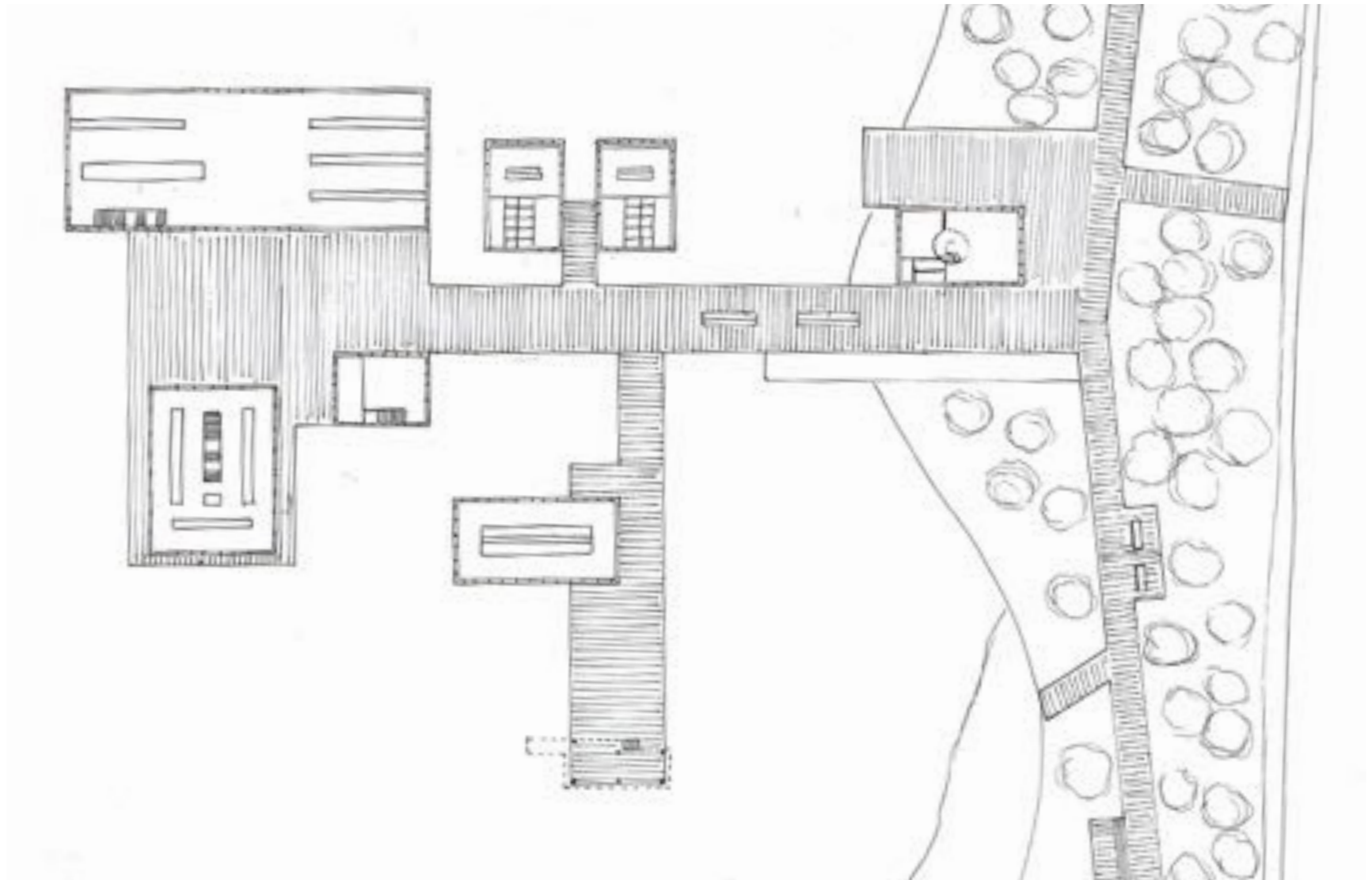

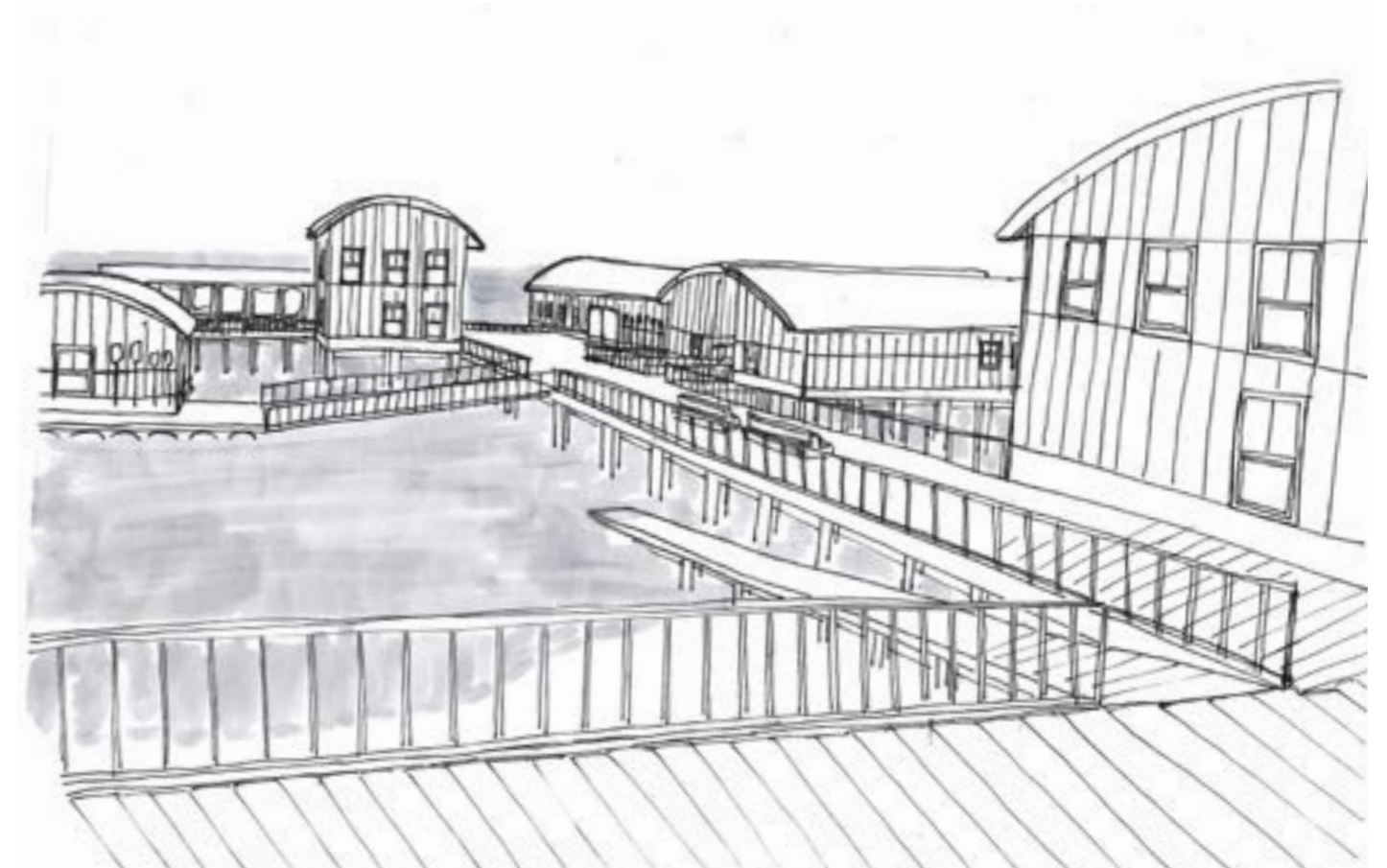





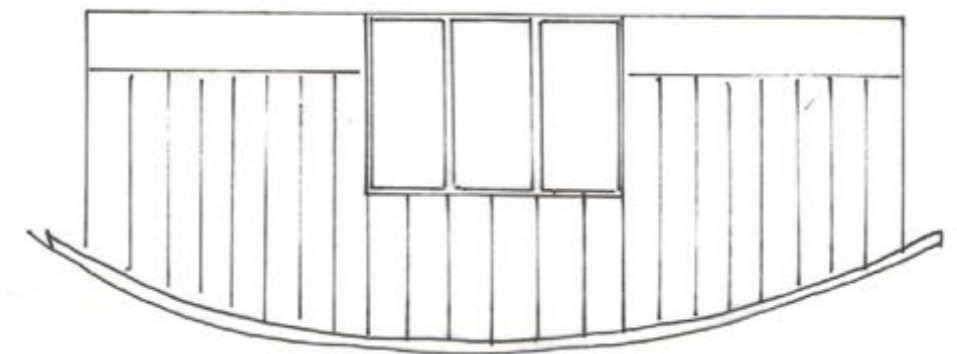
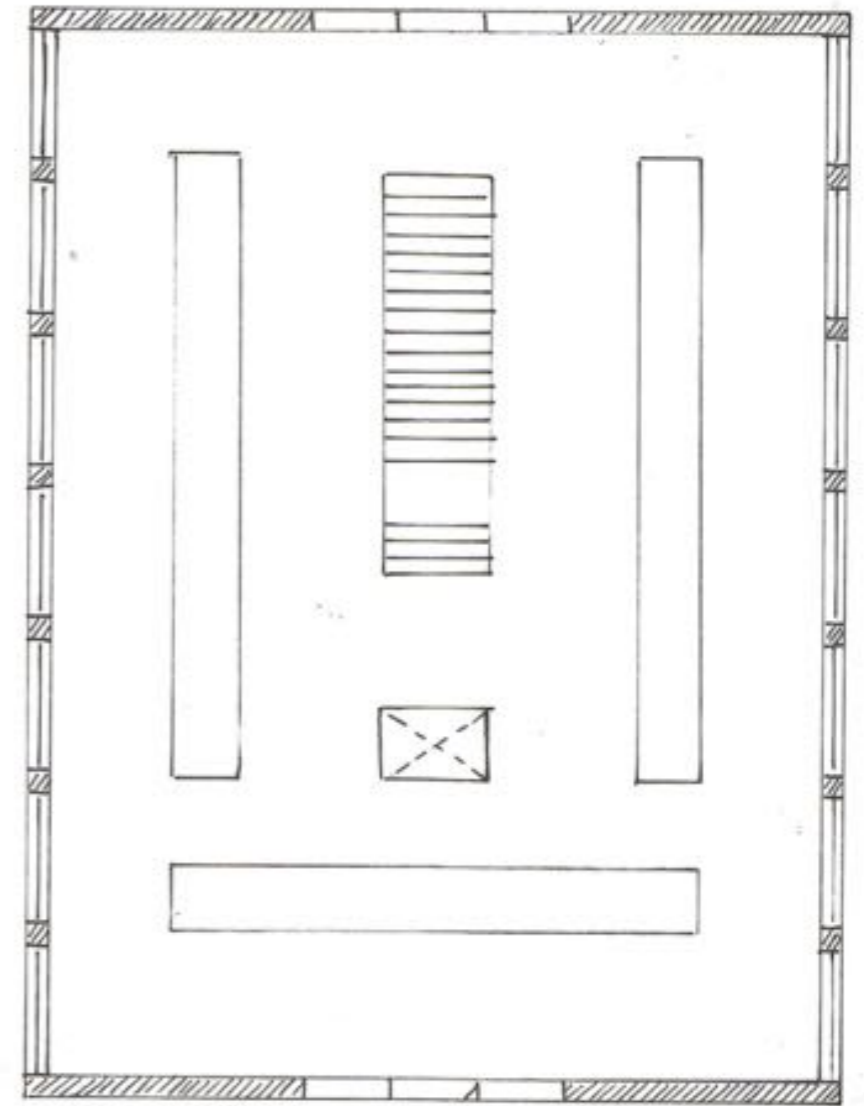
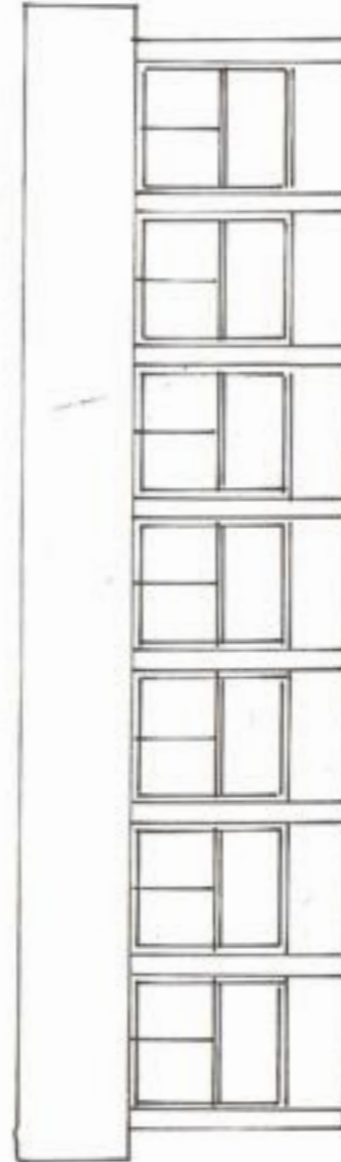
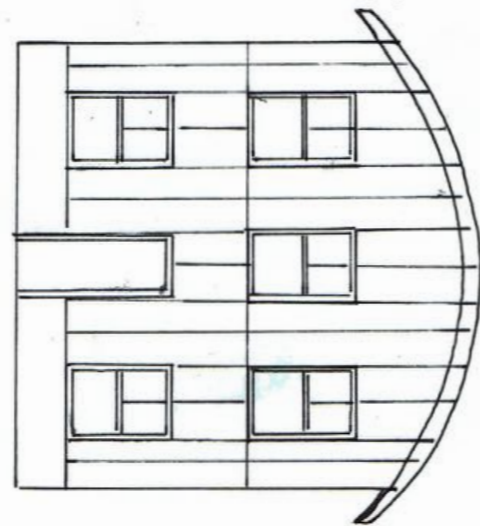
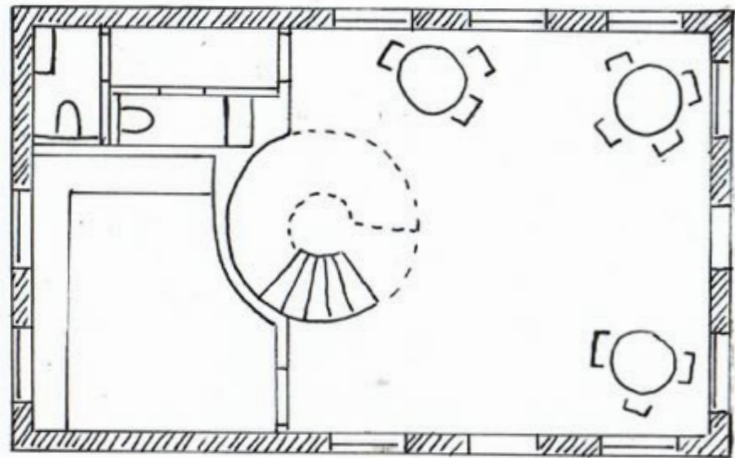
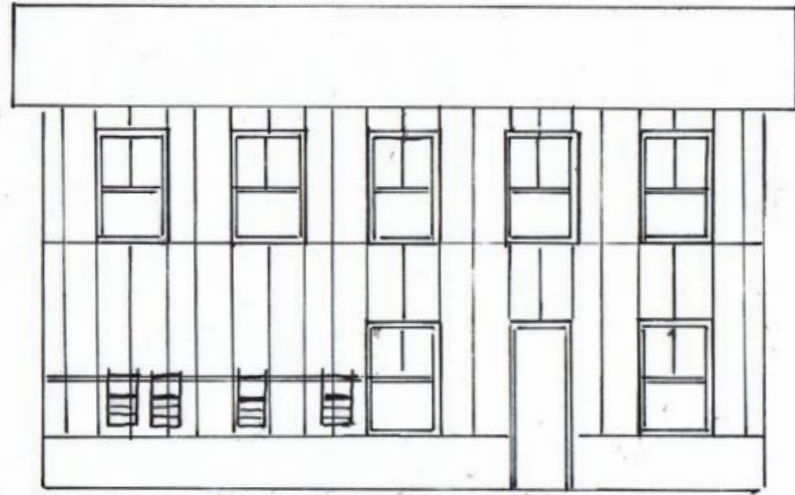

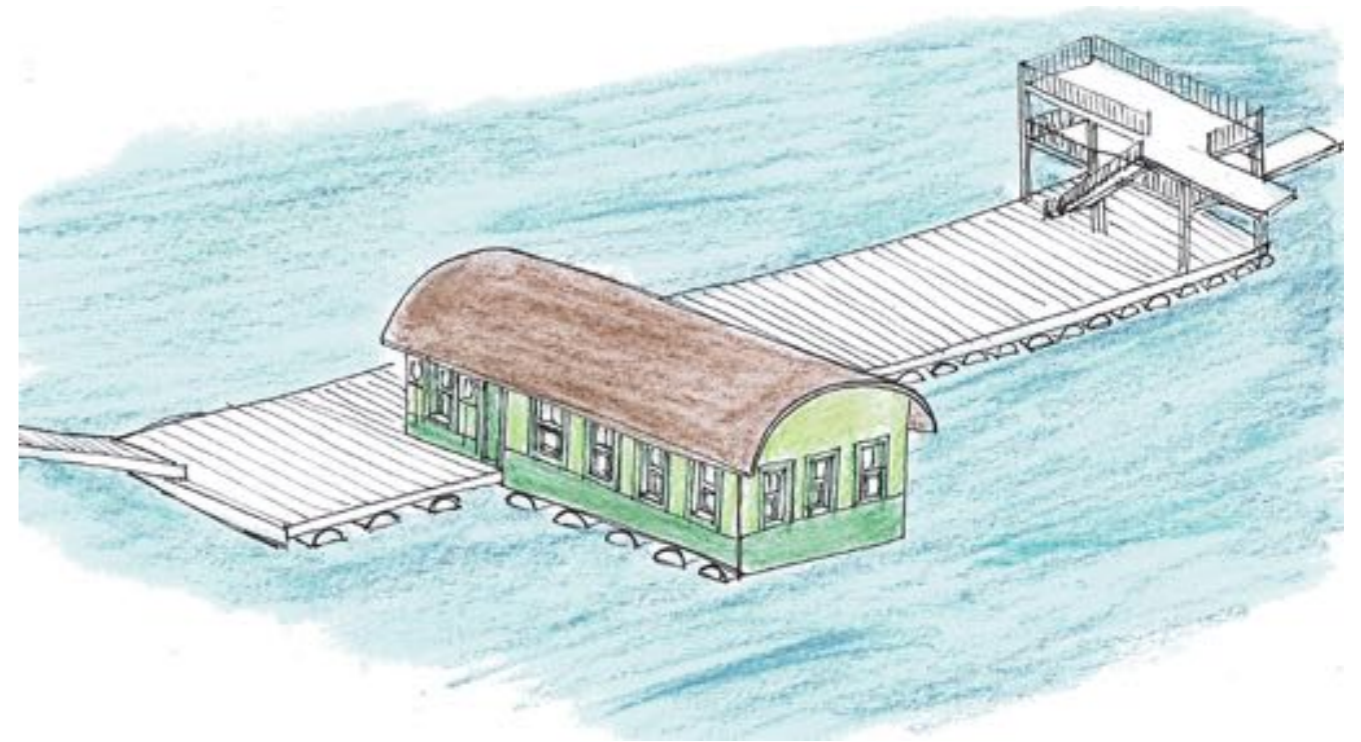
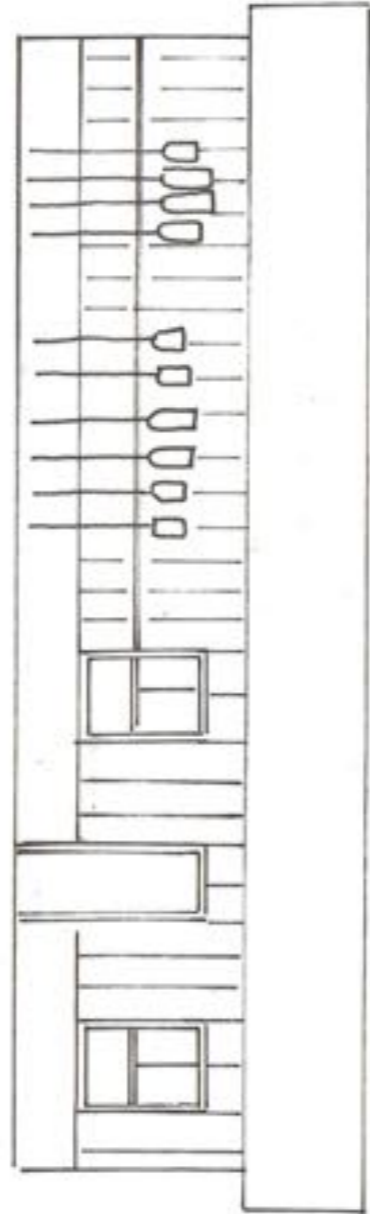
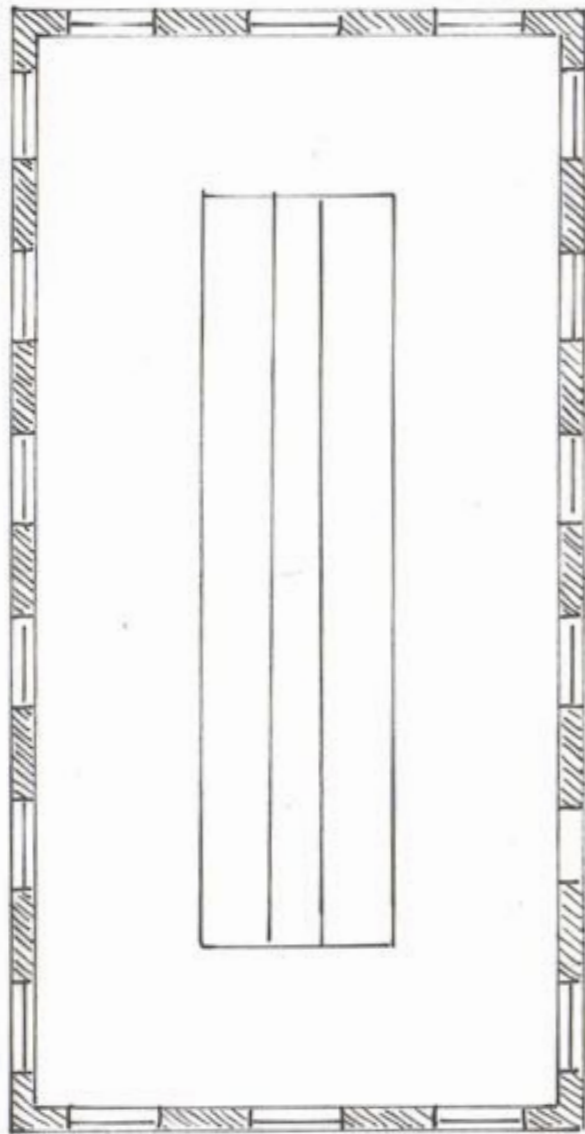
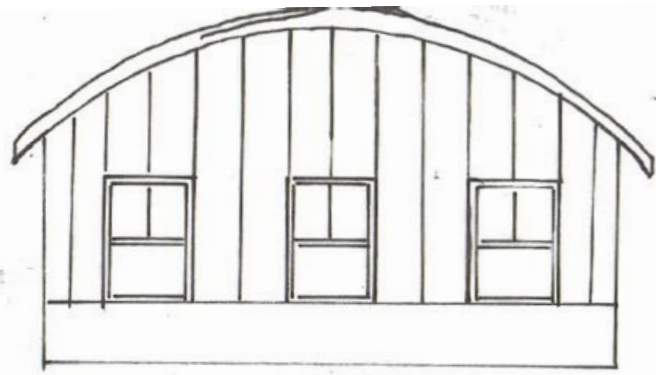

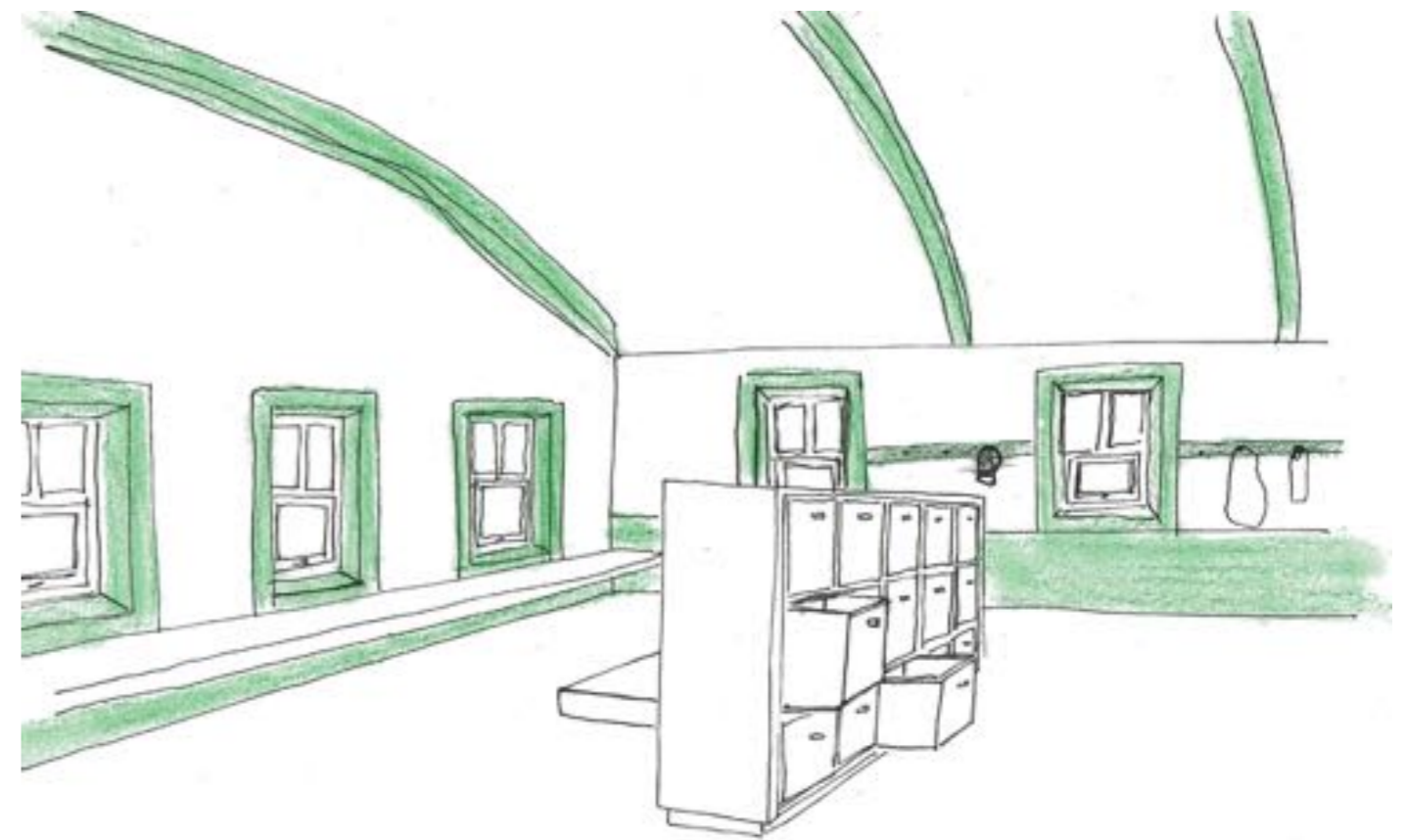
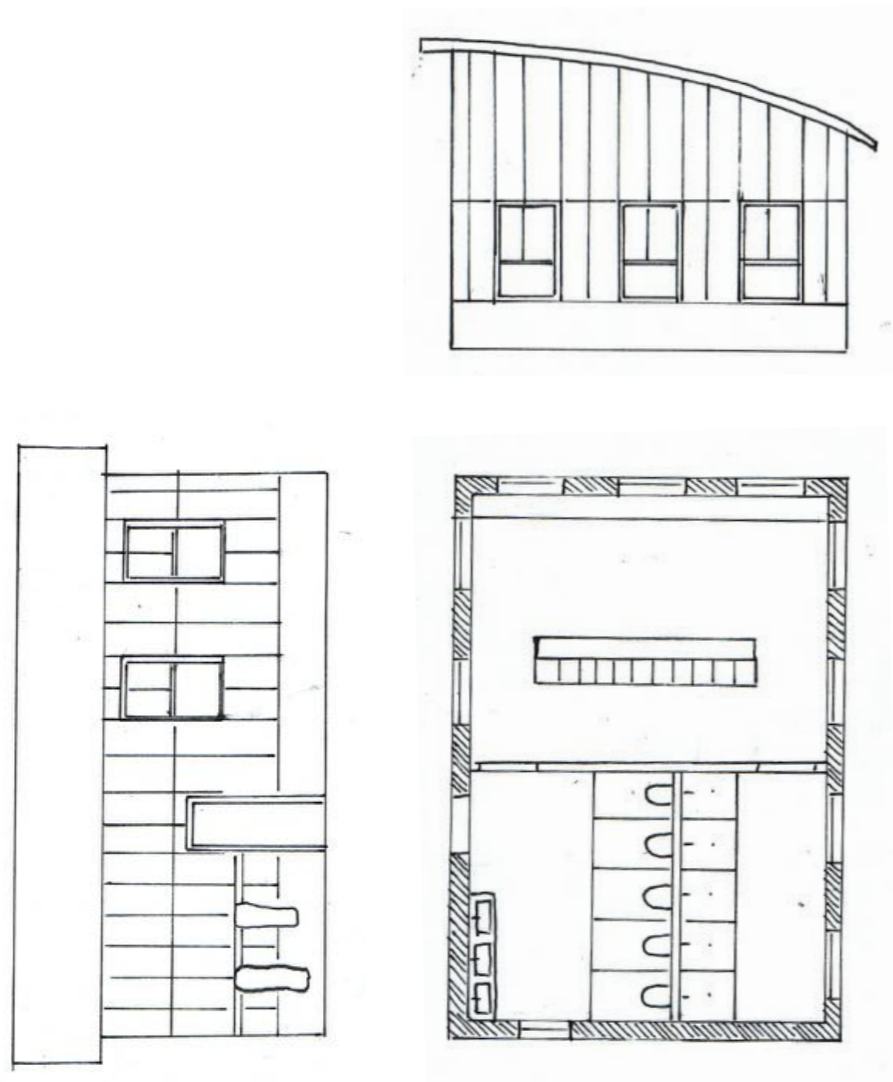

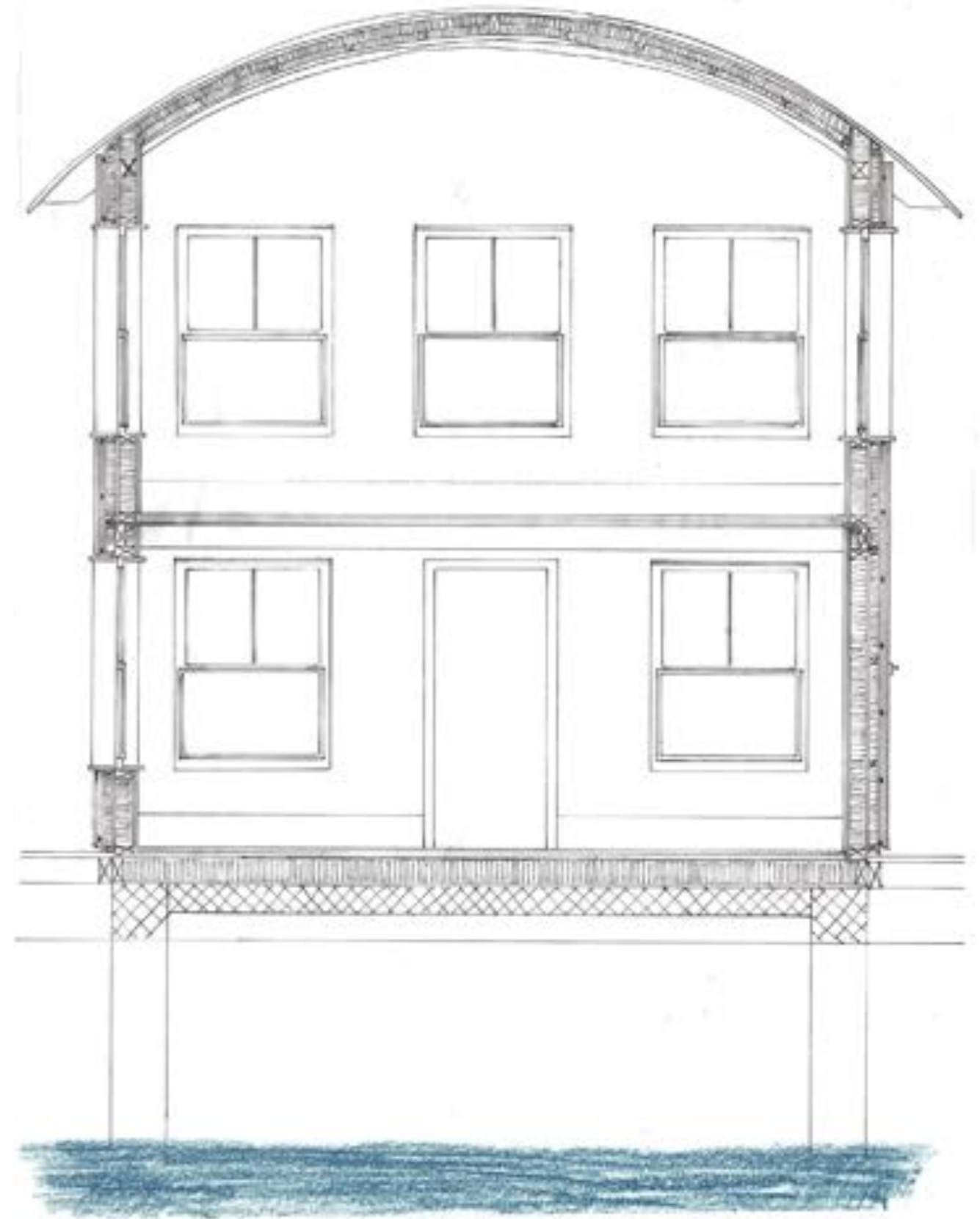
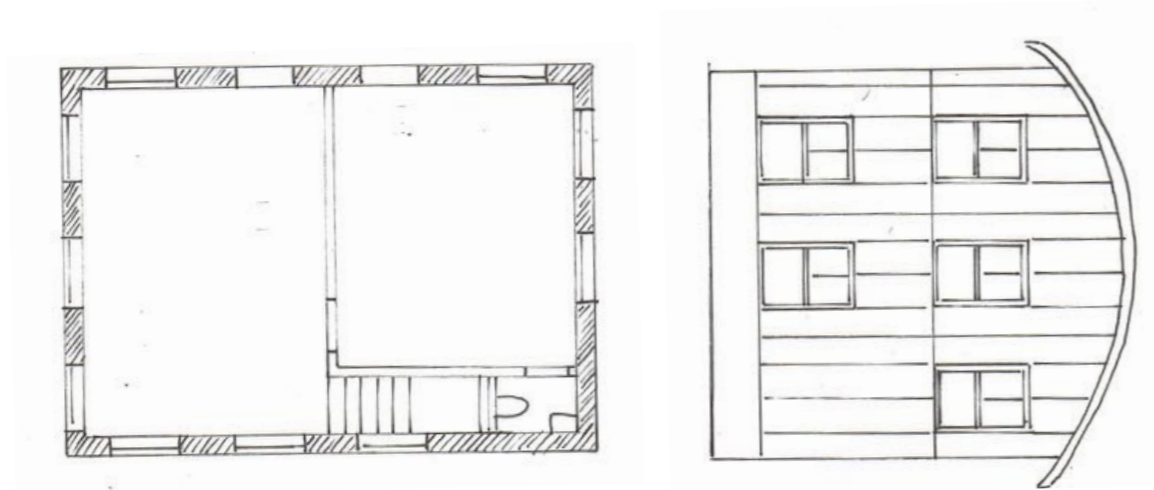

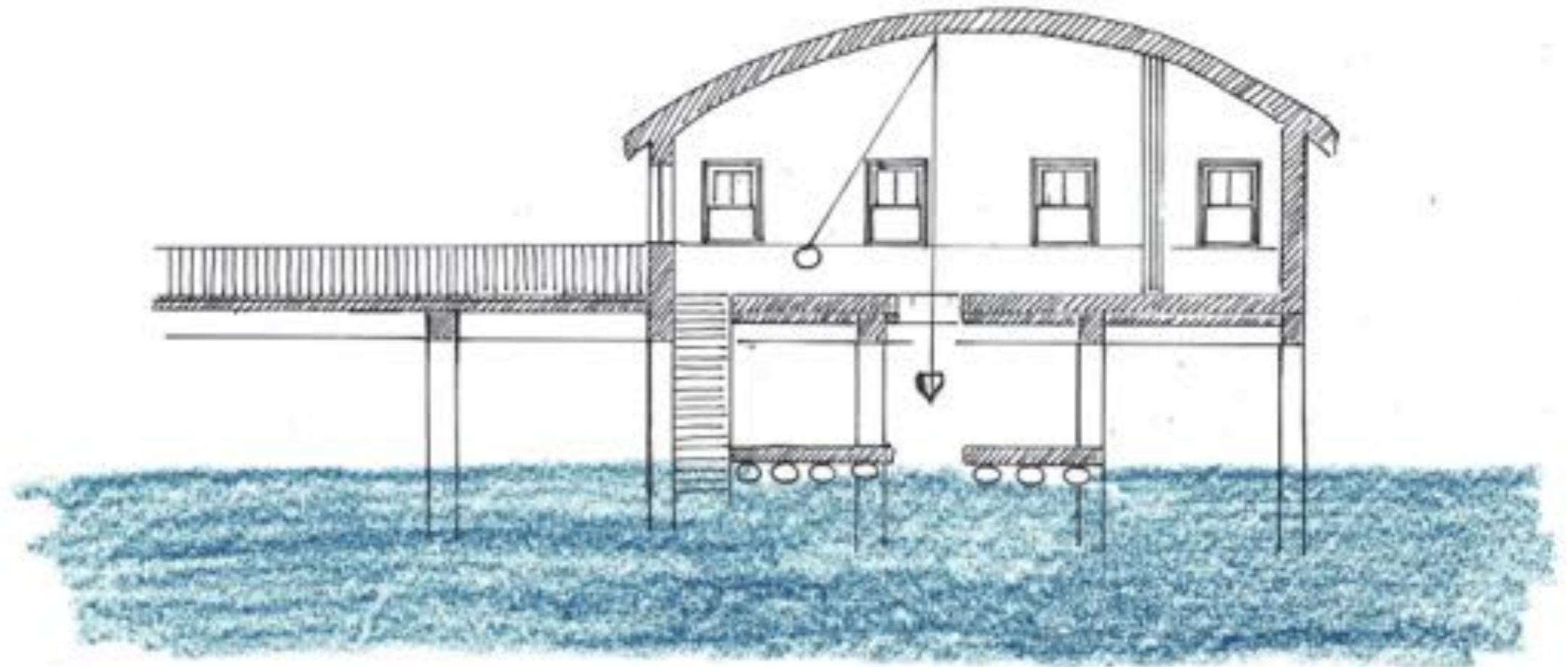
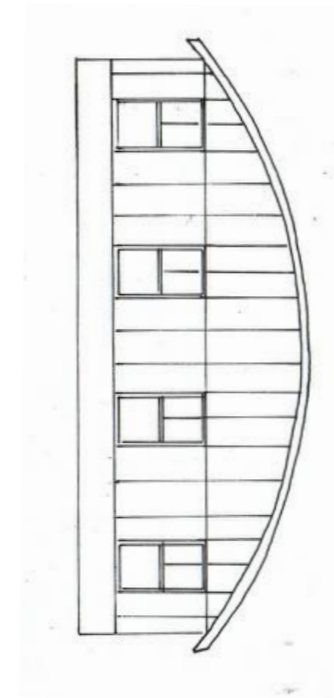
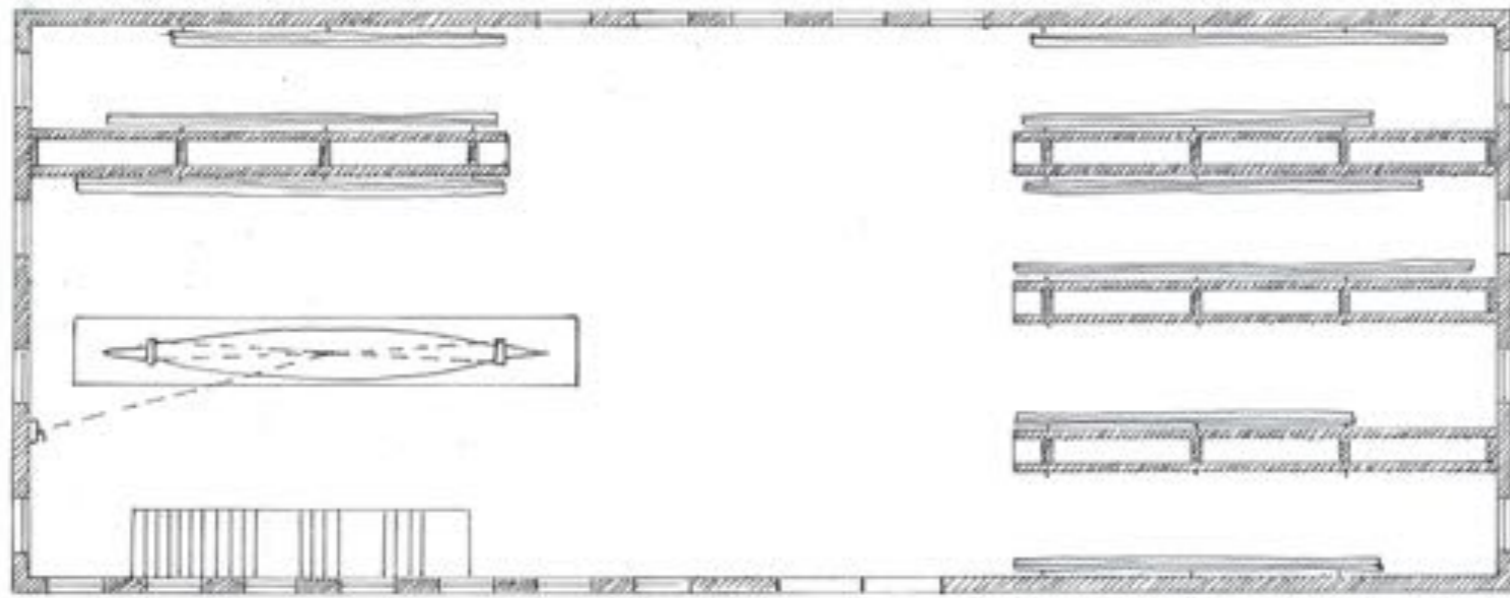









# Movement 2

## BE in CH

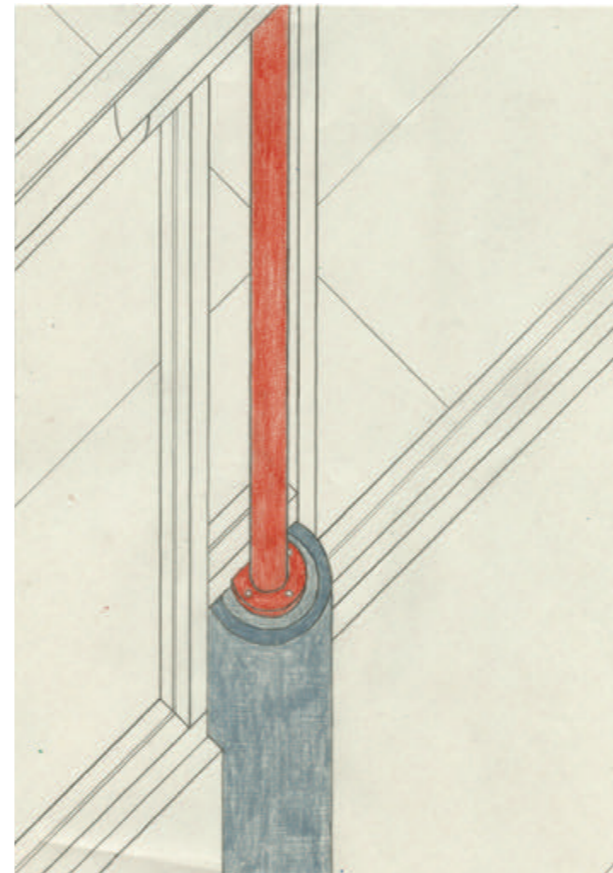
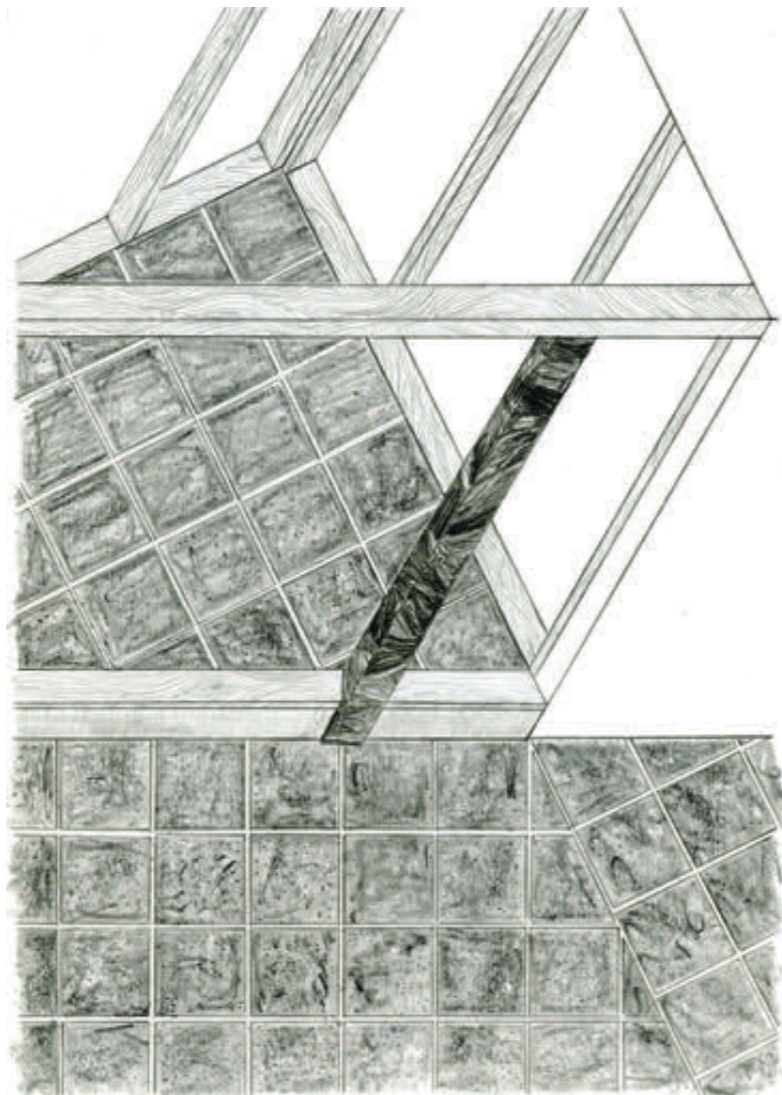

## House for the gardener

Impatiently I wait for my father.

I lie on my parents' bed upstairs.  
From here I can watch the way to the  
park of Villa Karma through the old  
larches.

Finally he comes back. Quickly  
I run down the stairs and go out the  
back door to welcome him.

Together we wash his tools and  
bring them down to the basement.

I can't wait to help out all day  
again during the summer holidays.



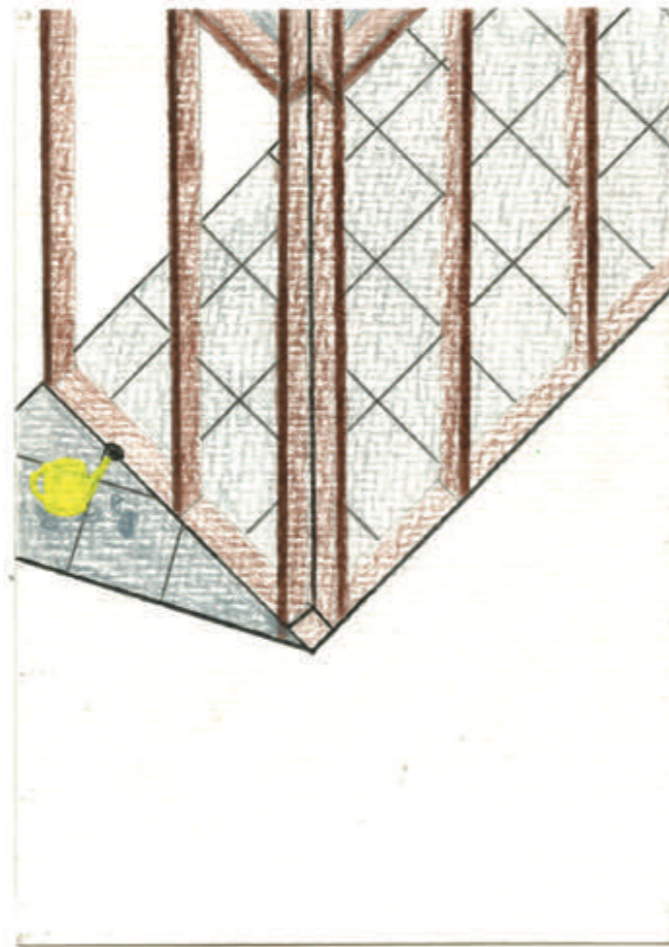
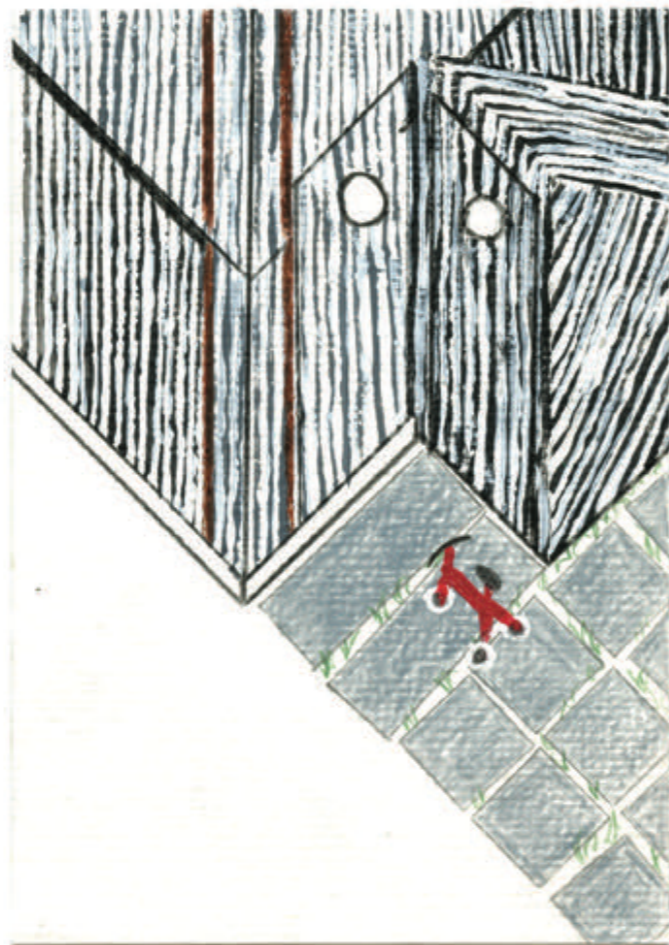
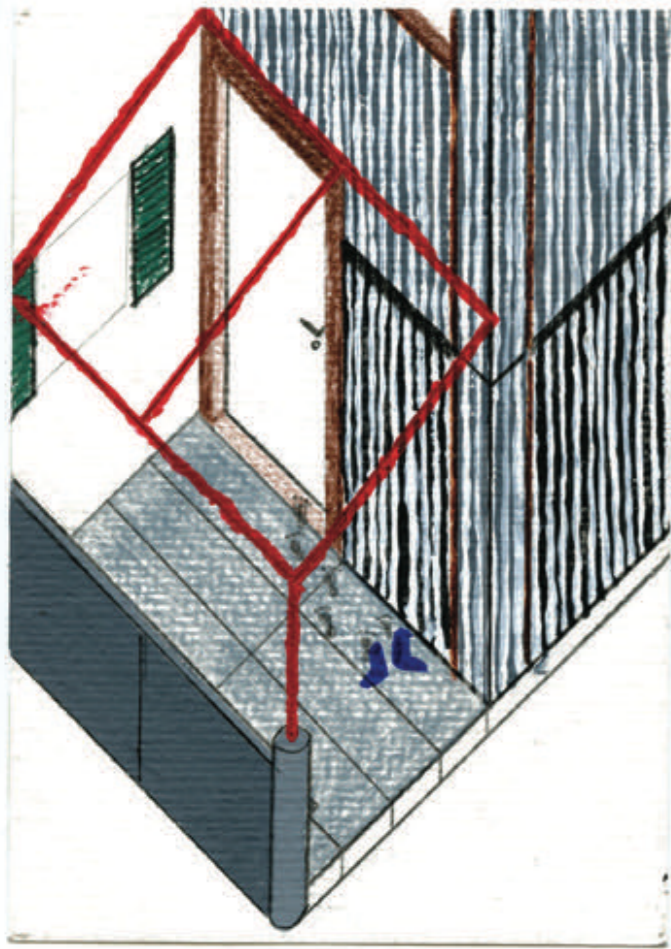

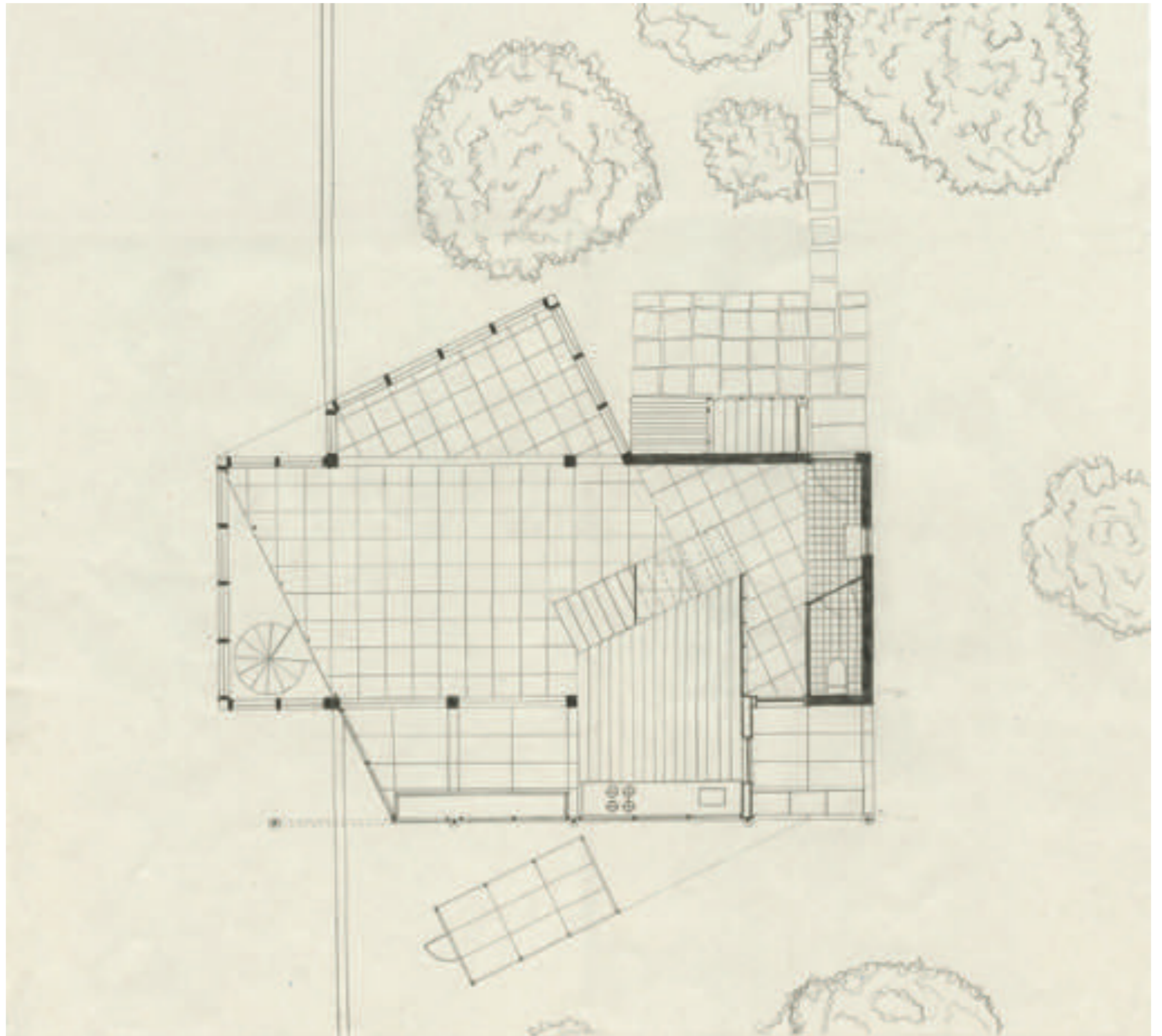
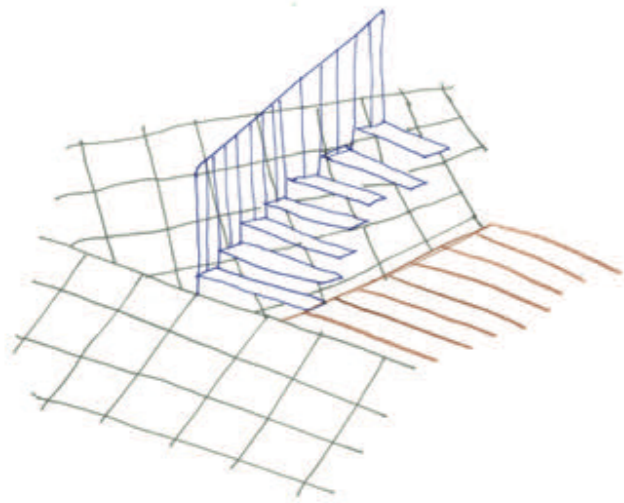
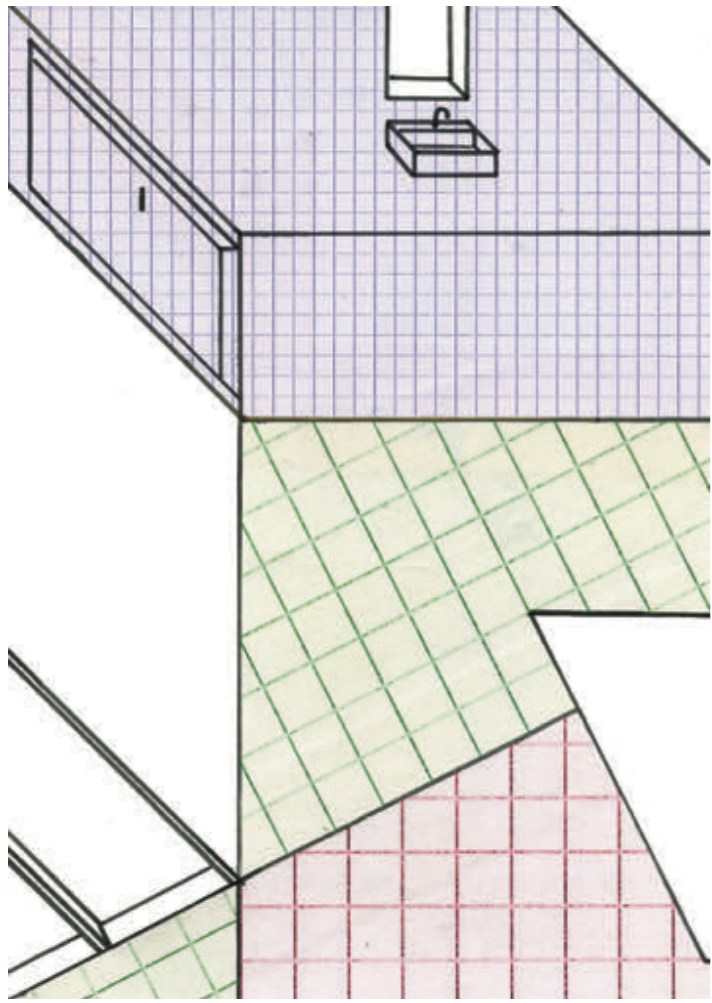





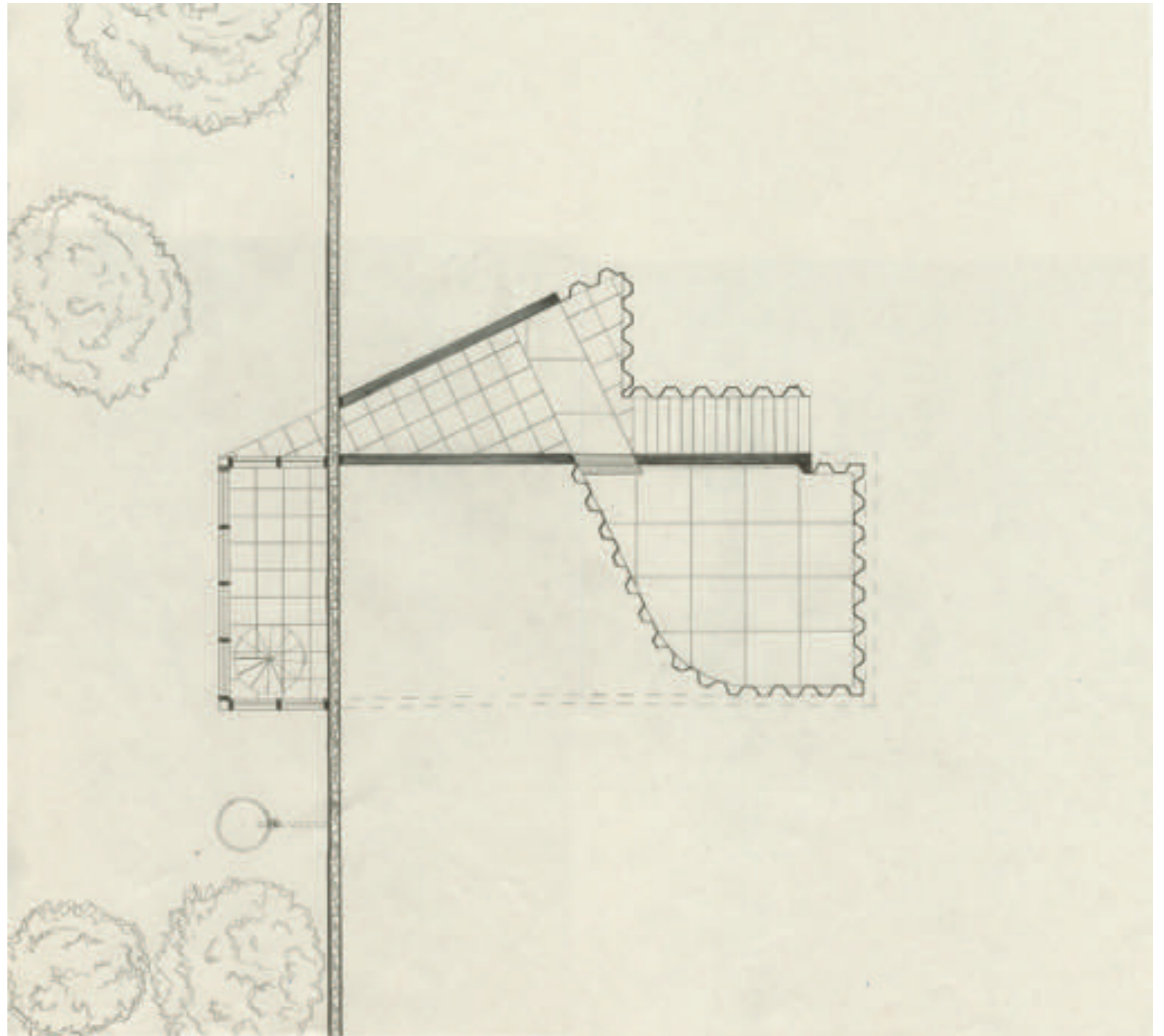



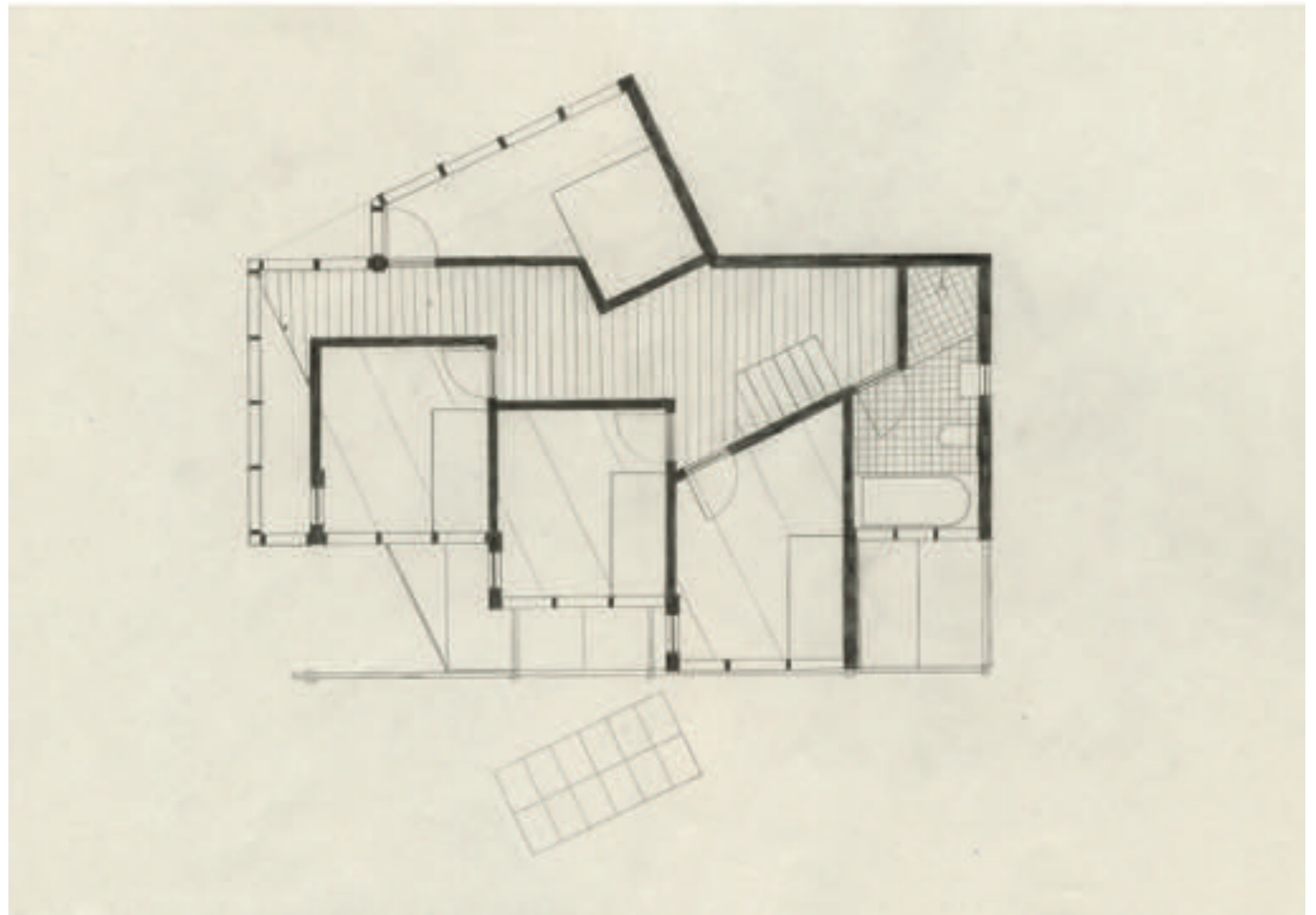



## The marble column

Today we have been invited to the Villa Karma for a afternoon tea. Already as we walked over I felt that the attentiveness of the children grew with every step.

Finally by entering, they were really agitated and quiet. What a magical place that can silence our kids.

But still, non of us felt very welcomed here.

We love that our small home is light flooded, precisely designed for us and embedded in the surrounding nature. Nevertheless I realized that my wife fell in love with the black marble.

To surprise her, the little ones and I decided to bring a piece of this beauty in our home and painted the central column in faux marble.



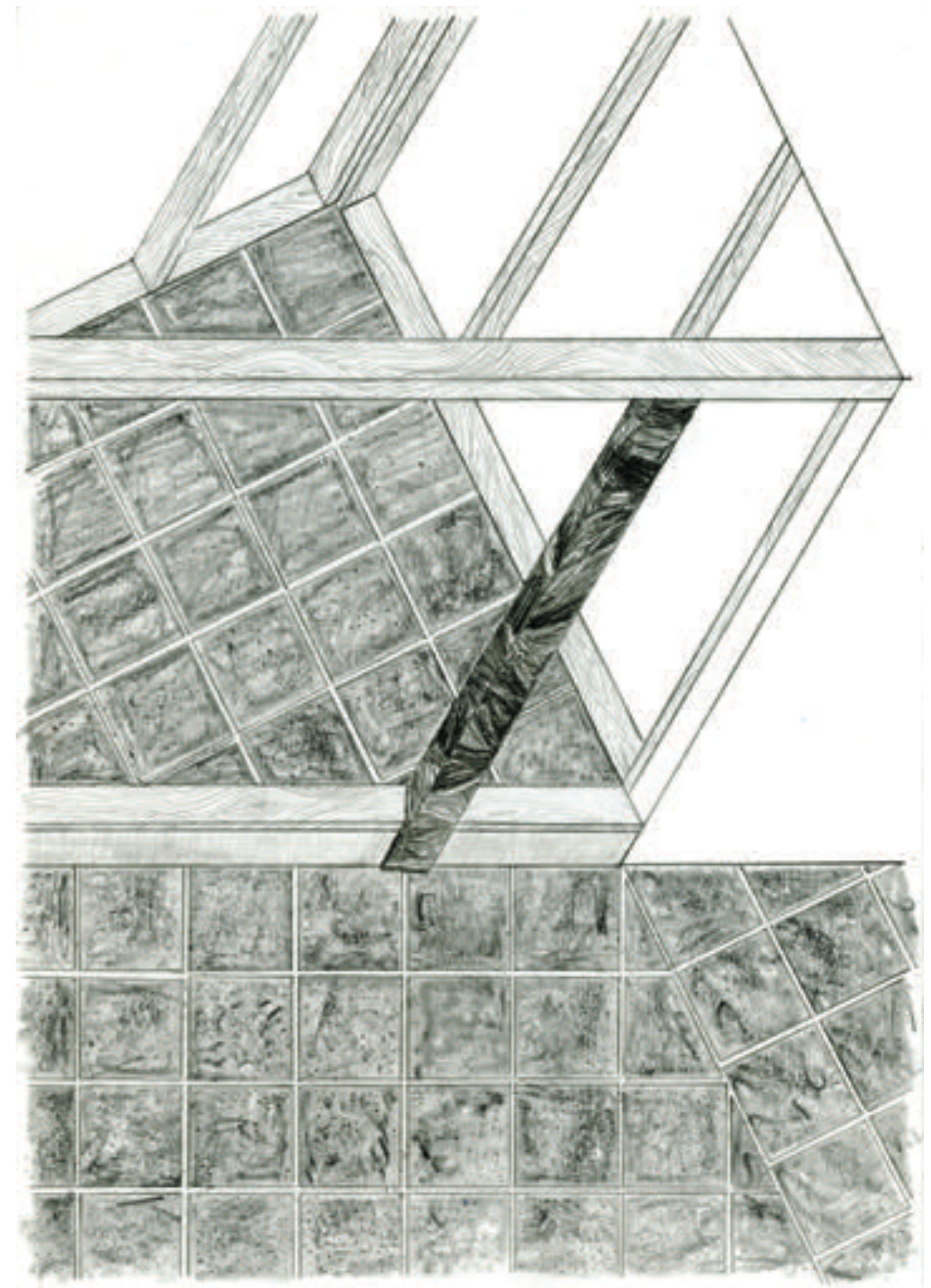

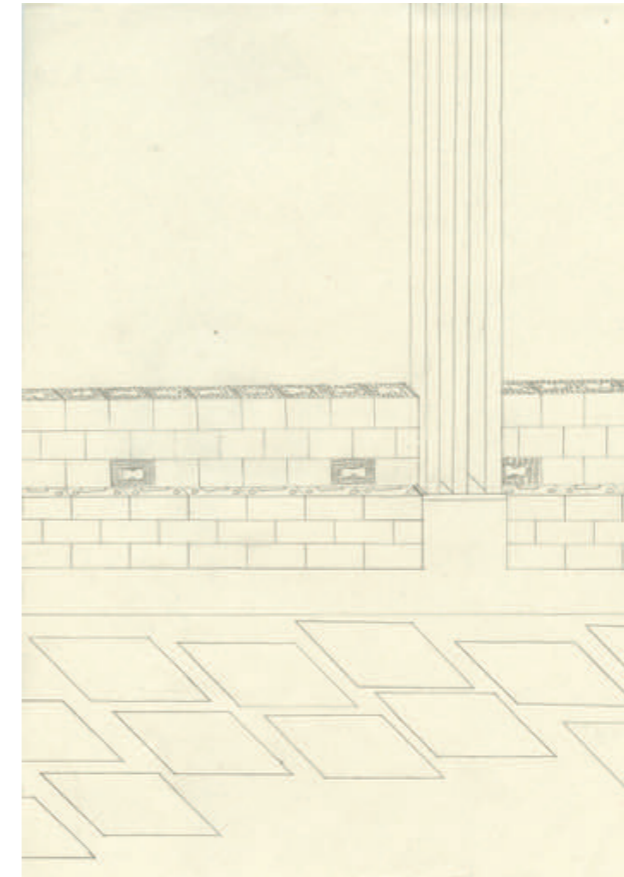
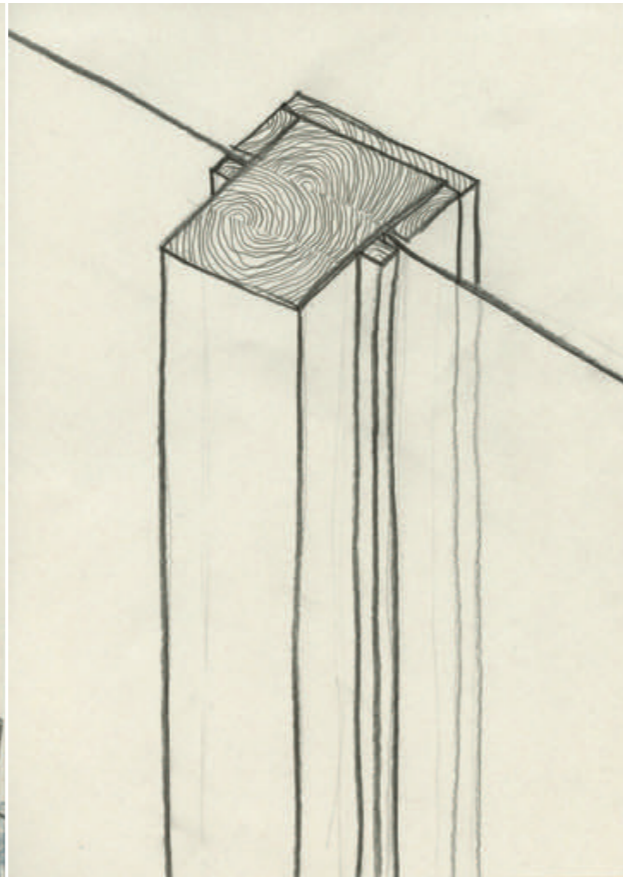
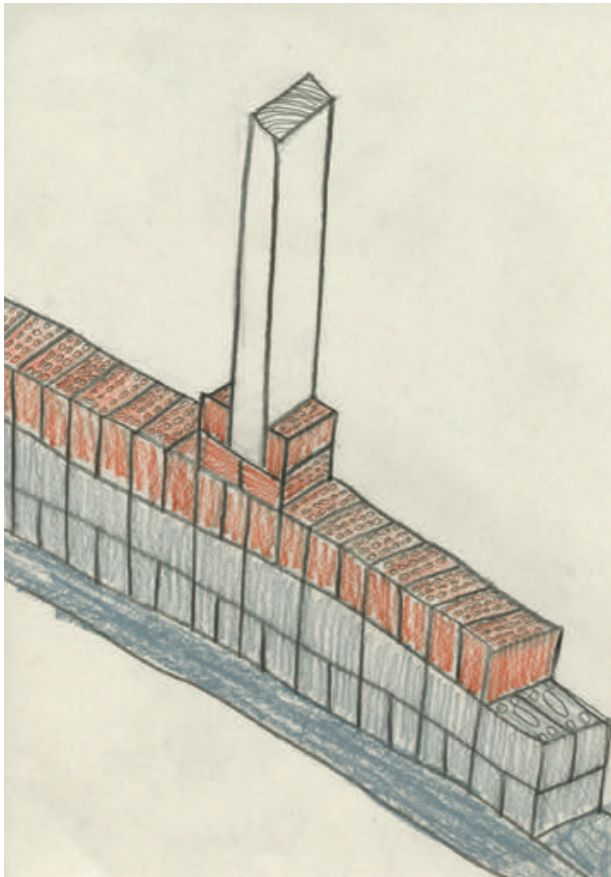
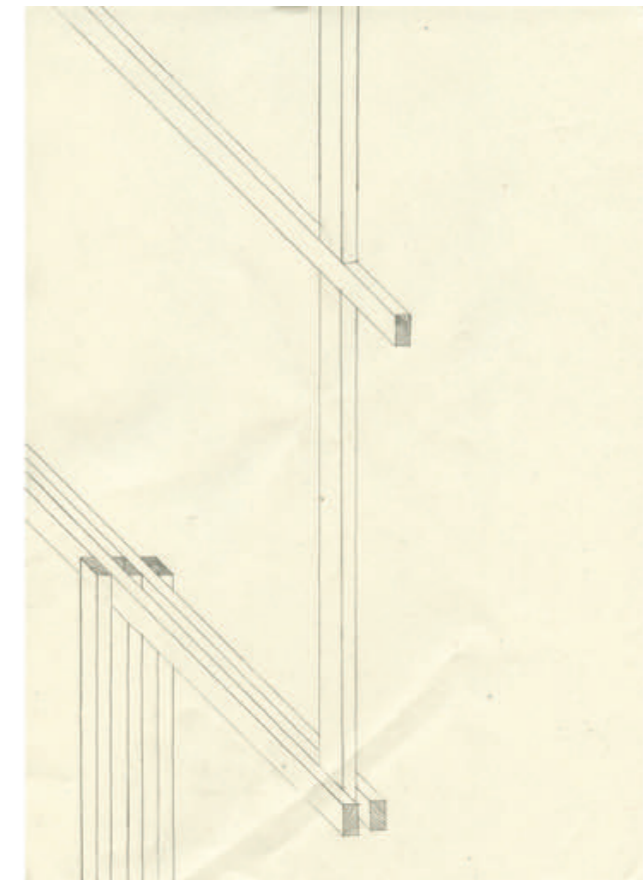
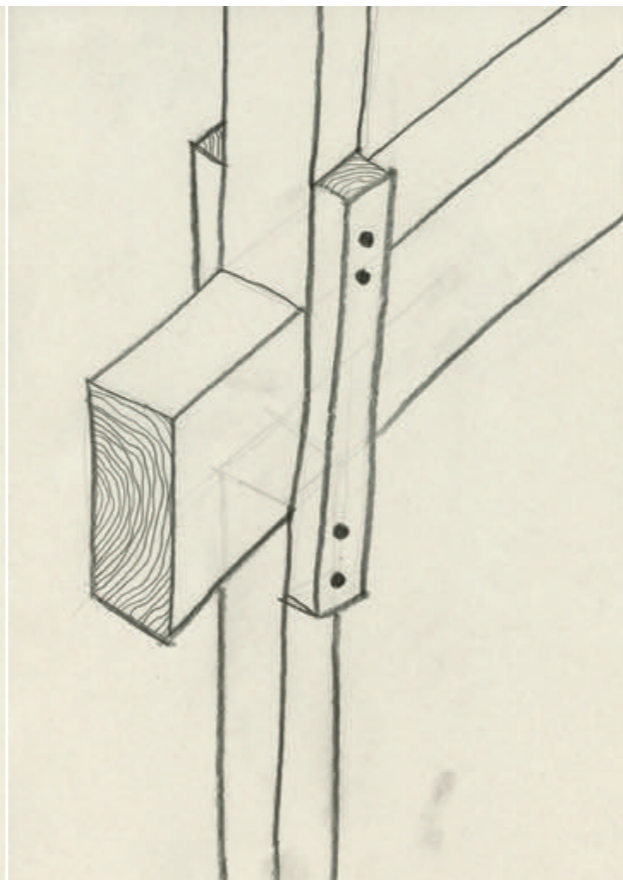
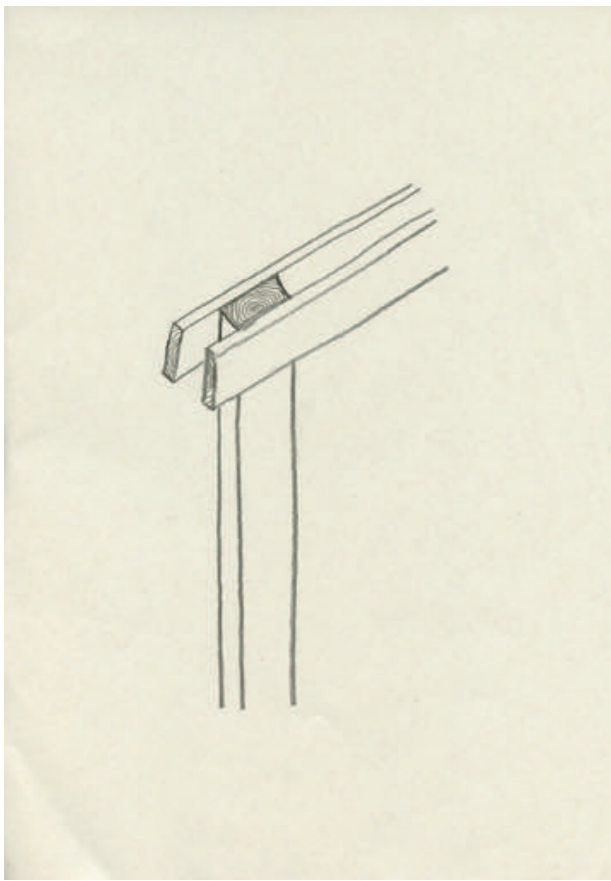

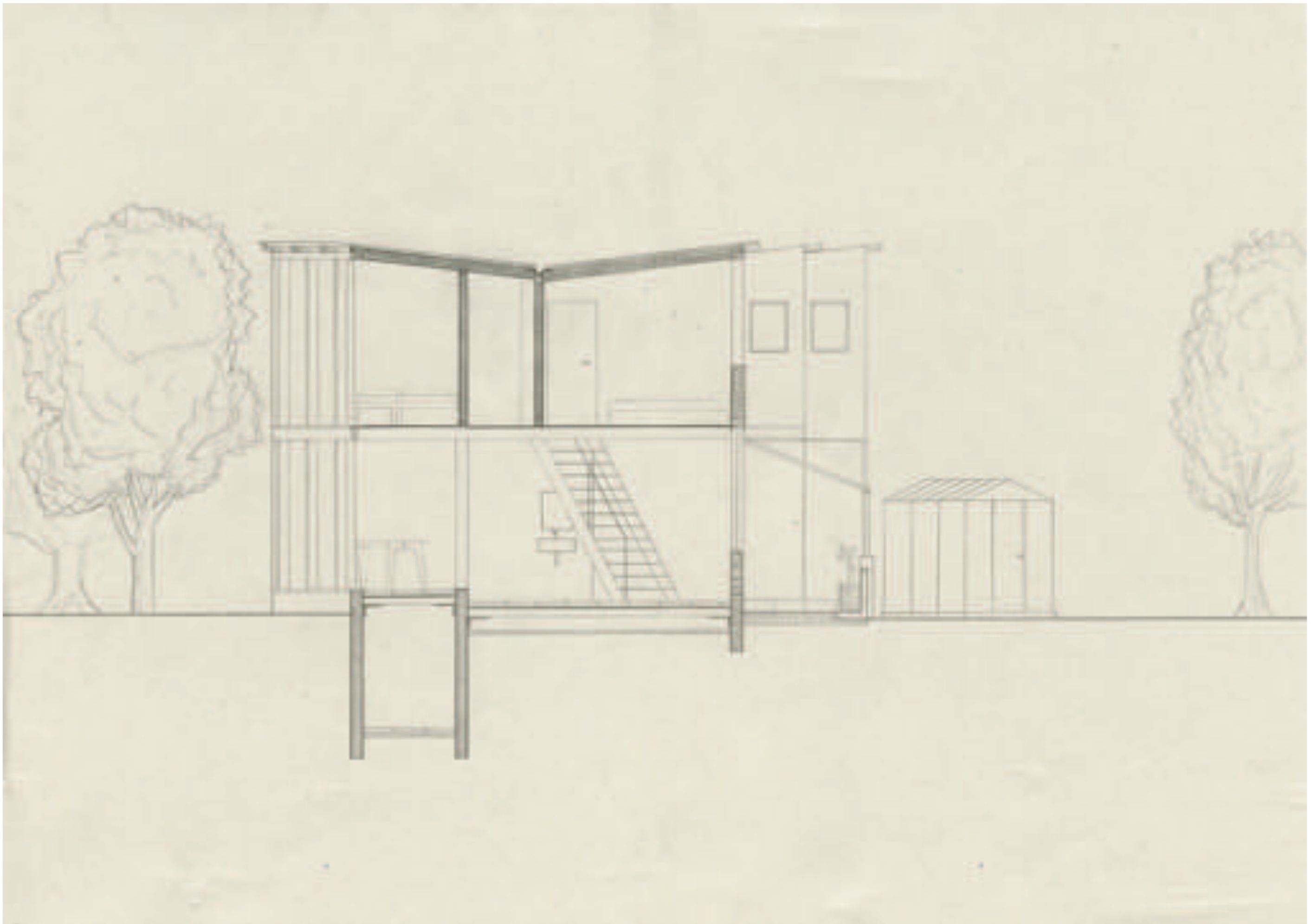

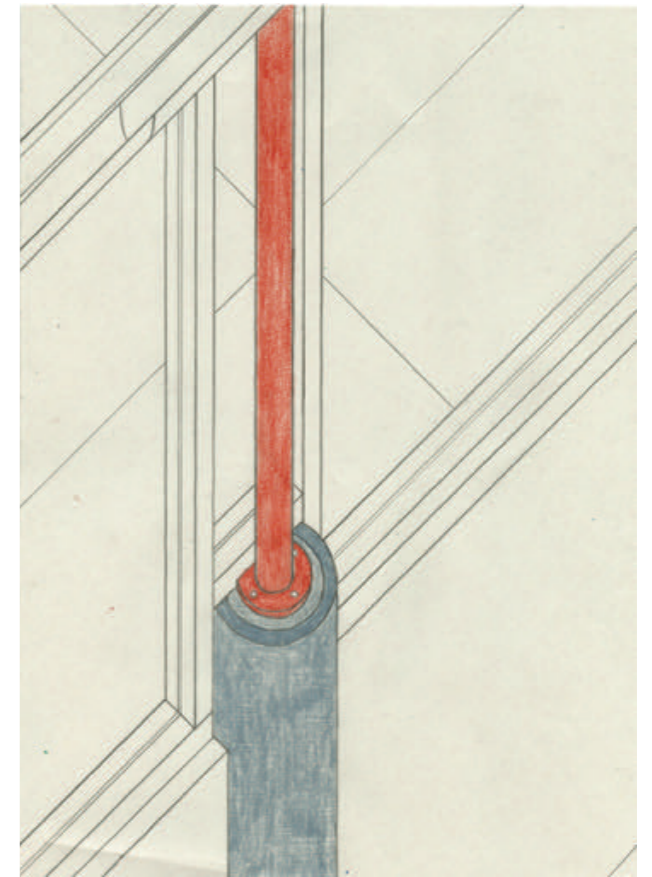
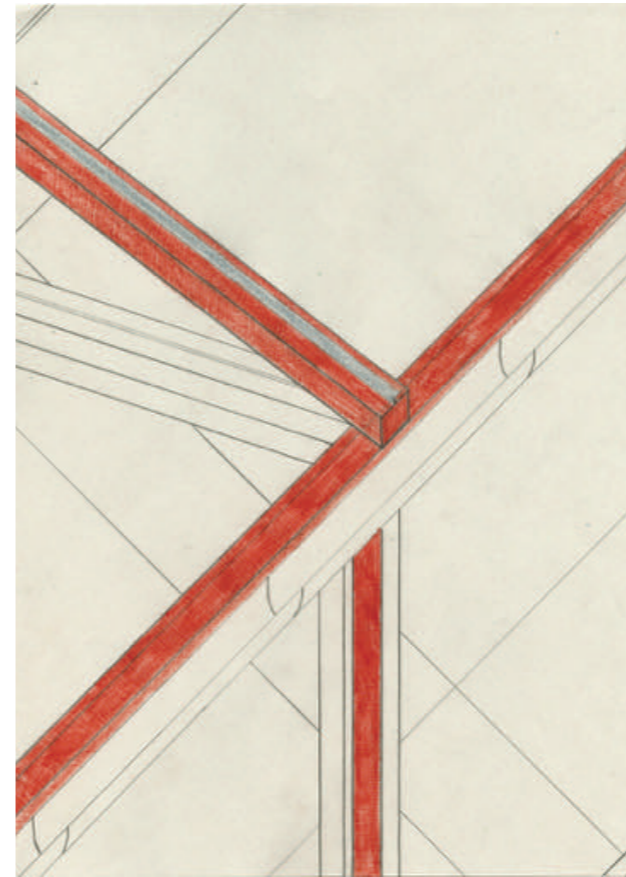
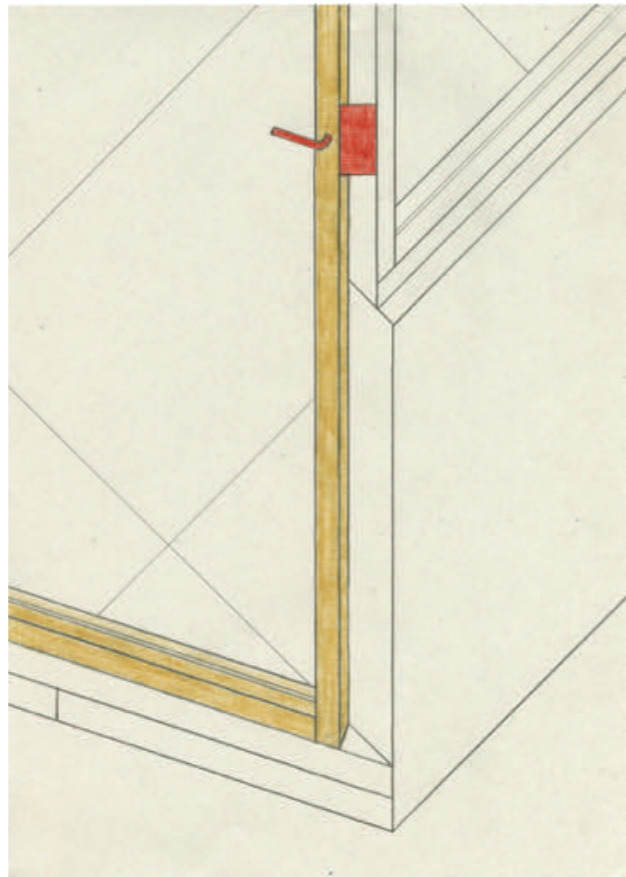
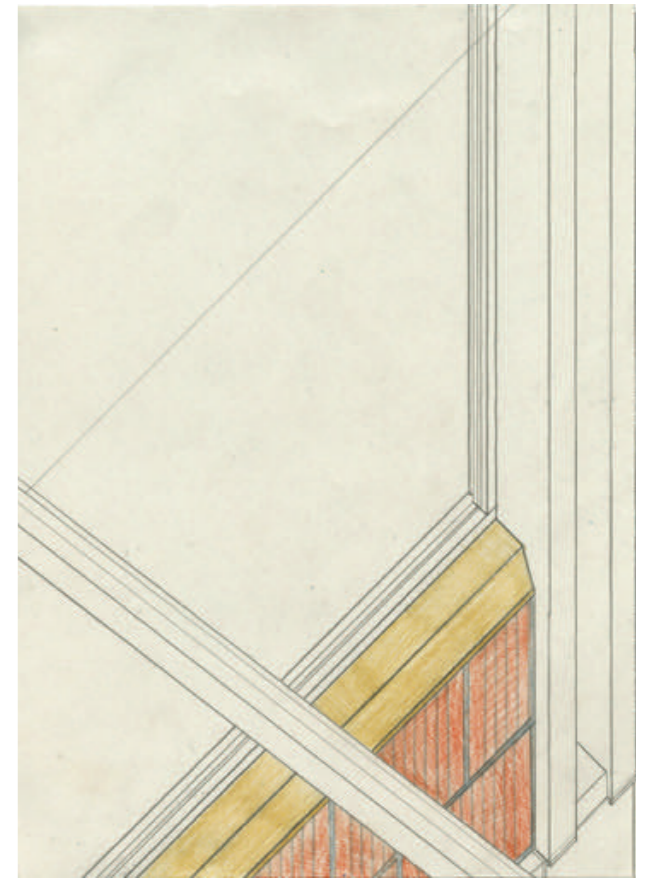
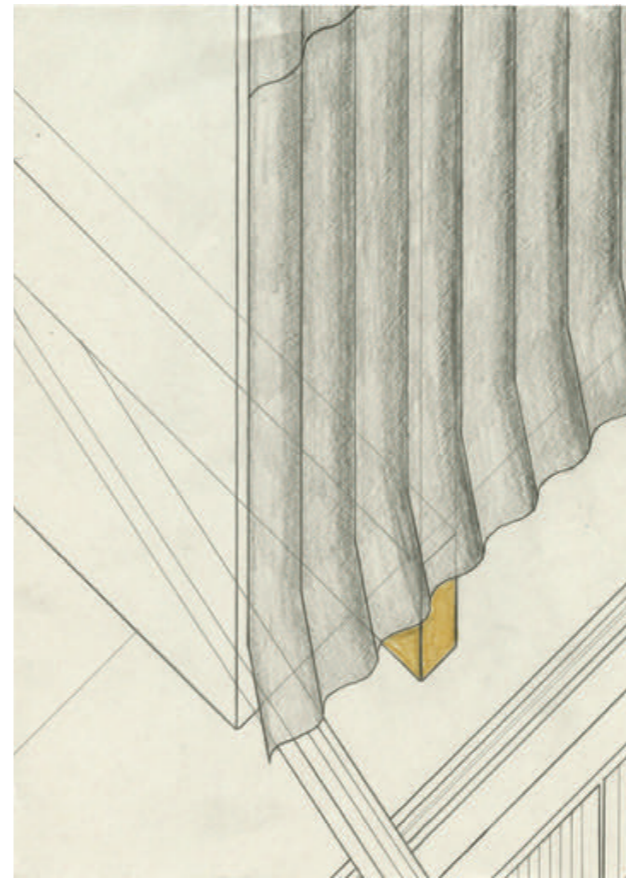
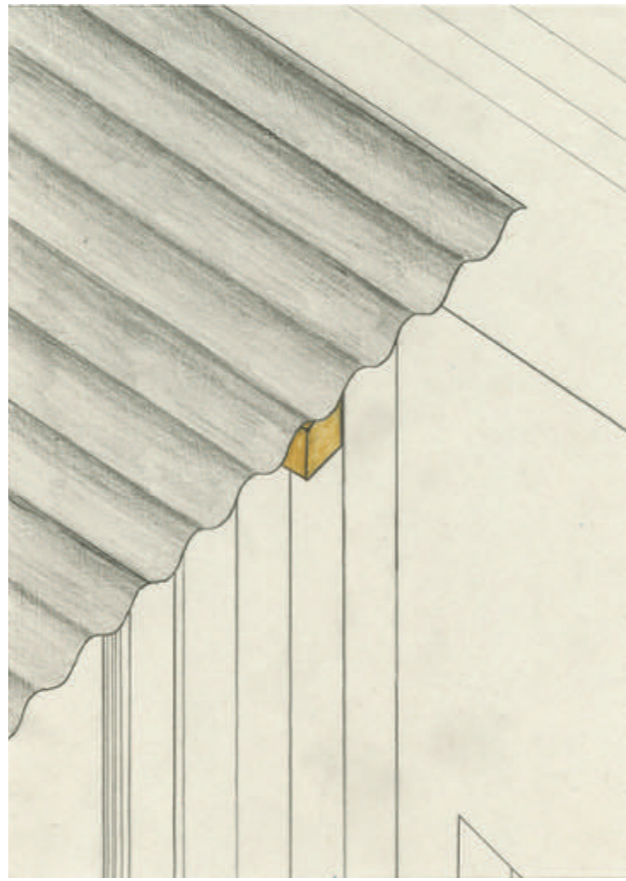
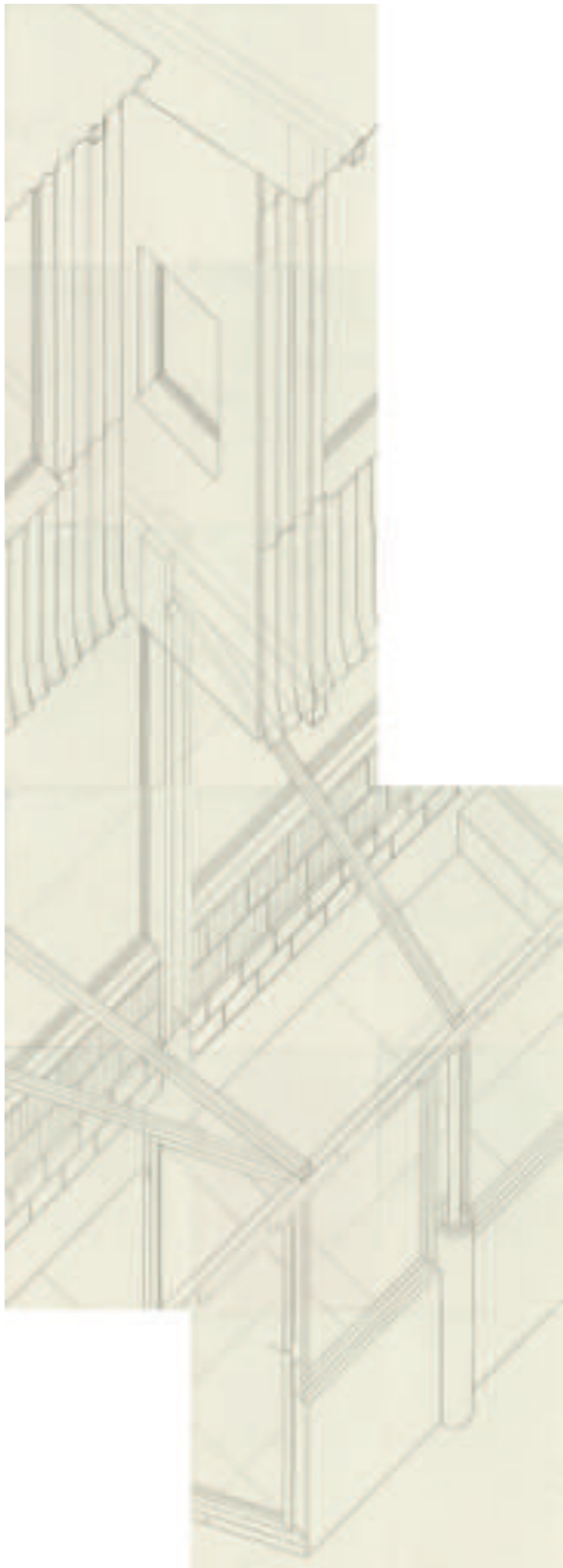

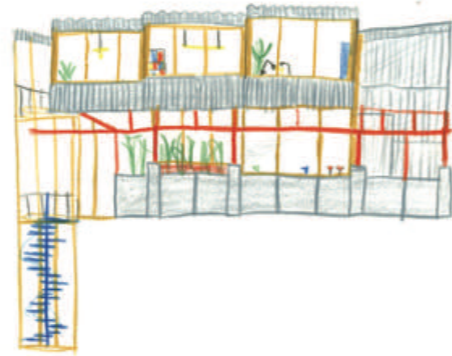
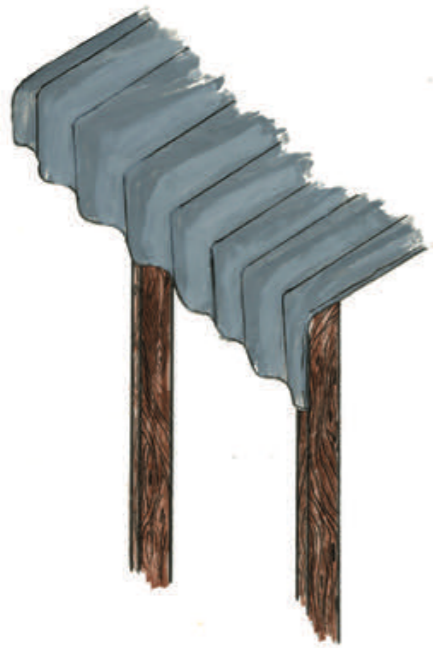
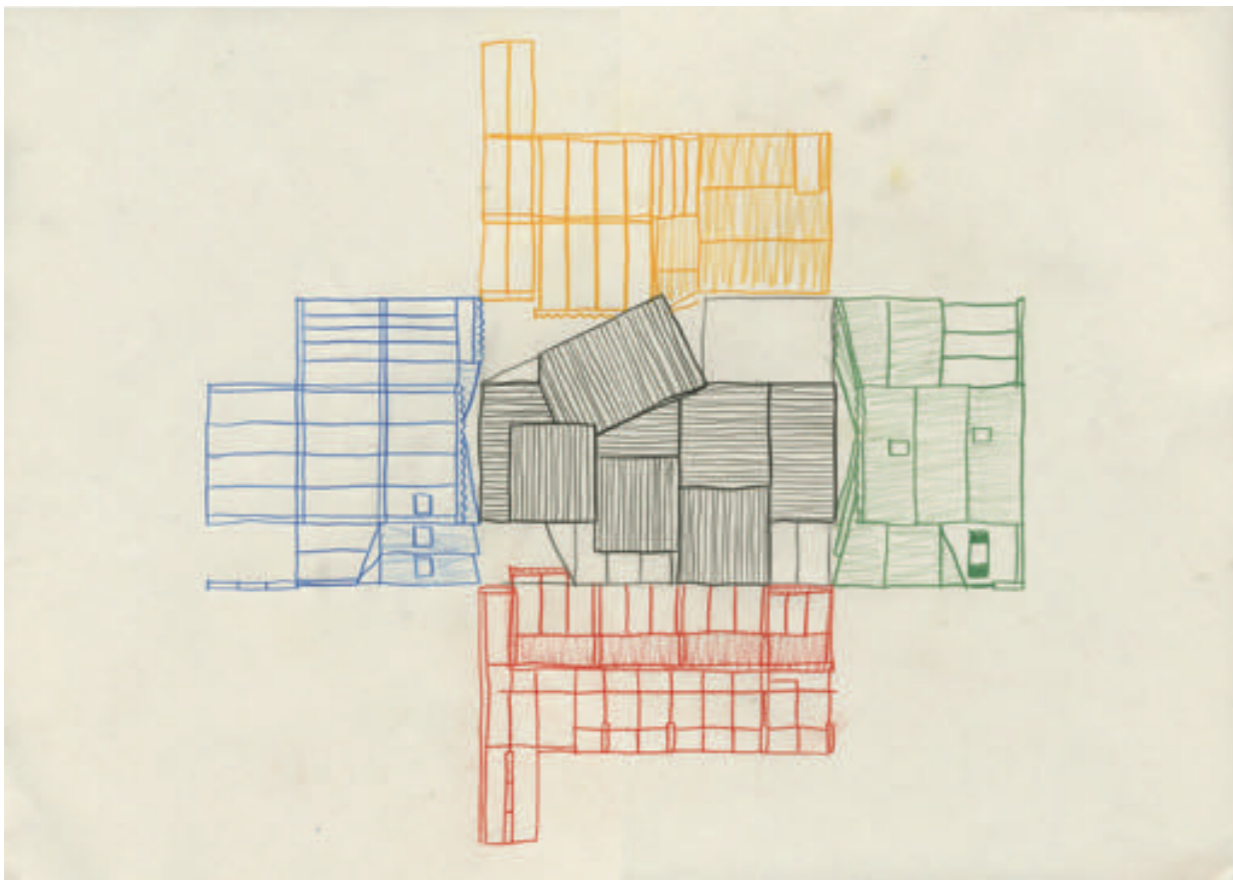





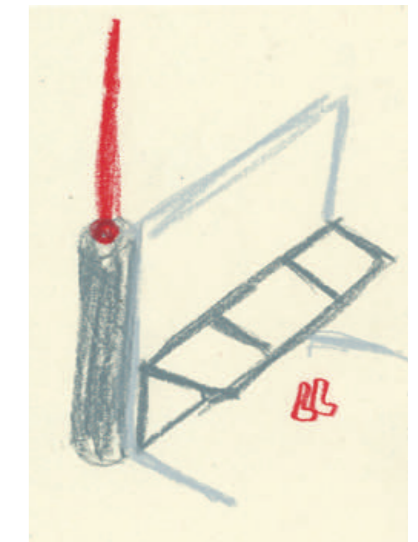
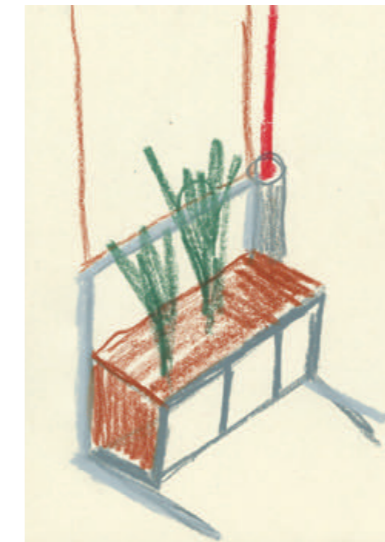
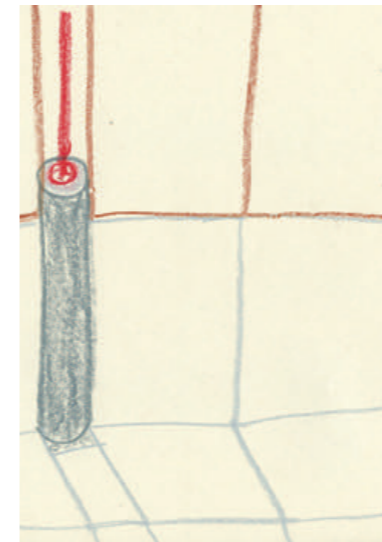
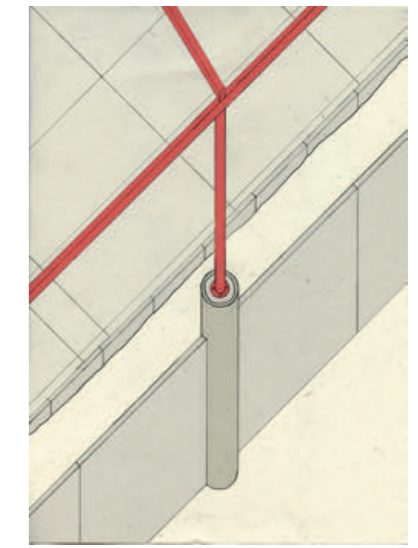
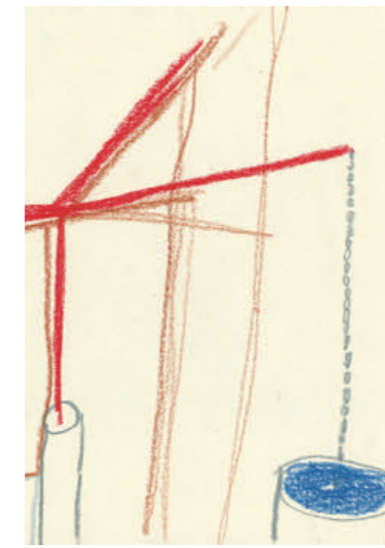
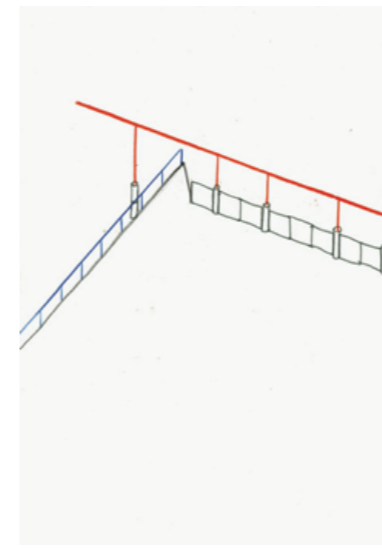











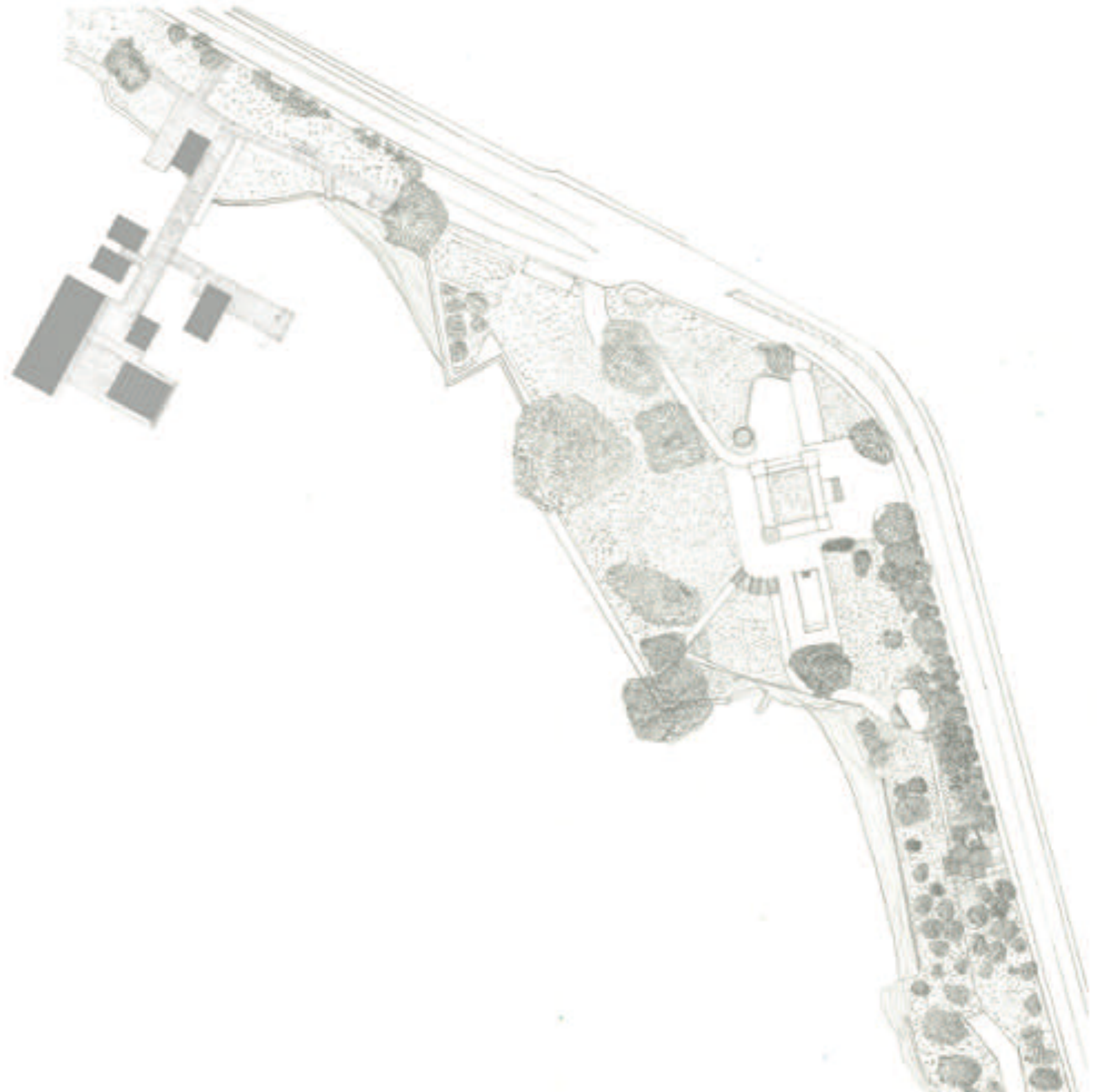



# Movement 2

## CH in US

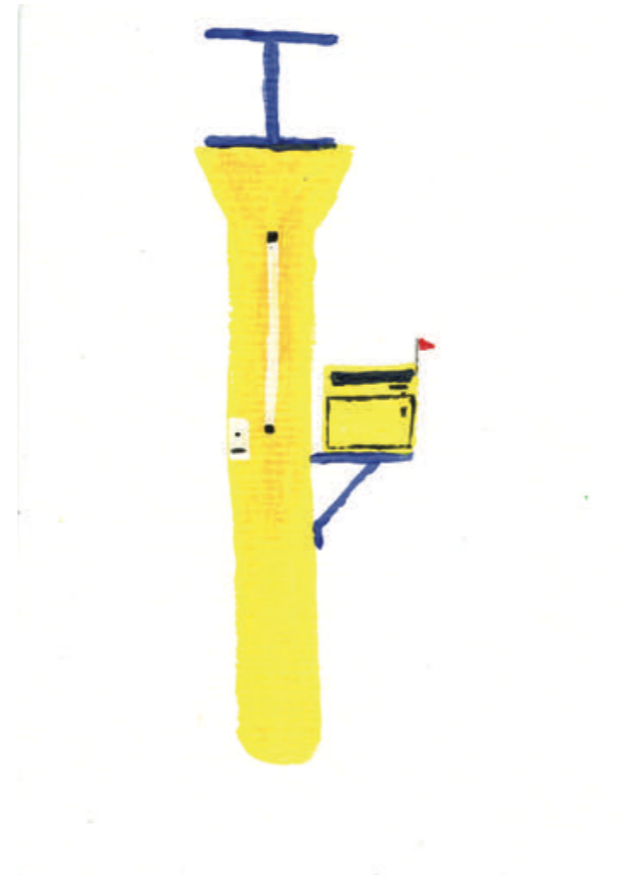
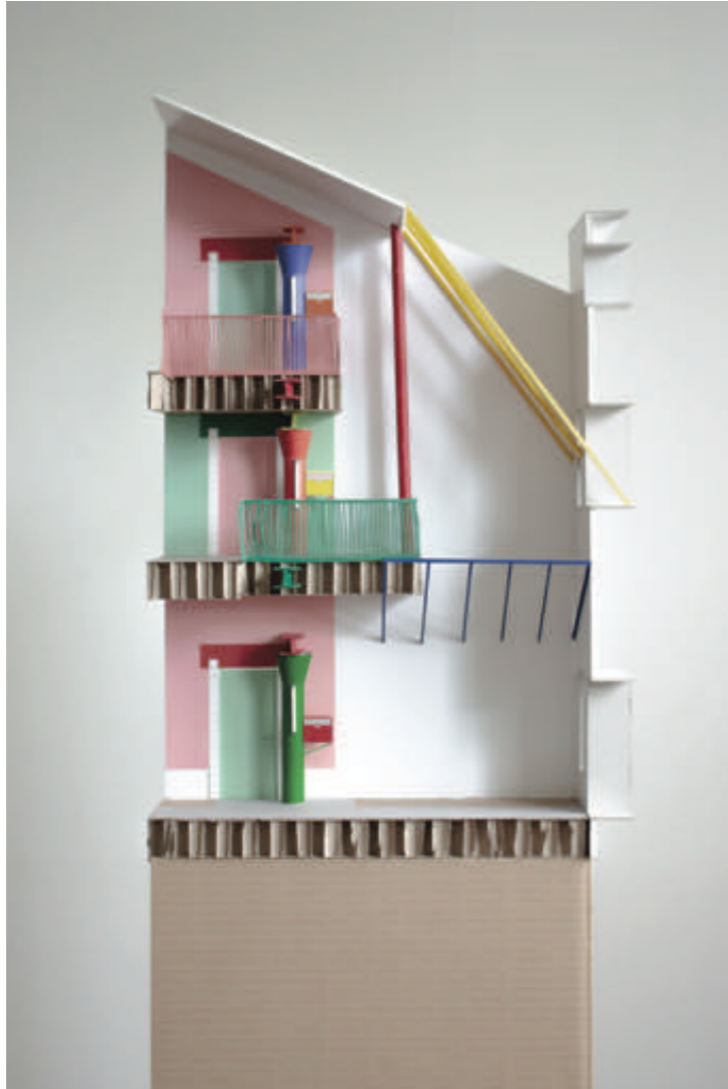

## The last Shaker

I was raised in this house. We were a strong community then, just like today.

But there have been times when it became empty here, partly I was the only shaker living in this house.

In the meantime a lot has changed.

First I was very skeptical when I heard that my village is being altered, but it was clear that something has to happen. But meanwhile I actually like it almost better than before.

I appreciate that our buildings have been given a contemporary touch. In this way it has been possible to bring a new community to this place, which for hundreds of years was shaped by the common ground.





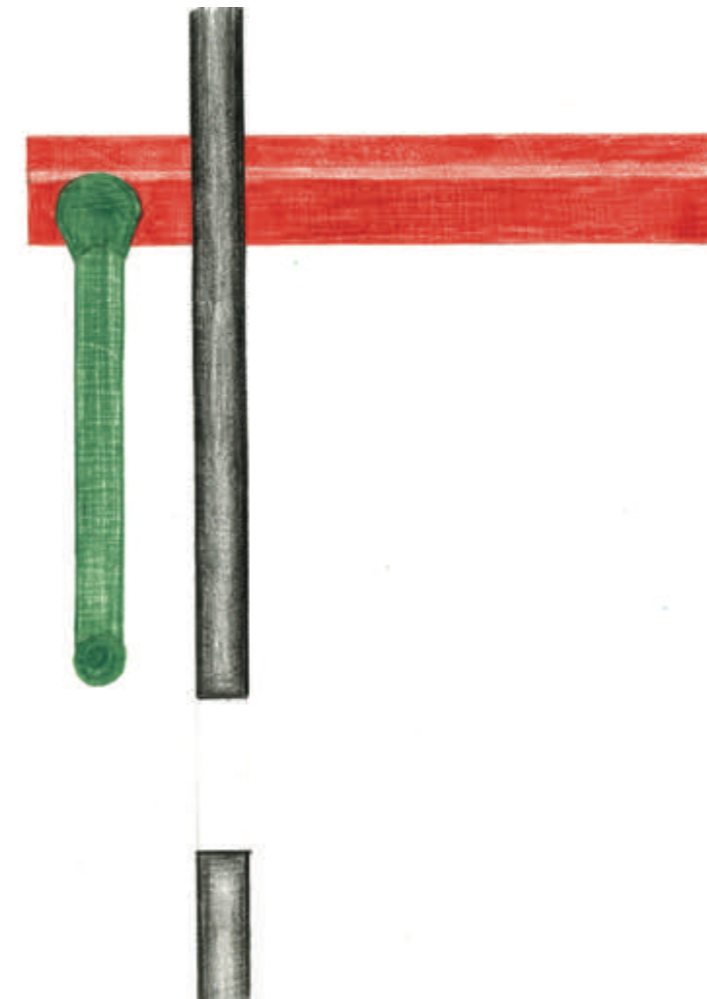

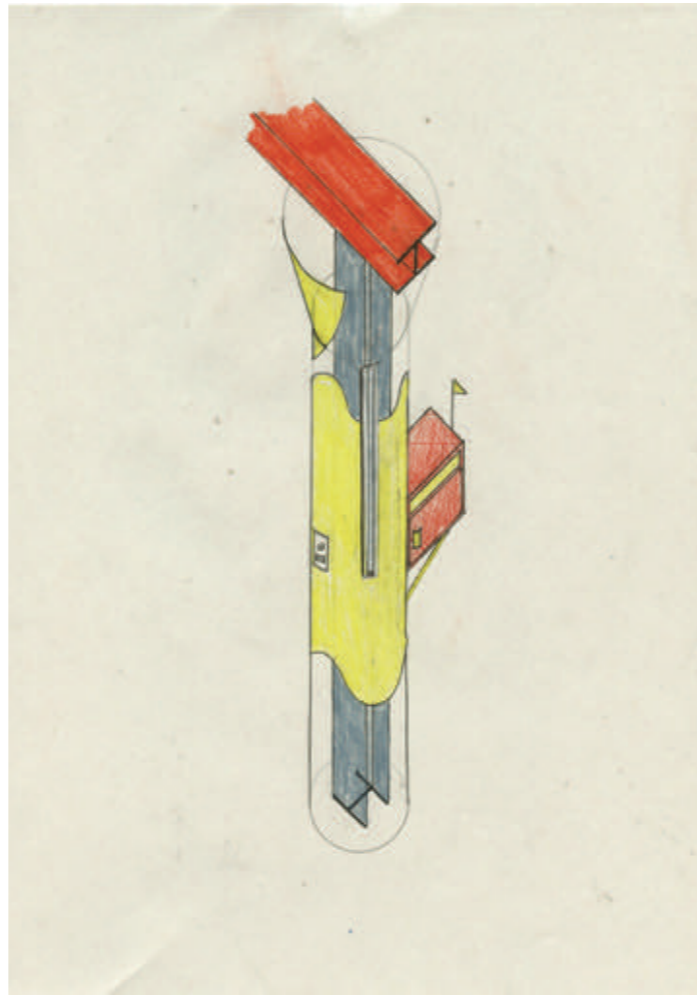
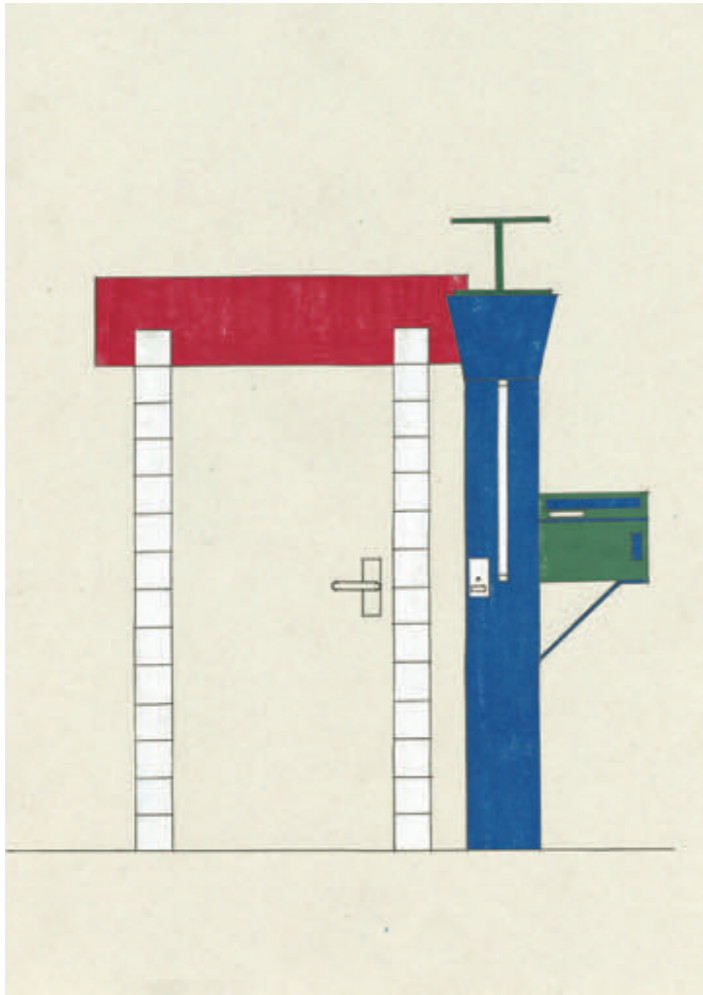



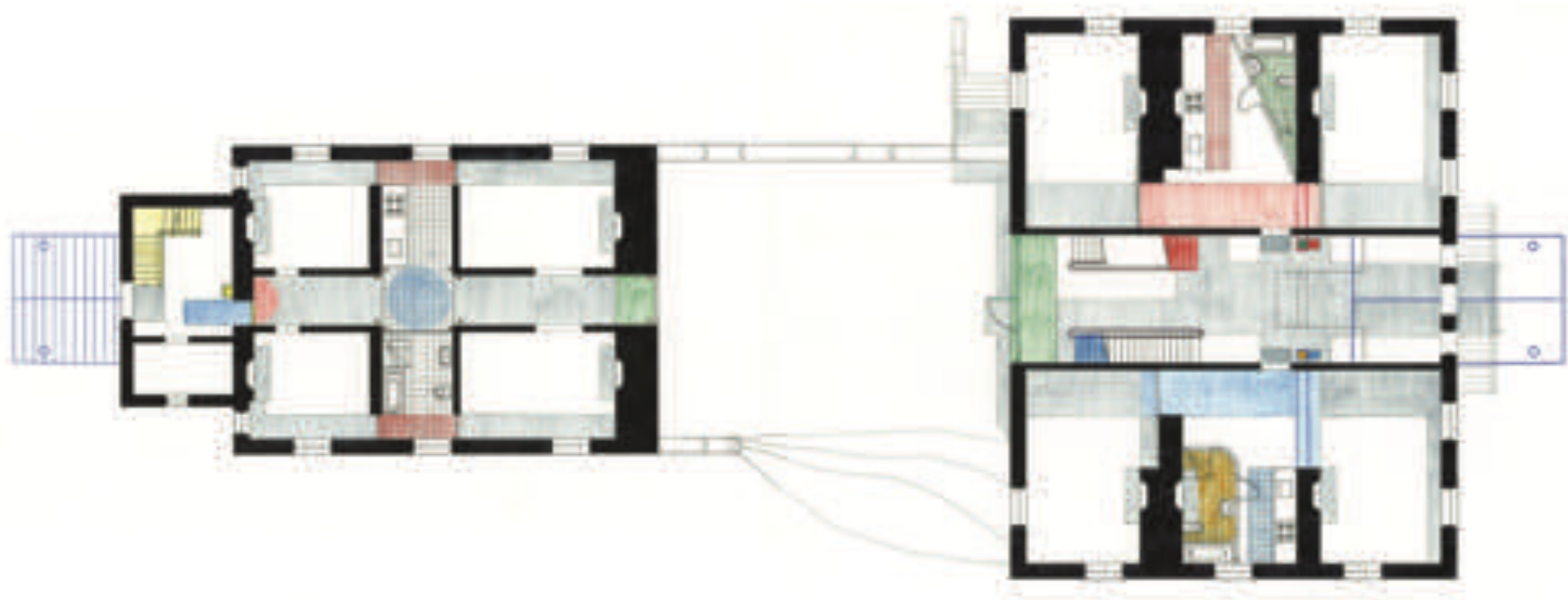





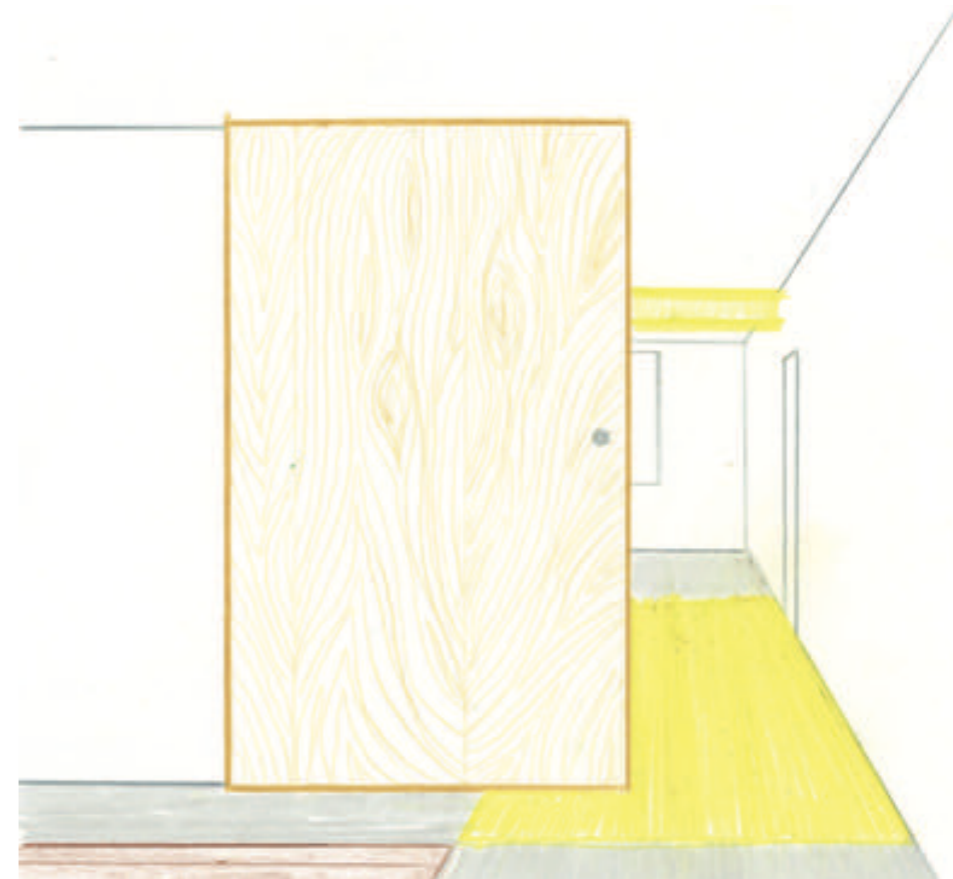
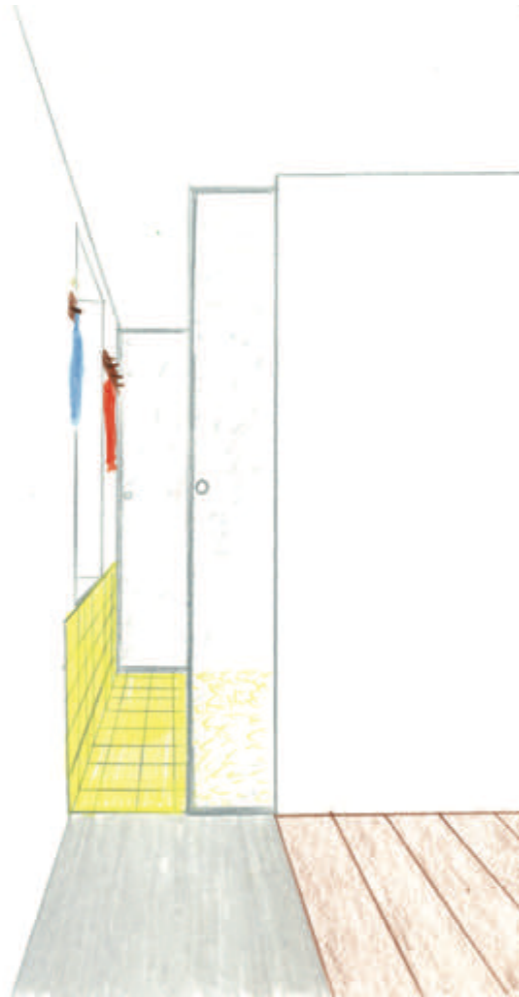

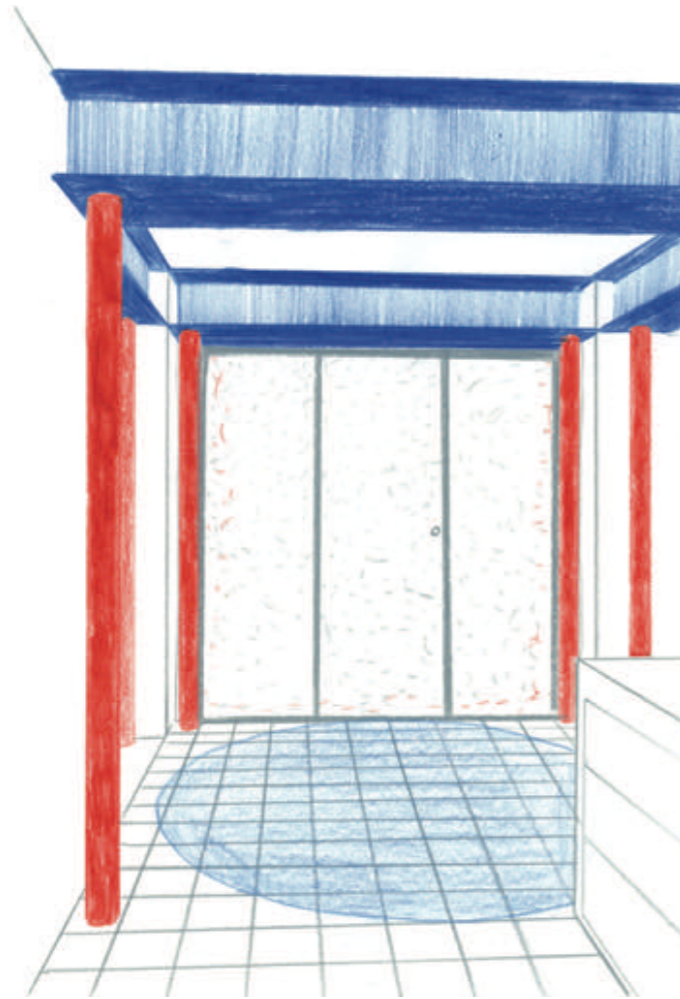

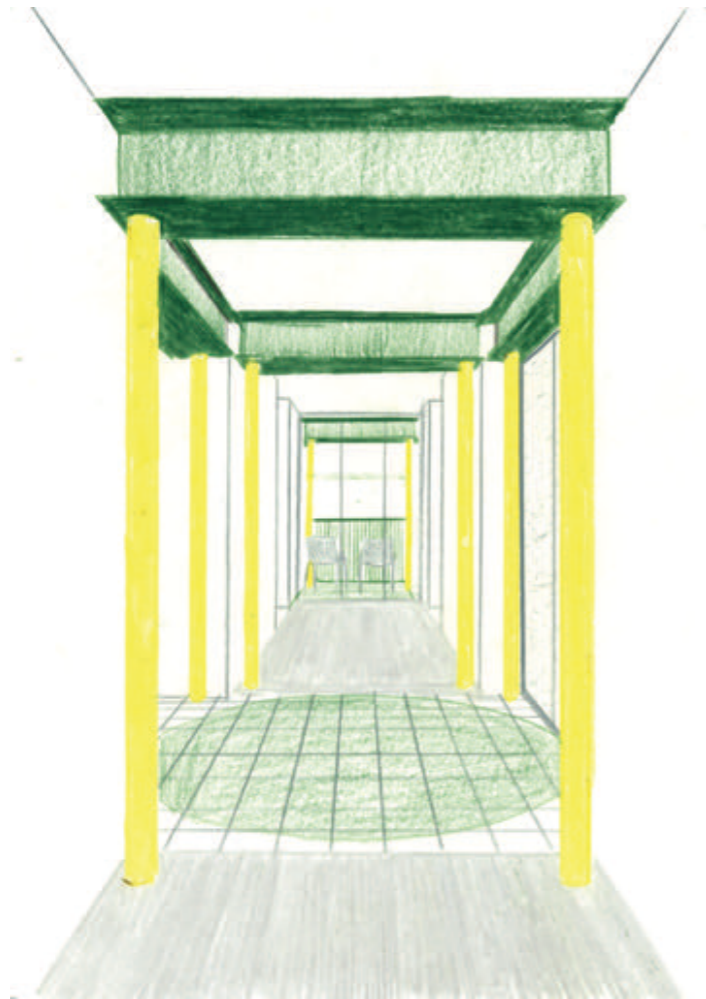

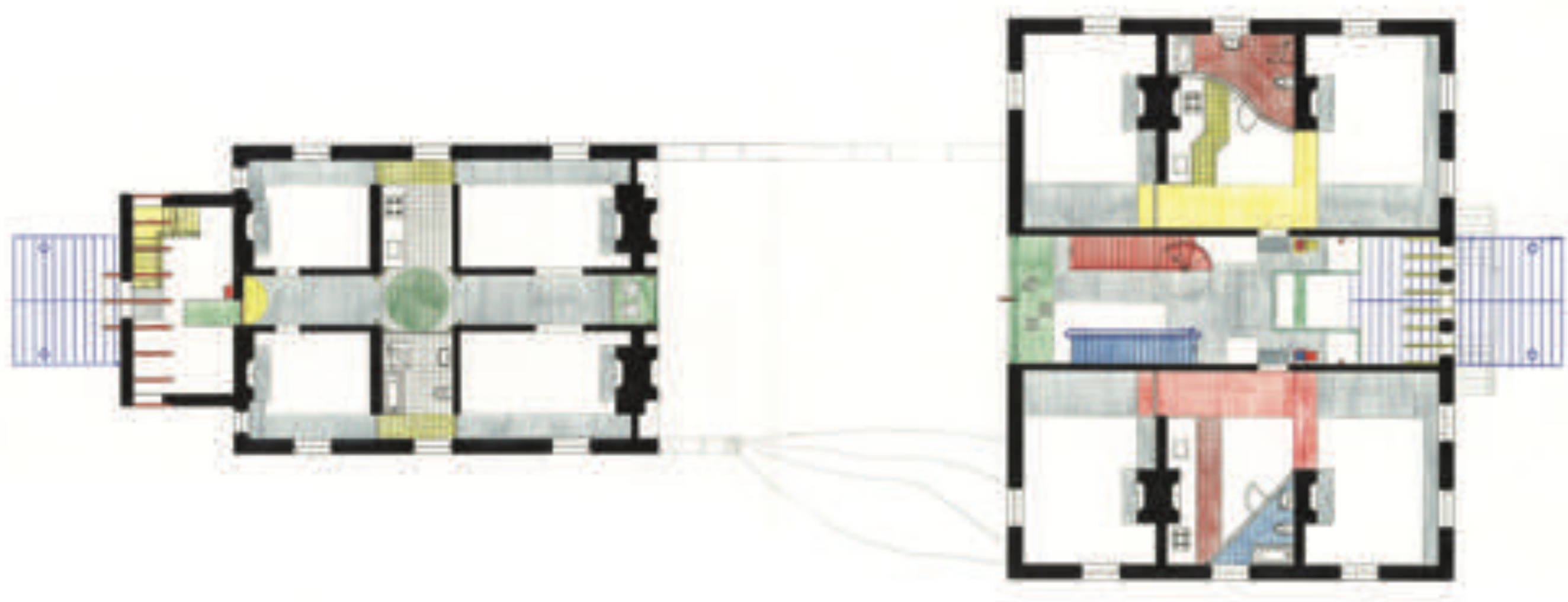

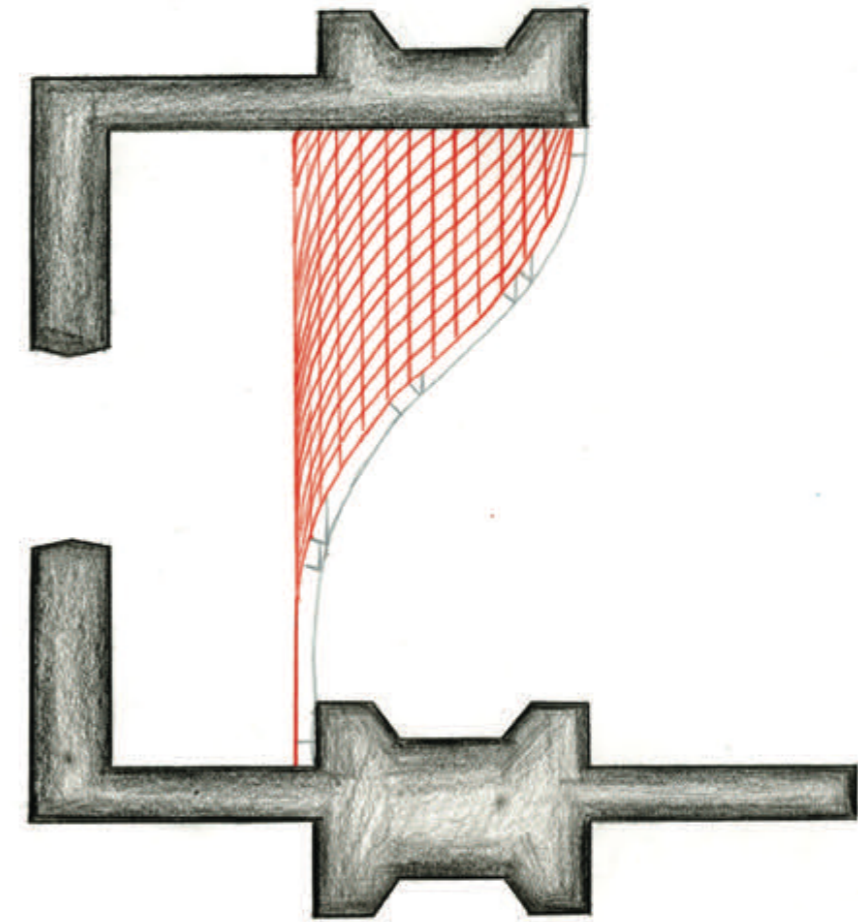
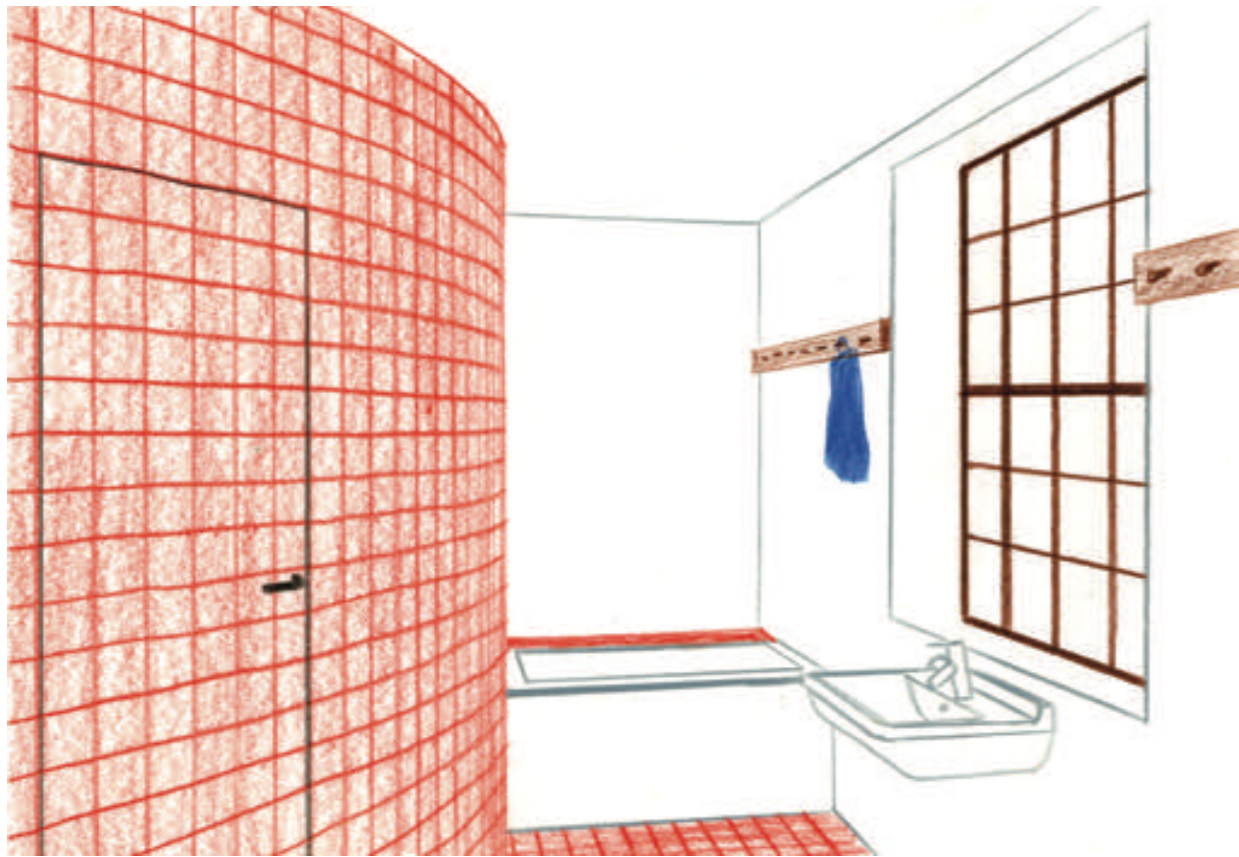





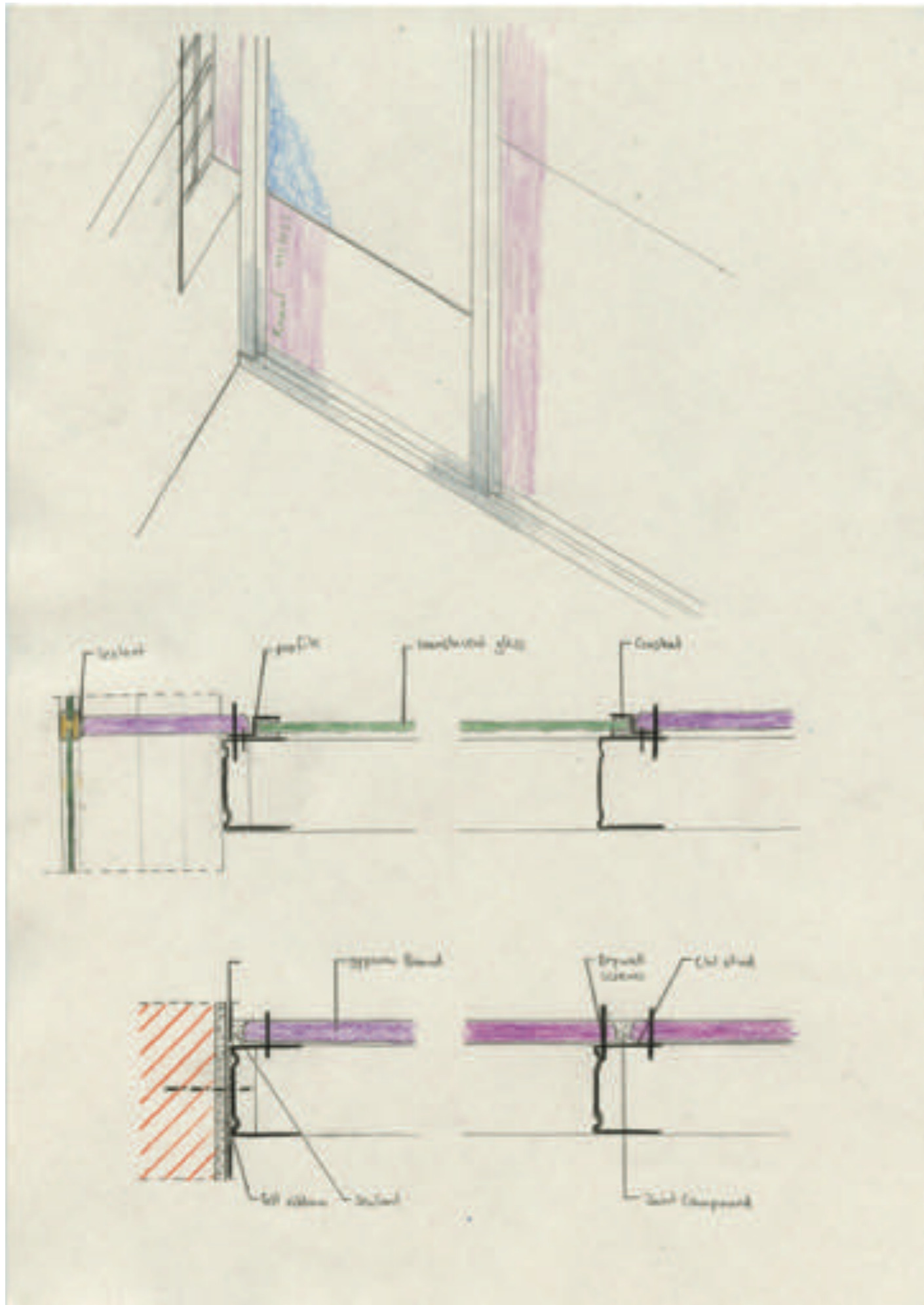



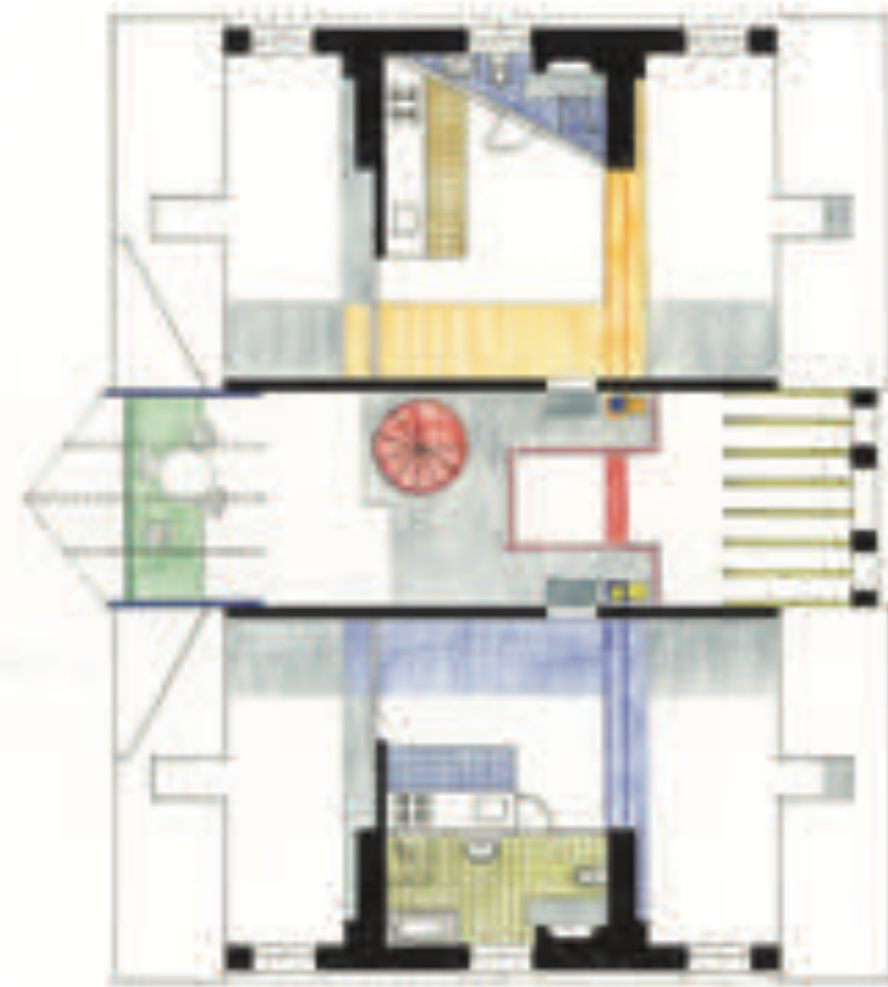
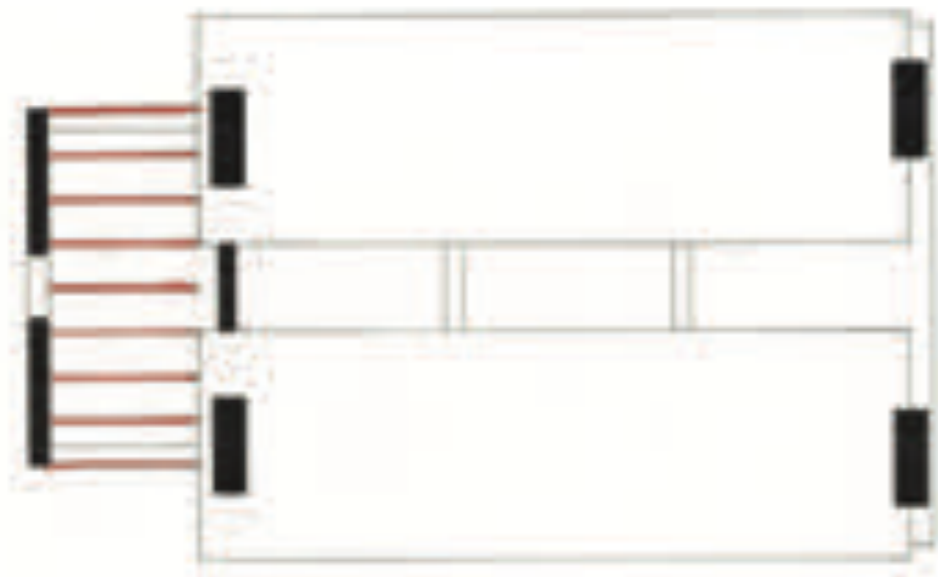

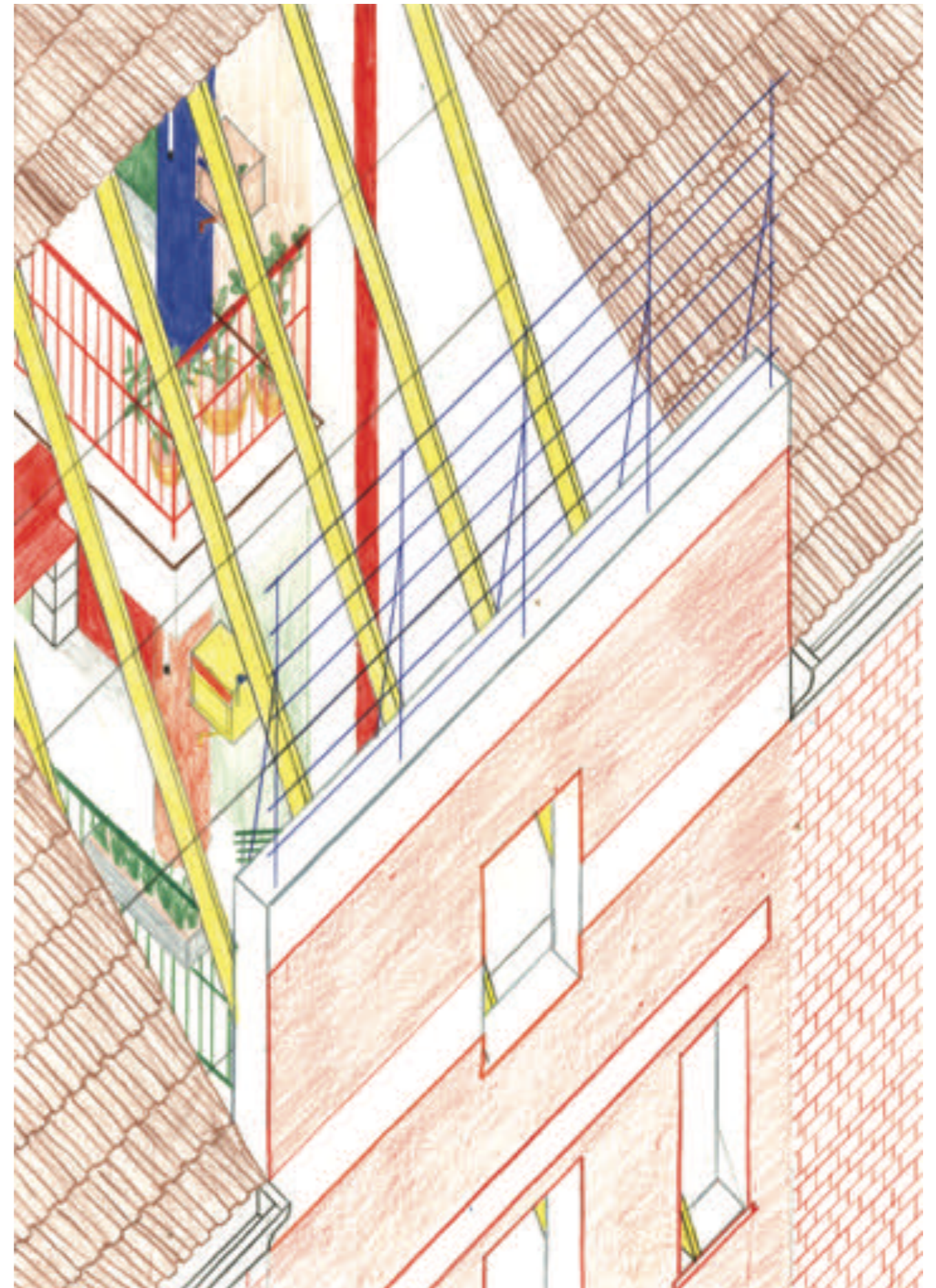
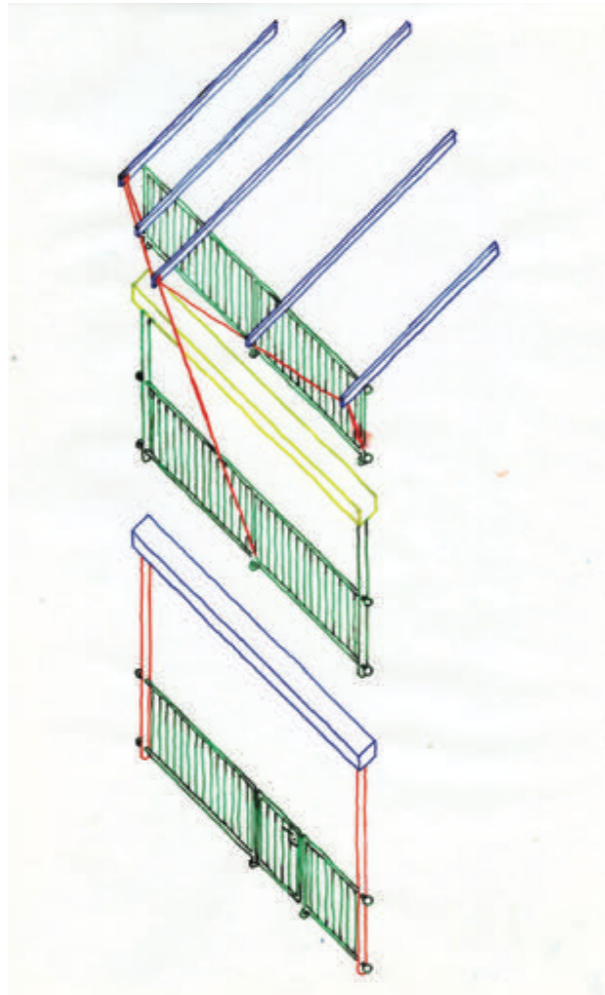

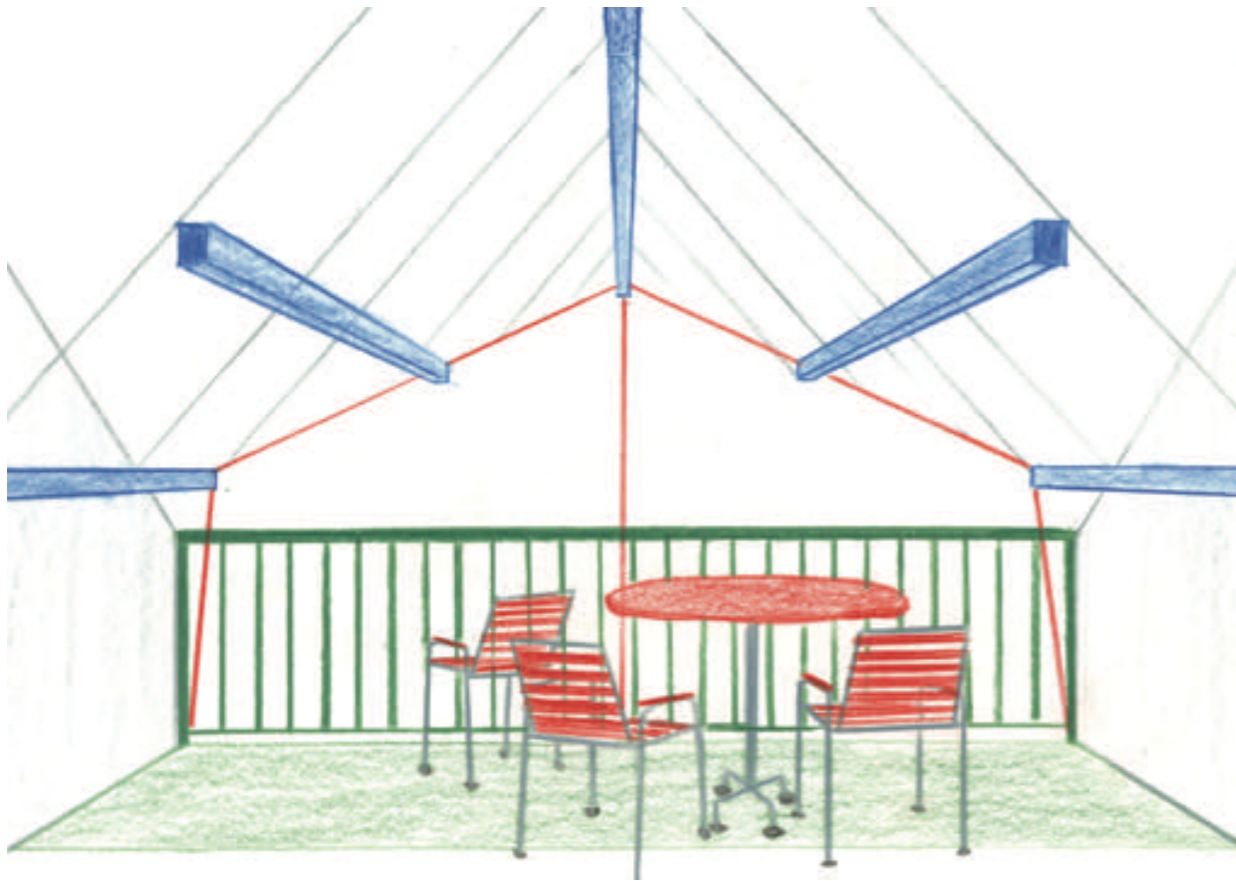



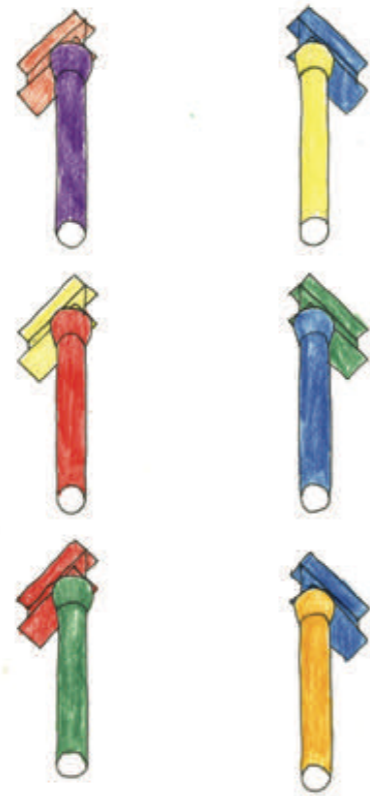



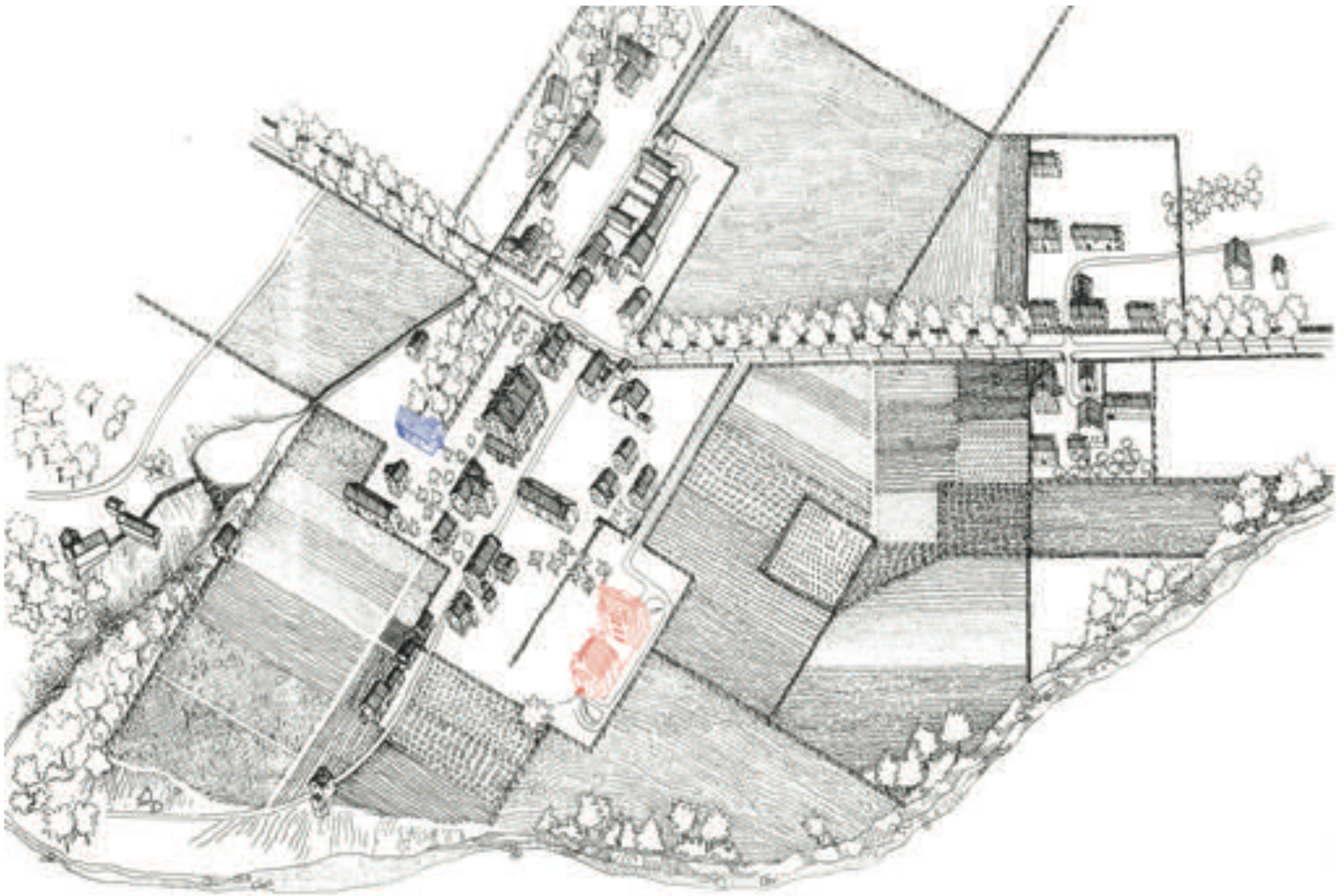

Apple's Conception of Sabbathday Lake, New Hampshire Shaker Village, Church and School Complex, 1780-1790. By Thomas Maxwell, Summer 1974.  
With the addition of R&H Schweitzer and Janis Stainhauser, Summer 2008.

# Movement 2

## BE in US





## Scattered

I just came home from doing the groceries, Lisbeth from next door has a lovely range of vegetables she grows herself. I kind of feel lively and sharp after this short stroll.

The floor of the entrance hall still spreads the smell of cleanser. Everthing in its right place. I have my two free hours now, no obligations, nothing to think of, isn't that nice? It sounds like I'm a busy woman, I know. Well, don't underestimate being a mother.

There's some dirt on the floor to our kitchen. Someone didn't manage to put his shoes off before getting inside. I'll do that afterwards. And Emelie forgot her lunch box - once again. How can they be so forgetful?

I just lost what I was thinking about before. And was it today or tomorrow that Finn's teacher called us in for a talk? Oskar meows like he wants something to eat, too. So many duties.

I teach my kids that imperfection isn't necessarily a negative thing, everyone needs a bit of looseness sometimes. Otherwise we'll become fanatics of everything, that can't be healthy. Our home definitely has space for that.

The oven alerts. I hit the thick brick column with my feet while running back to the kitchen, why does it exactly need to stand there? A hurting ankle and a burnt cake, how nice.

Arthur just called me and asked If I could look for his wallet in our bedroom, of course I can sweetheart. At least I'm not the only chaotic person in this house. I'm still feeling confused, my head is full of things and empty at the same time, how did I get there?

I take a deep breath and treat myself with a freshly squeezed lime juice lemonade and let myself fall into the chair on our deck. At least at home it's allowed to be a bit scattered.







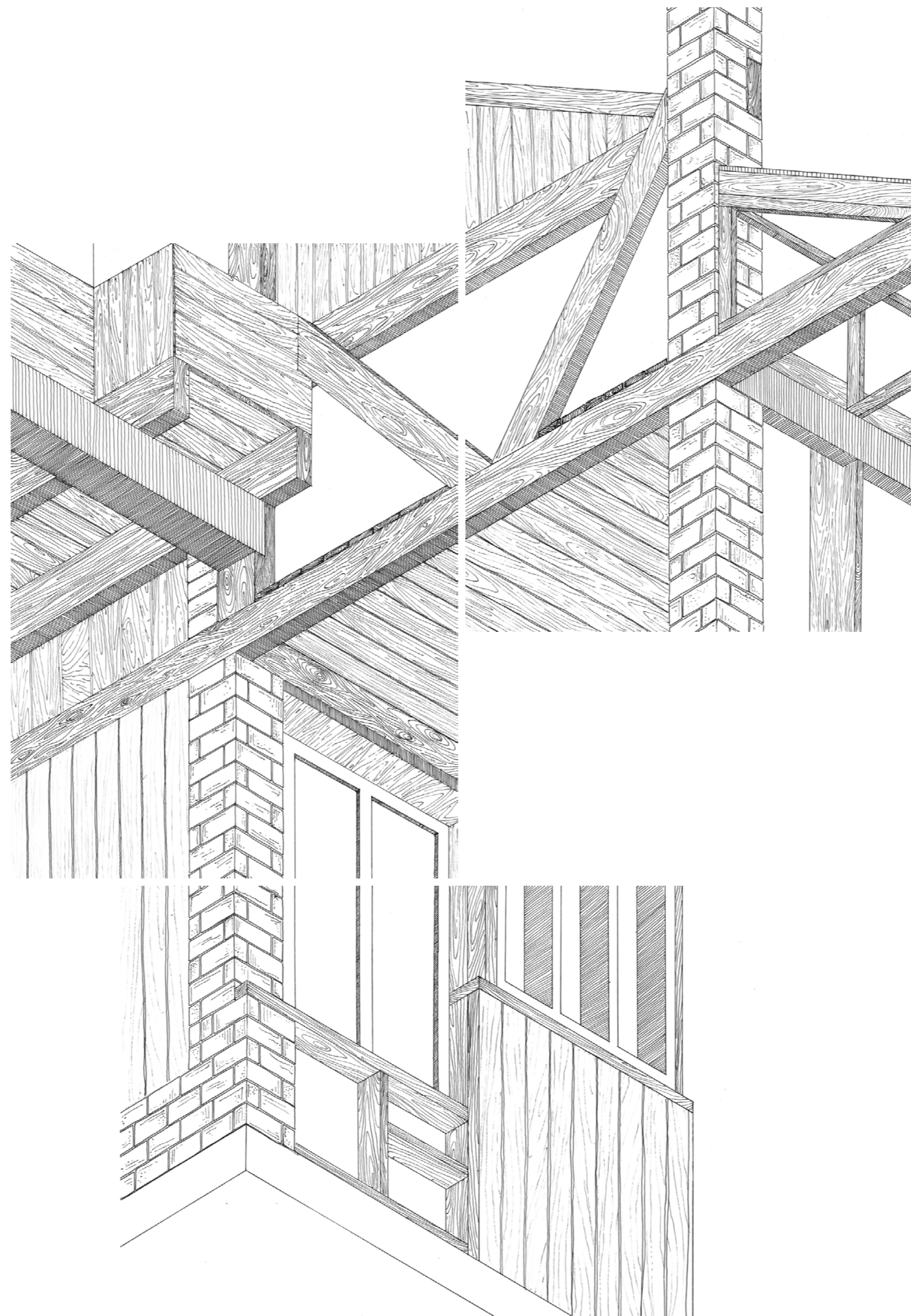



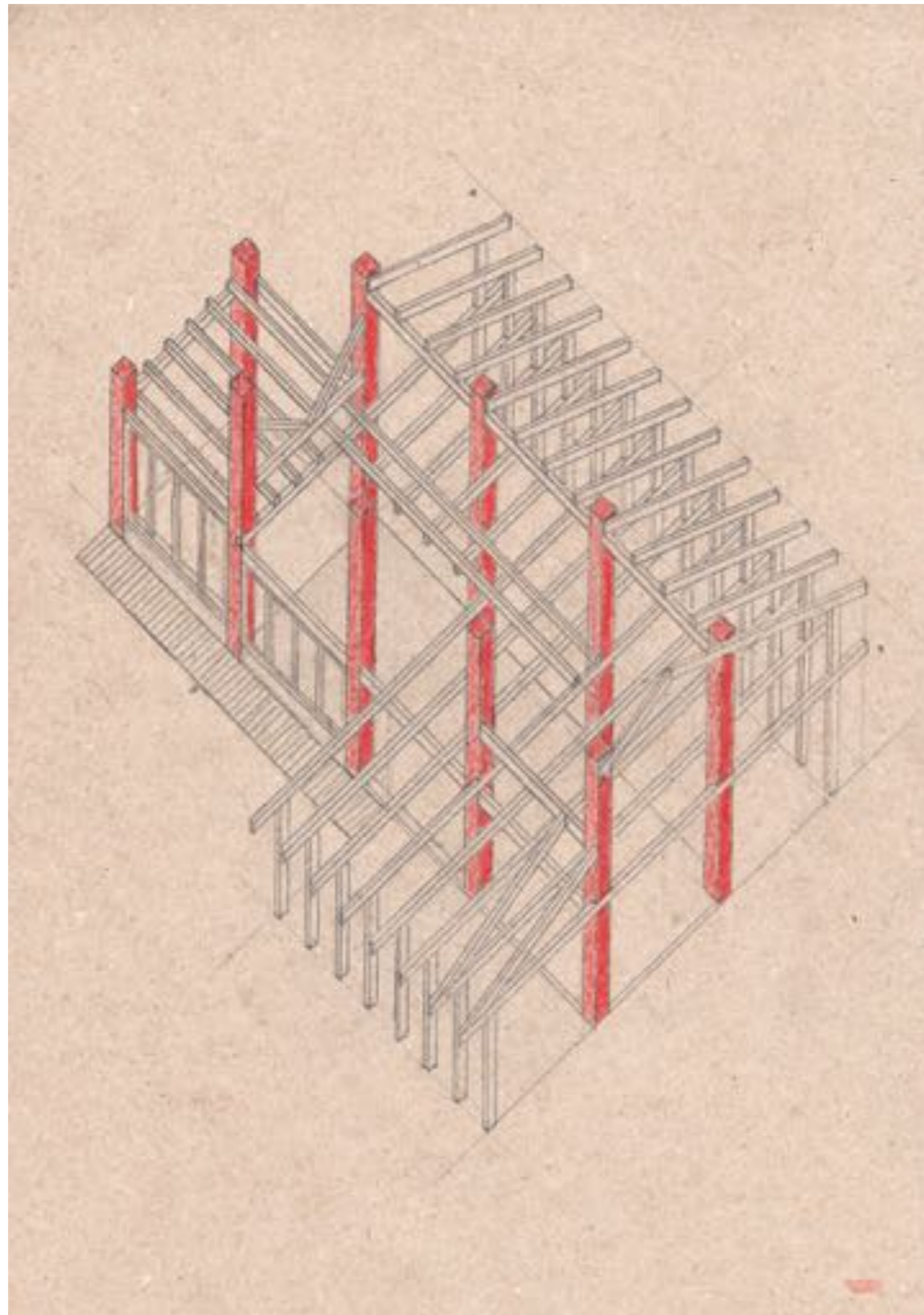

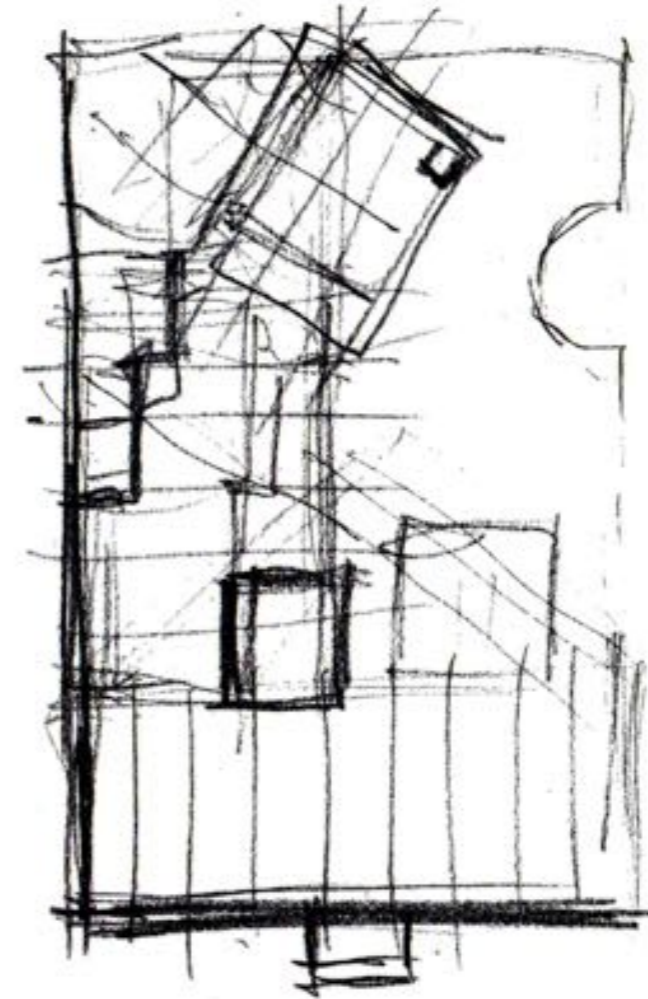

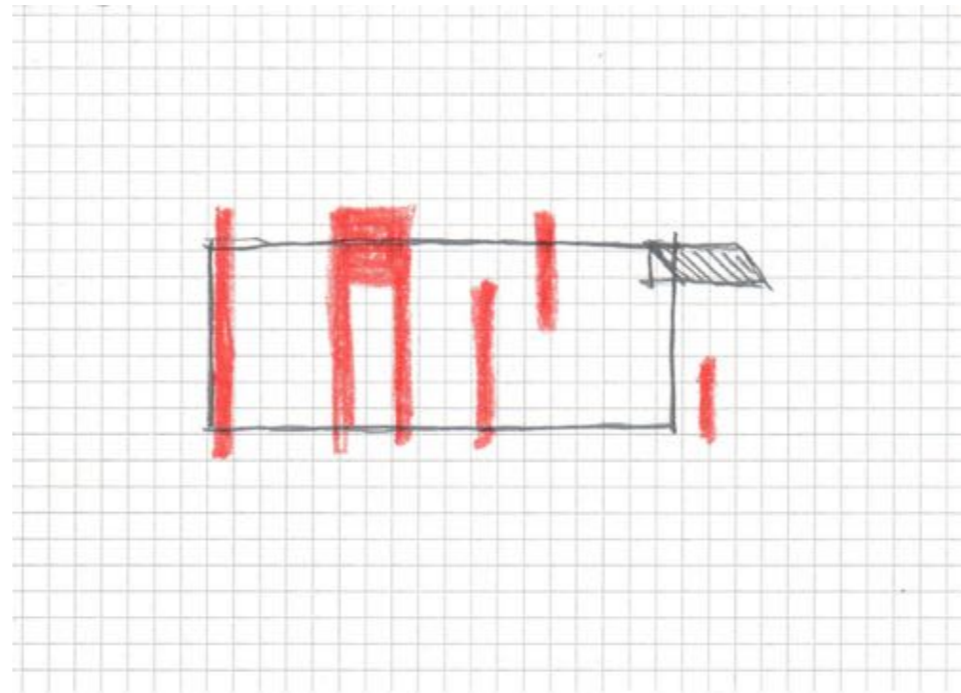



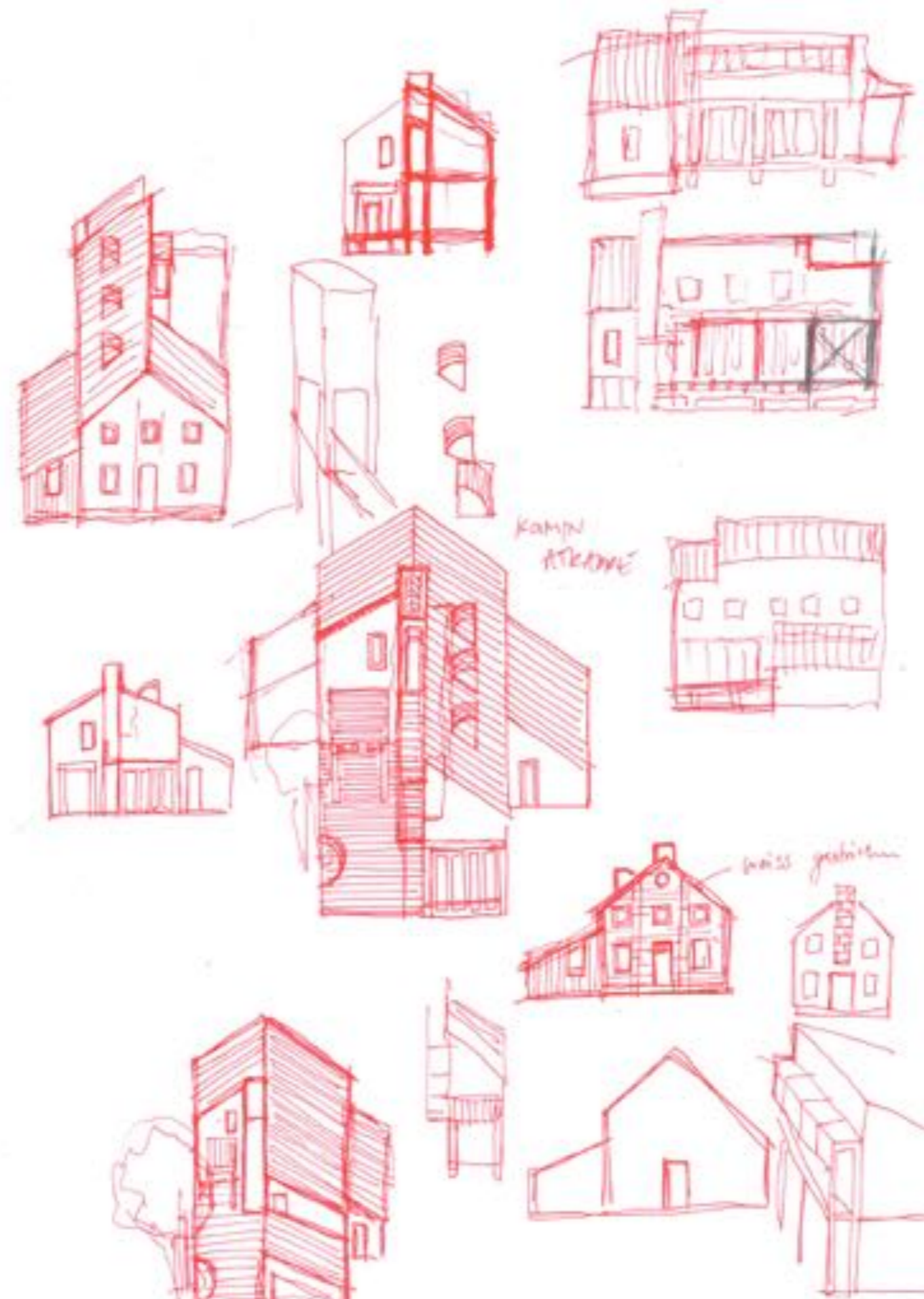





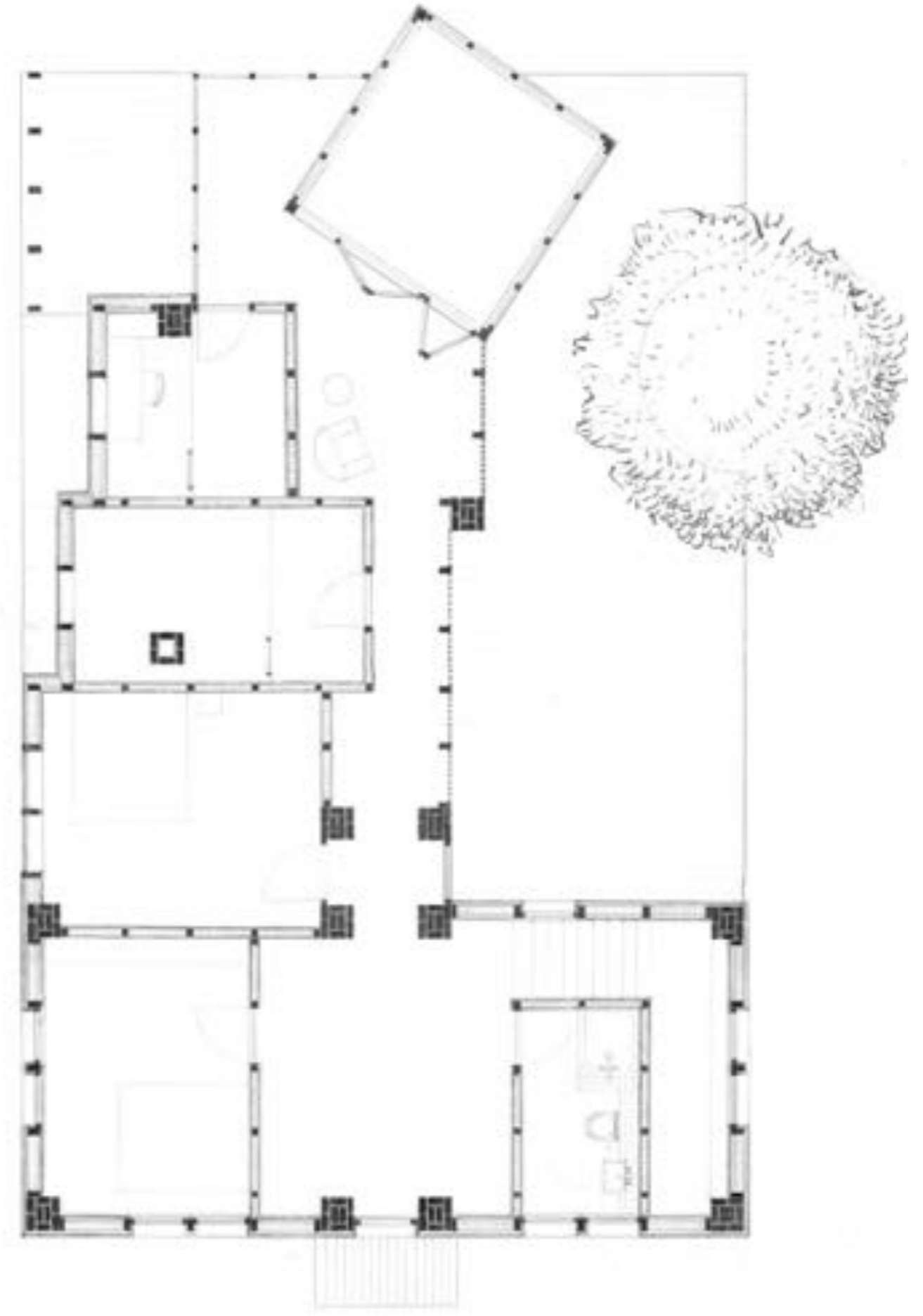
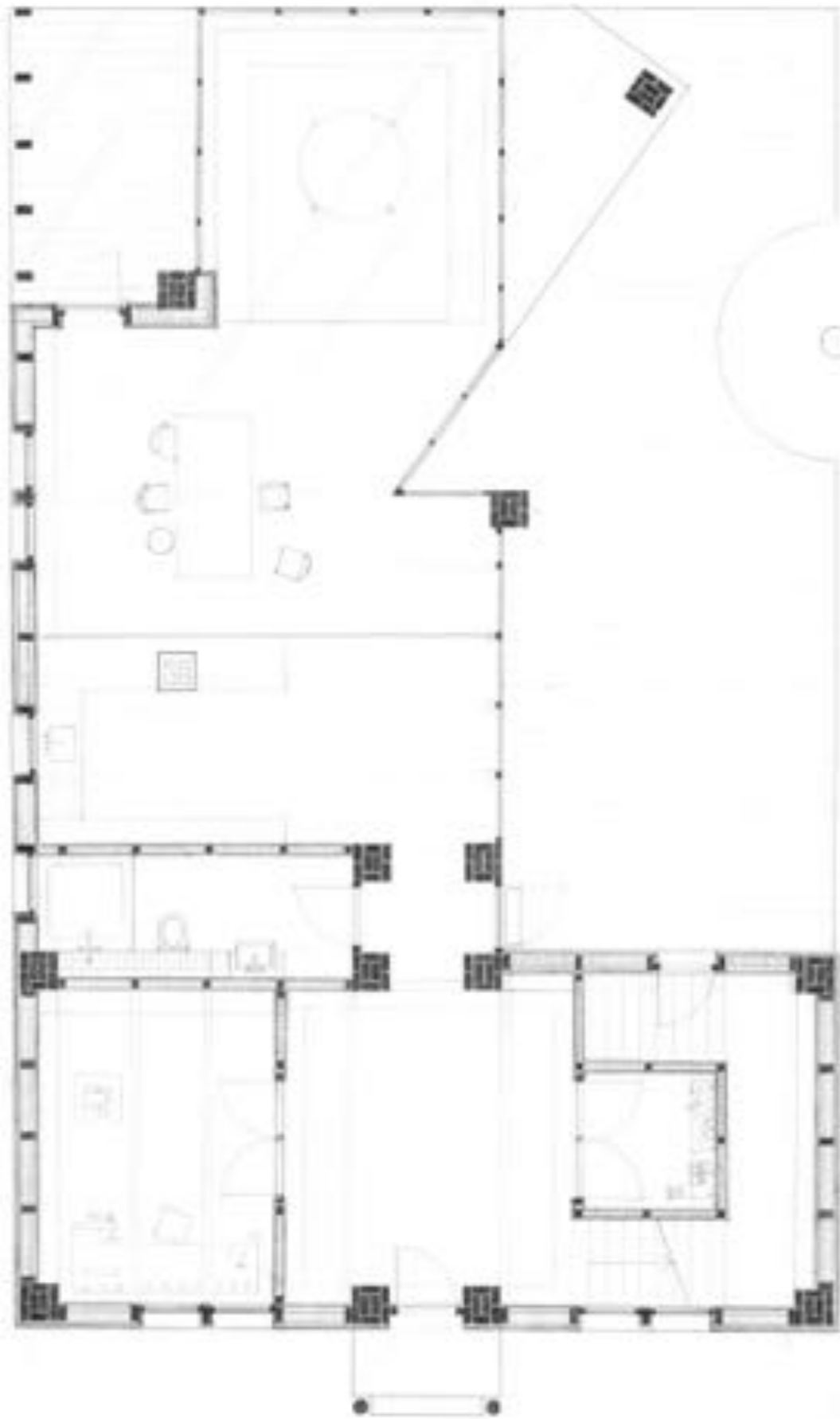

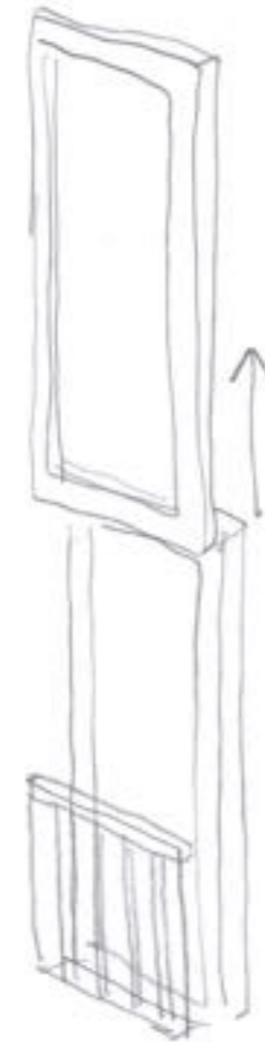

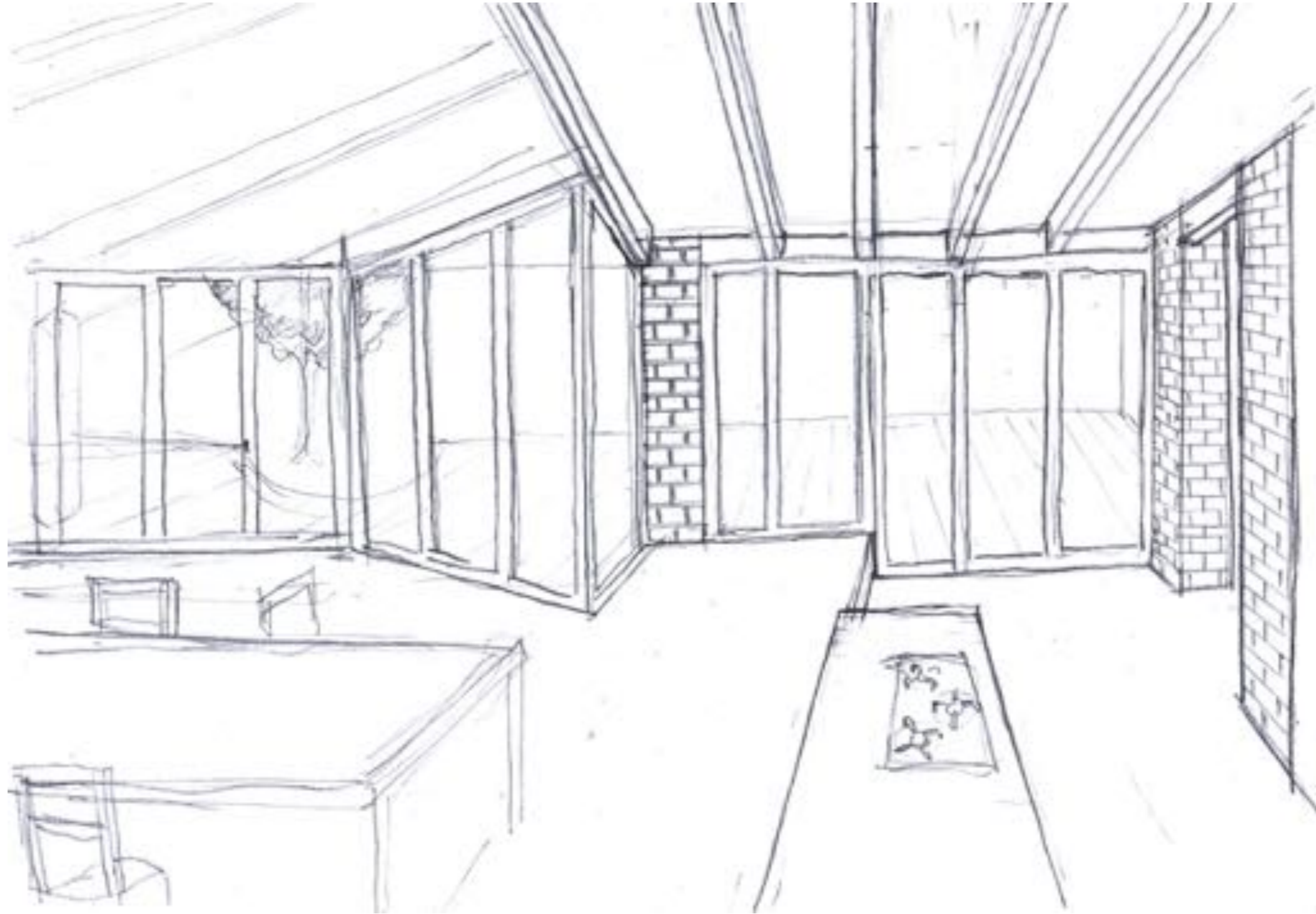

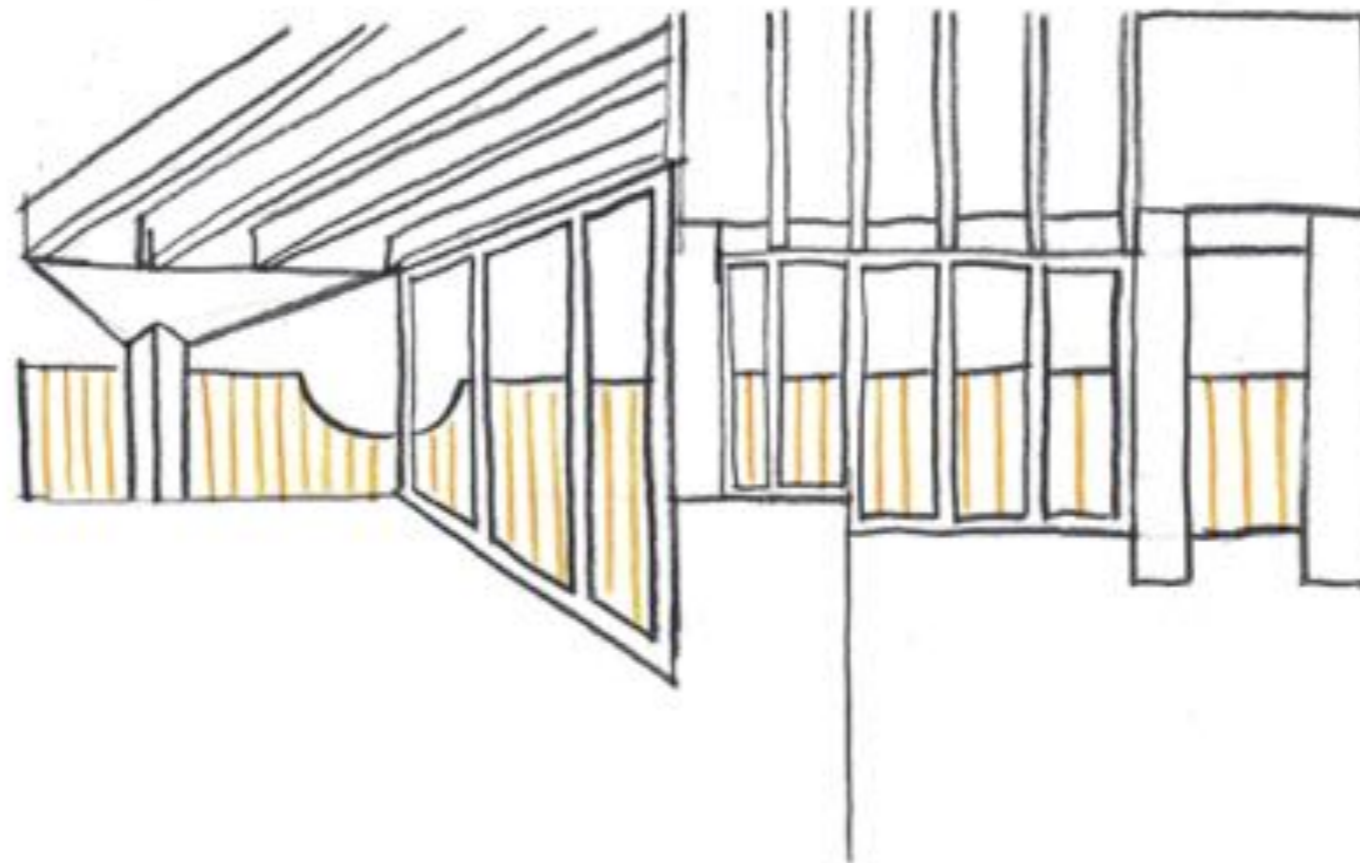





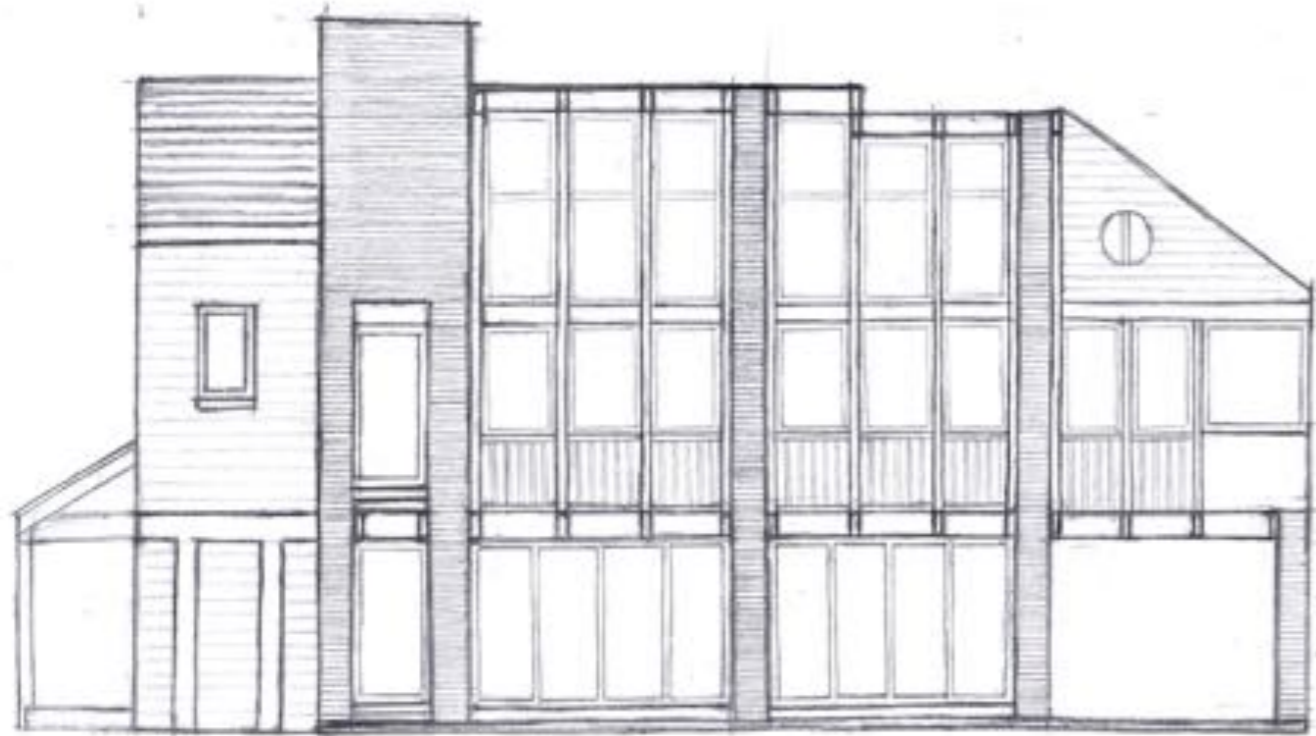





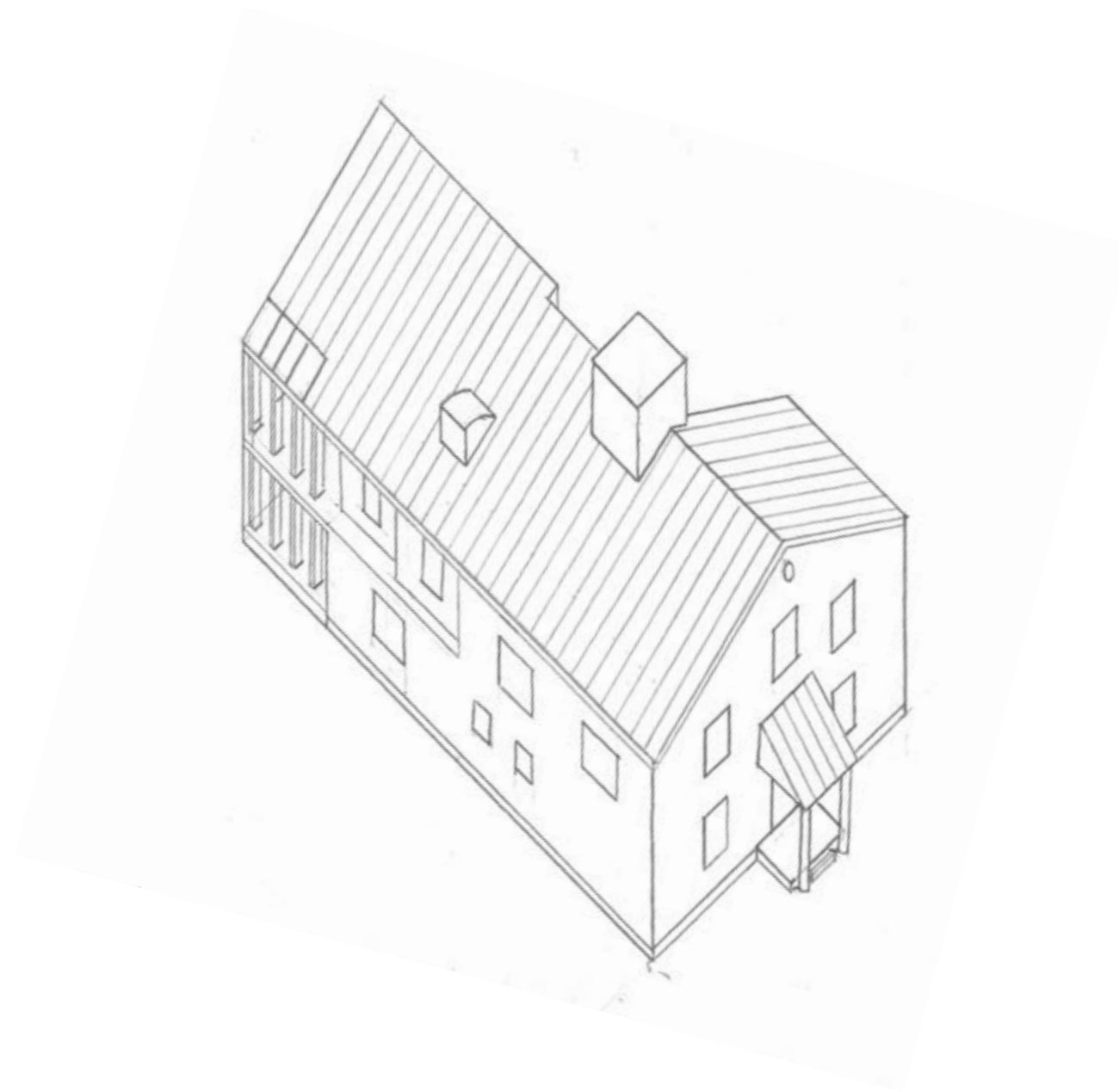

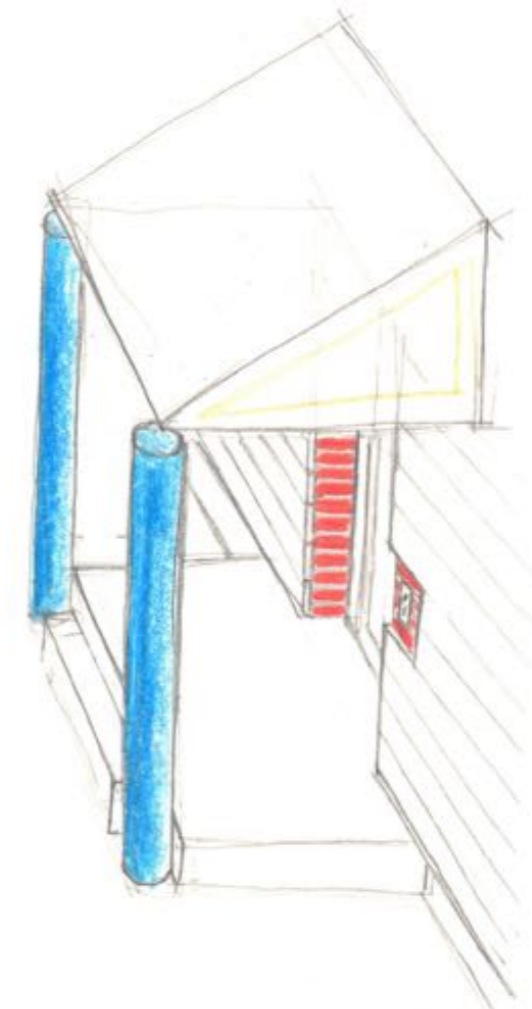
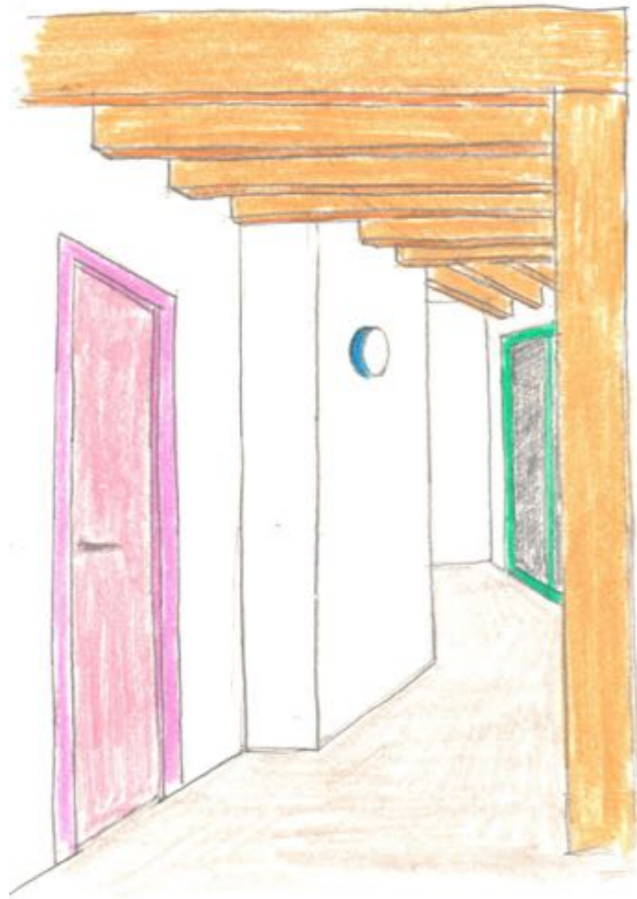



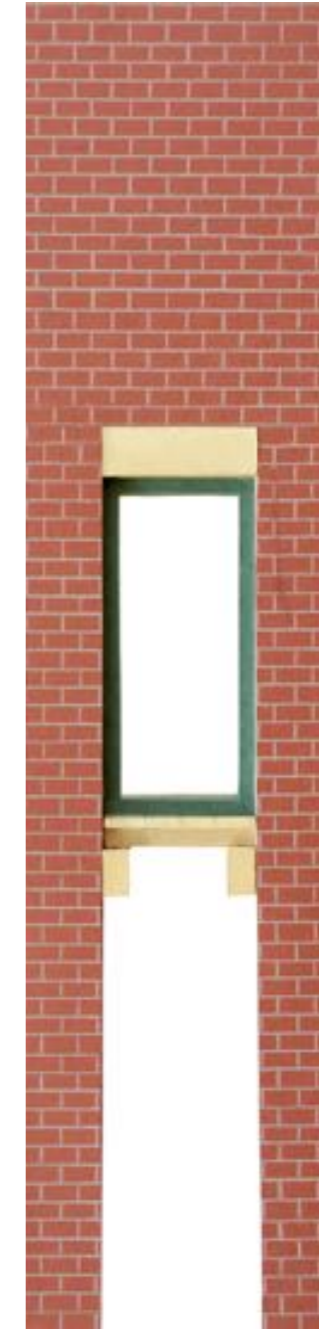
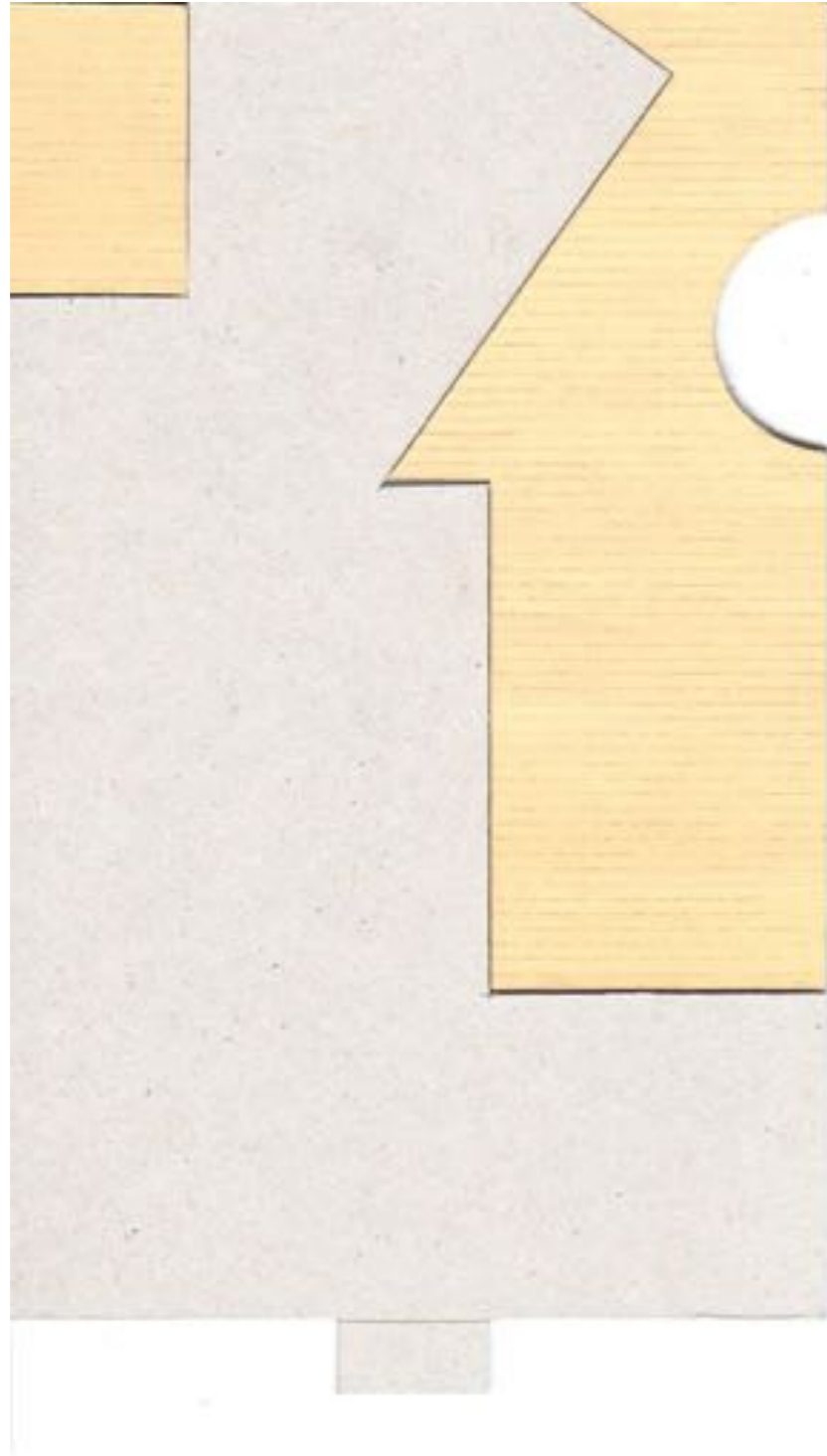

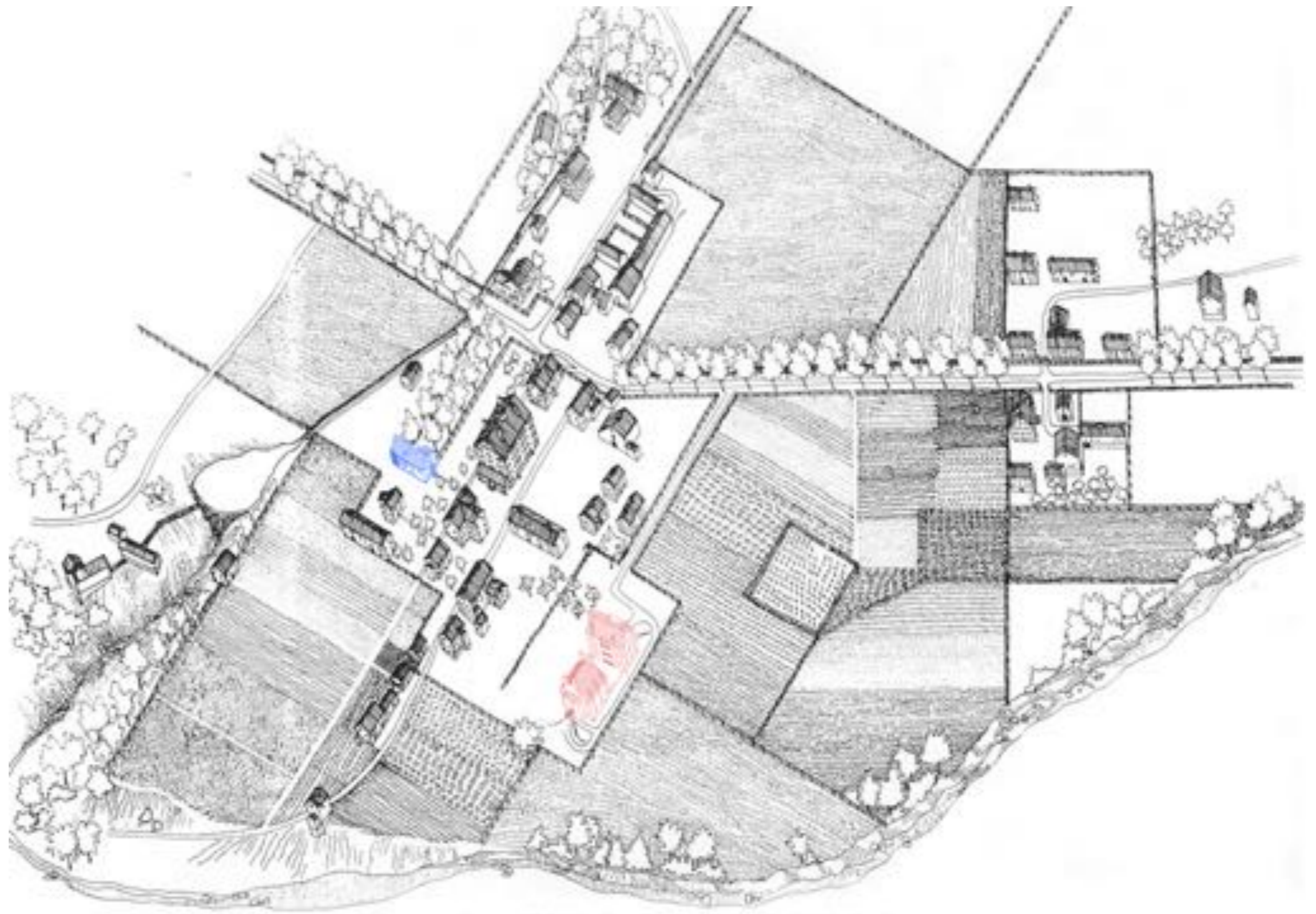

Arthur's Conception of Enfield, New Hampshire Shaker Village, Church and North Families, circa 1800 - 1800. By Phyllis Maynard, Summer 1978.  
With the addition of Ralf Schweizer and Janis Stainhauser, Summer 2020.



A

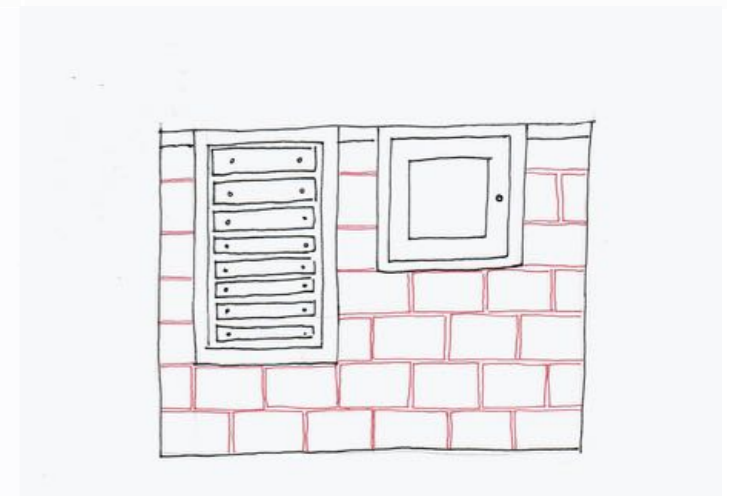
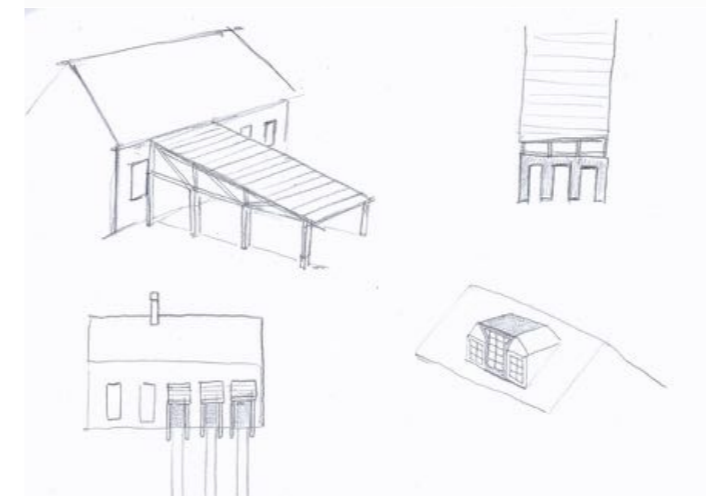
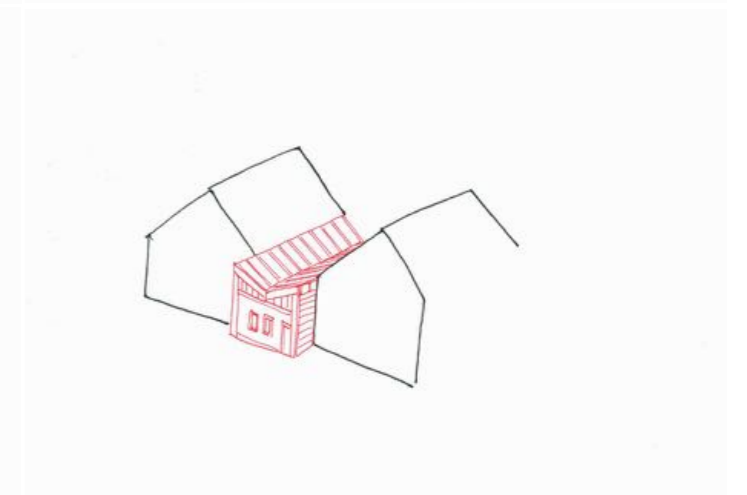
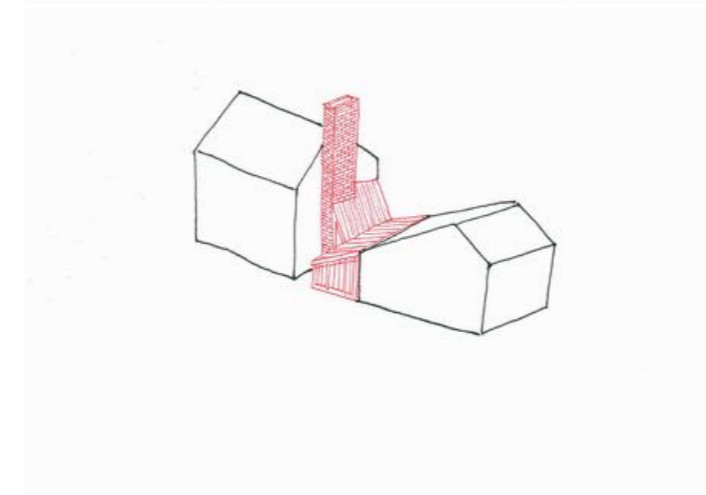
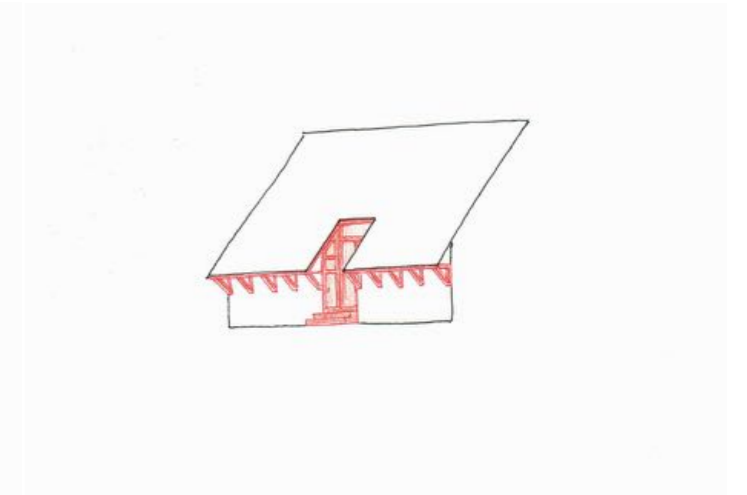
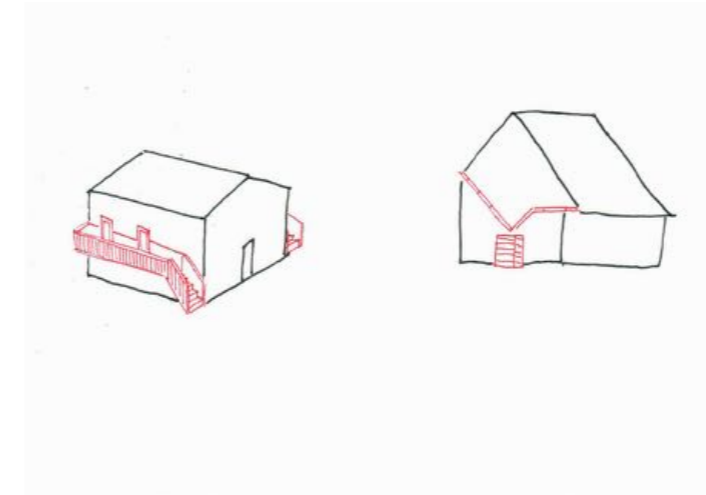
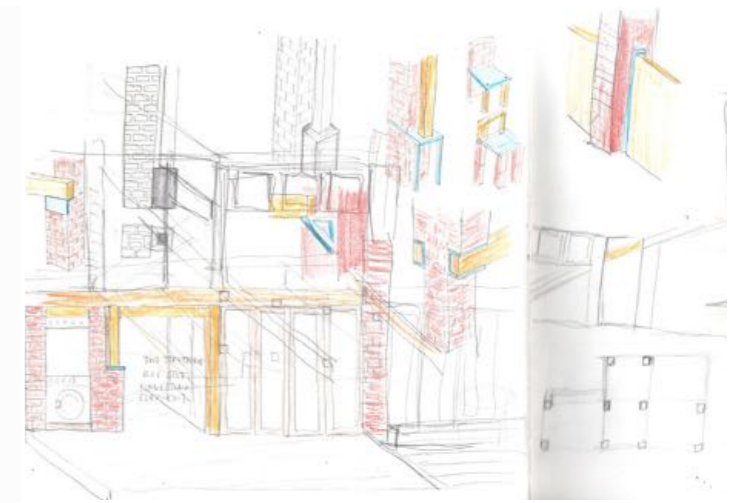
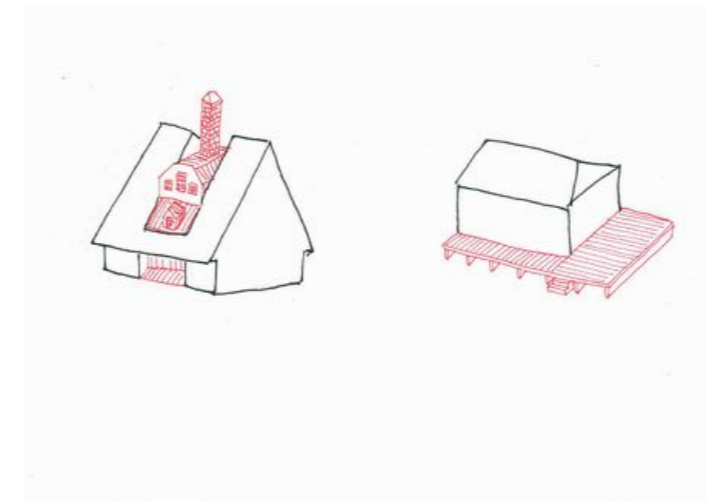
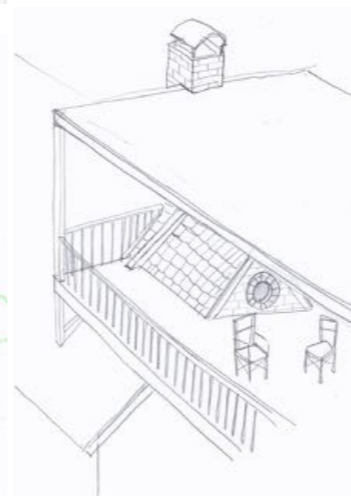
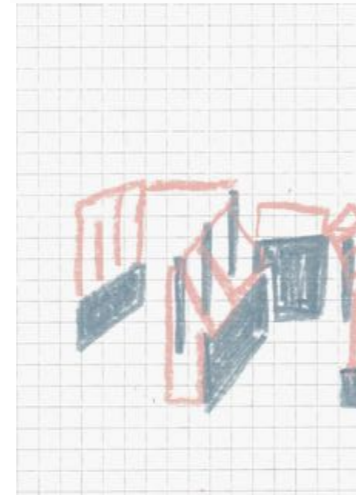
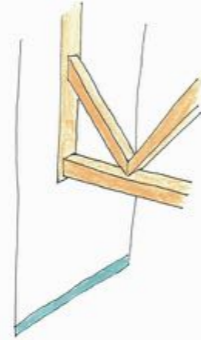
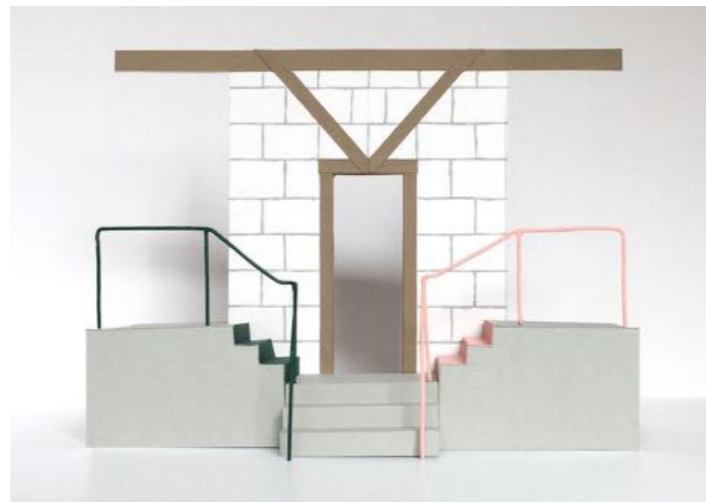

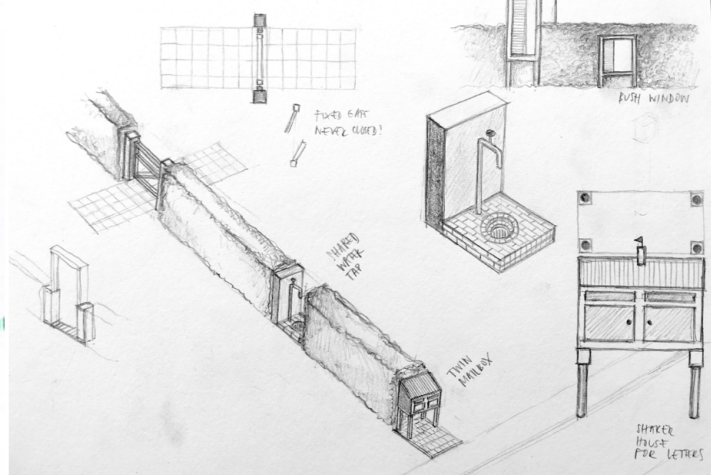
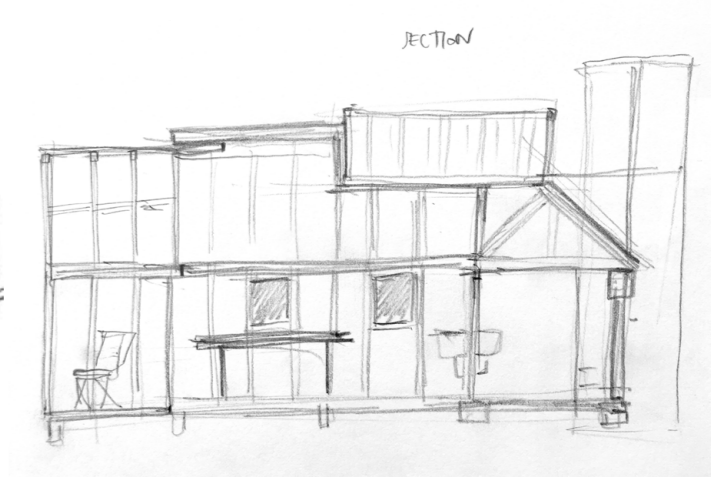
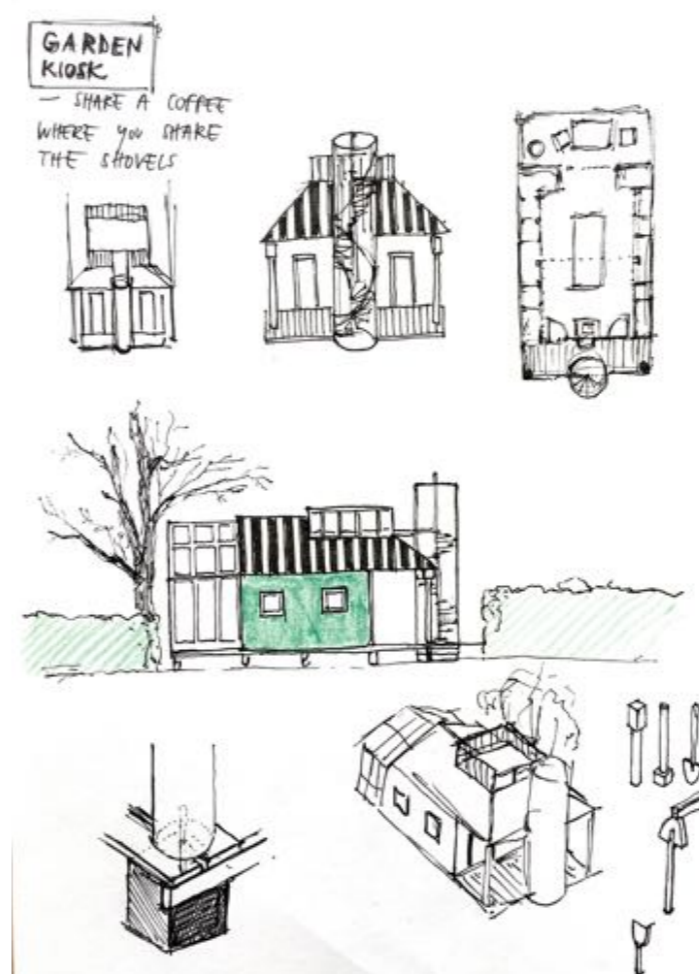
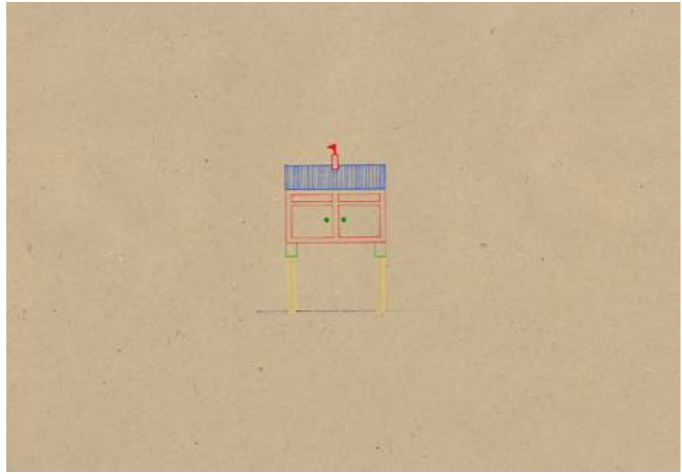
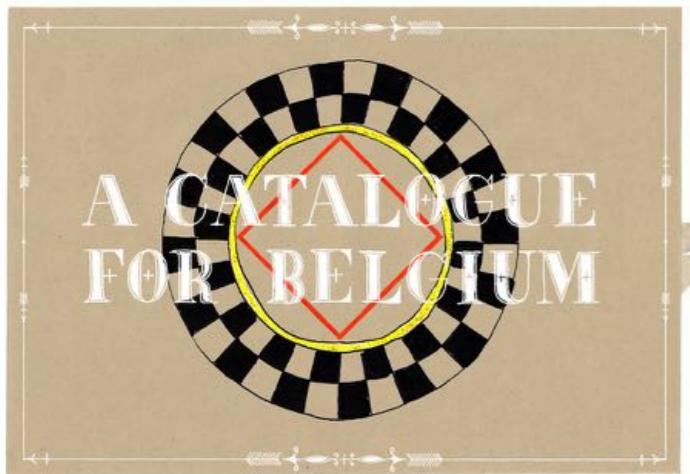
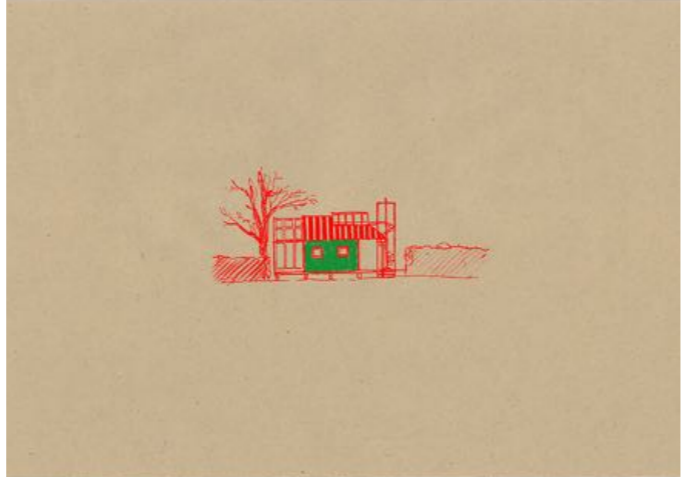
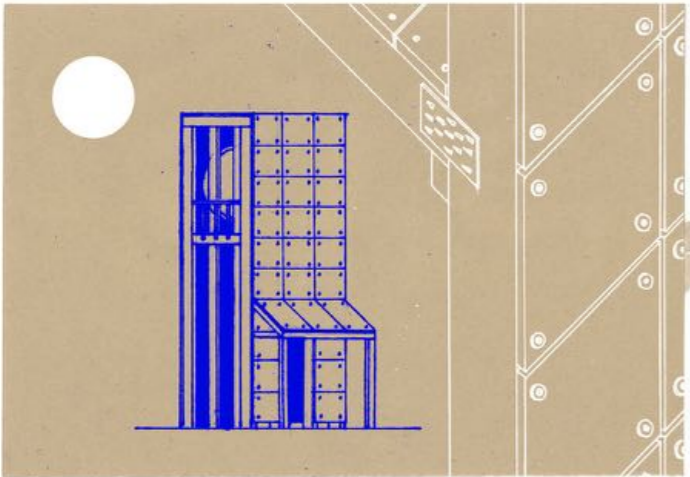
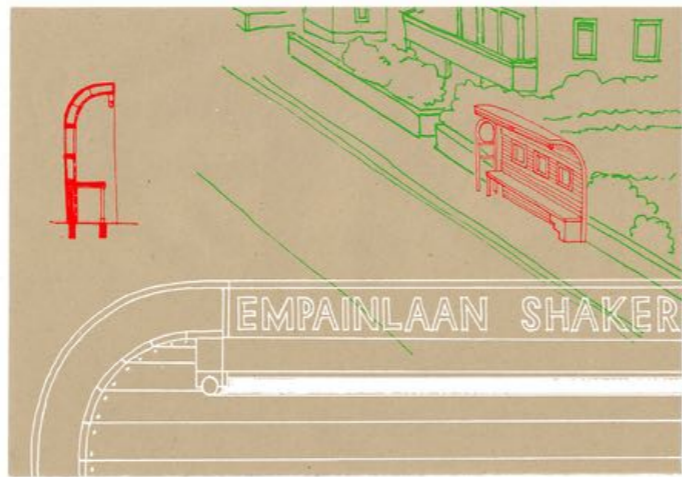
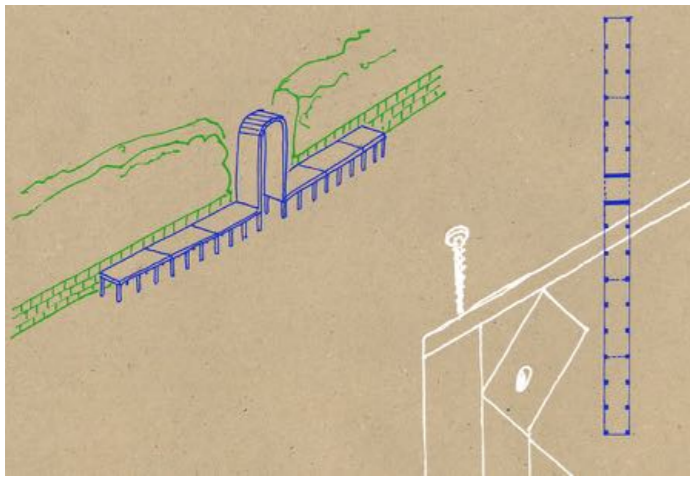

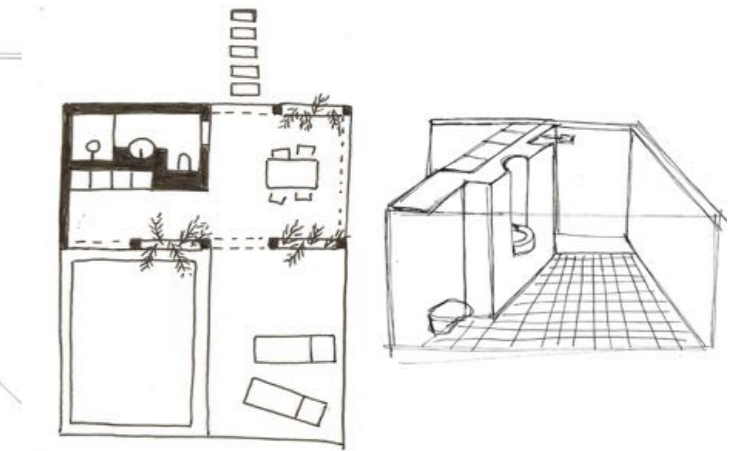
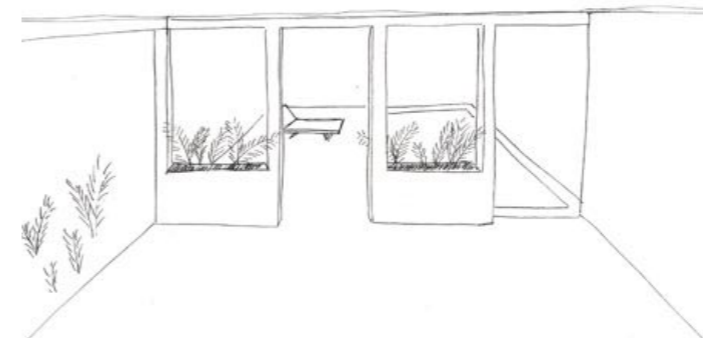
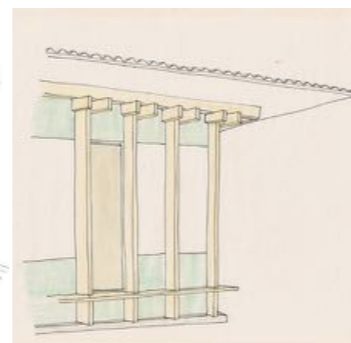
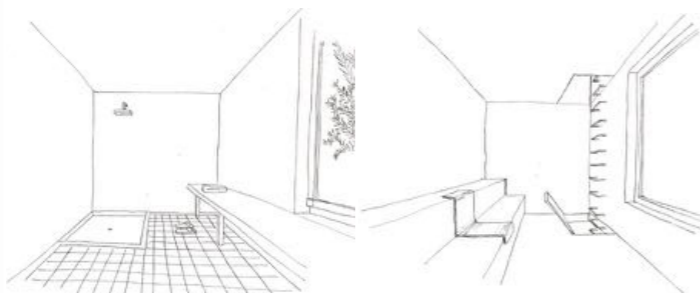
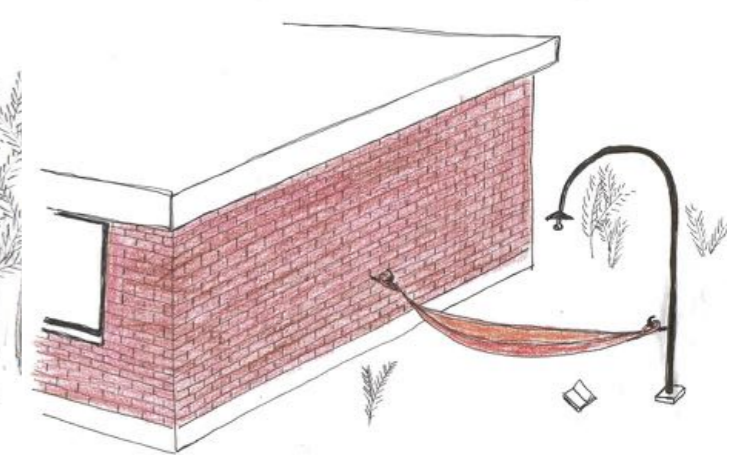
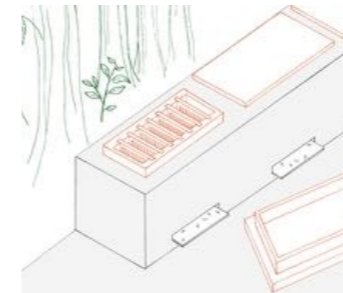
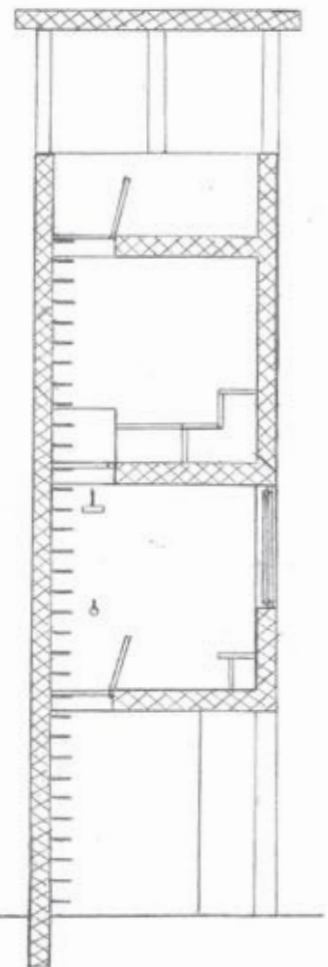
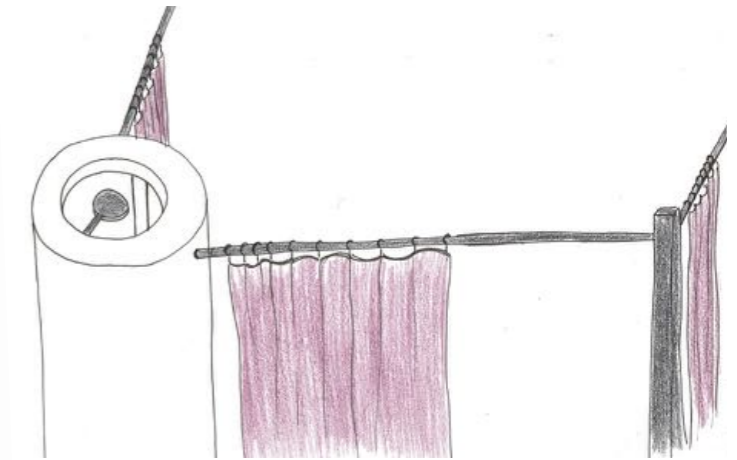
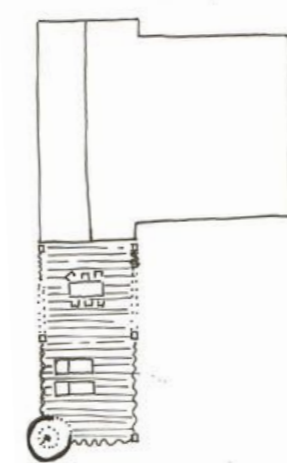
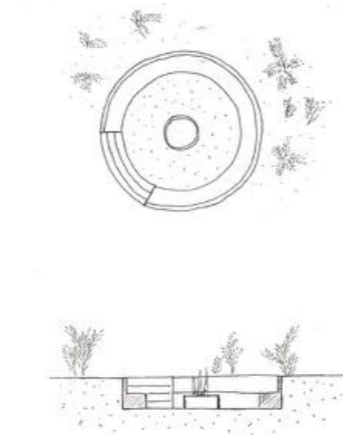
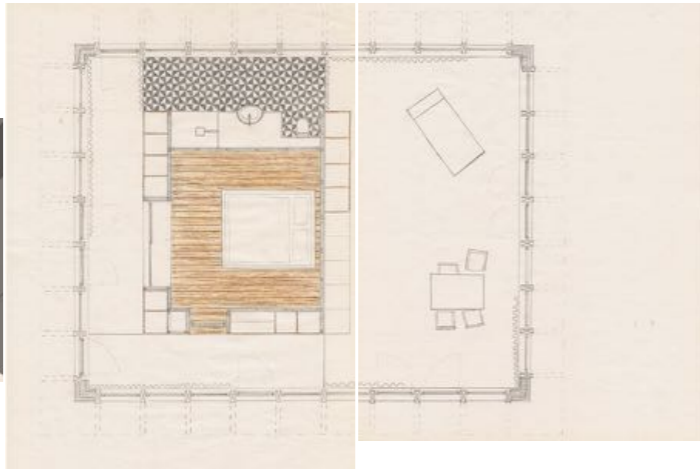
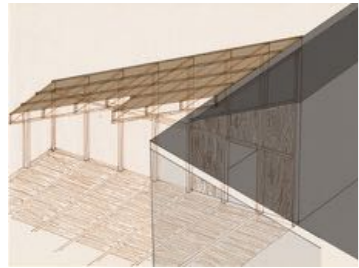
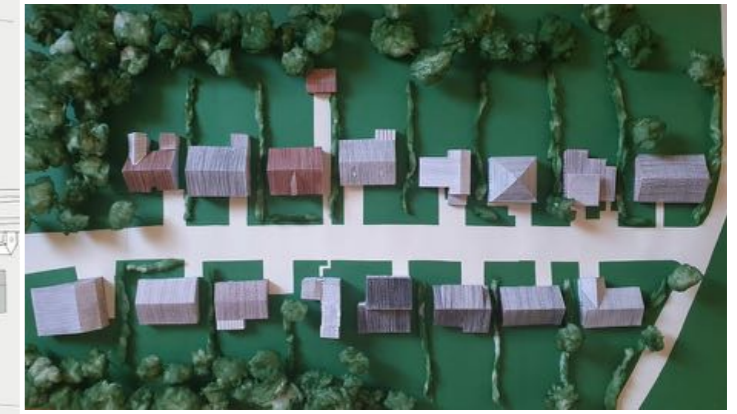

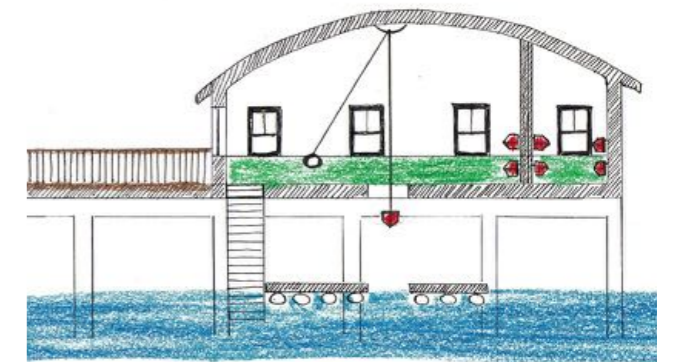
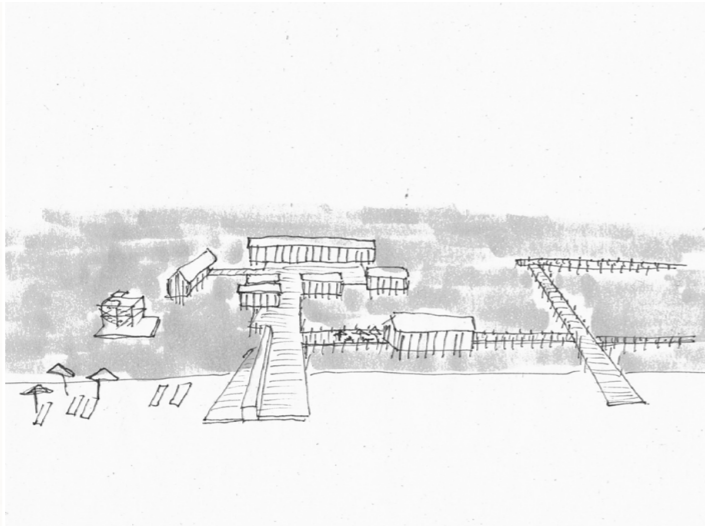
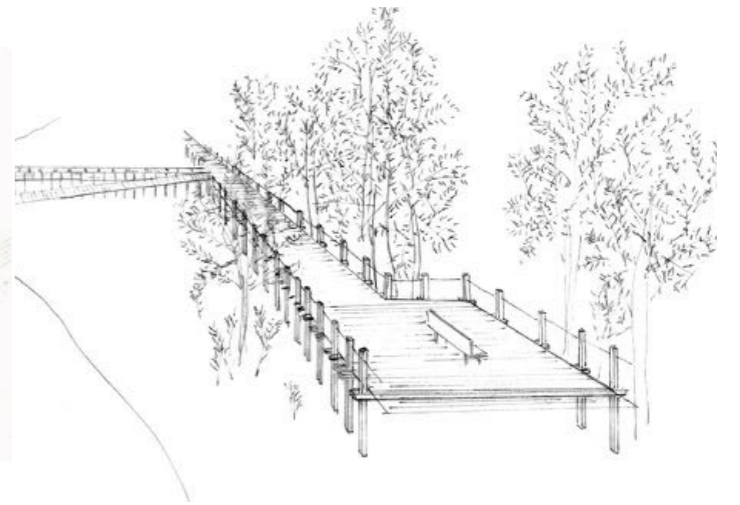
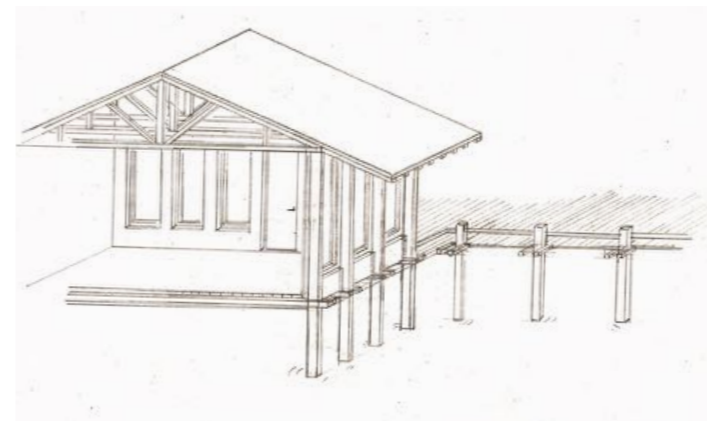
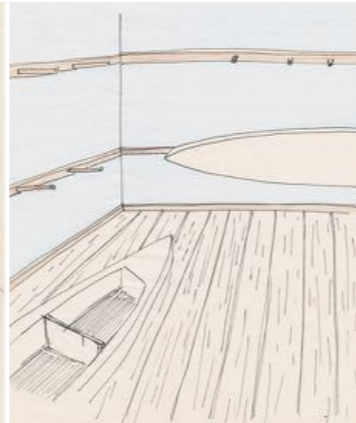
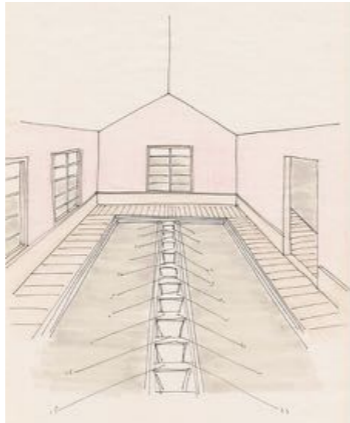
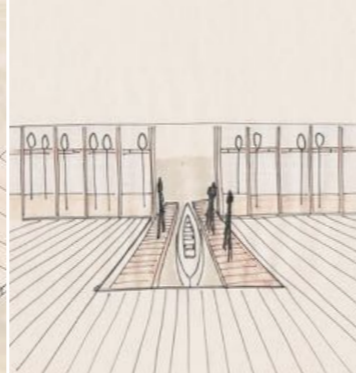
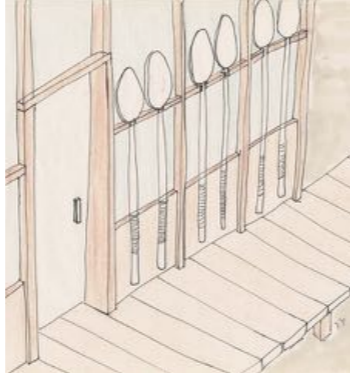
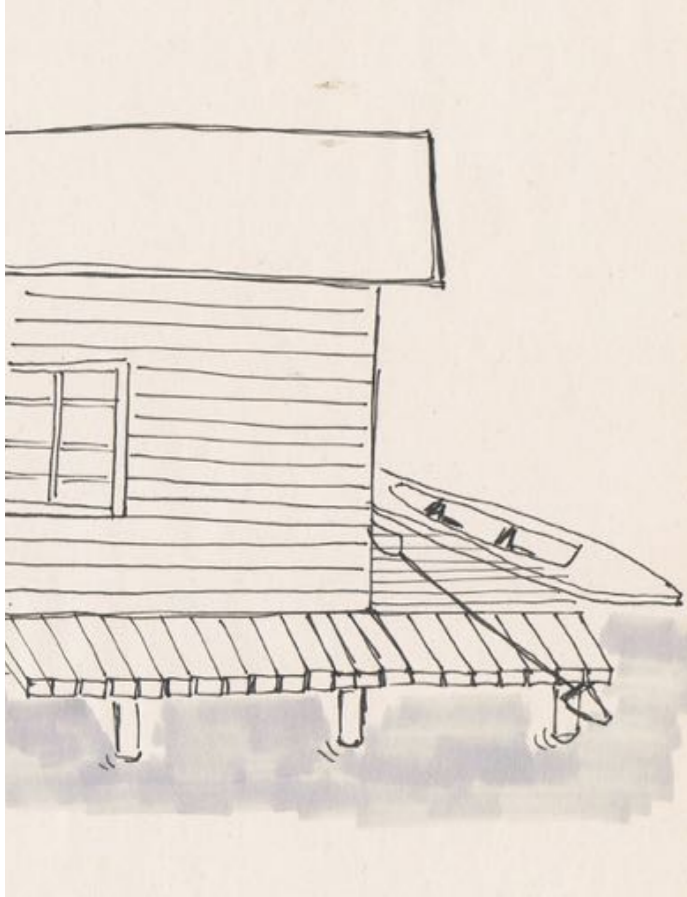
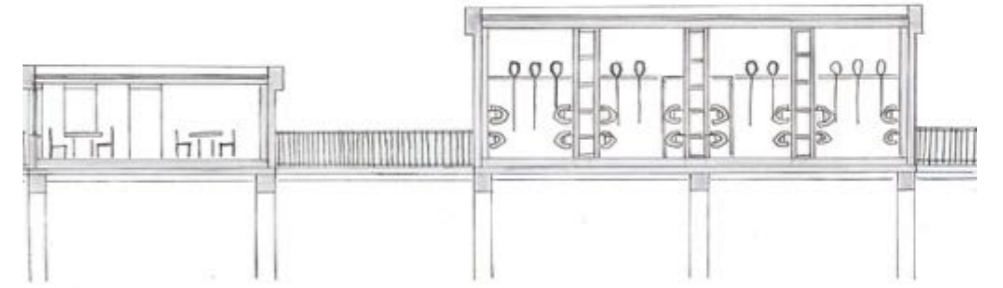
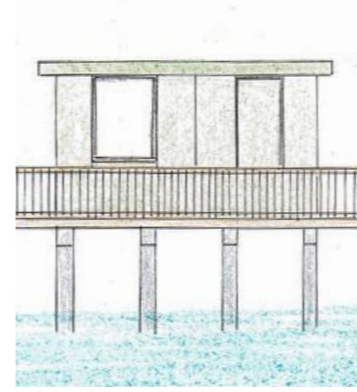
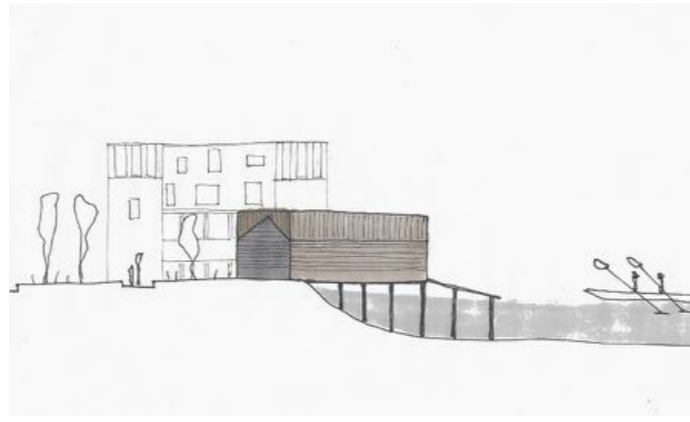

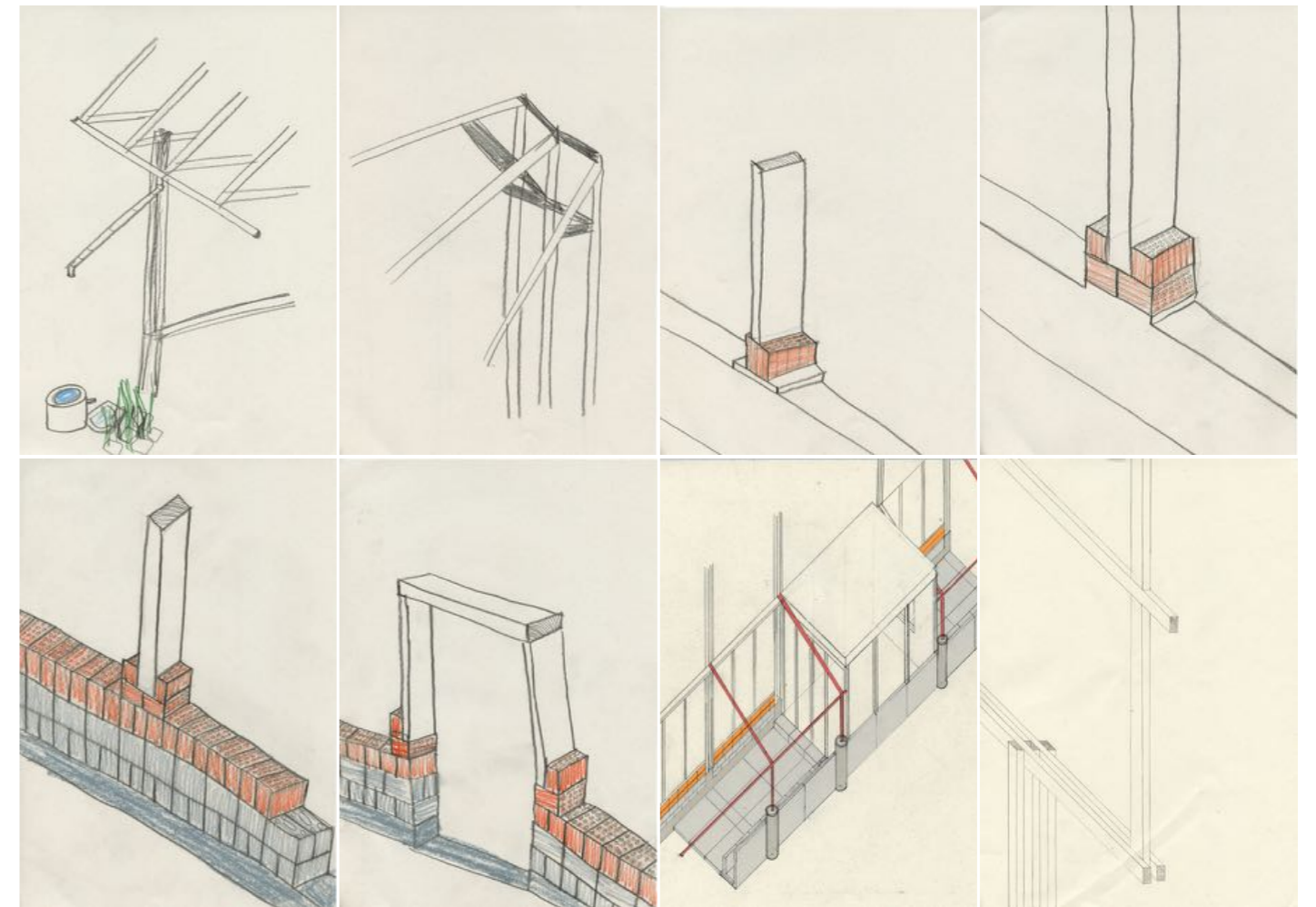
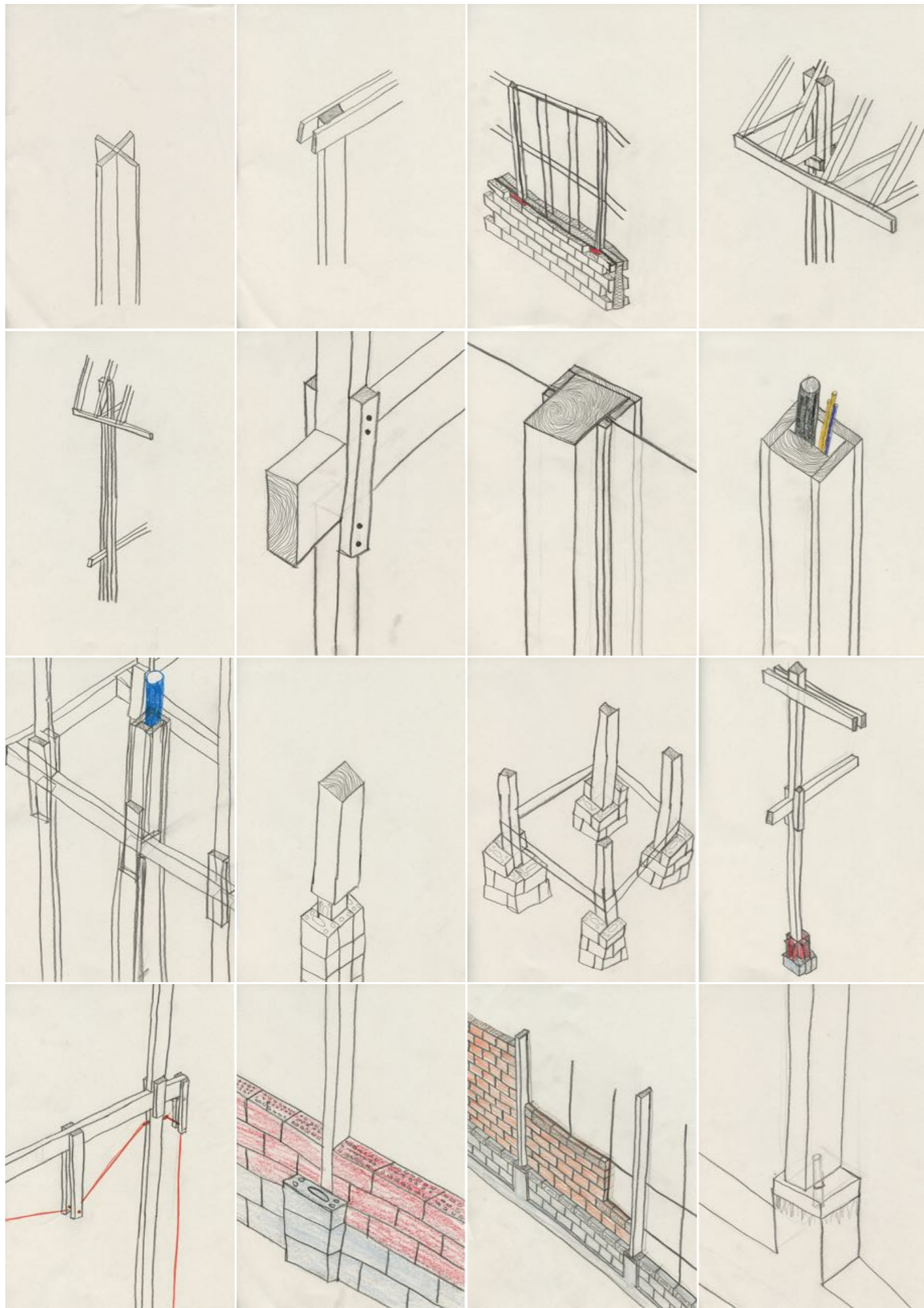

I have fond memories of my childhood. It was very nice growing up in this environment. Therefore I am very happy that I can offer to my children as well. At the same time I am also happy that my children do not have to grow up in the same house as me, because although my sister's family is much smaller, she now lives in the house.

We moved into our new home not far from her, in the small park of the original house, a few years ago. In many ways this house is different from my sister's, but I like it a lot. I think it is nice to listen to the bird singing in the morning. I even enjoy the concert in my house when it rains outside. I also like that I can feel different temperatures in my house depending on the weather.

And when we invite my sister and her family for dinner, they always come over with great joy.

