

universum carrousel journey  
re-practice prac-teach – a method  
making meandering meaning – the studio  
final review – spring 2020

**Henrike Heuer**

**Carmino Laurin Weber**

**Tobias vonder Mühl**

universum carrousel journey – a studio  
carrousel journey universum – a practice  
journey universum carrousel – whatever  
Studio Jan De Vylder  
ETH Zürich D-ARCH IEA – FS 2020

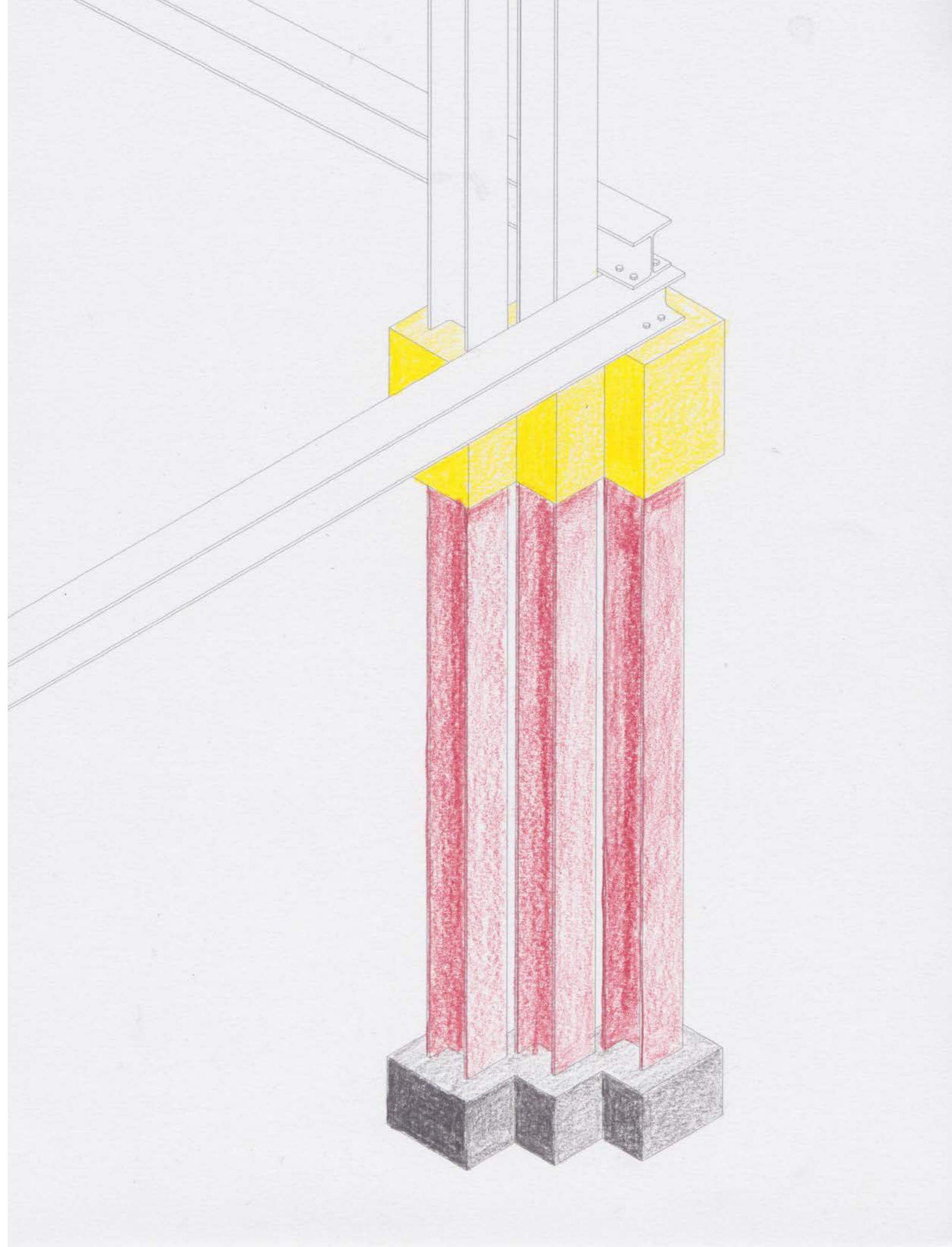

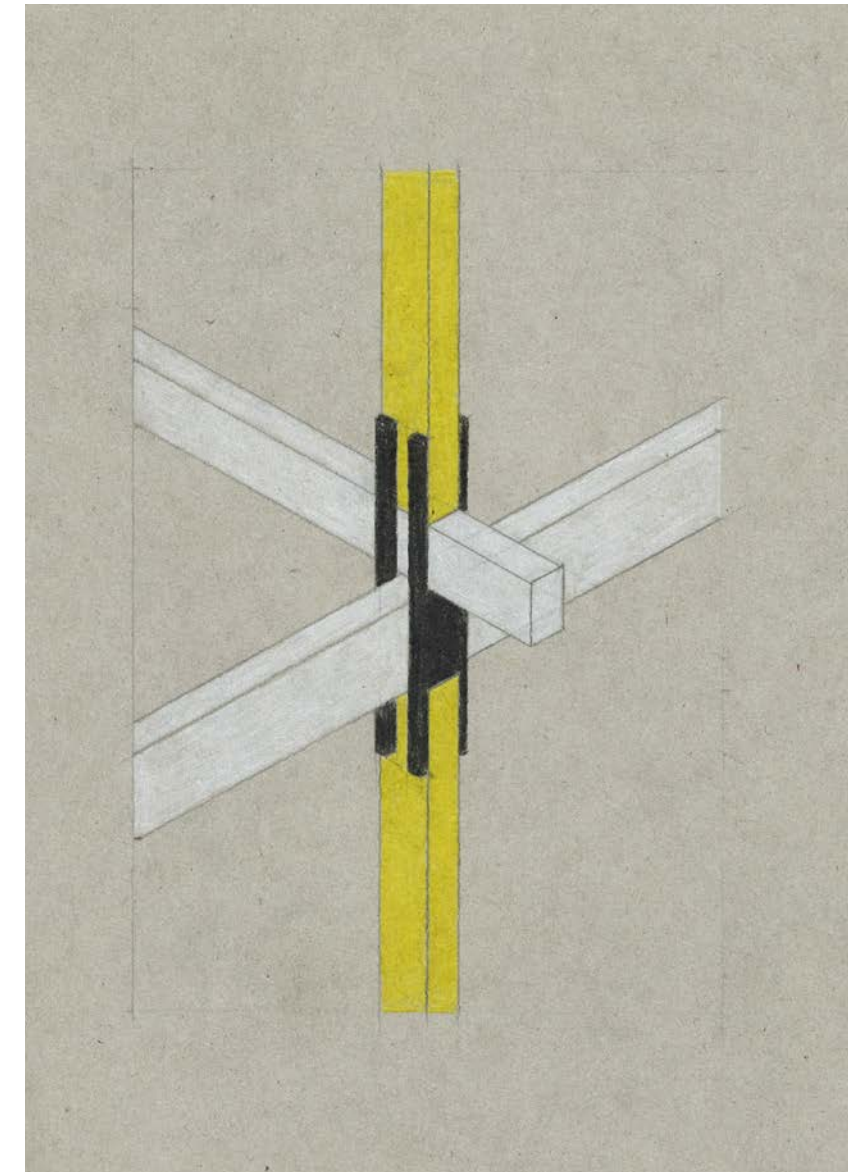
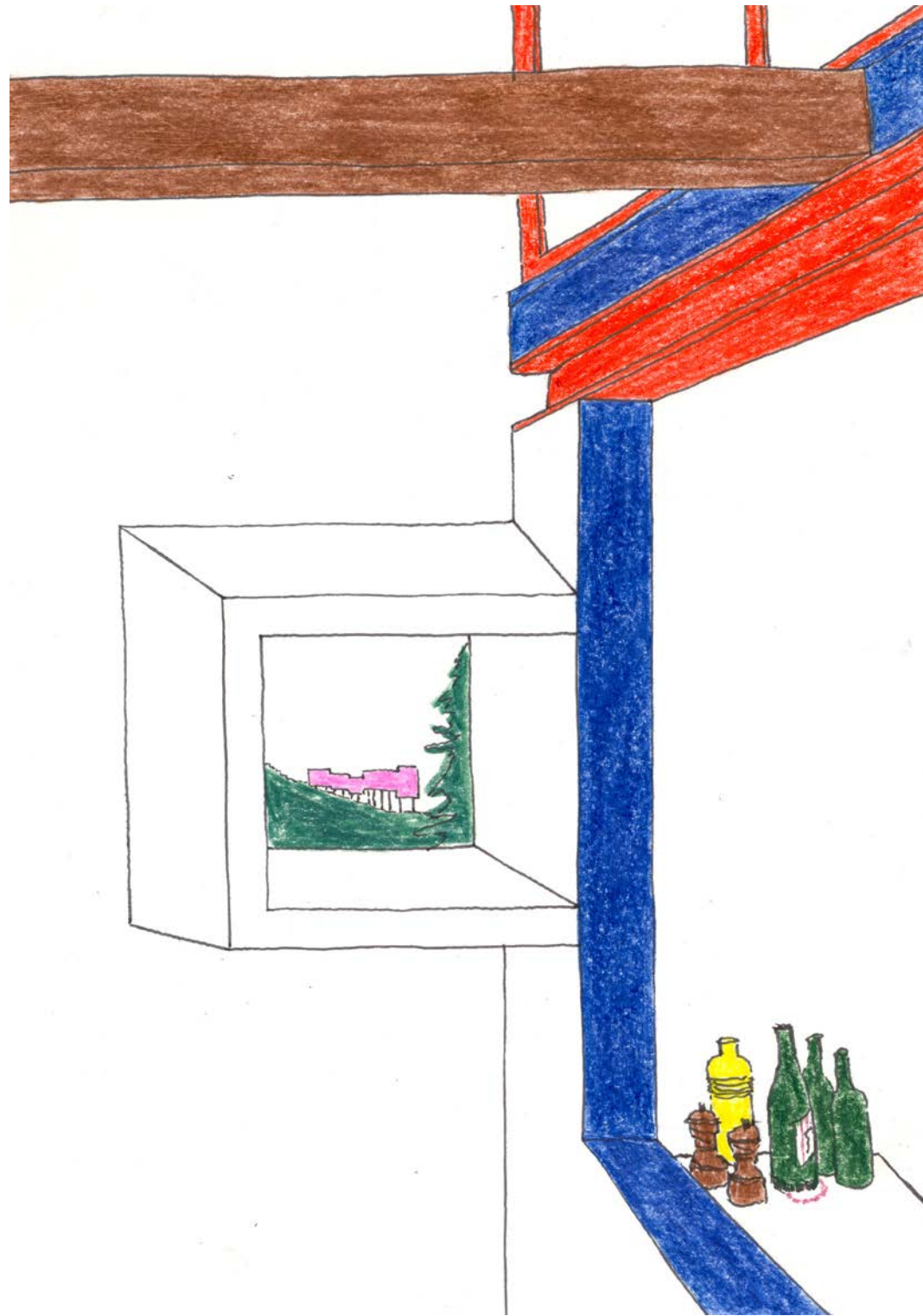

# Movement 1

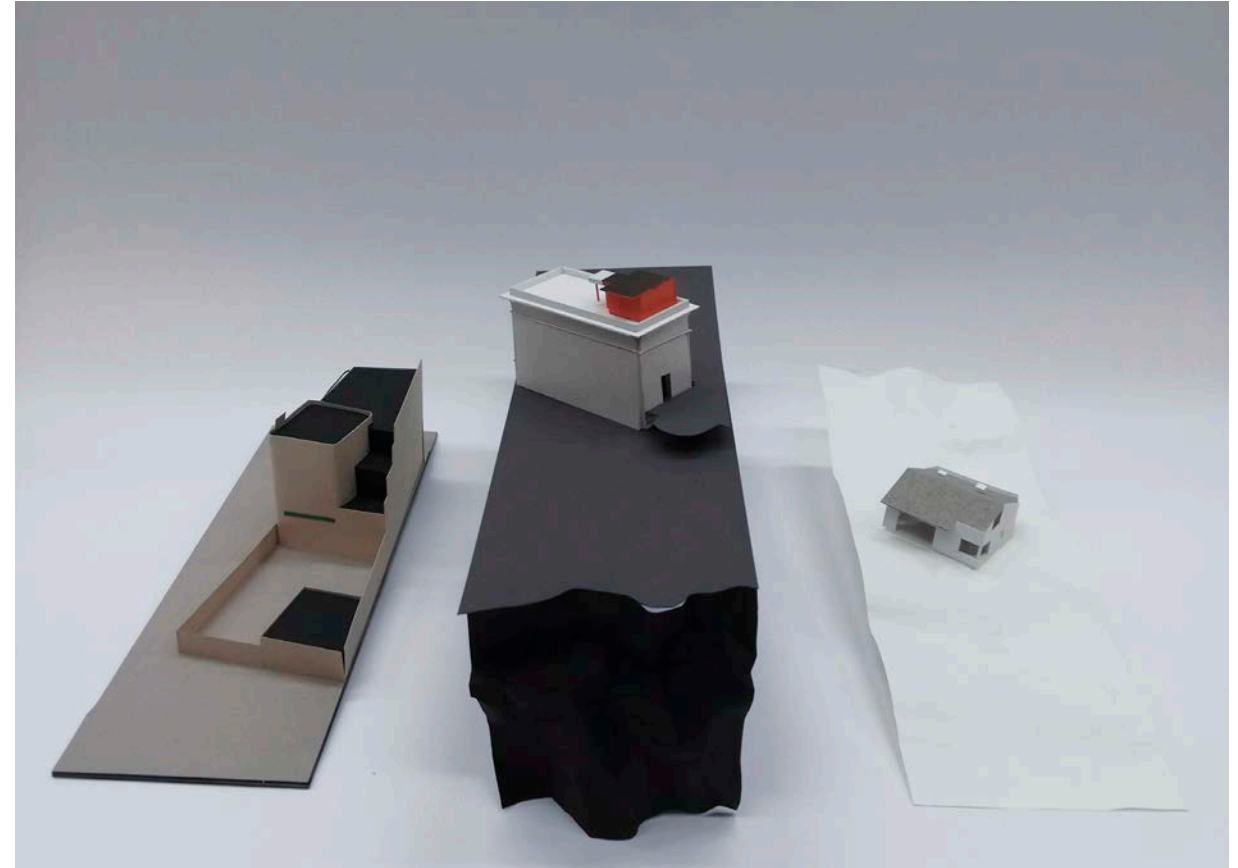

## chapter of novel

They call it their summer house.  
I call it winter house.

The nights when everything is  
shrouded in the dark and they sit  
next to the fire place to have a  
glass of wine force me to flee into  
another world.

My world.

I am hiding, crawling into my little  
ice cave, a crystal like window,  
a place closer to the sky than to  
the inside of the house. I imagine  
myself sitting in an ice princess  
castle beeing able to see the  
milky-way. A magic univers. The  
arguments and hate inside turn  
silent.

I am smiling. This house is like me.  
When it turns winter, it is hiding  
under a magic cloak of snow.

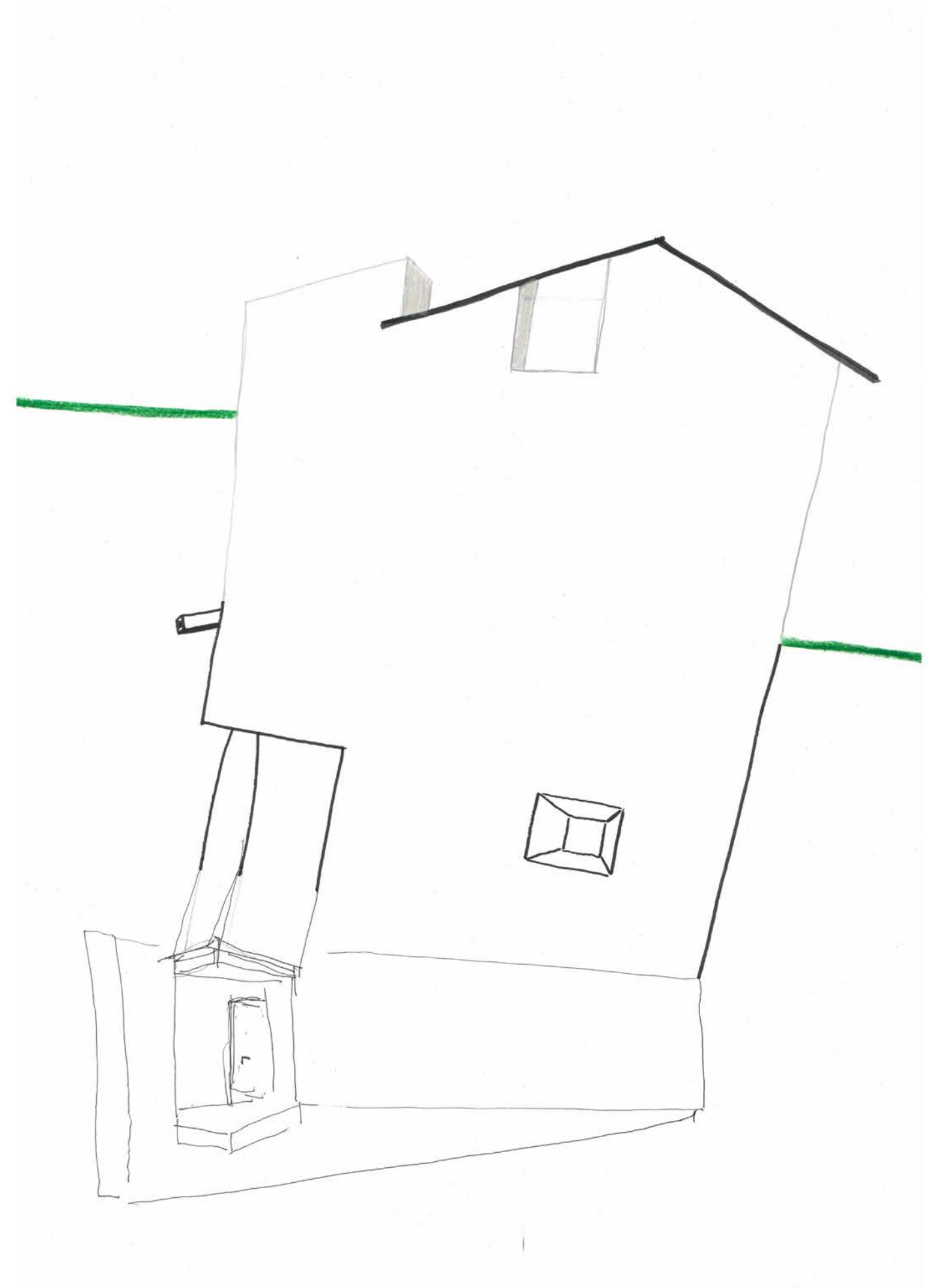

## chapter of novel

They call it their summer house. I call it winter house.

The nights when everything is shrouded in the dark and they sit next to the fire place to have a glass of wine force me to flee into another world.

My world.

I am hiding, crawling into my little ice cave, a crystal like window, a place closer to the sky than to the inside of the house. I imagine myself sitting in an ice princess castle beeing able to see the milky-way. A magic univers. The arguments and hate inside turn silent.

I am smiling. This house is like me. When it turns winter, it is hiding under a magic cloak of snow.

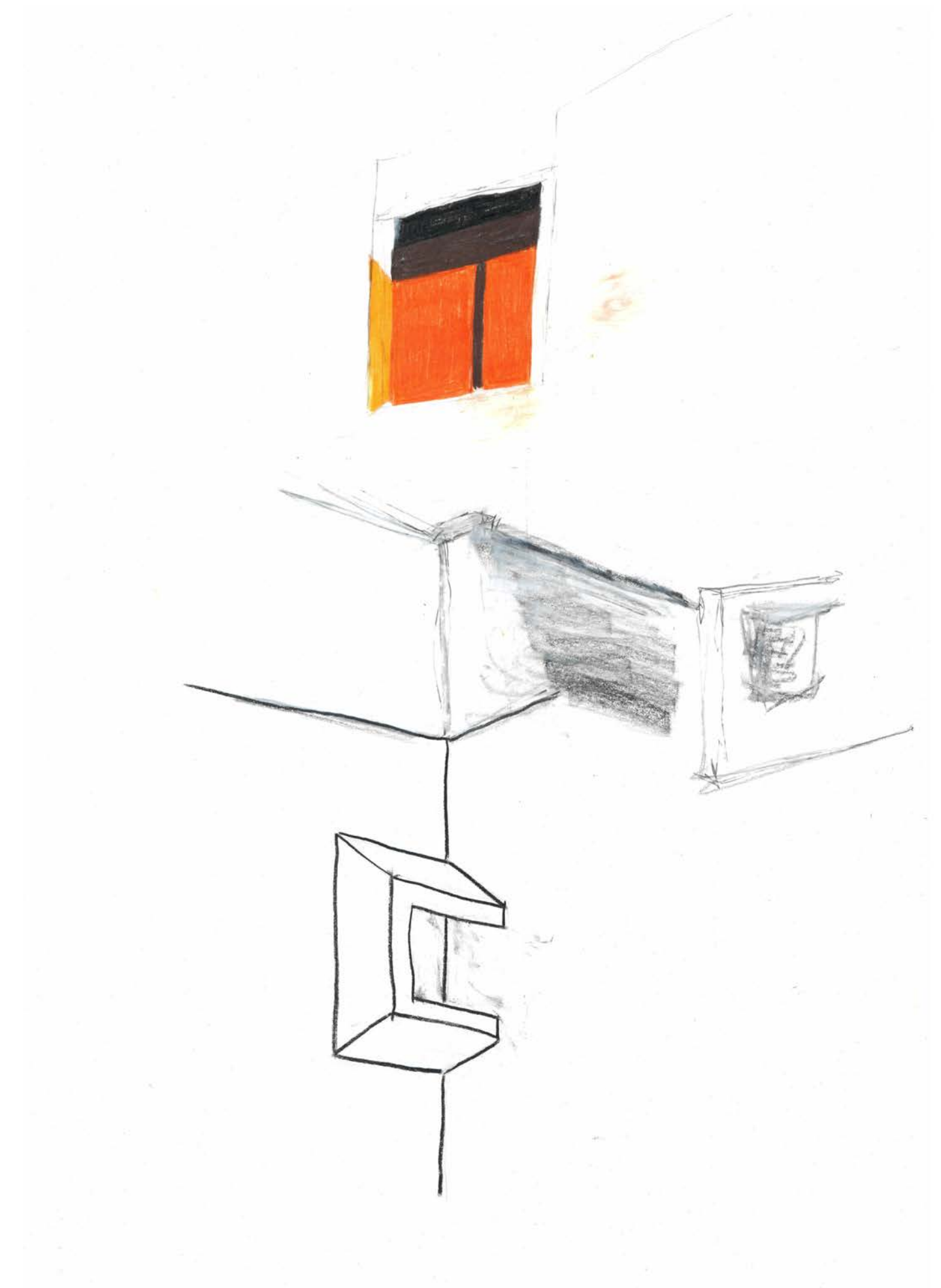

## chapter of novel

They call it their summer house. I call it winter house.

The nights when everything is shrouded in the dark and they sit next to the fire place to have a glass of wine force me to flee into another world.

My world.

I am hiding, crawling into my little ice cave, a crystal like window, a place closer to the sky than to the inside of the house. I imagine myself sitting in an ice princess castle beeing able to see the milky-way. A magic univers. The arguments and hate inside turn silent.

I am smiling. This house is like me. When it turns winter, it is hiding under a magic cloak of snow.

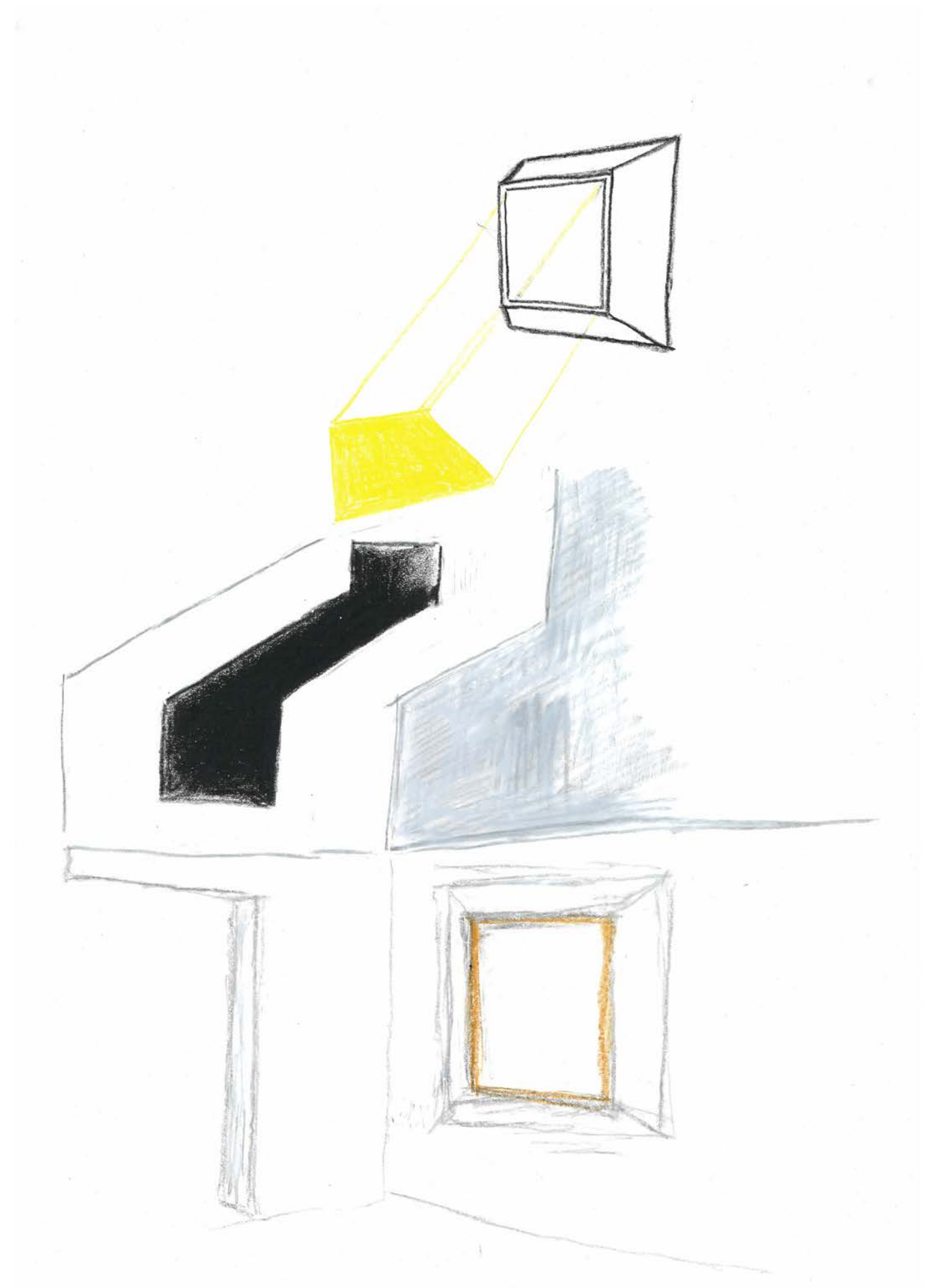

## chapter of novel

They call it their summer house. I call it winter house.

The nights when everything is shrouded in the dark and they sit next to the fire place to have a glass of wine force me to flee into another world.

My world.

I am hiding, crawling into my little ice cave, a crystal like window, a place closer to the sky than to the inside of the house. I imagine myself sitting in an ice princess castle beeing able to see the milky-way. A magic univers. The arguments and hate inside turn silent.

I am smiling. This house is like me. When it turns winter, it is hiding under a magic cloak of snow.

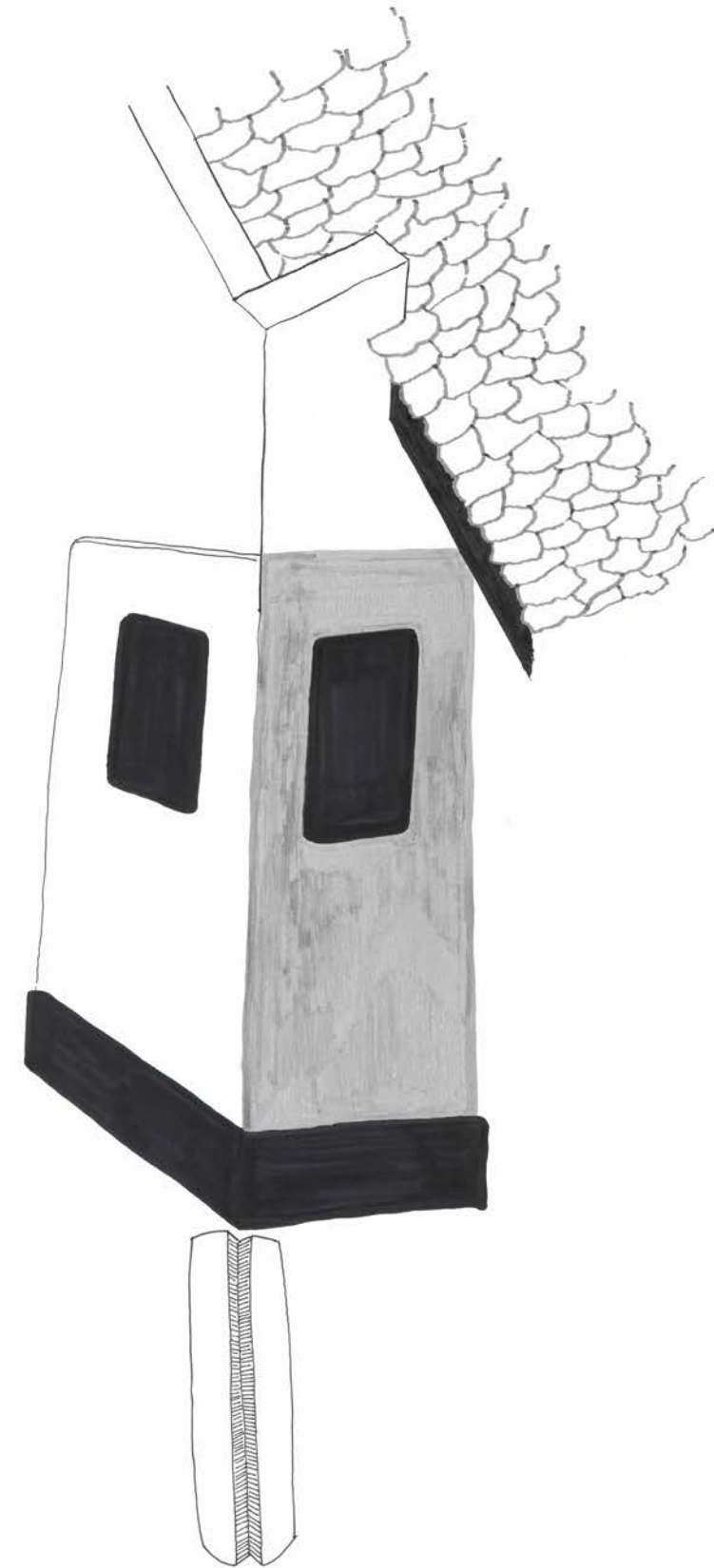



## chapter of novel

They call it their summer house. I call it winter house.

The nights when everything is shrouded in the dark and they sit next to the fire place to have a glass of wine force me to flee into another world.

My world.

I am hiding, crawling into my little ice cave, a crystal like window, a place closer to the sky than to the inside of the house. I imagine myself sitting in an ice princess castle beeing able to see the milky-way. A magic univers. The arguments and hate inside turn silent.

I am smiling. This house is like me. When it turns winter, it is hiding under a magic cloak of snow.

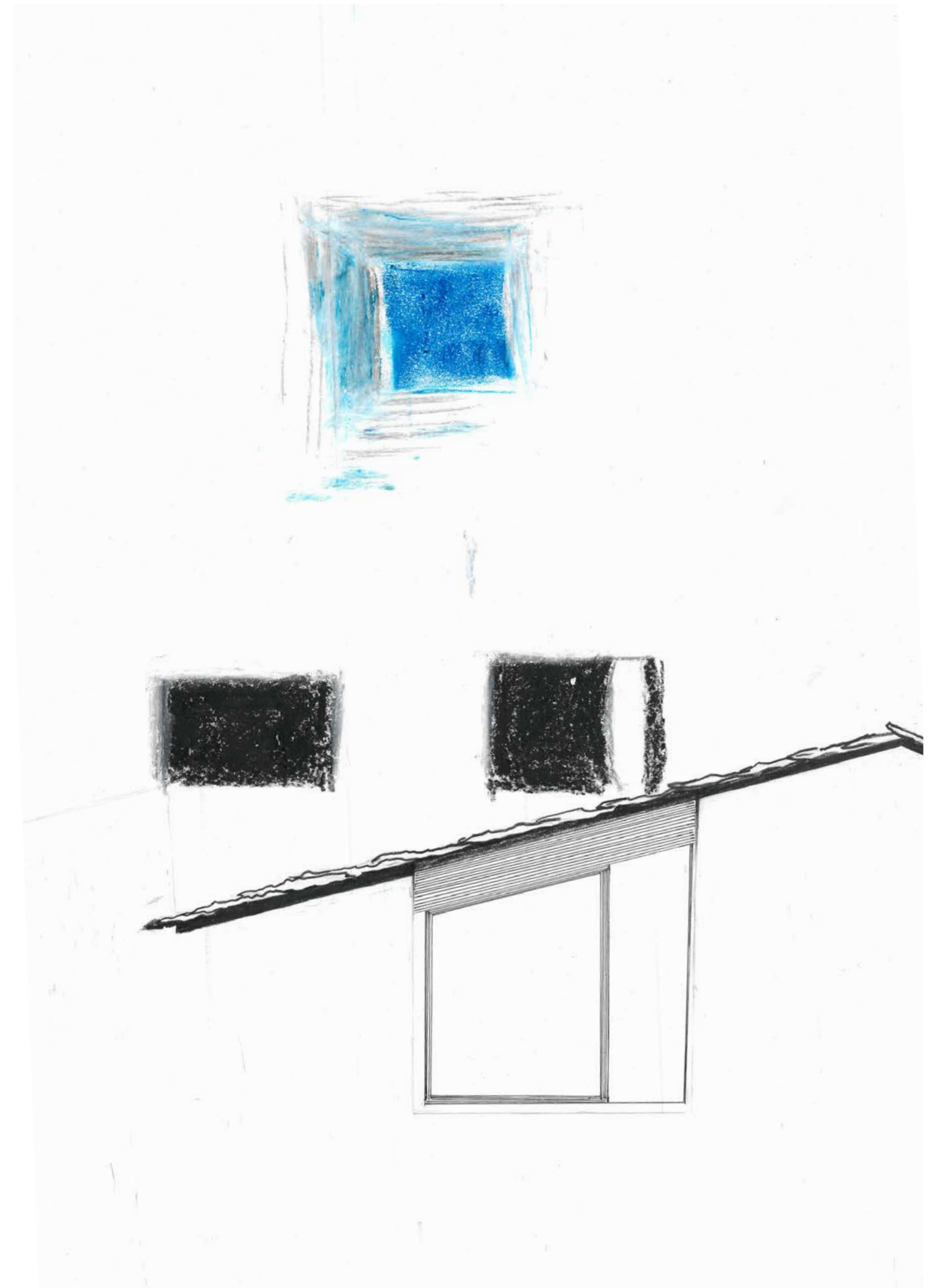

## chapter of novel

They call it their summer house. I call it winter house.

The nights when everything is shrouded in the dark and they sit next to the fire place to have a glass of wine force me to flee into another world.

My world.

I am hiding, crawling into my little ice cave, a crystal like window, a place closer to the sky than to the inside of the house. I imagine myself sitting in an ice princess castle beeing able to see the milky-way. A magic univers. The arguments and hate inside turn silent.

I am smiling. This house is like me. When it turns winter, it is hiding under a magic cloak of snow.

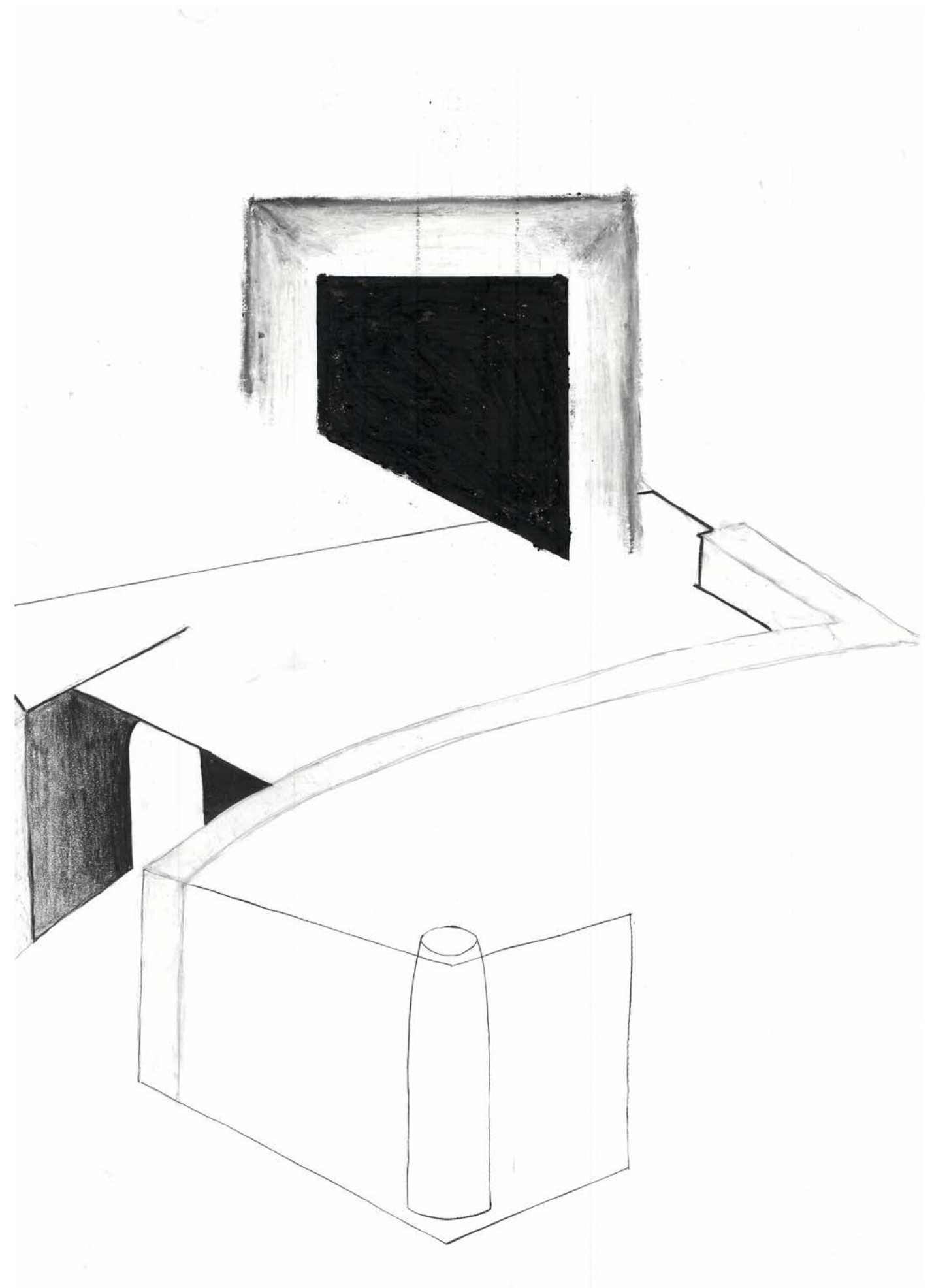

## chapter of novel

They call it their summer house. I call it winter house.

The nights when everything is shrouded in the dark and they sit next to the fire place to have a glass of wine force me to flee into another world.

My world.

I am hiding, crawling into my little ice cave, a crystal like window, a place closer to the sky than to the inside of the house. I imagine myself sitting in an ice princess castle beeing able to see the milky-way. A magic univers. The arguments and hate inside turn silent.

I am smiling. This house is like me. When it turns winter, it is hiding under a magic cloak of snow.

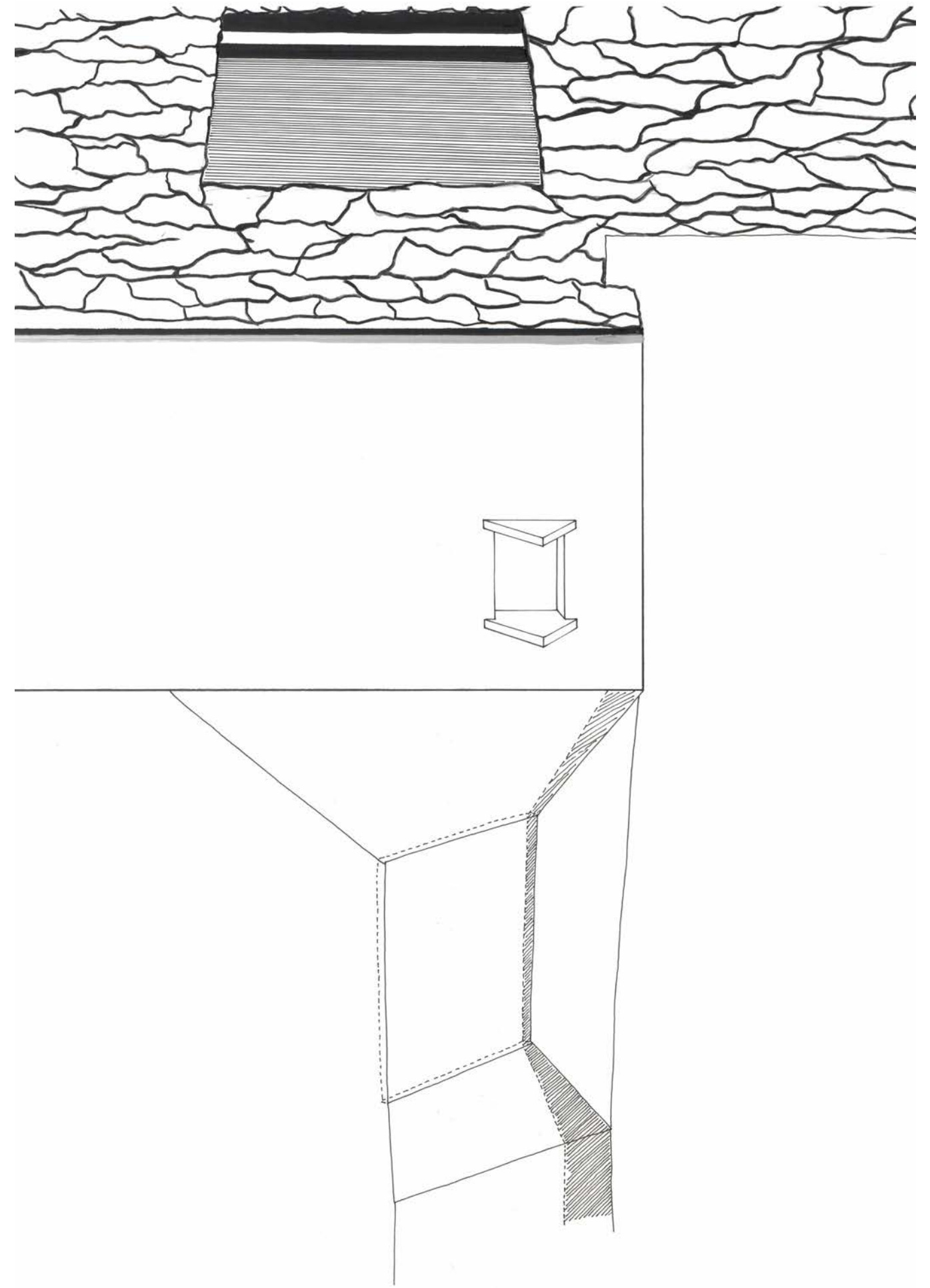

## chapter of novel

They call it their summer house. I call it winter house.

The nights when everything is shrouded in the dark and they sit next to the fire place to have a glass of wine force me to flee into another world.

My world.

I am hiding, crawling into my little ice cave, a crystal like window, a place closer to the sky than to the inside of the house. I imagine myself sitting in an ice princess castle beeing able to see the milky-way. A magic univers. The arguments and hate inside turn silent.

I am smiling. This house is like me. When it turns winter, it is hiding under a magic cloak of snow.

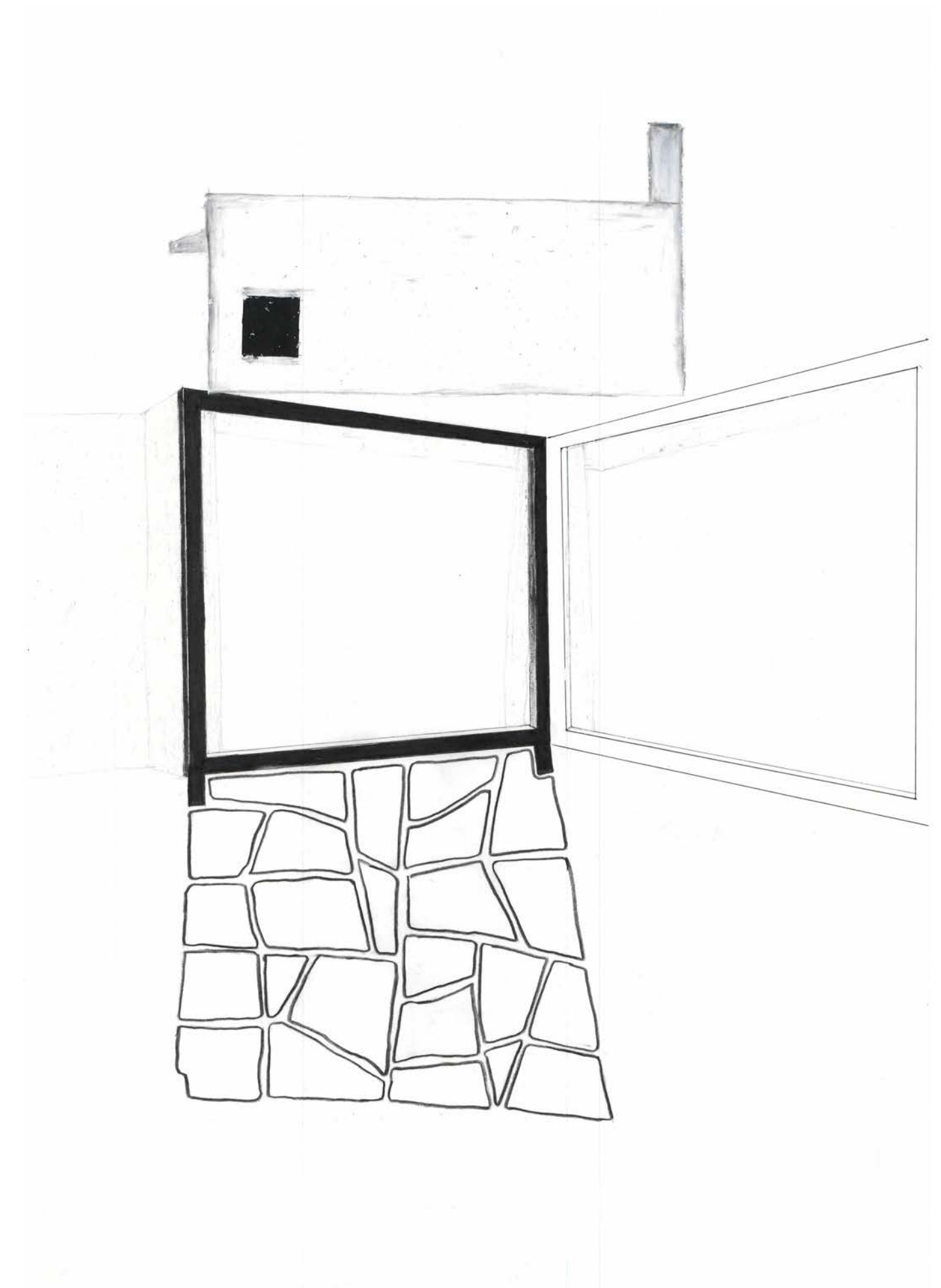



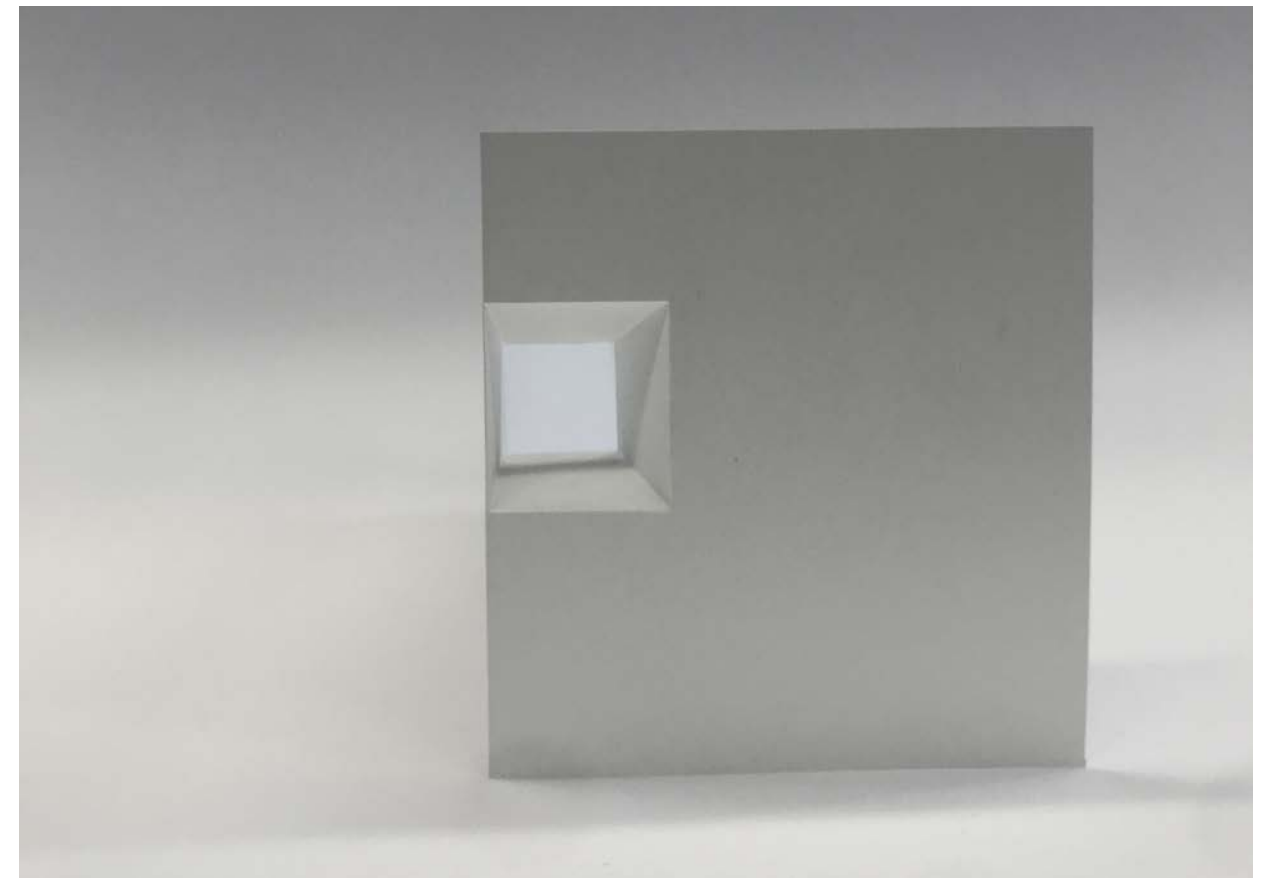
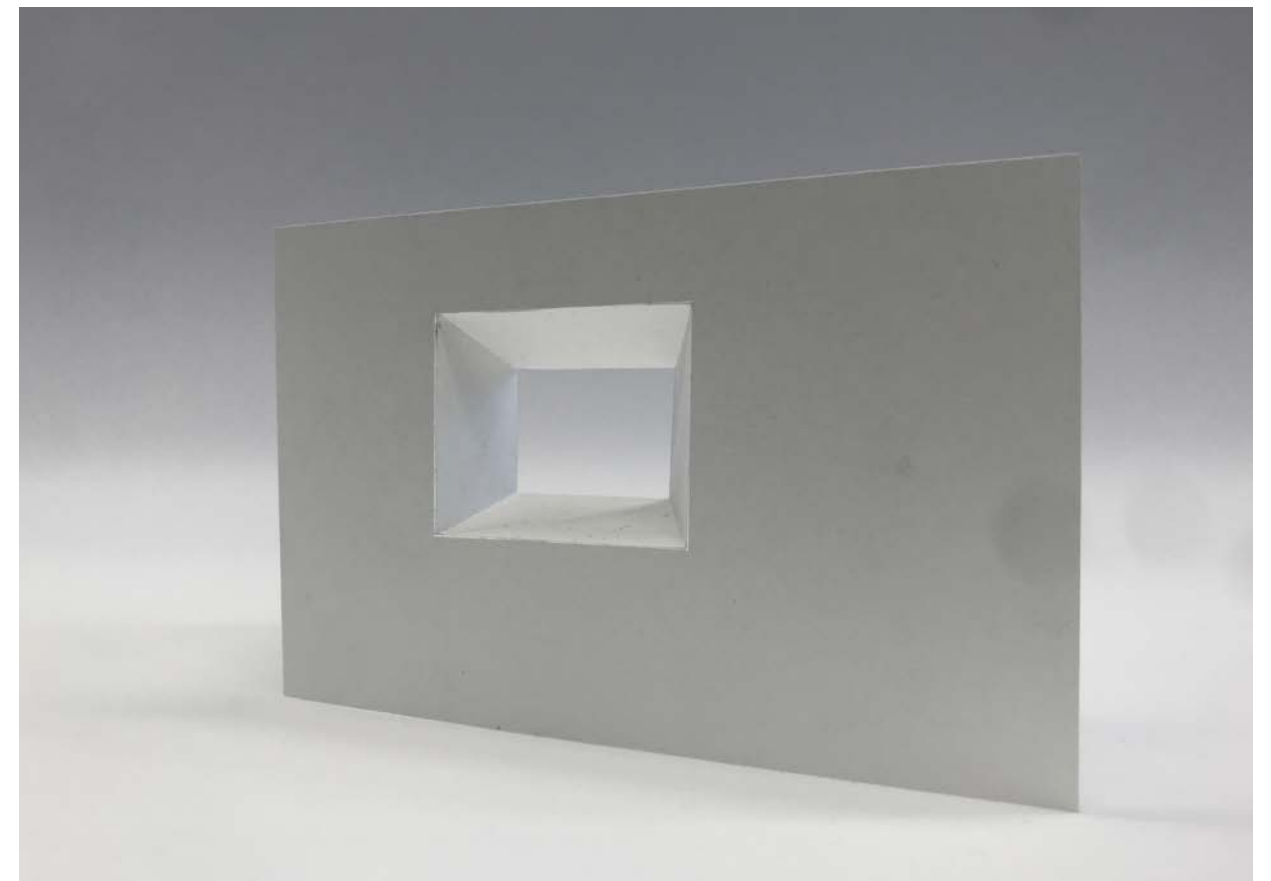
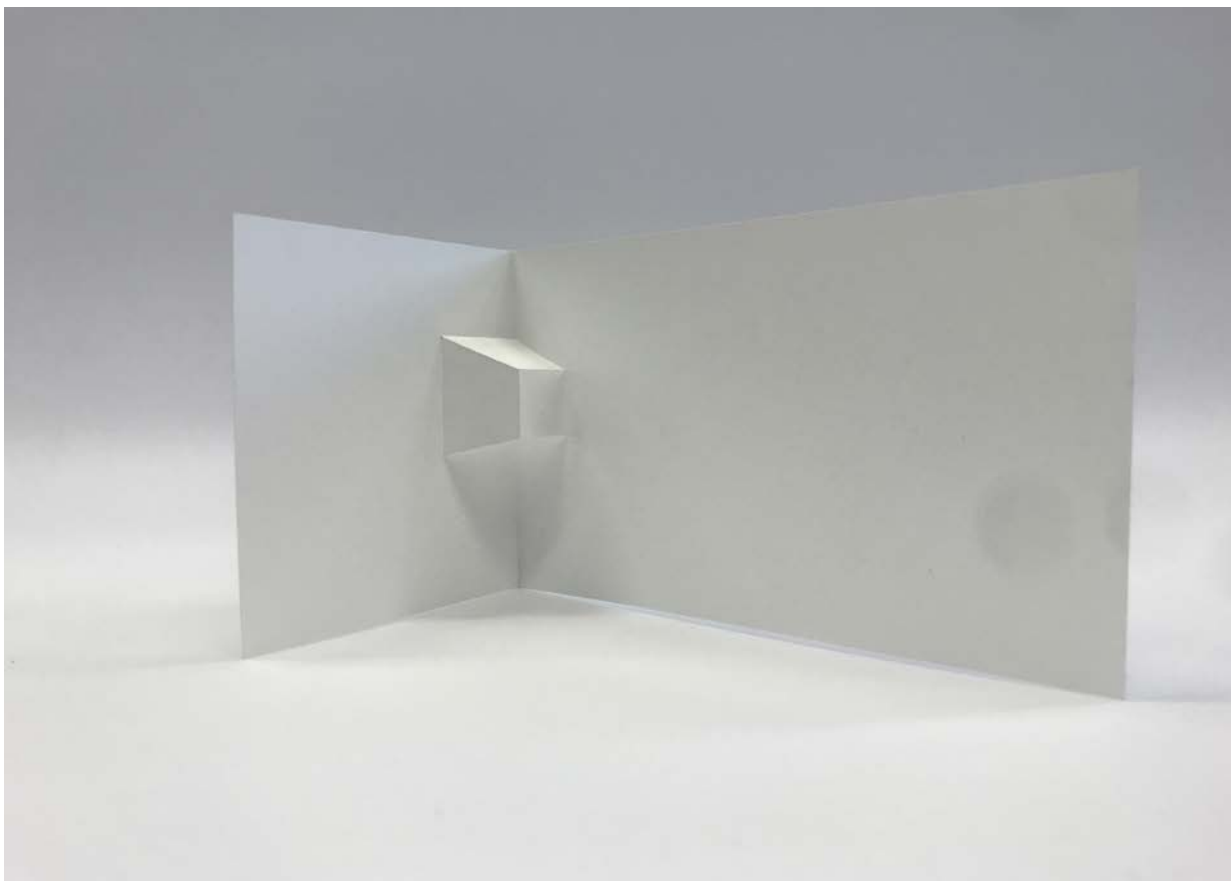

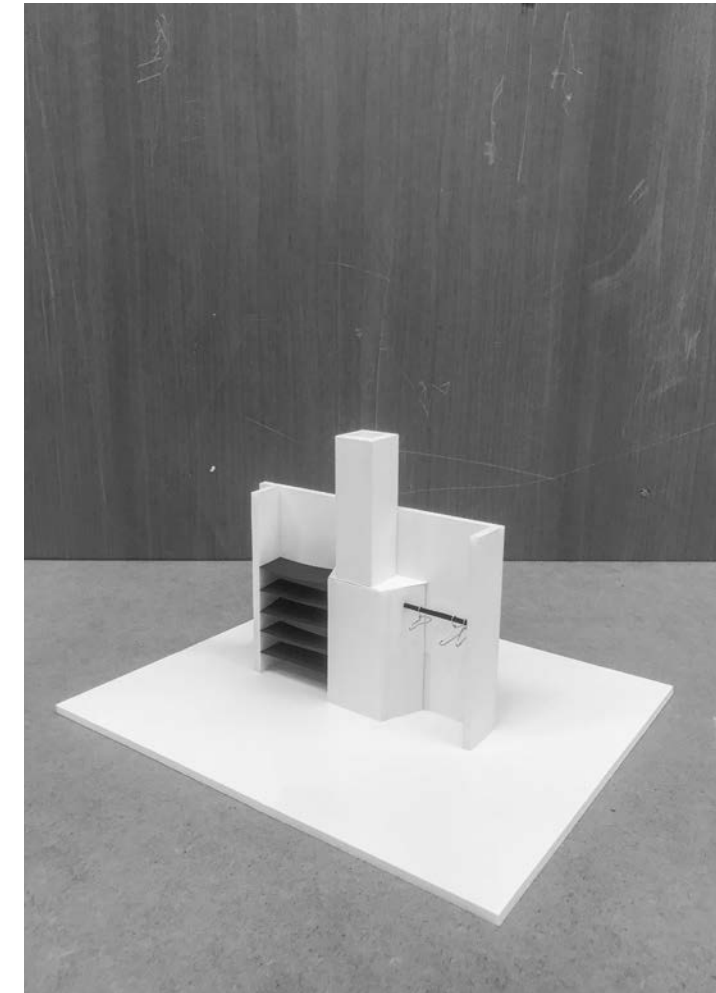
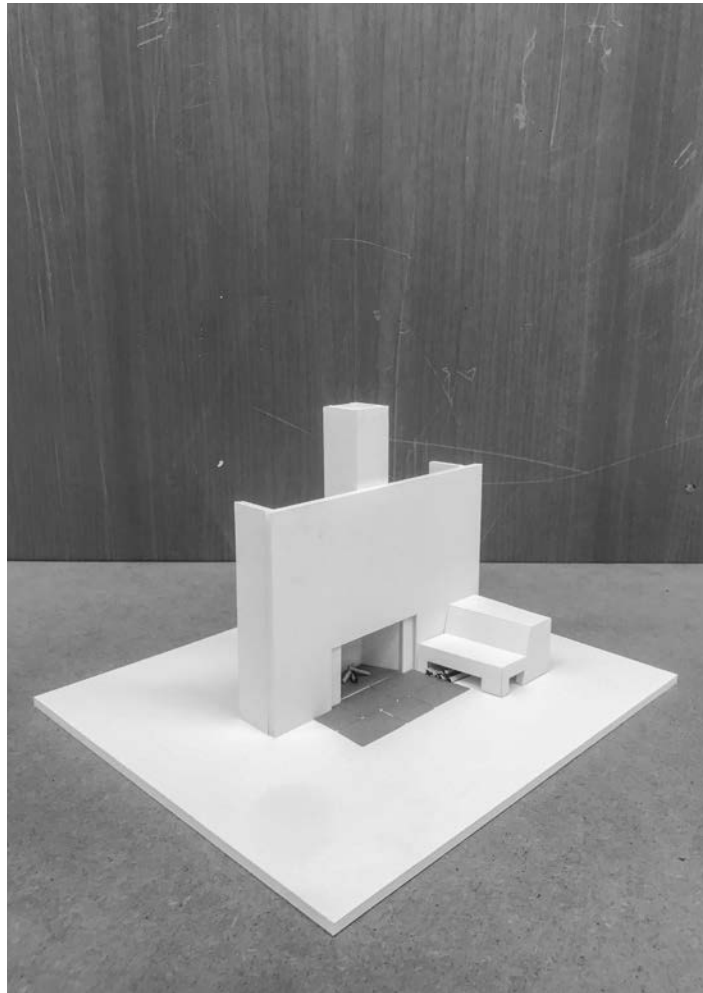

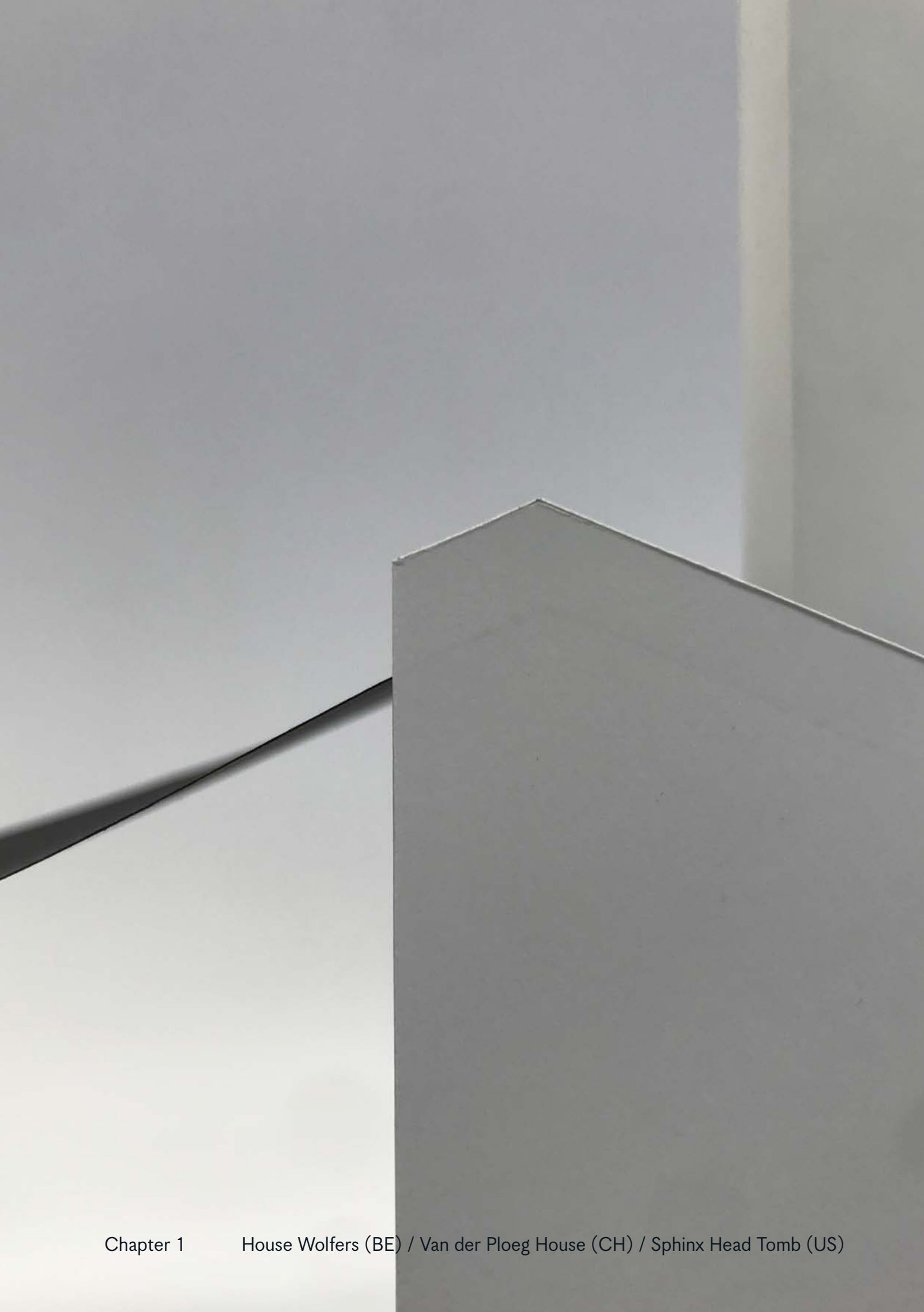





## chapter of novel

Almost every night I dare it now, since my sleep has become somewhat rare. Preferably though I'm tired enough and not under full consciousness so my sins feel slightly dampened.

It is in those nights the foreseen will become almost dreamlike. When i open the door to the big room, bit by bit having an ever growing light shadow unfolding itself around the corner of the dark shiny doorframe along the white painted wall, grasping for more and more darkness, almost like being fed by every centimeter of surface it's allowed to cover.

As the light does, i myself start to wrap my body around the door, very silent and cautious, always aware, until I'm standing there, inside the room i've again been longing for since my last visit.

Directly I target the fifth step, where the staircase meets with the beautifully rounded wall, almost like turning myself down into warm welcoming arms, I place my back against the curved wall, straighten my legs, let my had fall back just to gaze up through the skylight into the dark.



## chapter of novel

Almost every night I dare it now, since my sleep has become somewhat rare. Preferably though I'm tired enough and not under full consciousness so my sins feel slightly dampened.

It is in those nights the foreseen will become almost dreamlike. When i open the door to the big room, bit by bit having an ever growing light shadow unfolding itself around the corner of the dark shiny doorframe along the white painted wall, grasping for more and more darkness, almost like being fed by every centimeter of surface it's allowed to cover.

As the light does, i myself start to wrap my body around the door, very silent and cautious, always aware, until I'm standing there, inside the room i've again been longing for since my last visit.

Directly I target the fifth step, where the staircase meets with the beautifully rounded wall, almost like turning myself down into warm welcoming arms, I place my back against the curved wall, straighten my legs, let my had fall back just to gaze up through the skylight into the dark.

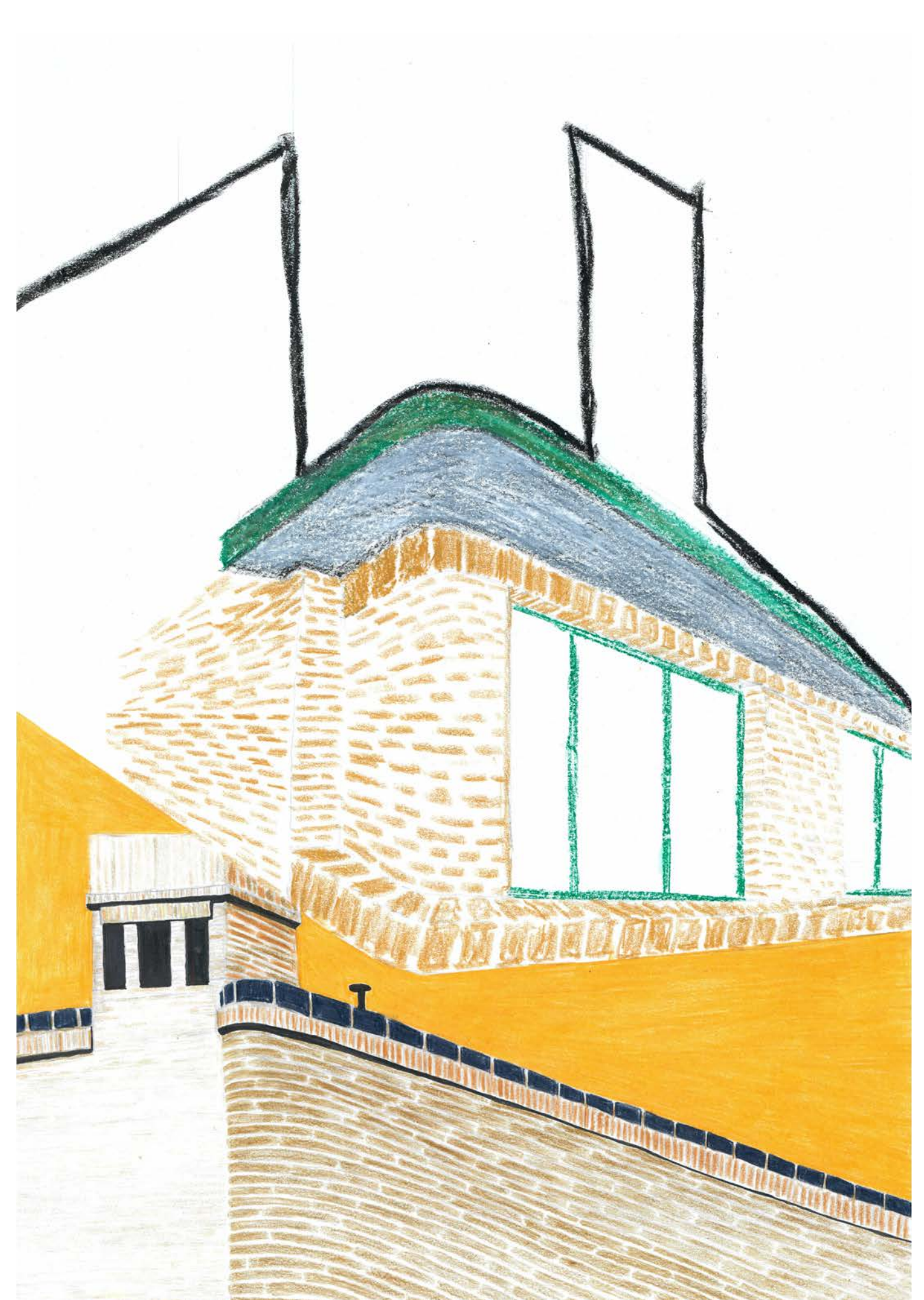

## chapter of novel

Almost every night I dare it now, since my sleep has become somewhat rare. Preferably though I'm tired enough and not under full consciousness so my sins feel slightly dampened.

It is in those nights the foreseen will become almost dreamlike. When i open the door to the big room, bit by bit having an ever growing light shadow unfolding itself around the corner of the dark shiny doorframe along the white painted wall, grasping for more and more darkness, almost like being fed by every centimeter of surface it's allowed to cover.

As the light does, i myself start to wrap my body around the door, very silent and cautious, always aware, until I'm standing there, inside the room i've again been longing for since my last visit.

Directly I target the fifth step, where the staircase meets with the beautifully rounded wall, almost like turning myself down into warm welcoming arms, I place my back against the curved wall, straighten my legs, let my had fall back just to gaze up through the skylight into the dark.

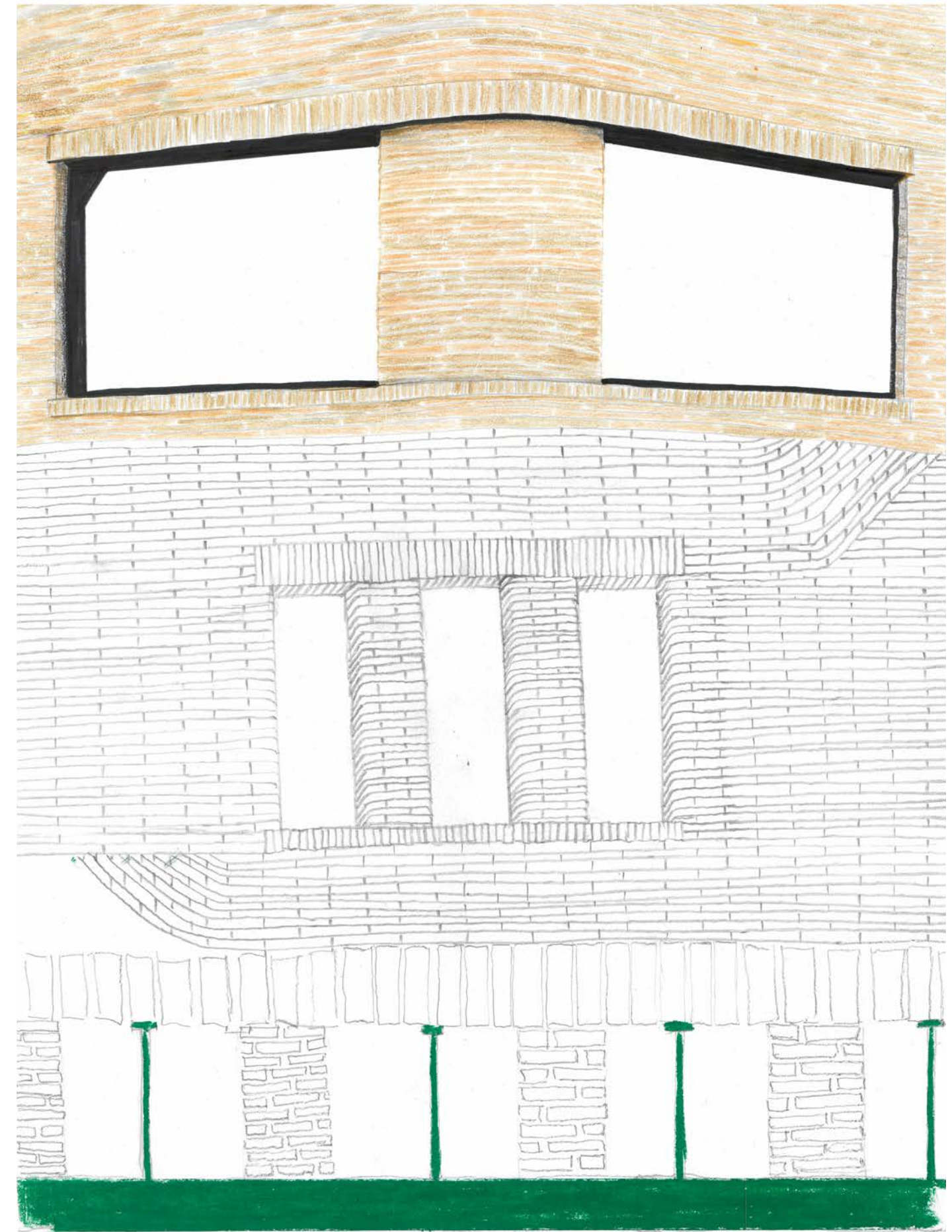

## chapter of novel

Almost every night I dare it now, since my sleep has become somewhat rare. Preferably though I'm tired enough and not under full consciousness so my sins feel slightly dampened.

It is in those nights the foreseen will become almost dreamlike. When i open the door to the big room, bit by bit having an ever growing light shadow unfolding itself around the corner of the dark shiny doorframe along the white painted wall, grasping for more and more darkness, almost like being fed by every centimeter of surface it's allowed to cover.

As the light does, i myself start to wrap my body around the door, very silent and cautious, always aware, until I'm standing there, inside the room i've again been longing for since my last visit.

Directly I target the fifth step, where the staircase meets with the beautifully rounded wall, almost like turning myself down into warm welcoming arms, I place my back against the curved wall, straighten my legs, let my had fall back just to gaze up through the skylight into the dark.

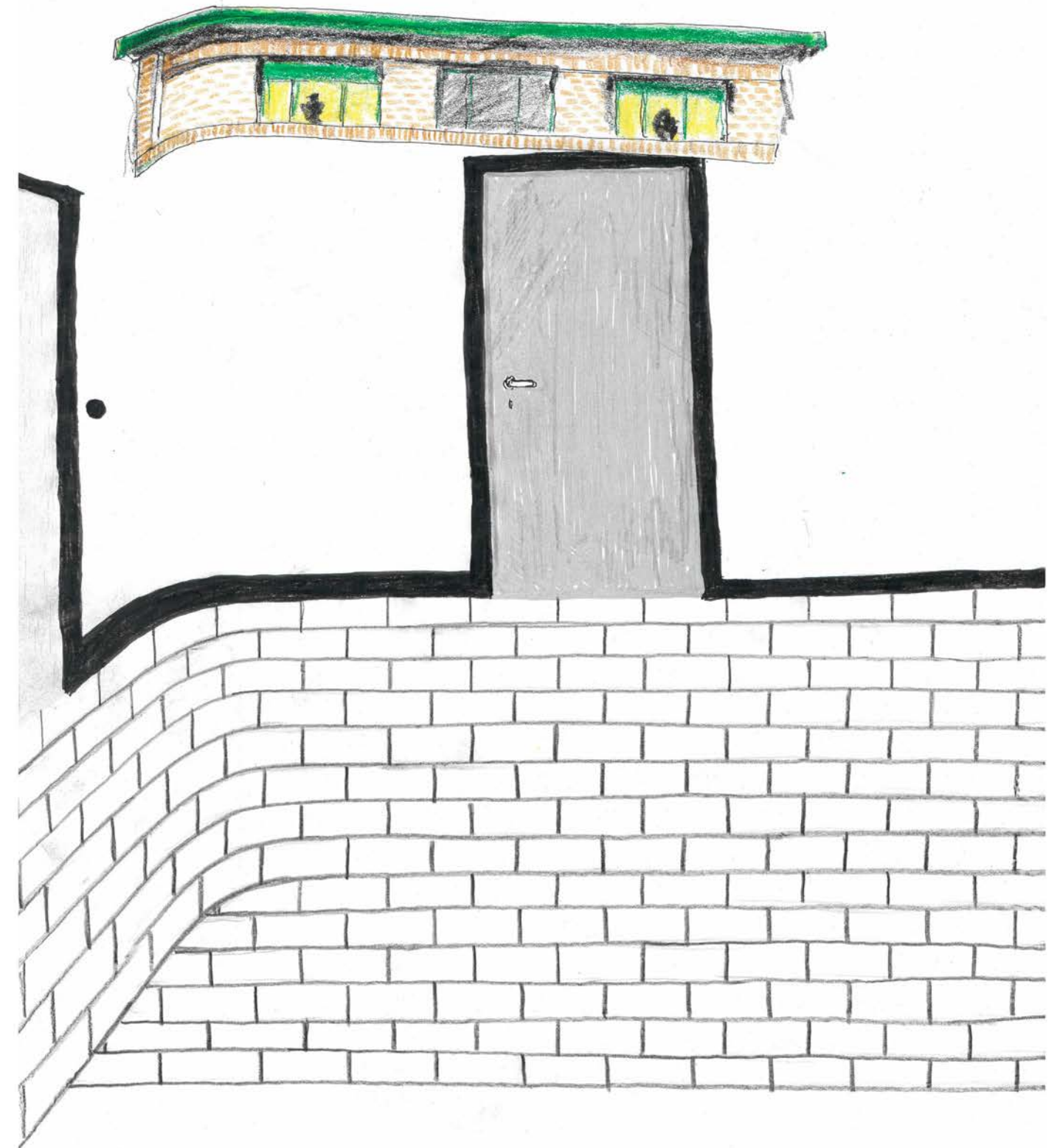

## chapter of novel

Almost every night I dare it now, since my sleep has become somewhat rare. Preferably though I'm tired enough and not under full consciousness so my sins feel slightly dampened.

It is in those nights the foreseen will become almost dreamlike. When i open the door to the big room, bit by bit having an ever growing light shadow unfolding itself around the corner of the dark shiny doorframe along the white painted wall, grasping for more and more darkness, almost like being fed by every centimeter of surface it's allowed to cover.

As the light does, i myself start to wrap my body around the door, very silent and cautious, always aware, until I'm standing there, inside the room i've again been longing for since my last visit.

Directly I target the fifth step, where the staircase meets with the beautifully rounded wall, almost like turning myself down into warm welcoming arms, I place my back against the curved wall, straighten my legs, let my had fall back just to gaze up through the skylight into the dark.

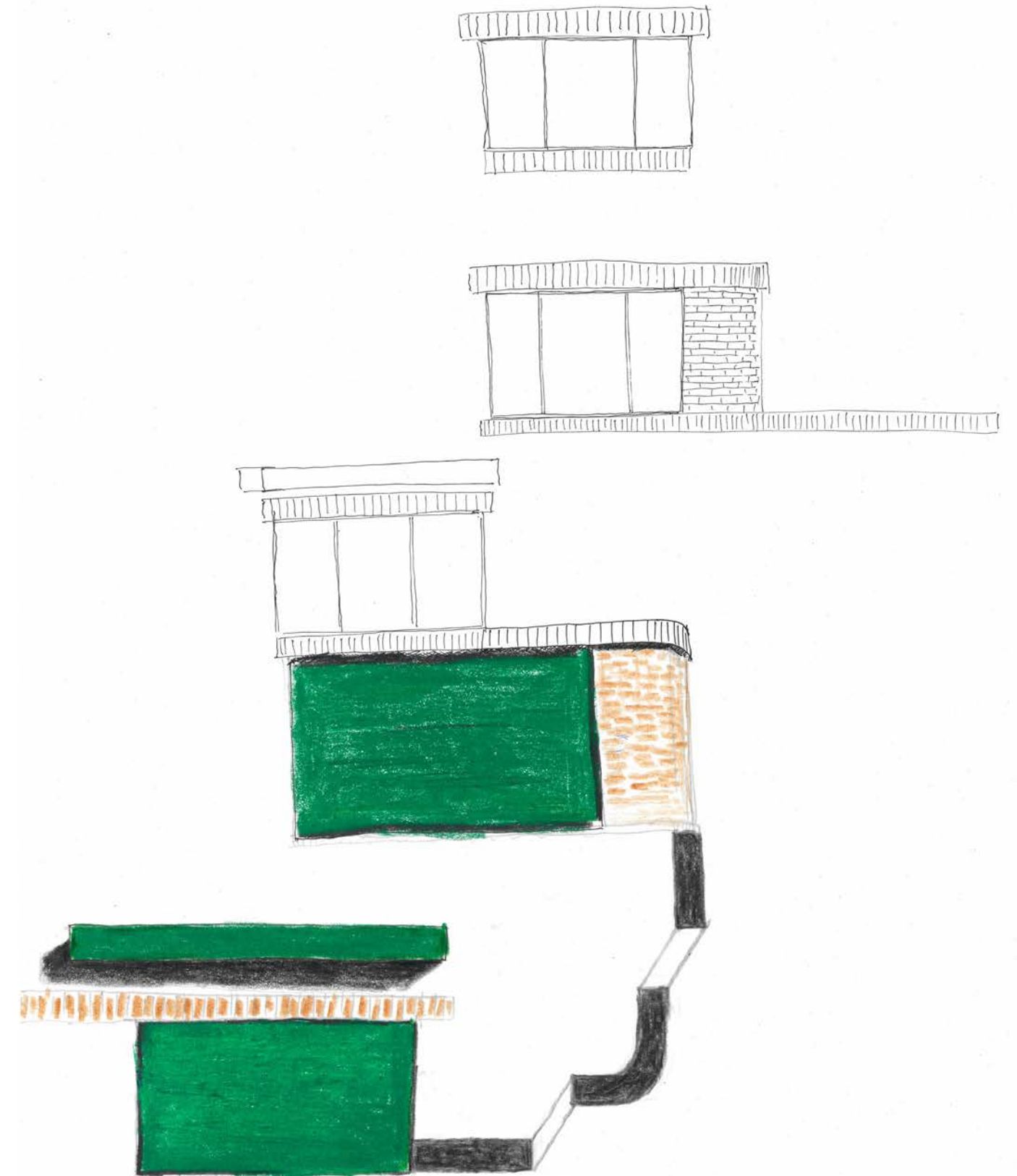

## chapter of novel

Almost every night I dare it now, since my sleep has become somewhat rare. Preferably though I'm tired enough and not under full consciousness so my sins feel slightly dampened.

It is in those nights the foreseen will become almost dreamlike. When i open the door to the big room, bit by bit having an ever growing light shadow unfolding itself around the corner of the dark shiny doorframe along the white painted wall, grasping for more and more darkness, almost like being fed by every centimeter of surface it's allowed to cover.

As the light does, i myself start to wrap my body around the door, very silent and cautious, always aware, until I'm standing there, inside the room i've again been longing for since my last visit.

Directly I target the fifth step, where the staircase meets with the beautifully rounded wall, almost like turning myself down into warm welcoming arms, I place my back against the curved wall, straighten my legs, let my had fall back just to gaze up through the skylight into the dark.

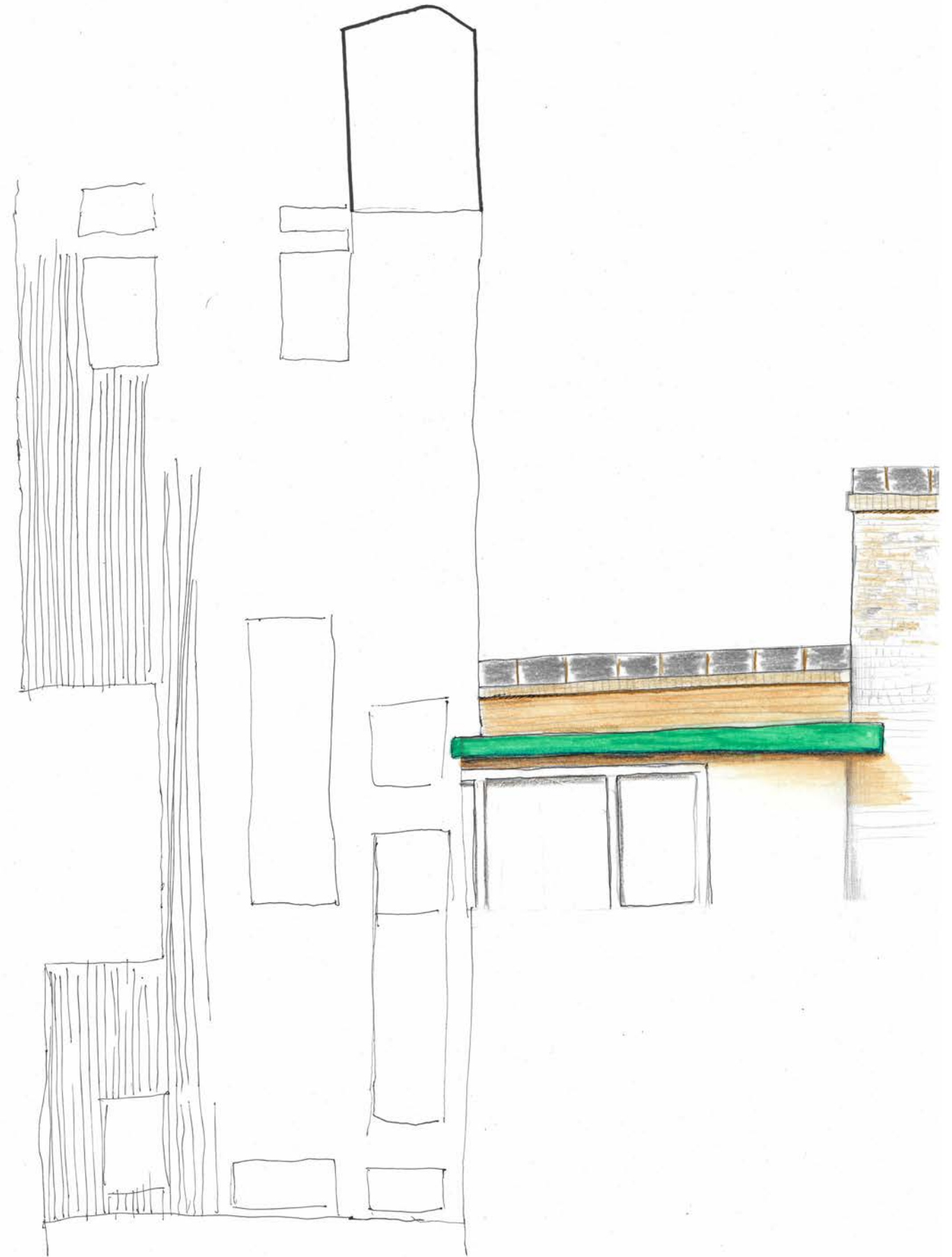

## chapter of novel

Almost every night I dare it now, since my sleep has become somewhat rare. Preferably though I'm tired enough and not under full consciousness so my sins feel slightly dampened.

It is in those nights the foreseen will become almost dreamlike. When i open the door to the big room, bit by bit having an ever growing light shadow unfolding itself around the corner of the dark shiny doorframe along the white painted wall, grasping for more and more darkness, almost like being fed by every centimeter of surface it's allowed to cover.

As the light does, i myself start to wrap my body around the door, very silent and cautious, always aware, until I'm standing there, inside the room i've again been longing for since my last visit.

Directly I target the fifth step, where the staircase meets with the beautifully rounded wall, almost like turning myself down into warm welcoming arms, I place my back against the curved wall, straighten my legs, let my had fall back just to gaze up through the skylight into the dark.

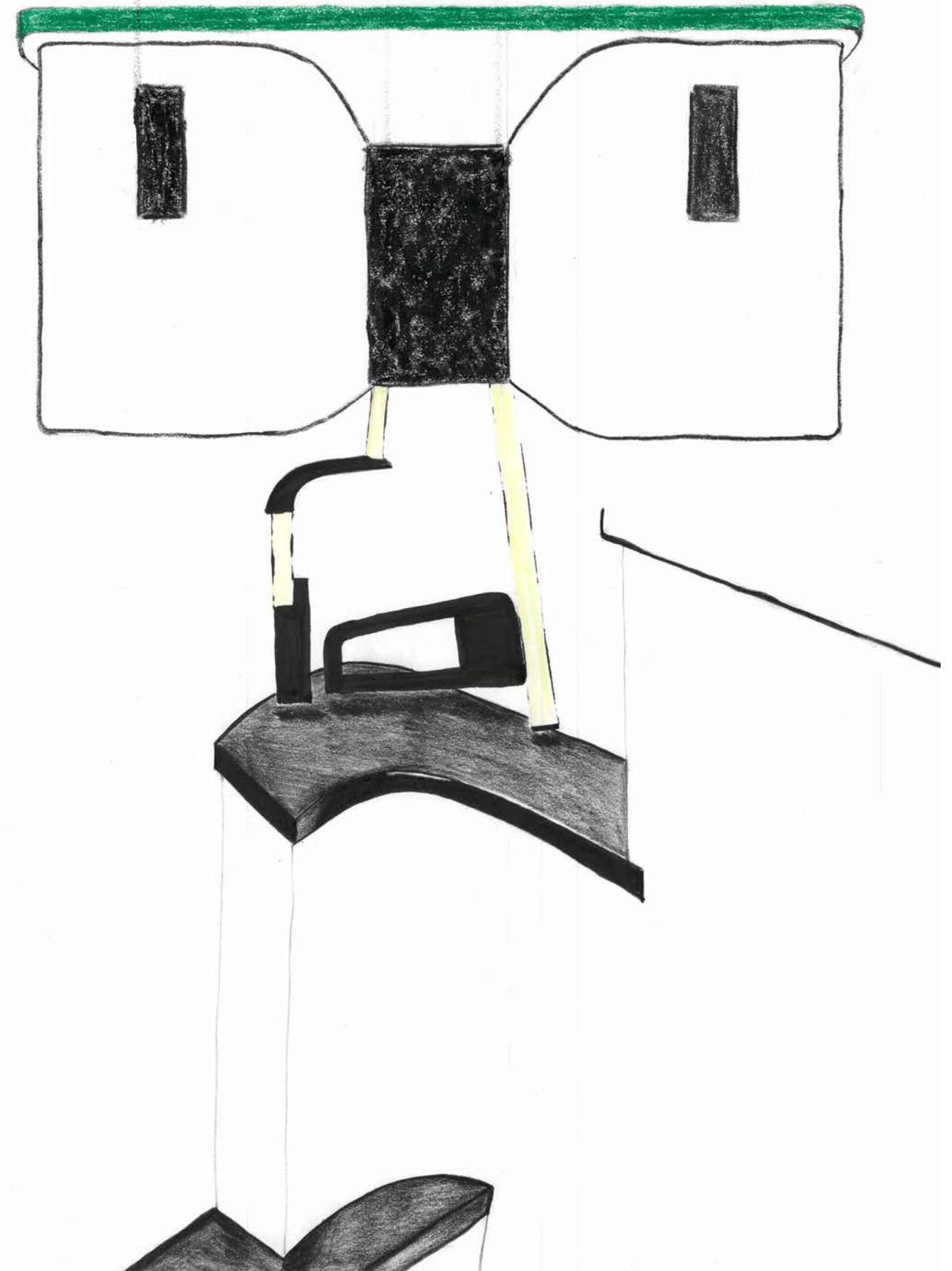



## chapter of novel

Almost every night I dare it now, since my sleep has become somewhat rare. Preferably though I'm tired enough and not under full consciousness so my sins feel slightly dampened.

It is in those nights the foreseen will become almost dreamlike. When i open the door to the big room, bit by bit having an ever growing light shadow unfolding itself around the corner of the dark shiny doorframe along the white painted wall, grasping for more and more darkness, almost like being fed by every centimeter of surface it's allowed to cover.

As the light does, i myself start to wrap my body around the door, very silent and cautious, always aware, until I'm standing there, inside the room i've again been longing for since my last visit.

Directly I target the fifth step, where the staircase meets with the beautifully rounded wall, almost like turning myself down into warm welcoming arms, I place my back against the curved wall, straighten my legs, let my had fall back just to gaze up through the skylight into the dark.

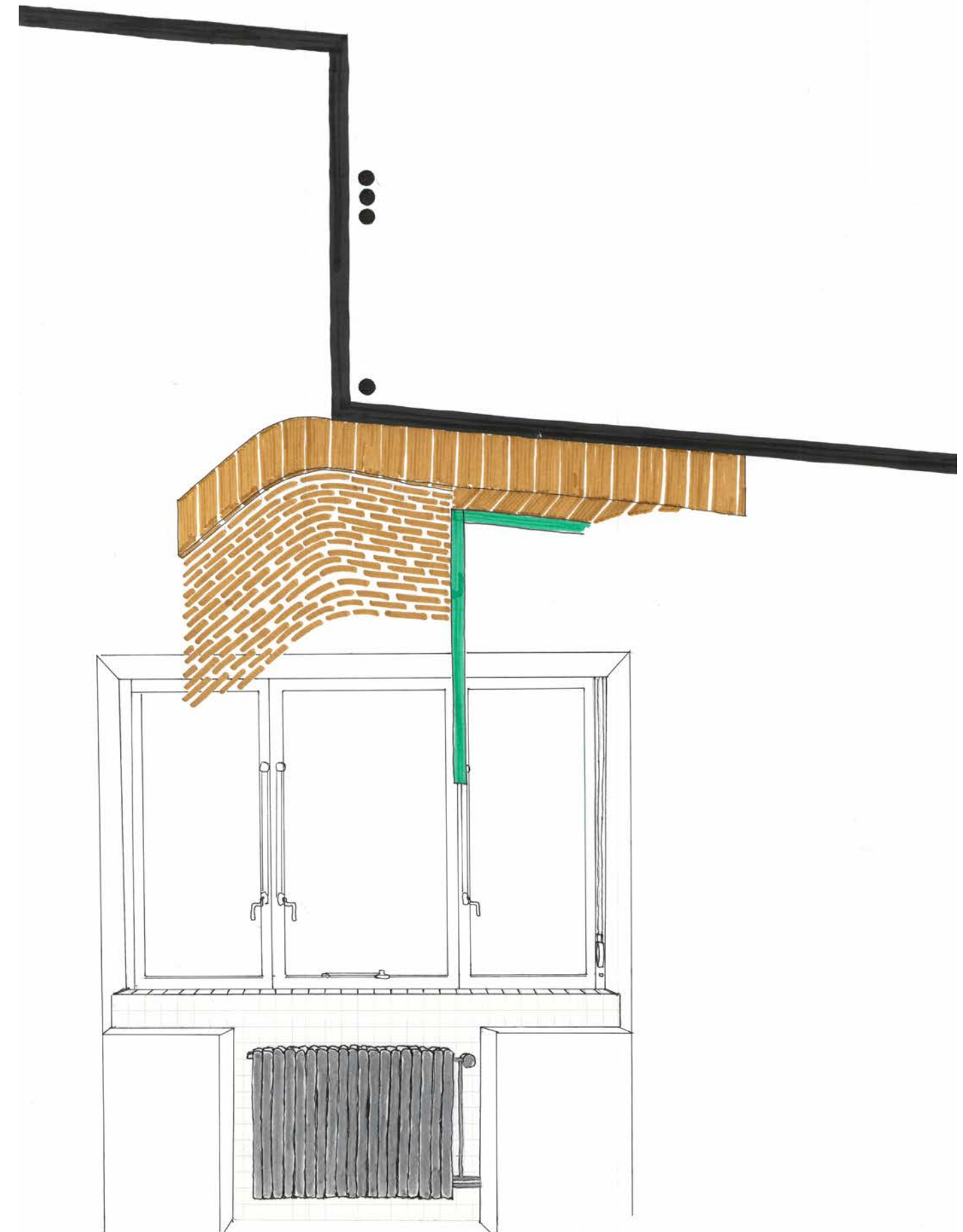

## chapter of novel

Almost every night I dare it now, since my sleep has become somewhat rare. Preferably though I'm tired enough and not under full consciousness so my sins feel slightly dampened.

It is in those nights the foreseen will become almost dreamlike. When i open the door to the big room, bit by bit having an ever growing light shadow unfolding itself around the corner of the dark shiny doorframe along the white painted wall, grasping for more and more darkness, almost like being fed by every centimeter of surface it's allowed to cover.

As the light does, i myself start to wrap my body around the door, very silent and cautious, always aware, until I'm standing there, inside the room i've again been longing for since my last visit.

Directly I target the fifth step, where the staircase meets with the beautifully rounded wall, almost like turning myself down into warm welcoming arms, I place my back against the curved wall, straighten my legs, let my had fall back just to gaze up through the skylight into the dark.







Chapter 1 House Wolfer (BE) / Van der Ploeg House (CH) / Sphinx Head Tomb (US)



Heuer, Henrike / Weber, Carmino / Vonder Mühl, Tobias



Chapter 1 House Wolfer (BE) / Van der Ploeg House (CH) / Sphinx Head Tomb (US)



Heuer, Henrike / Weber, Carmino / Vonder Mühl, Tobias

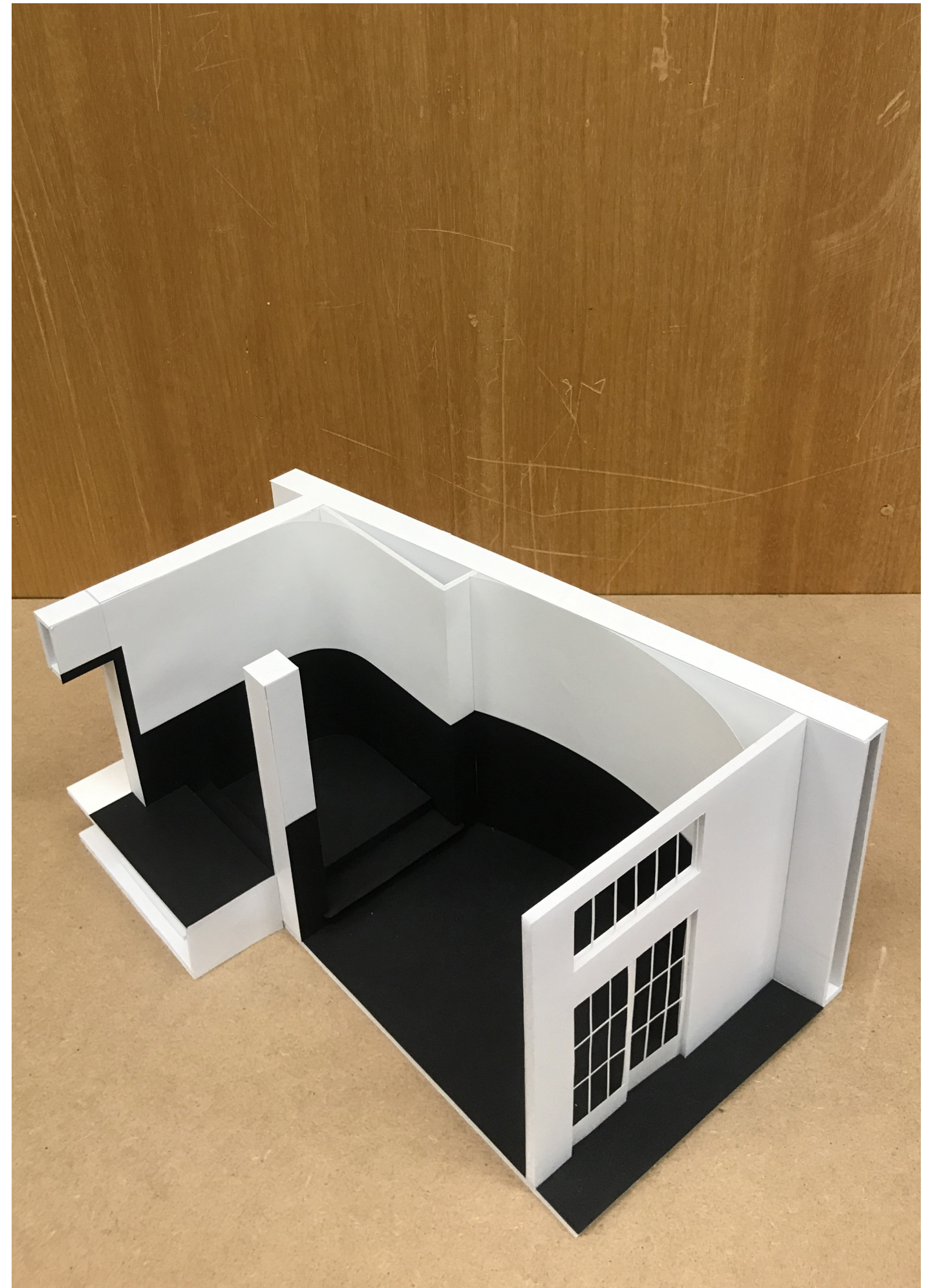



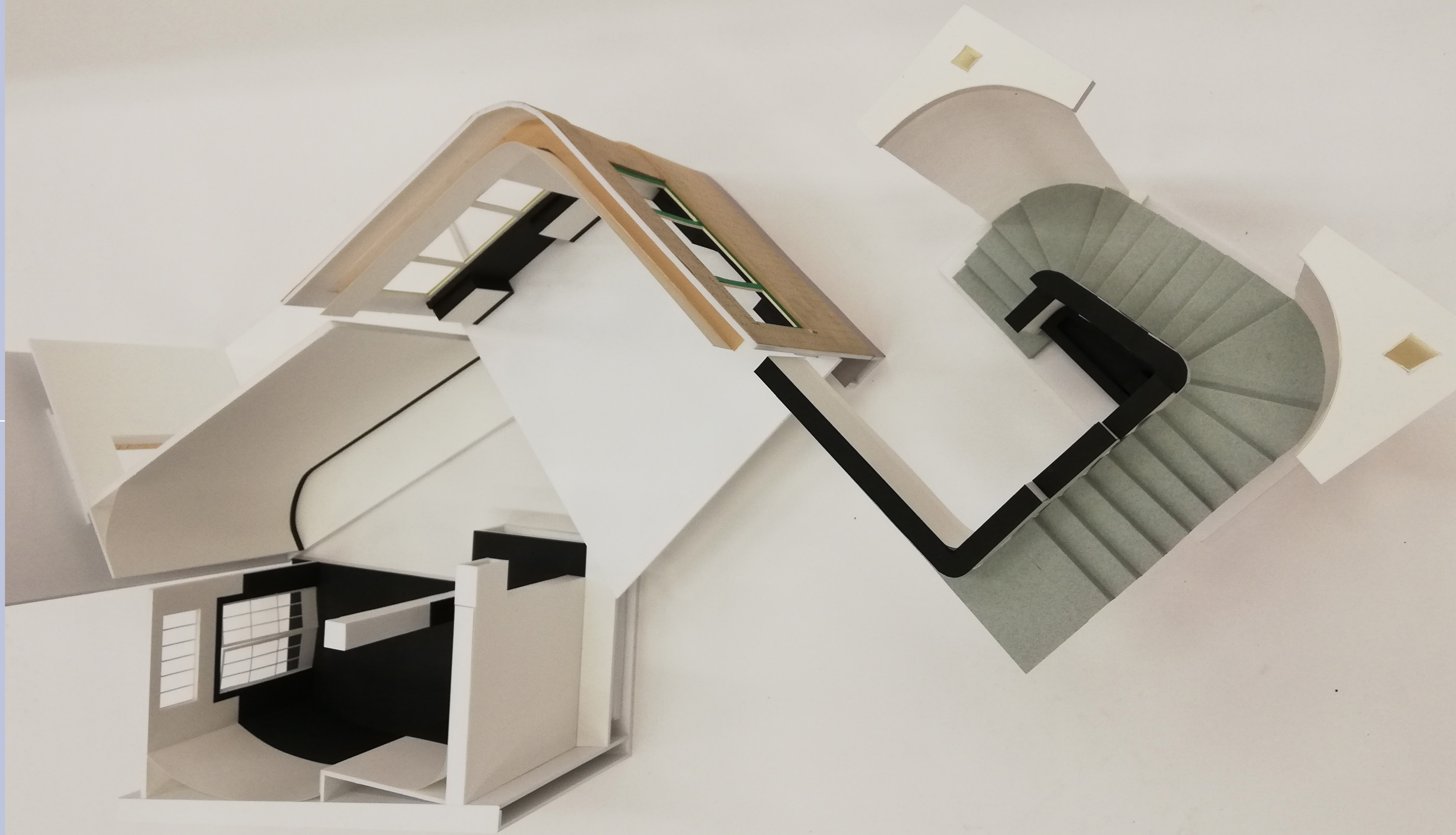



# Abysses

Some people think, that to evict demons, curses and death it needs dark rituals full of fire, blood and mantras.

They sacrifice frogs and rats and other creatures. They dance and murmur, they talk to earth and other elements.

Madness, delusion and illusion take possession of their soul.

Sometimes all this goes wrong and they become monsters, murderer, beasts.

All of this happened in this little tomb, in the dark grave. - Until someone came to cut life into the dead walls.

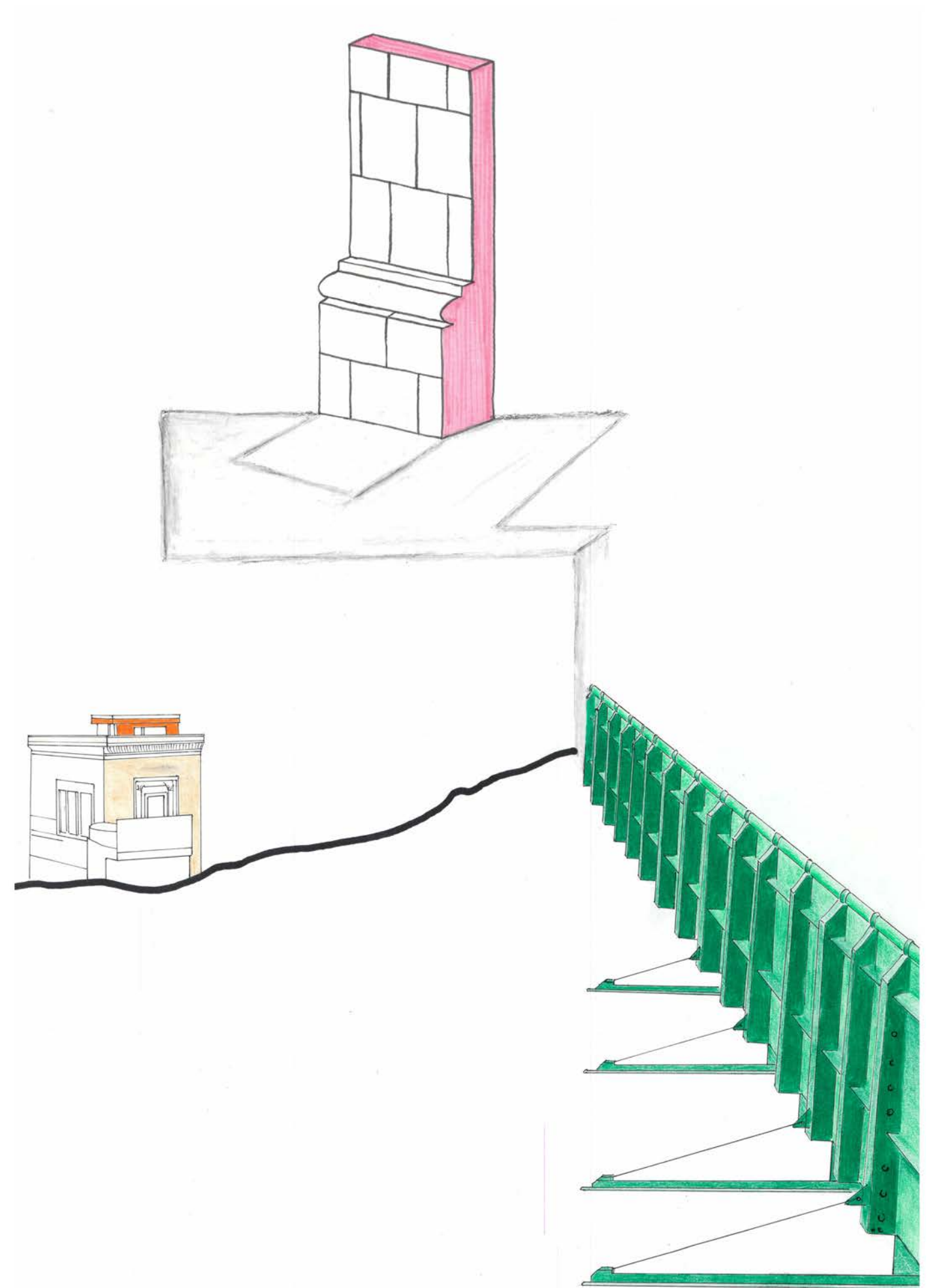

# Abysses

Some people think, that to evict demons, curses and death it needs dark rituals full of fire, blood and mantras.

They sacrifice frogs and rats and other creatures. They dance and murmur, they talk to earth and other elements.

Madness, delusion and illusion take possession of their soul.

Sometimes all this goes wrong and they become monsters, murderer, beasts.

All of this happened in this little tomb, in the dark grave. - Until someone came to cut life into the dead walls.

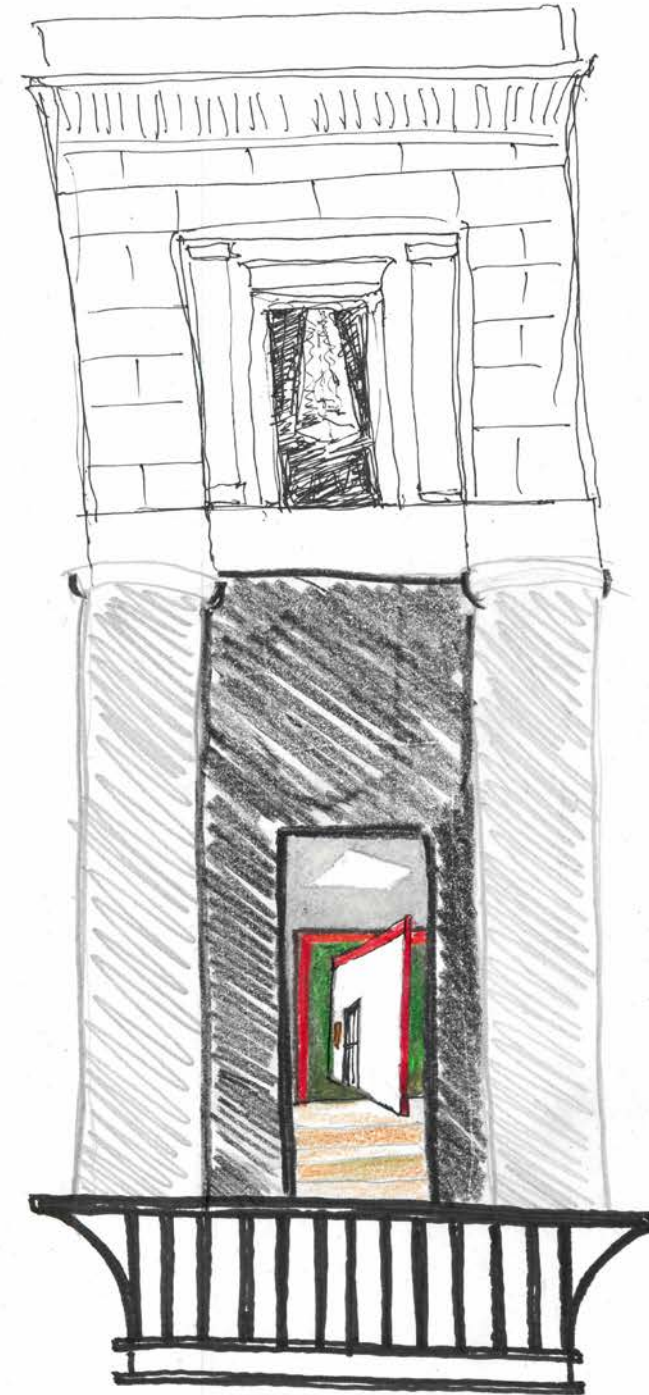

# Abysses

Some people think, that to evict demons, curses and death it needs dark rituals full of fire, blood and mantras.

They sacrifice frogs and rats and other creatures. They dance and murmur, they talk to earth and other elements.

Madness, delusion and illusion take possession of their soul.

Sometimes all this goes wrong and they become monsters, murderer, beasts.

All of this happened in this little tomb, in the dark grave. - Until someone came to cut life into the dead walls.

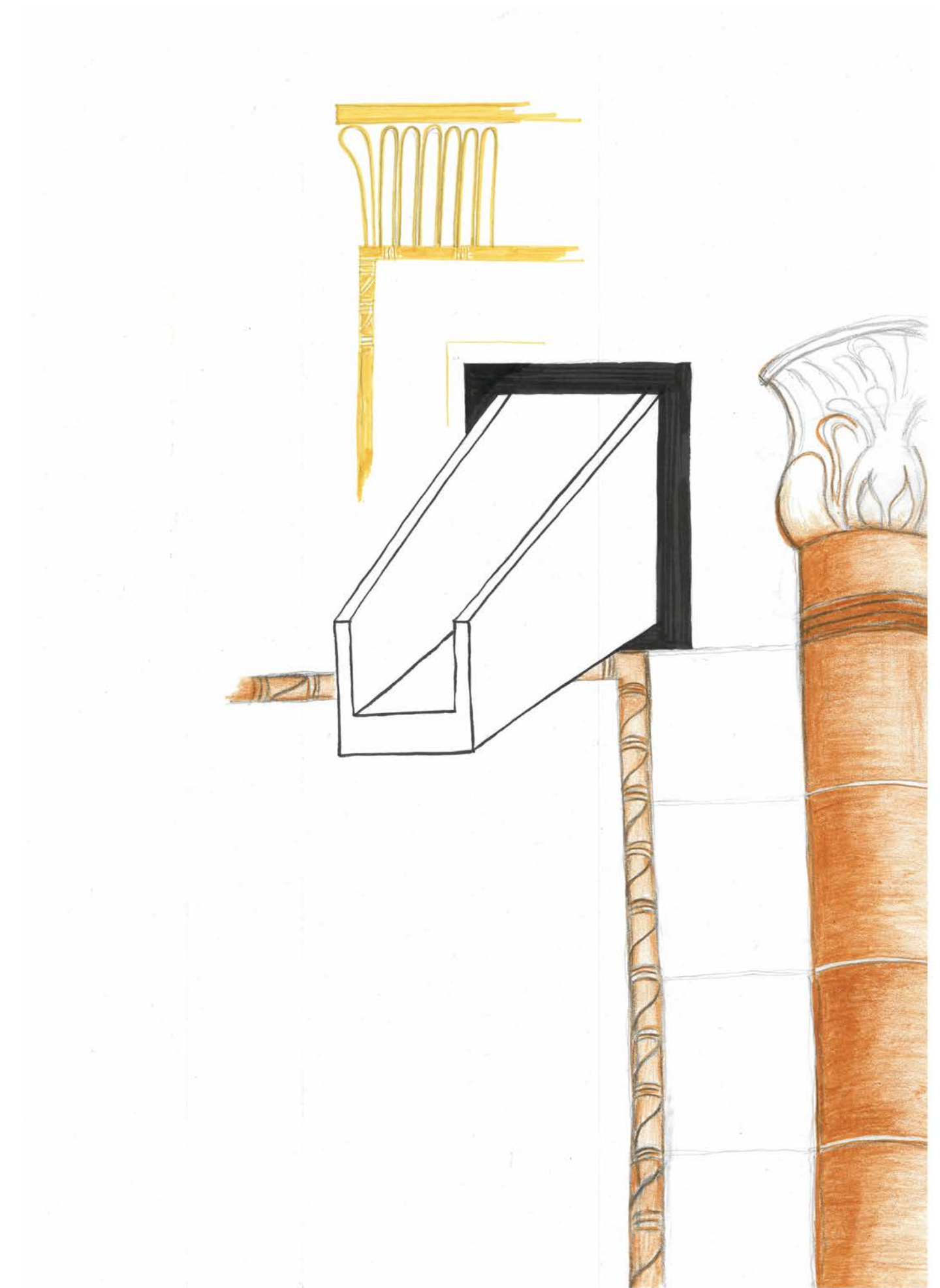

# Abysses

Some people think, that to evict demons, curses and death it needs dark rituals full of fire, blood and mantras.

They sacrifice frogs and rats and other creatures. They dance and murmur, they talk to earth and other elements.

Madness, delusion and illusion take possession of their soul.

Sometimes all this goes wrong and they become monsters, murderer, beasts.

All of this happened in this little tomb, in the dark grave. - Until someone came to cut life into the dead walls.

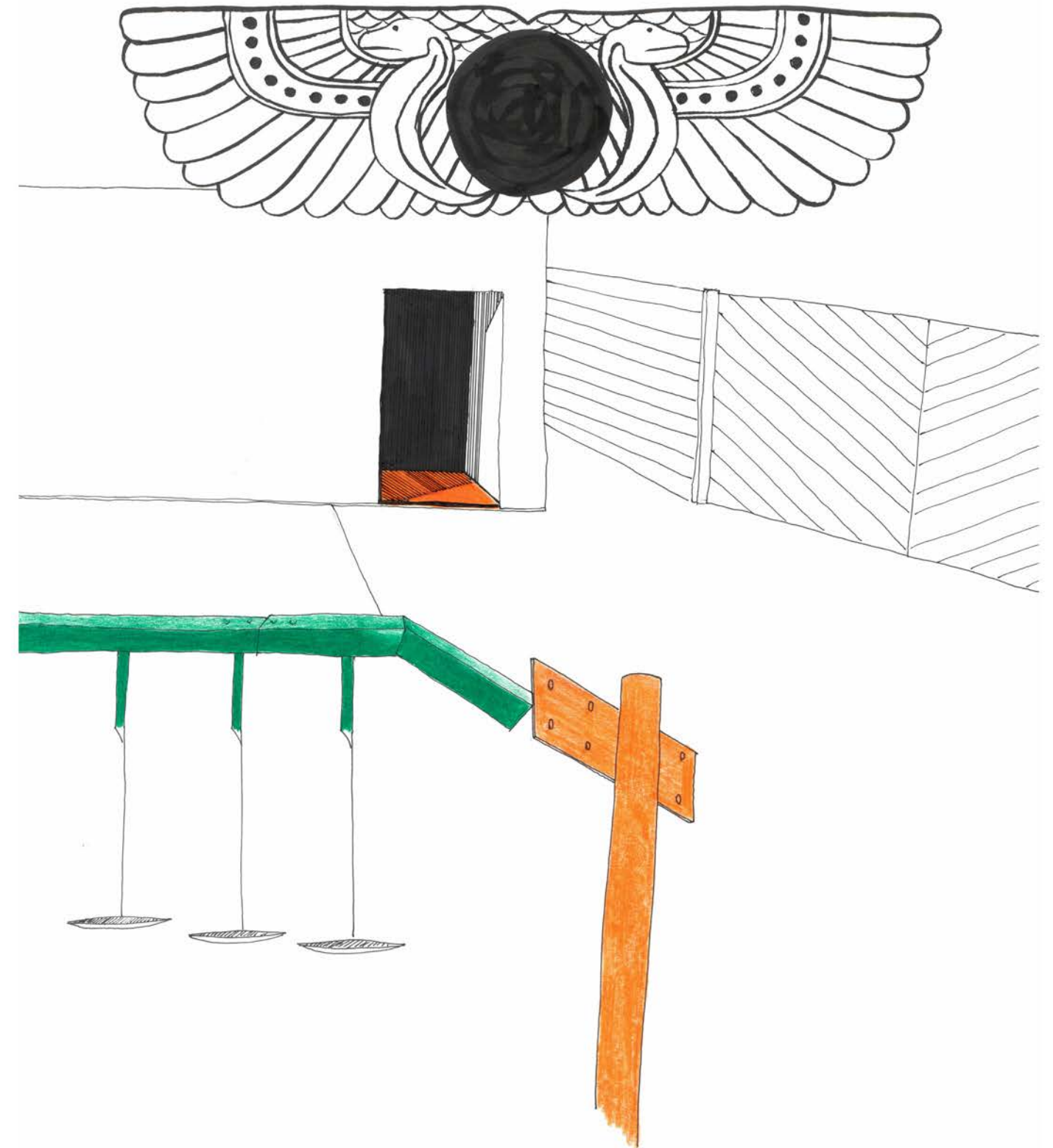

# Abysses

Some people think, that to evict demons, curses and death it needs dark rituals full of fire, blood and mantras.

They sacrifice frogs and rats and other creatures. They dance and murmur, they talk to earth and other elements.

Madness, delusion and illusion take possession of their soul.

Sometimes all this goes wrong and they become monsters, murderer, beasts.

All of this happened in this little tomb, in the dark grave. - Until someone came to cut life into the dead walls.

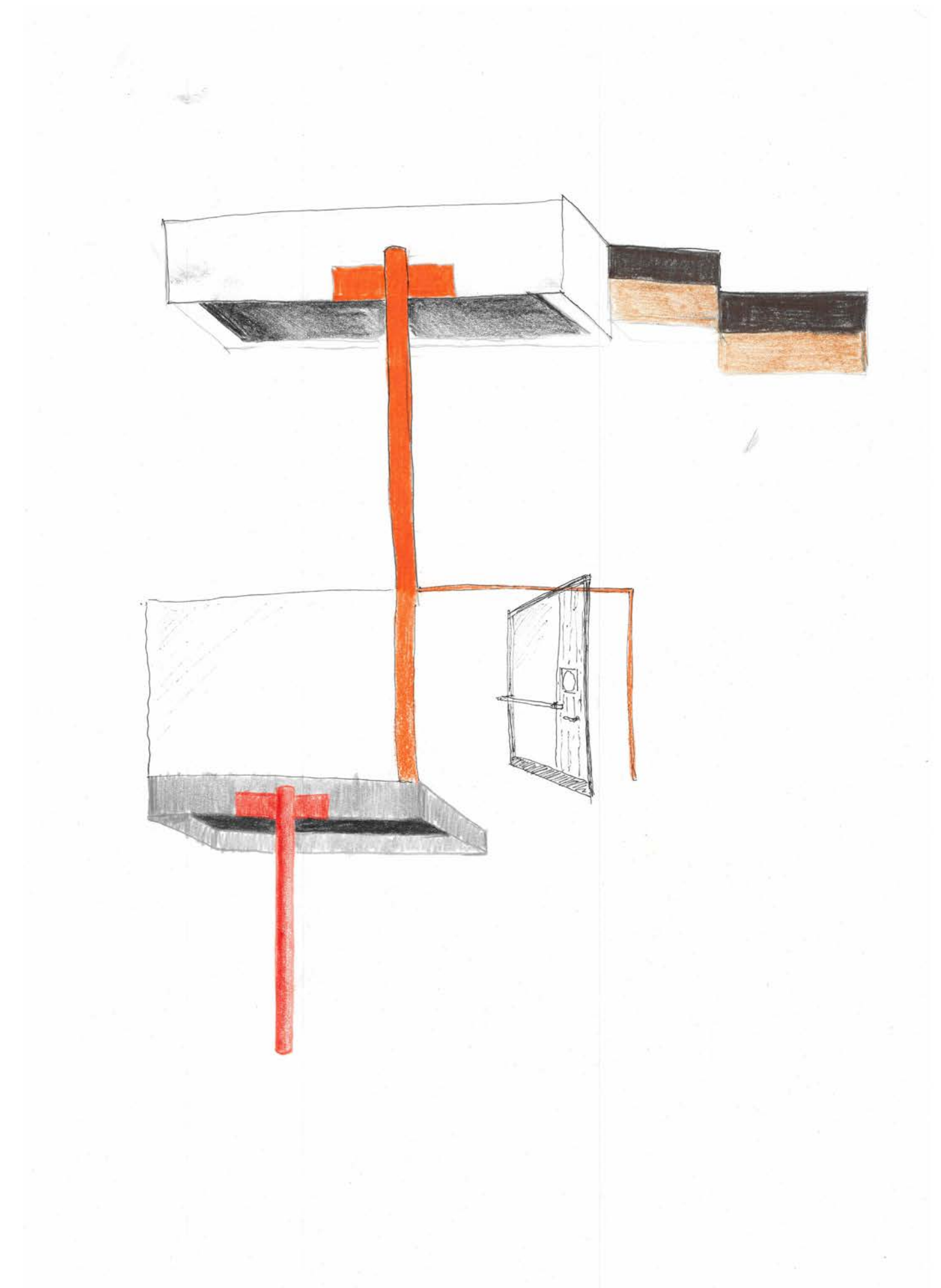

# Abysses

Some people think, that to evict demons, curses and death it needs dark rituals full of fire, blood and mantras.

They sacrifice frogs and rats and other creatures. They dance and murmur, they talk to earth and other elements.

Madness, delusion and illusion take possession of their soul.

Sometimes all this goes wrong and they become monsters, murderer, beasts.

All of this happened in this little tomb, in the dark grave. - Until someone came to cut life into the dead walls.

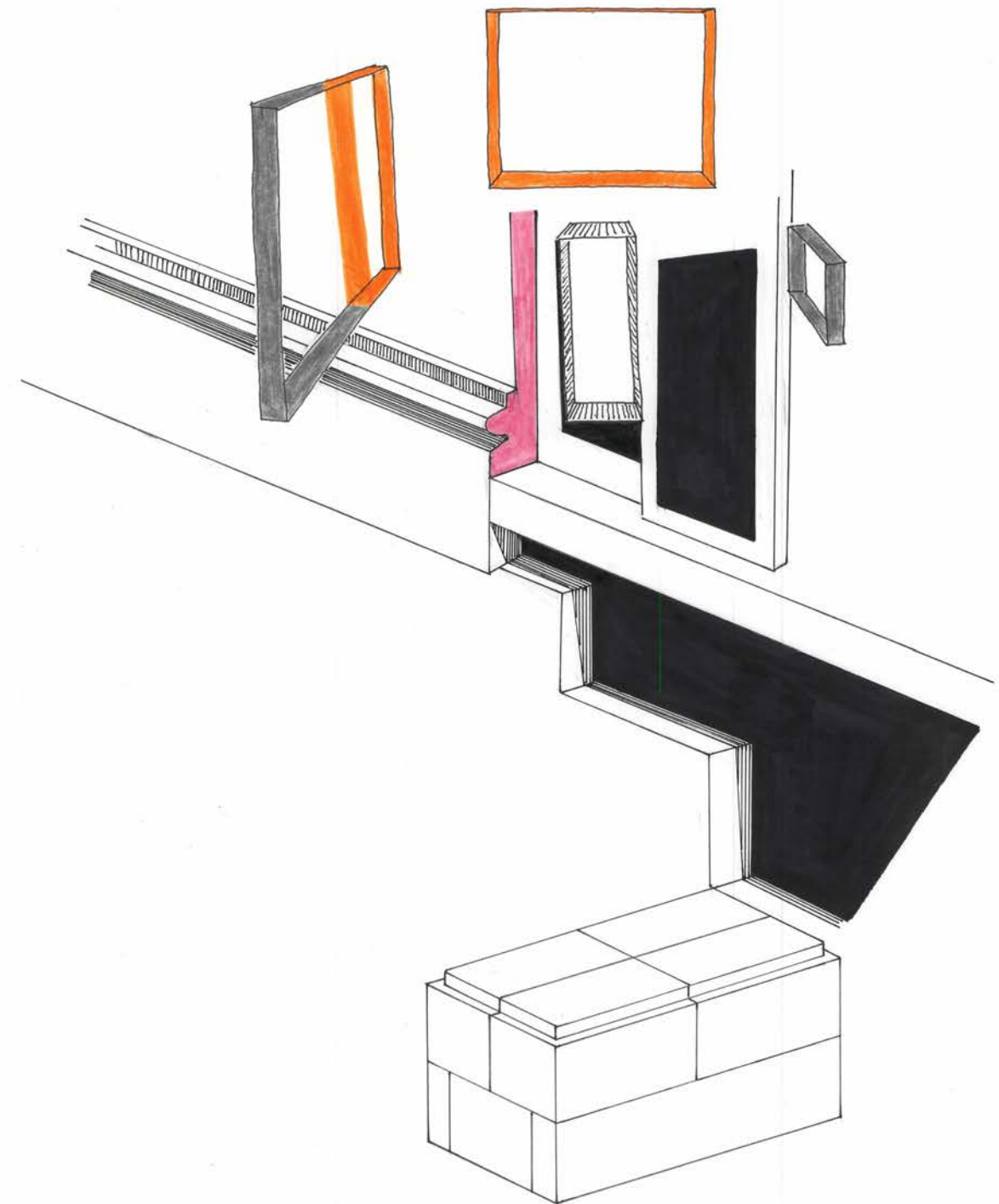

# Abyesses

Some people think, that to evict demons, curses and death it needs dark rituals full of fire, blood and mantras.

They sacrifice frogs and rats and other creatures. They dance and murmur, they talk to earth and other elements.

Madness, delusion and illusion take possession of their soul.

Sometimes all this goes wrong and they become monsters, murderer, beasts.

All of this happened in this little tomb, in the dark grave. - Until someone came to cut life into the dead walls.

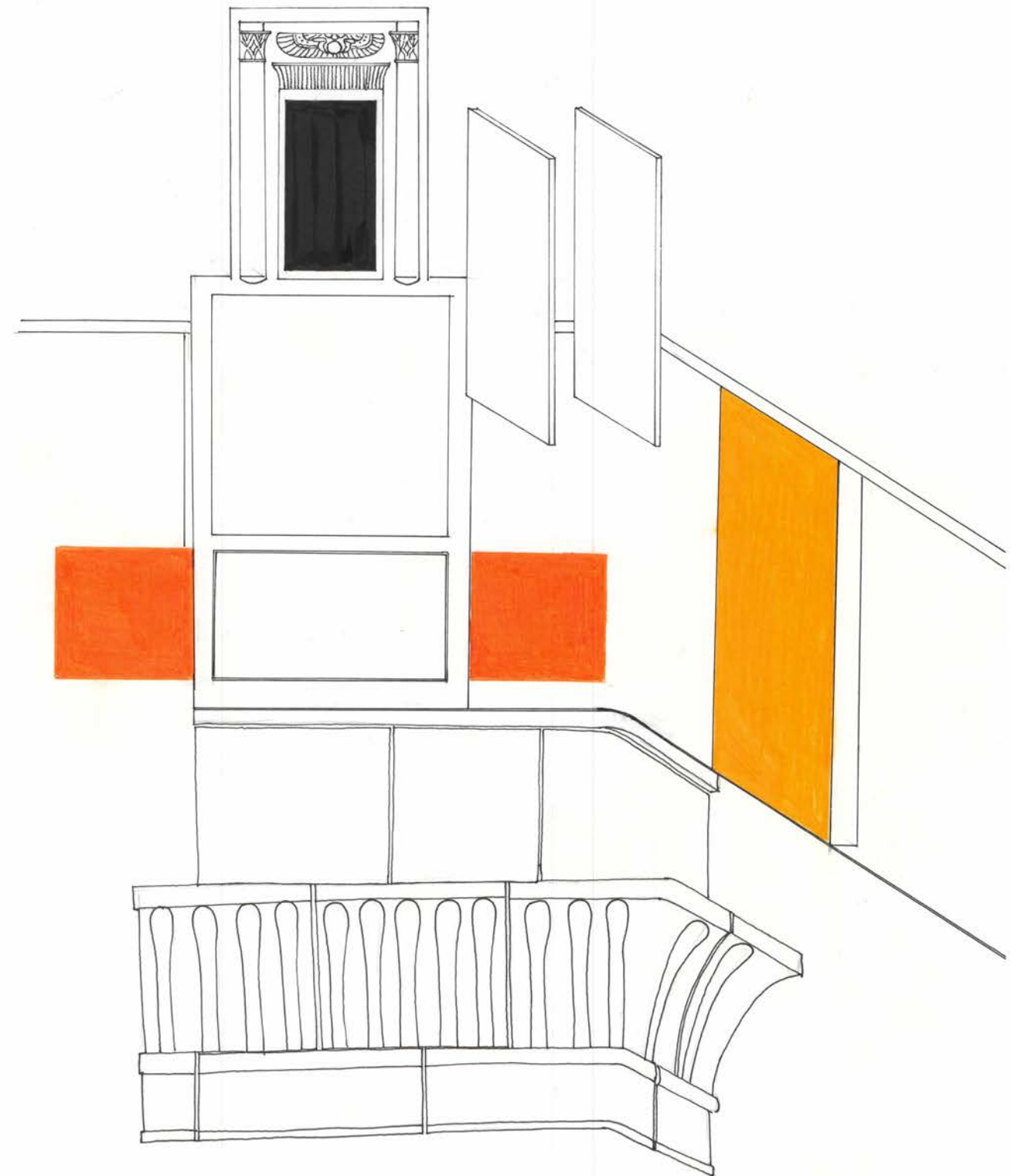

# Abysses

Some people think, that to evict demons, curses and death it needs dark rituals full of fire, blood and mantras.

They sacrifice frogs and rats and other creatures. They dance and murmur, they talk to earth and other elements.

Madness, delusion and illusion take possession of their soul.

Sometimes all this goes wrong and they become monsters, murderer, beasts.

All of this happened in this little tomb, in the dark grave. - Until someone came to cut life into the dead walls.

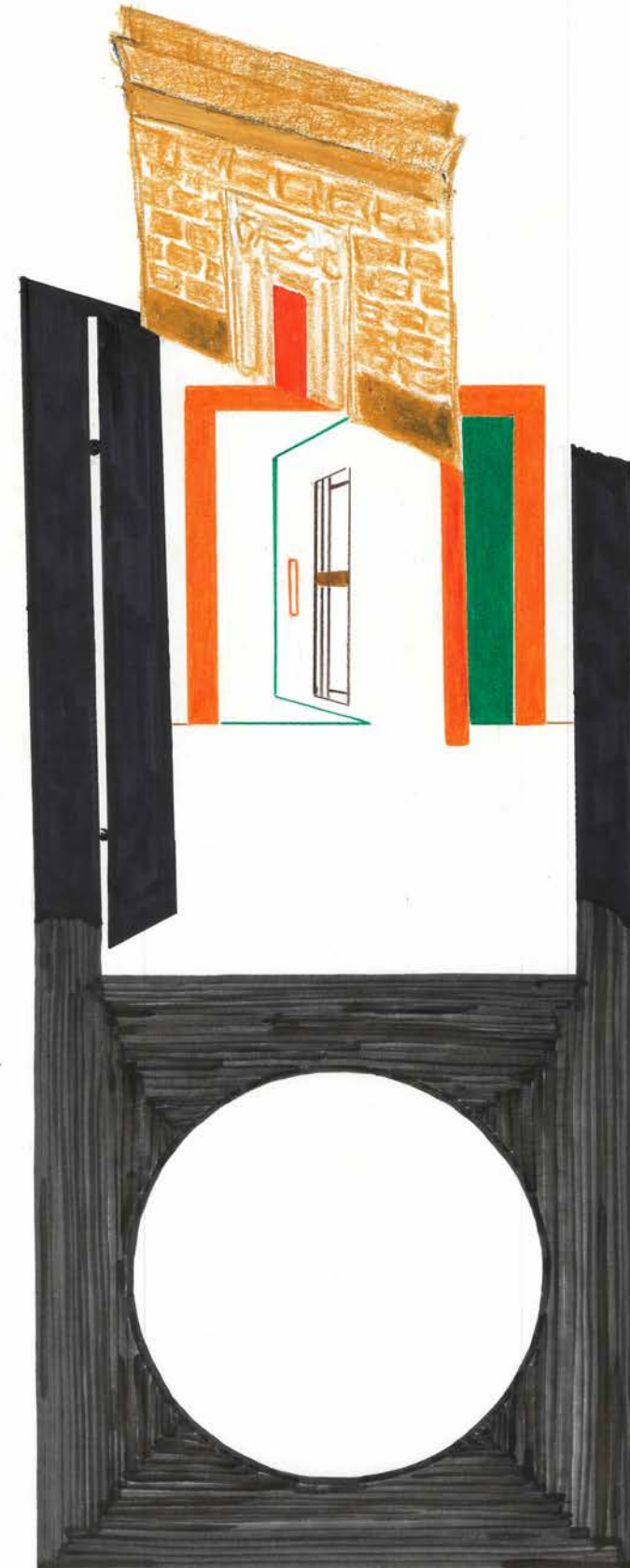







Chapter 1    Wolfers House (BE) / Van der Ploeg House (CH) / Sphinx Head Tomb (US)



Heuer, Henrike / Weber, Carmino / Vonder Mühl, Tobias









# Movement 2

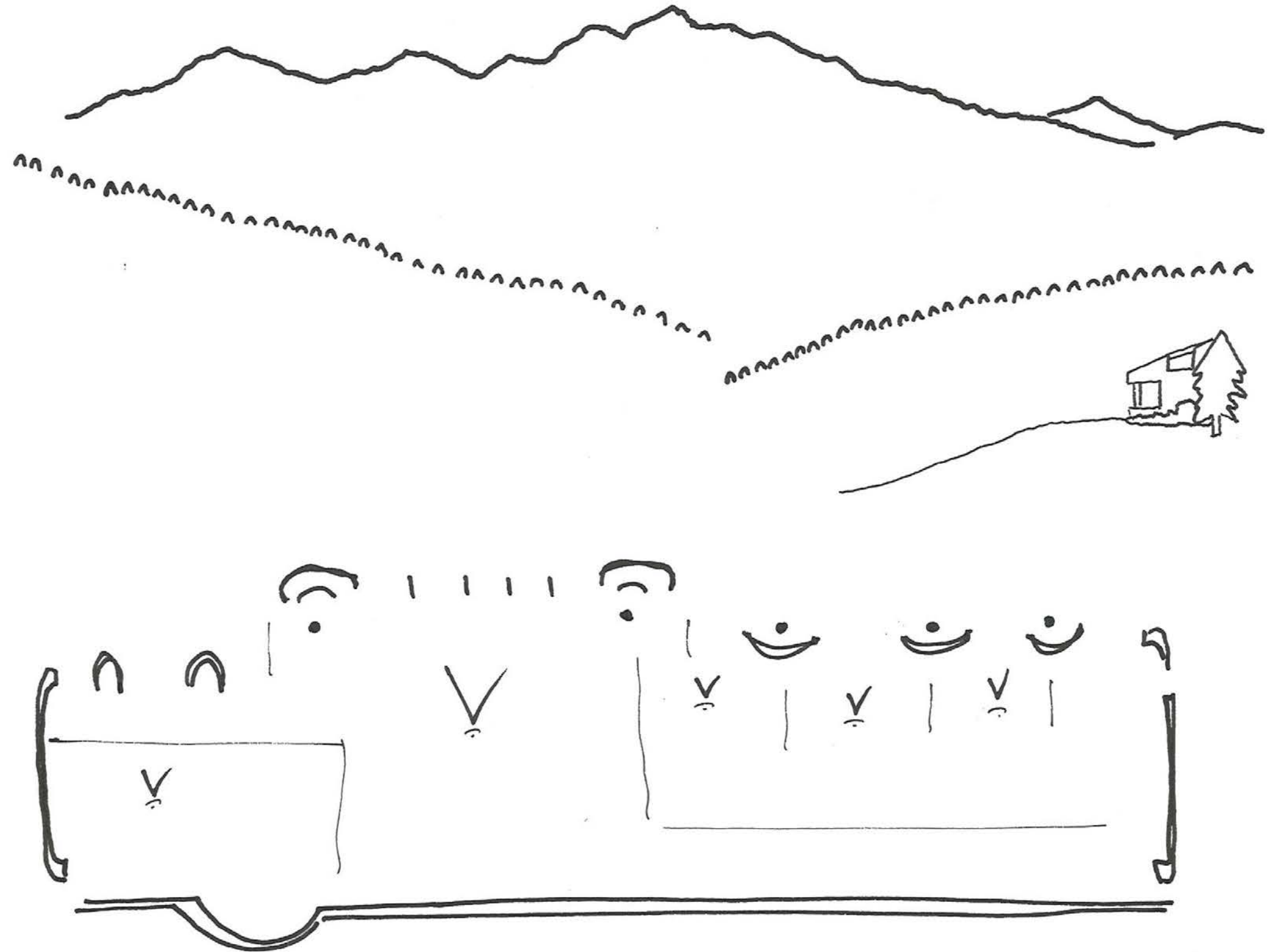







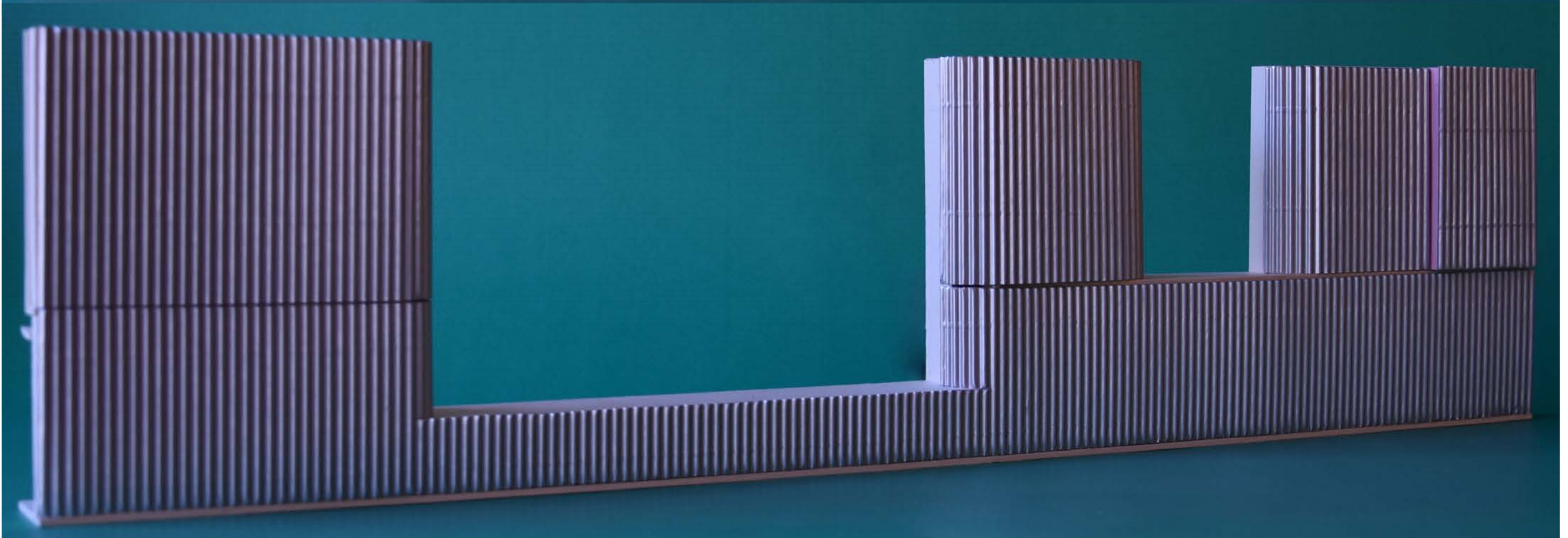
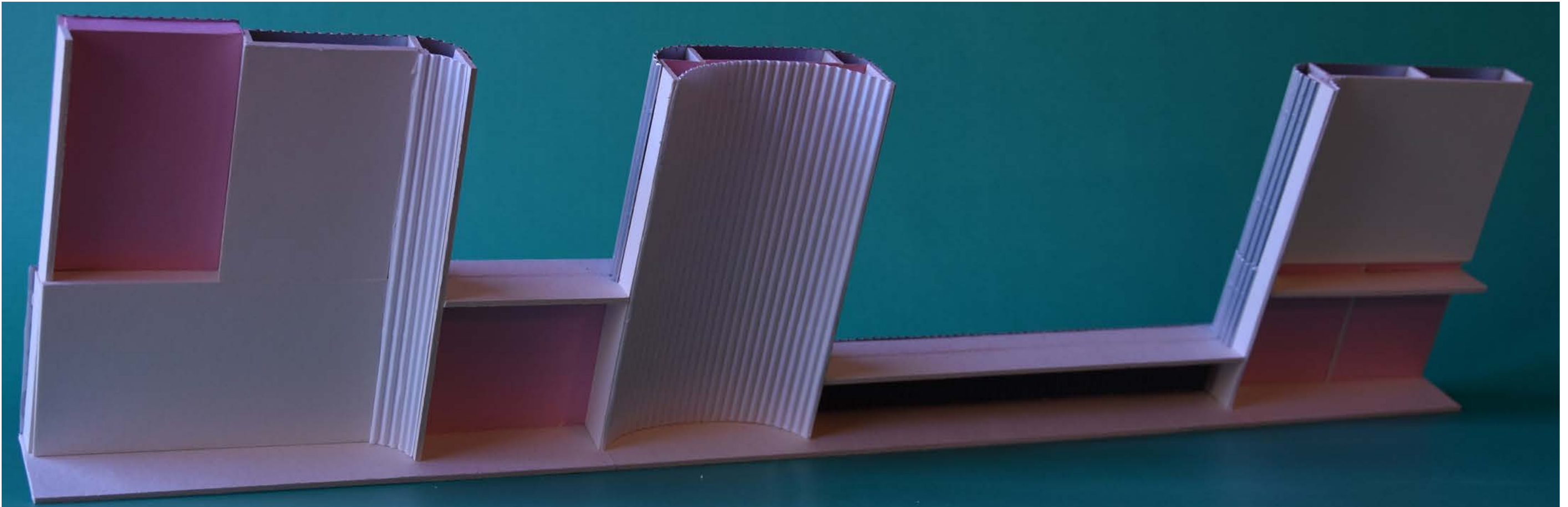

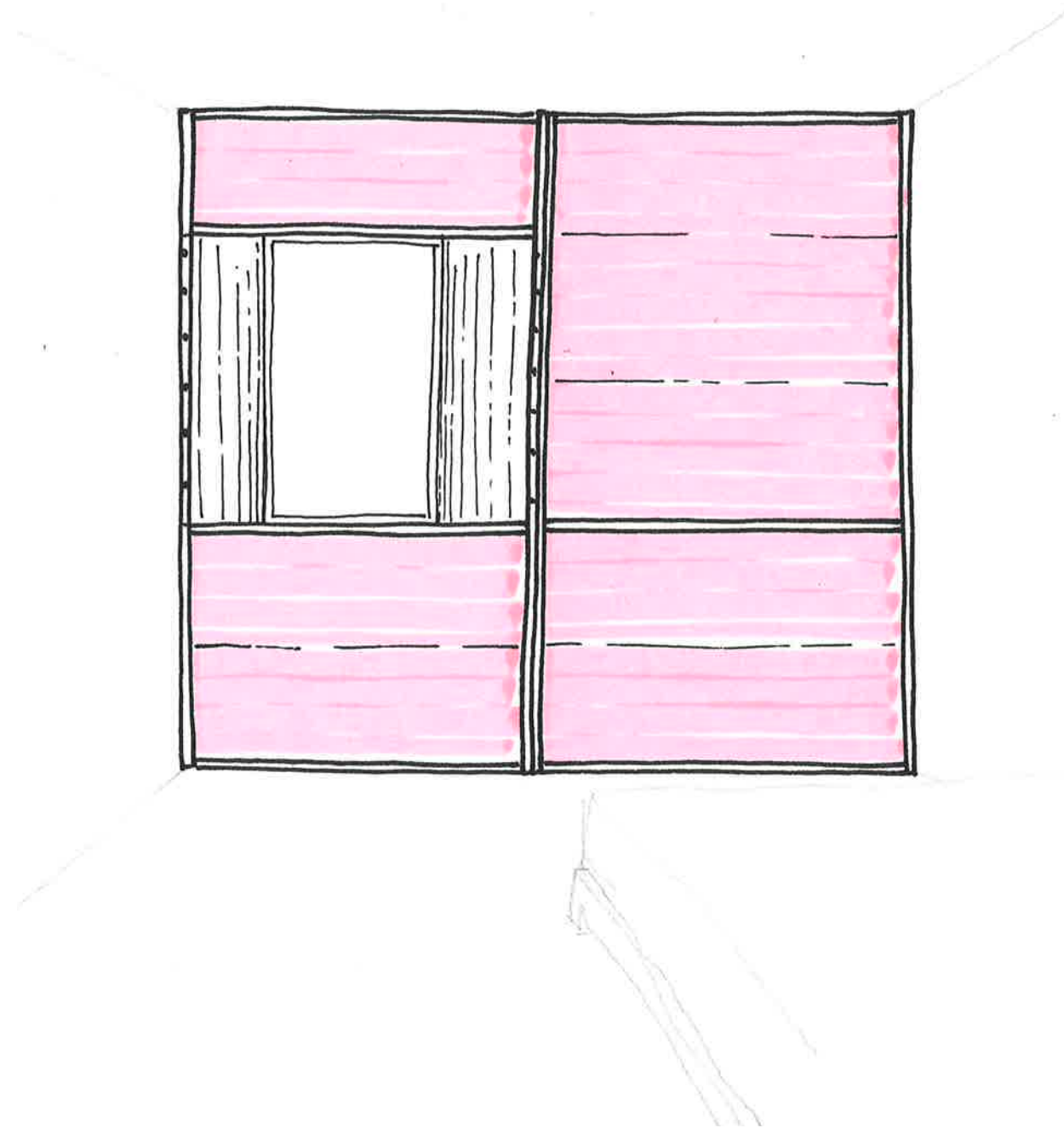

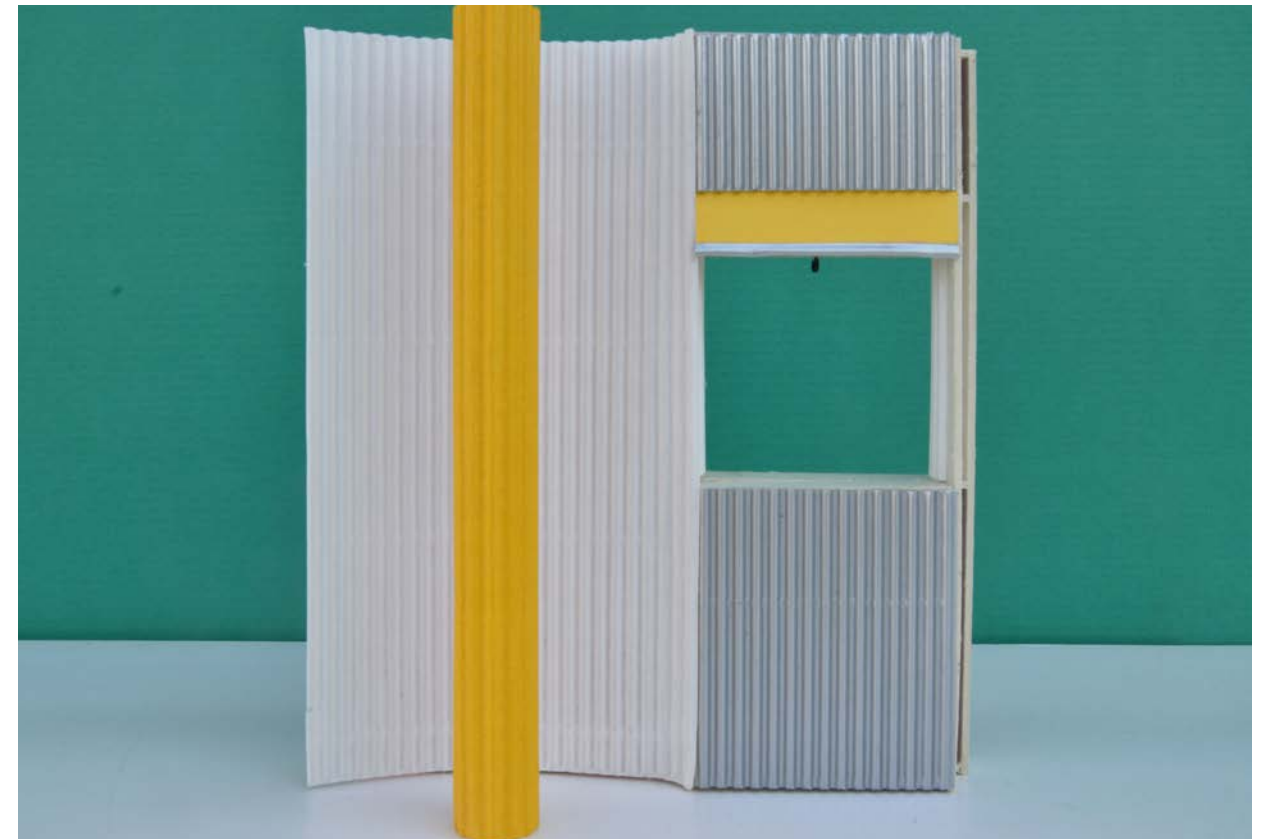
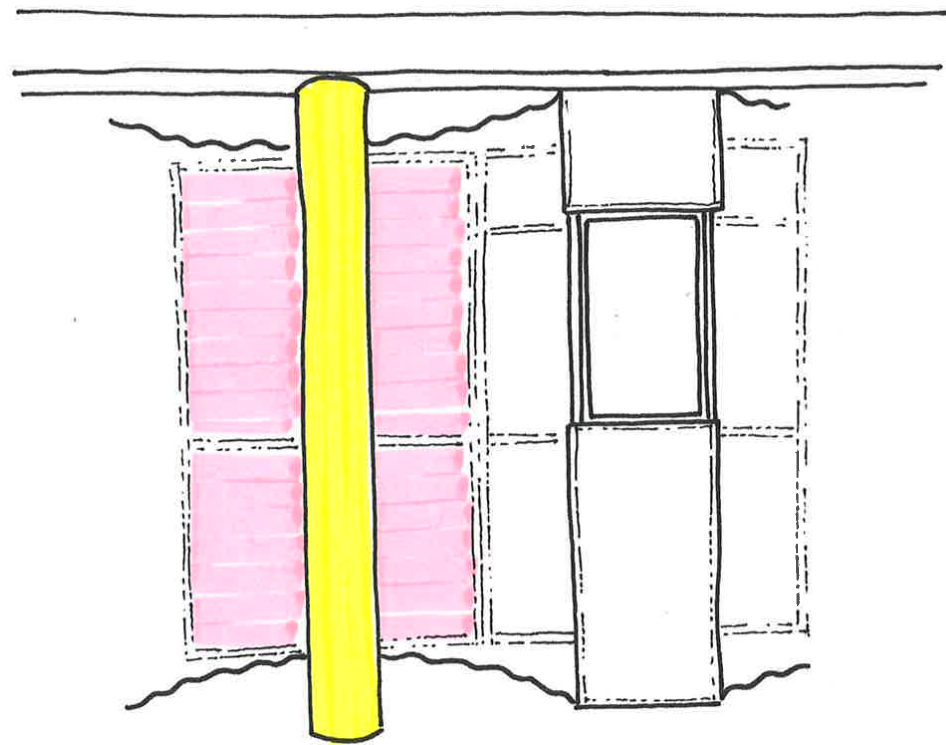

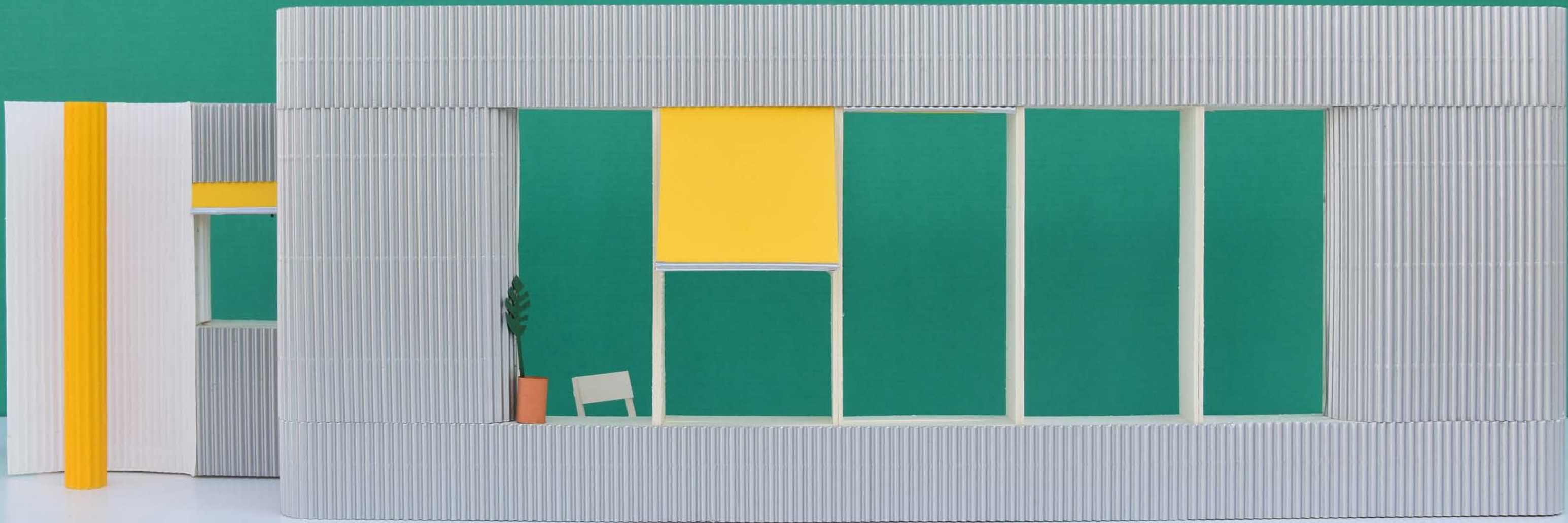

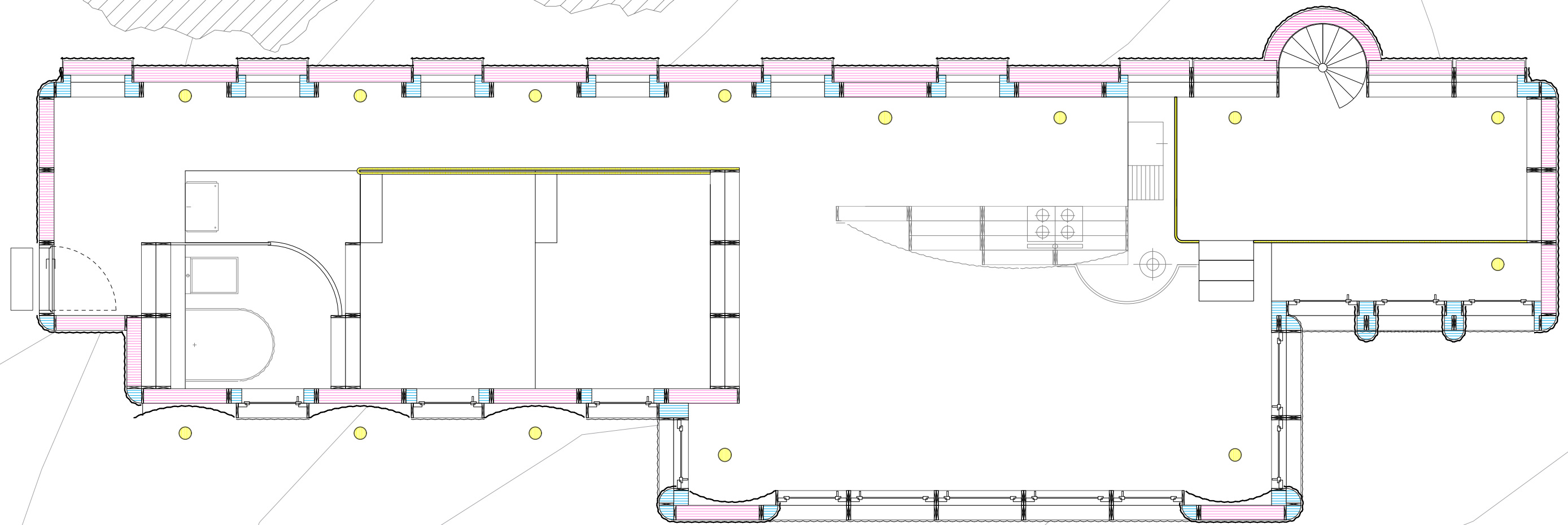

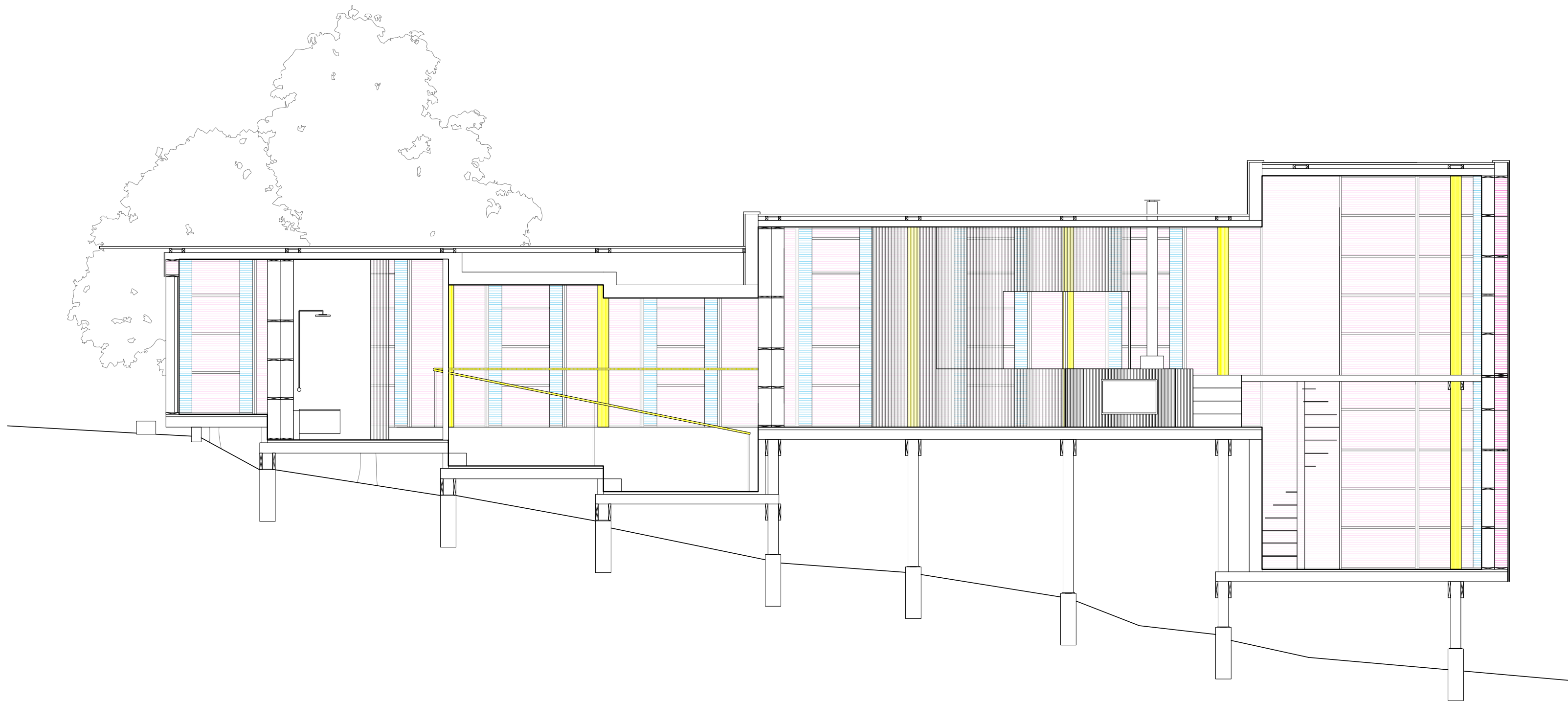

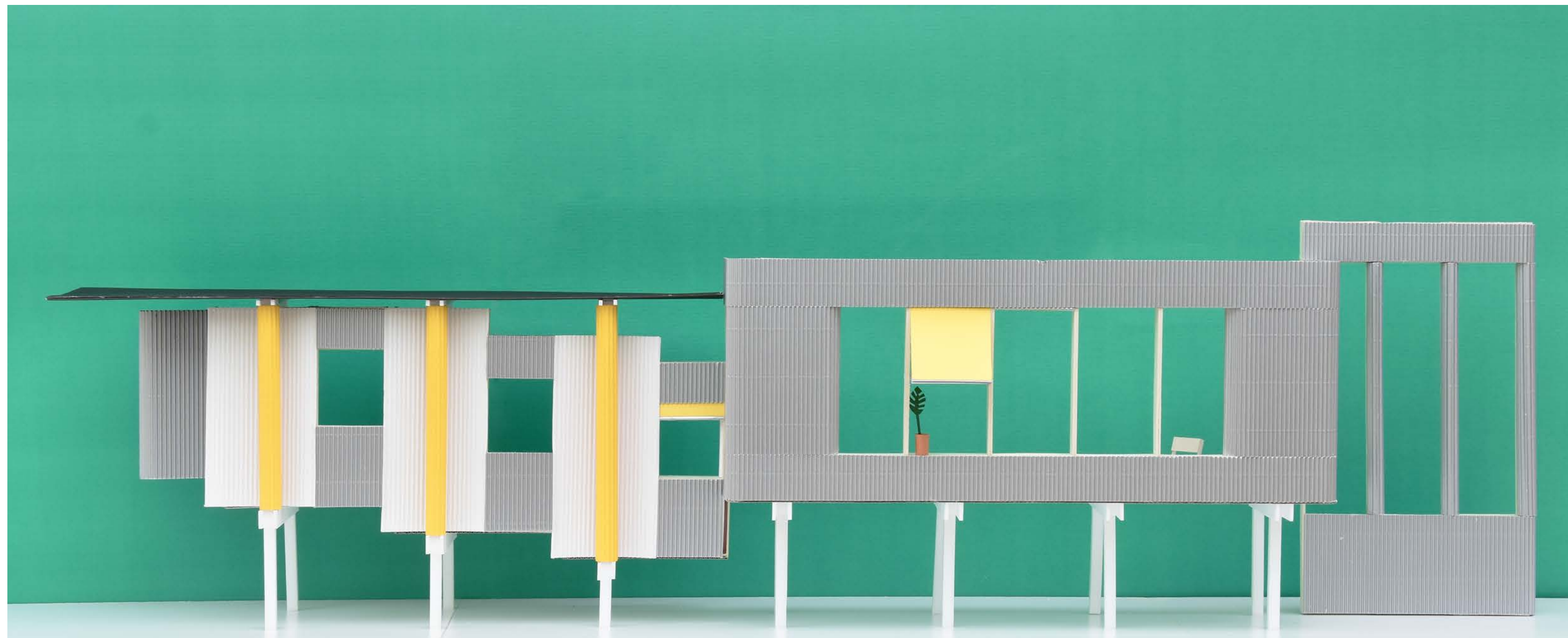



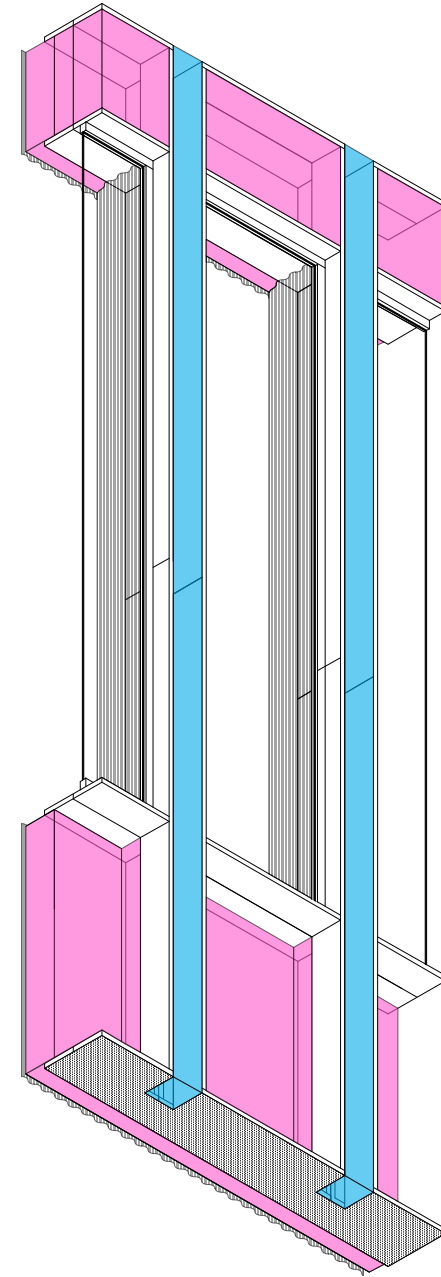
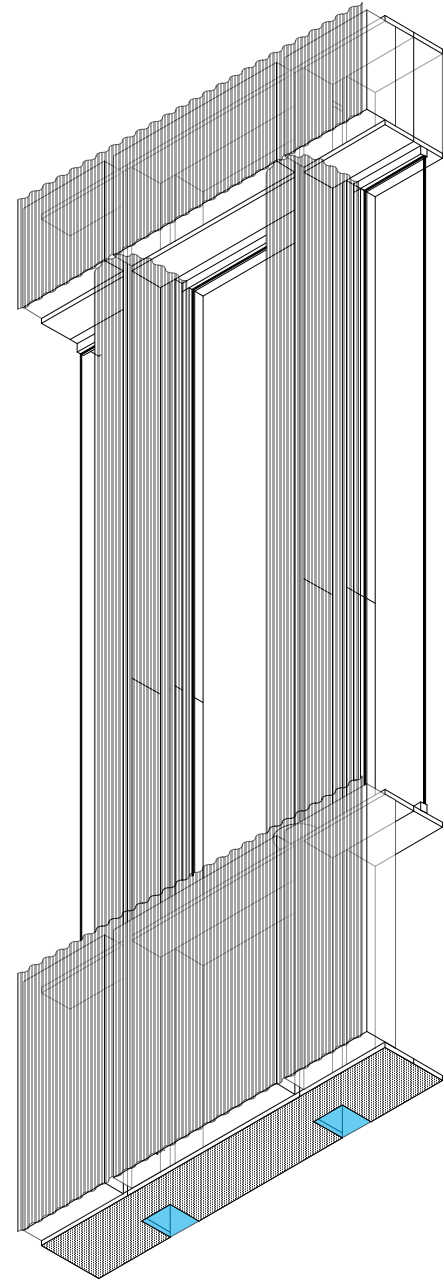
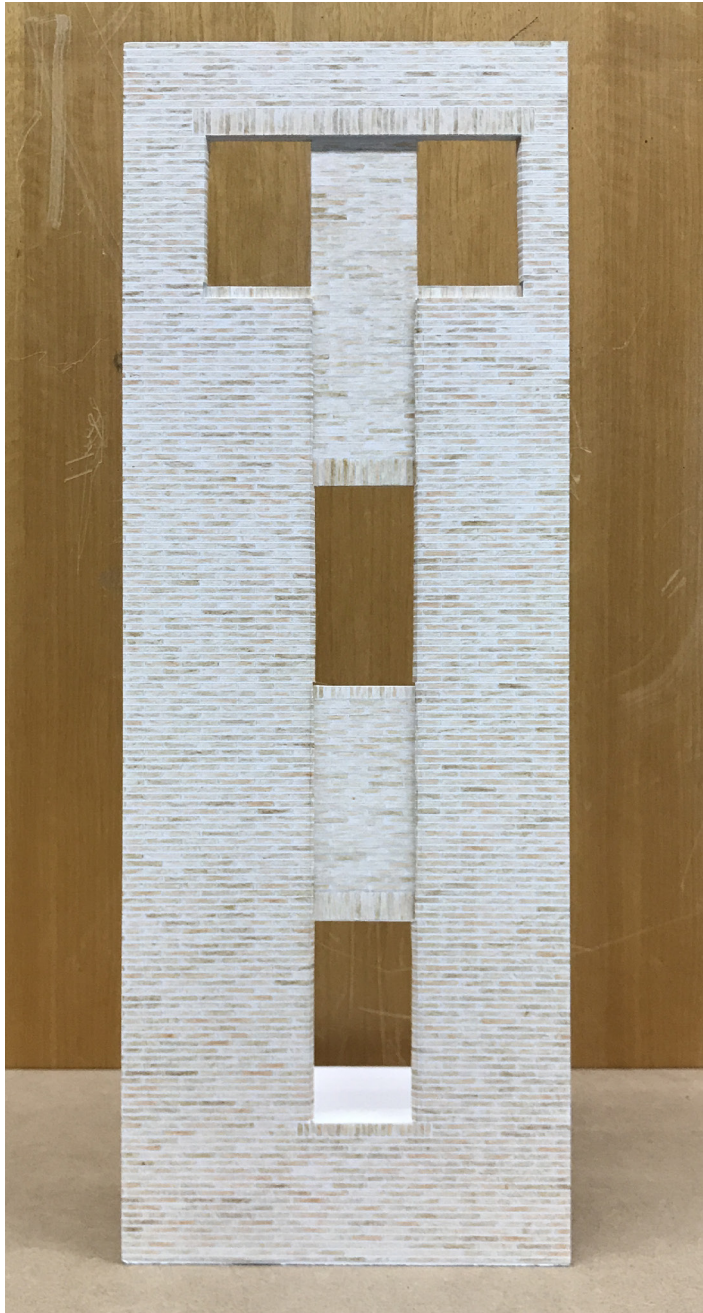

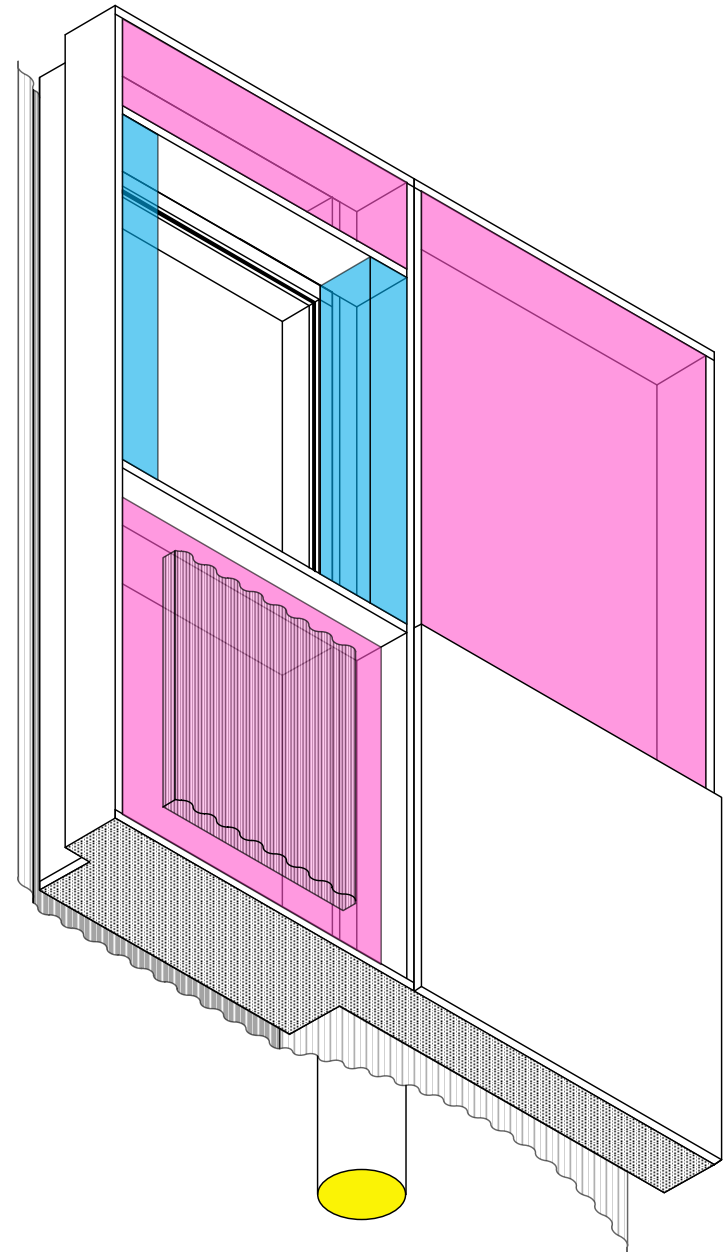
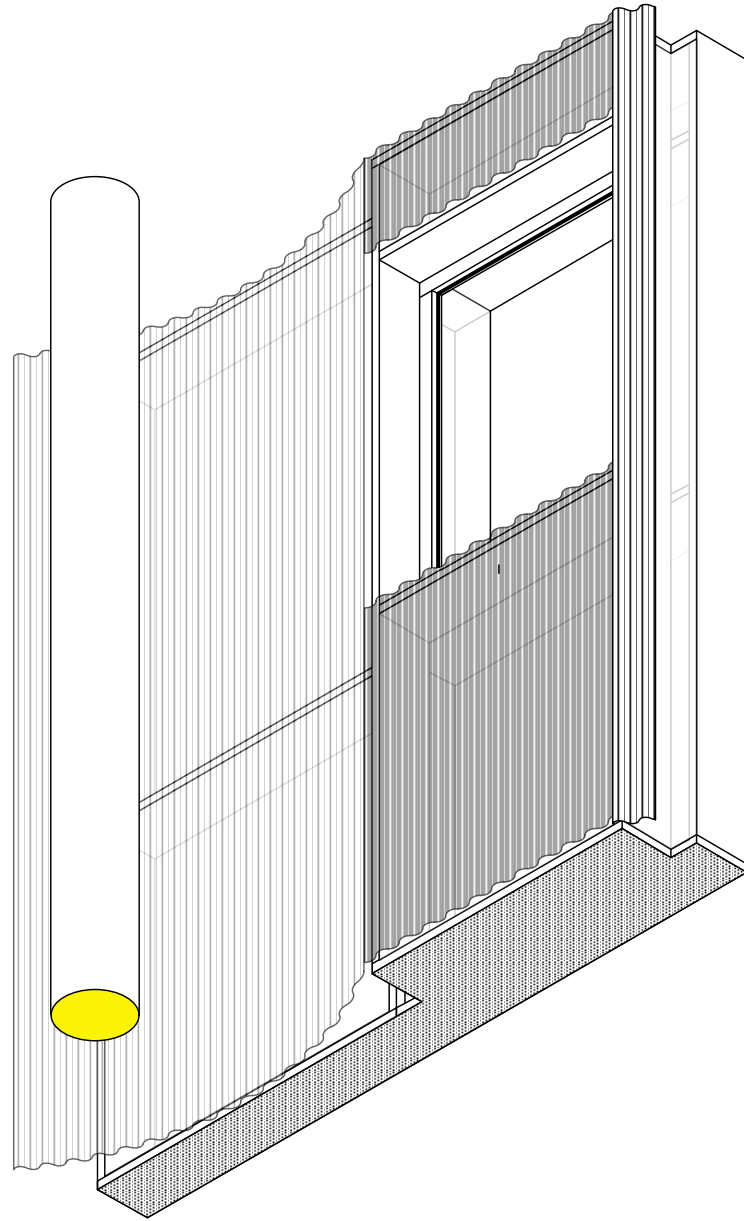

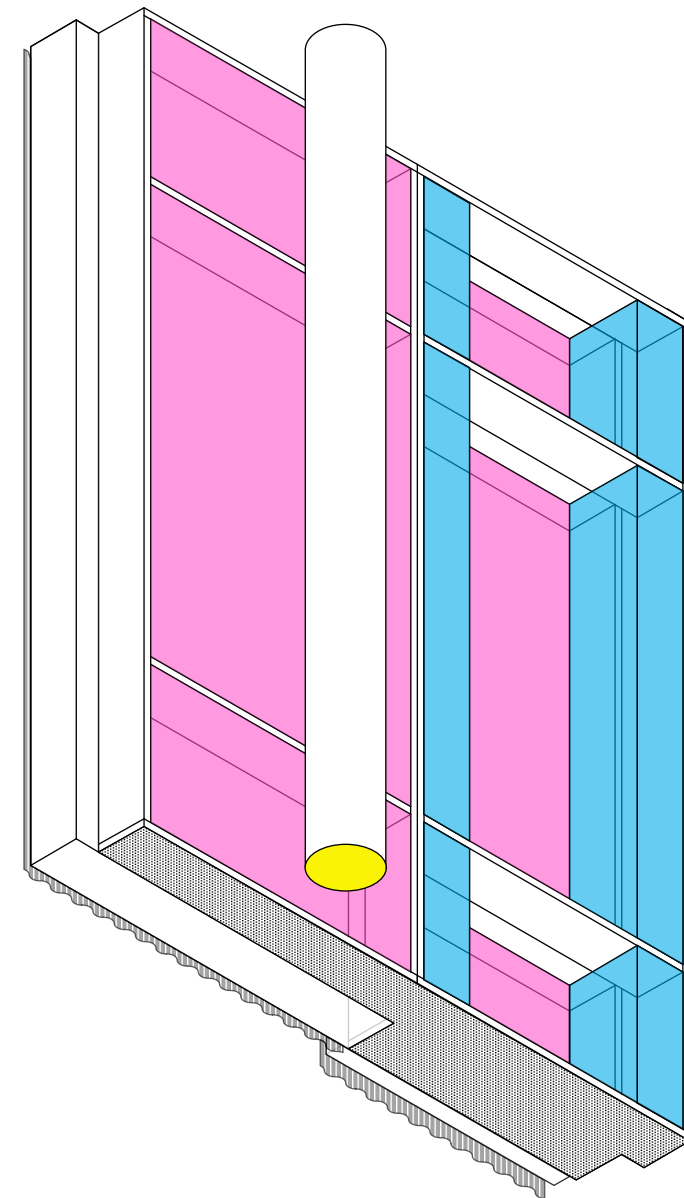
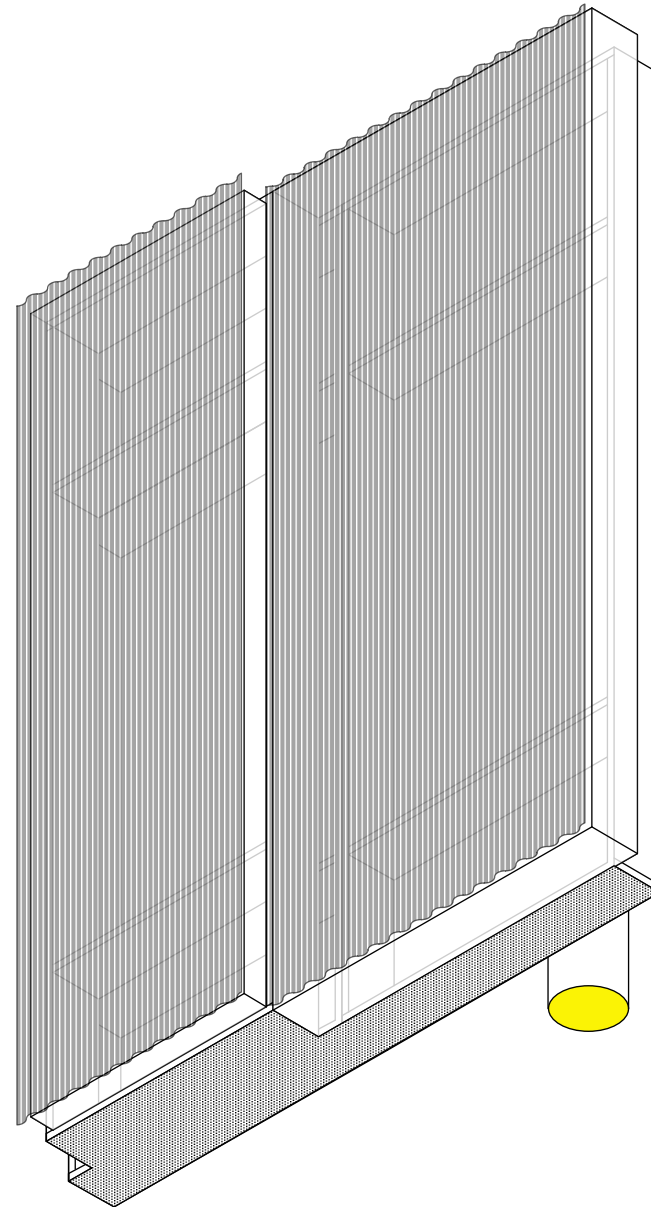

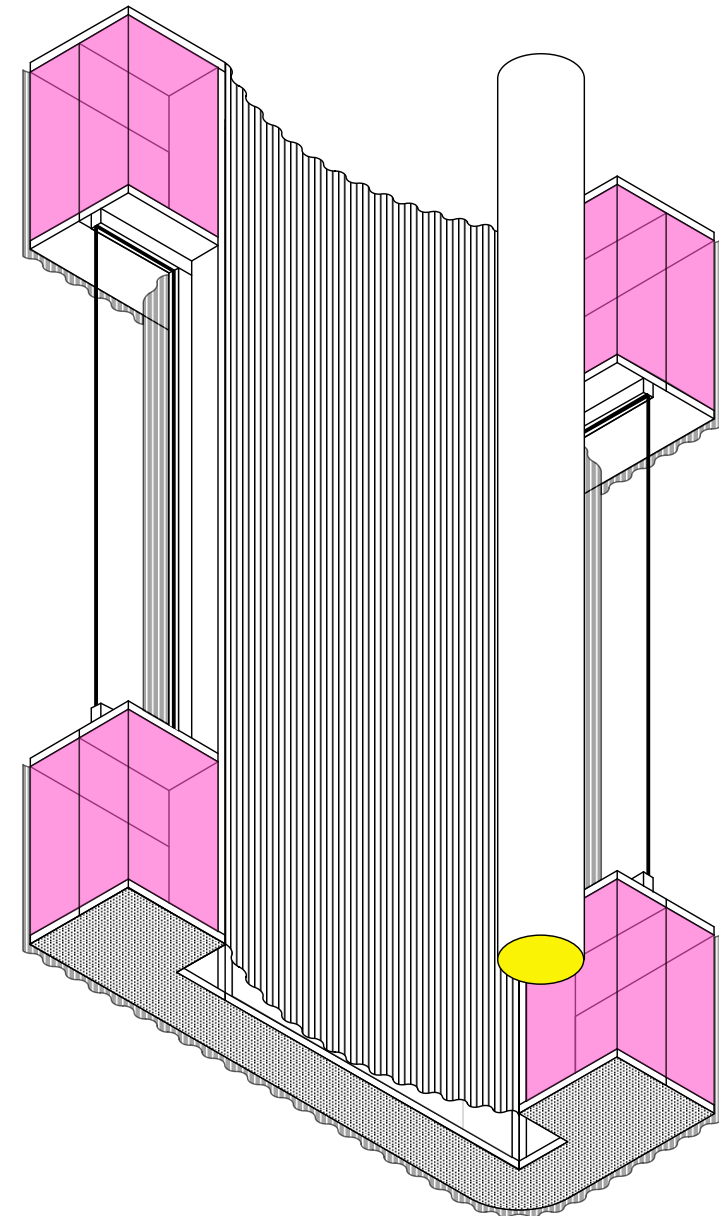
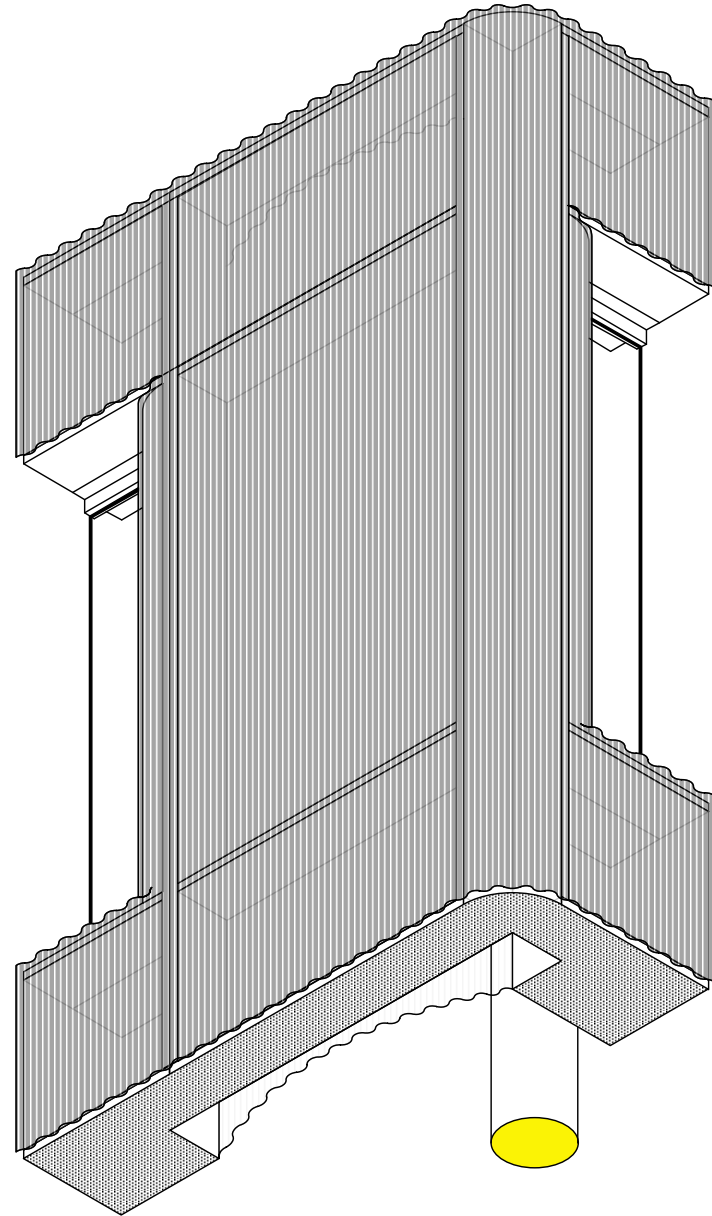



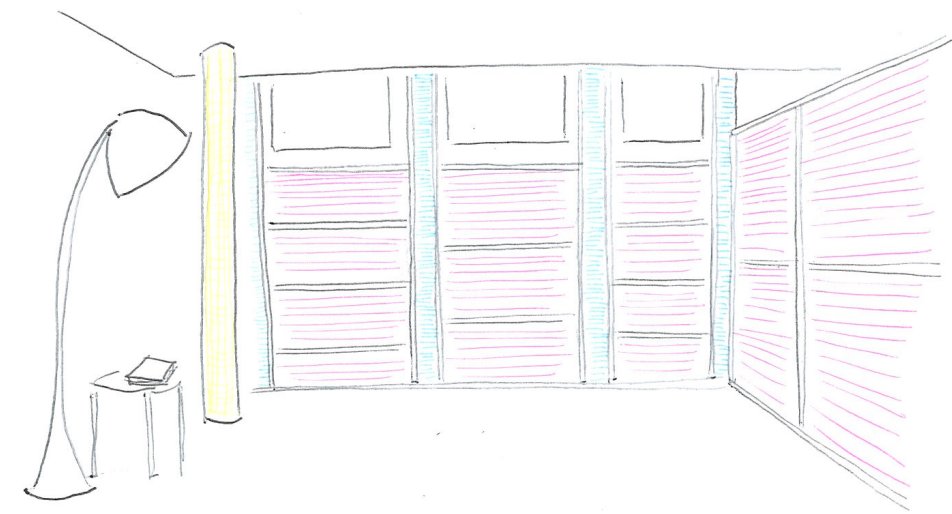



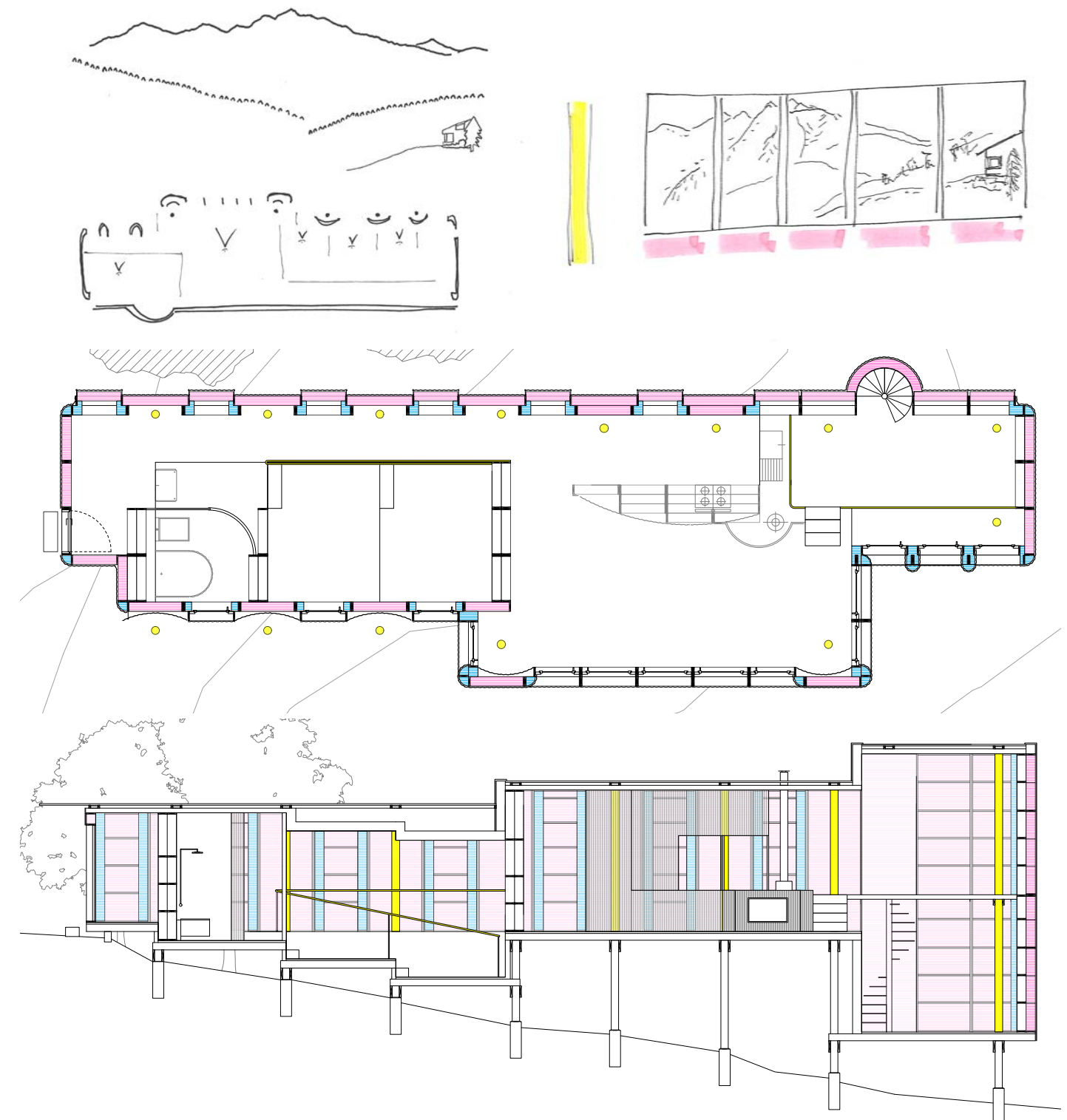
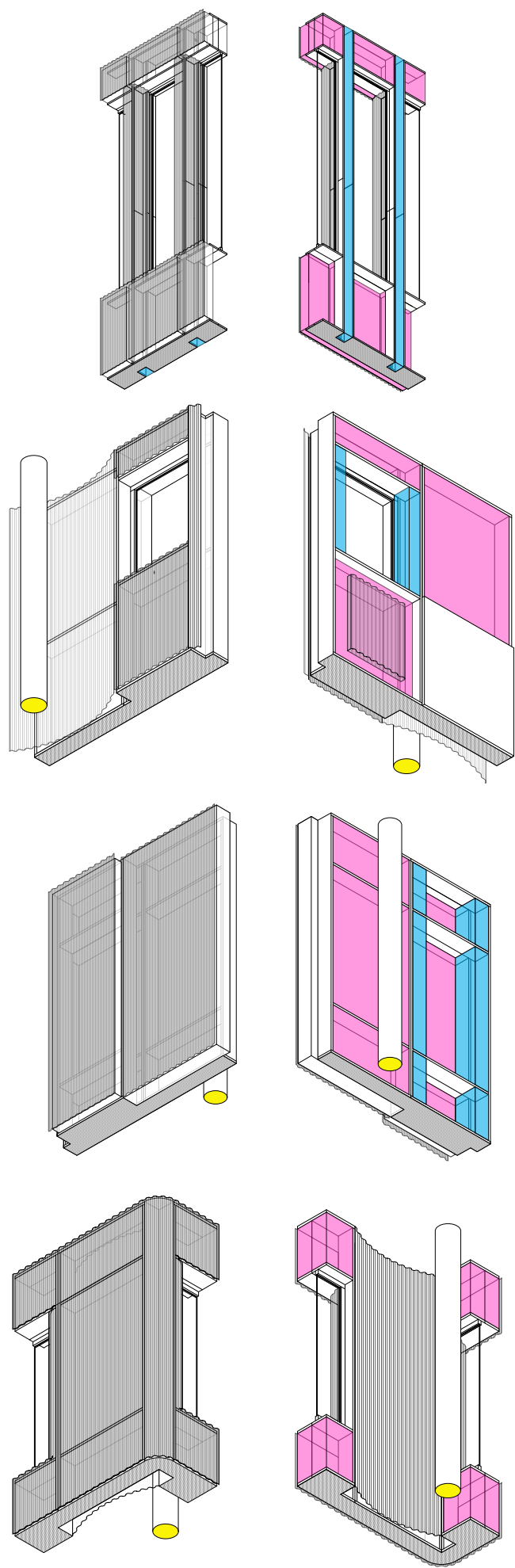



# Movement 2



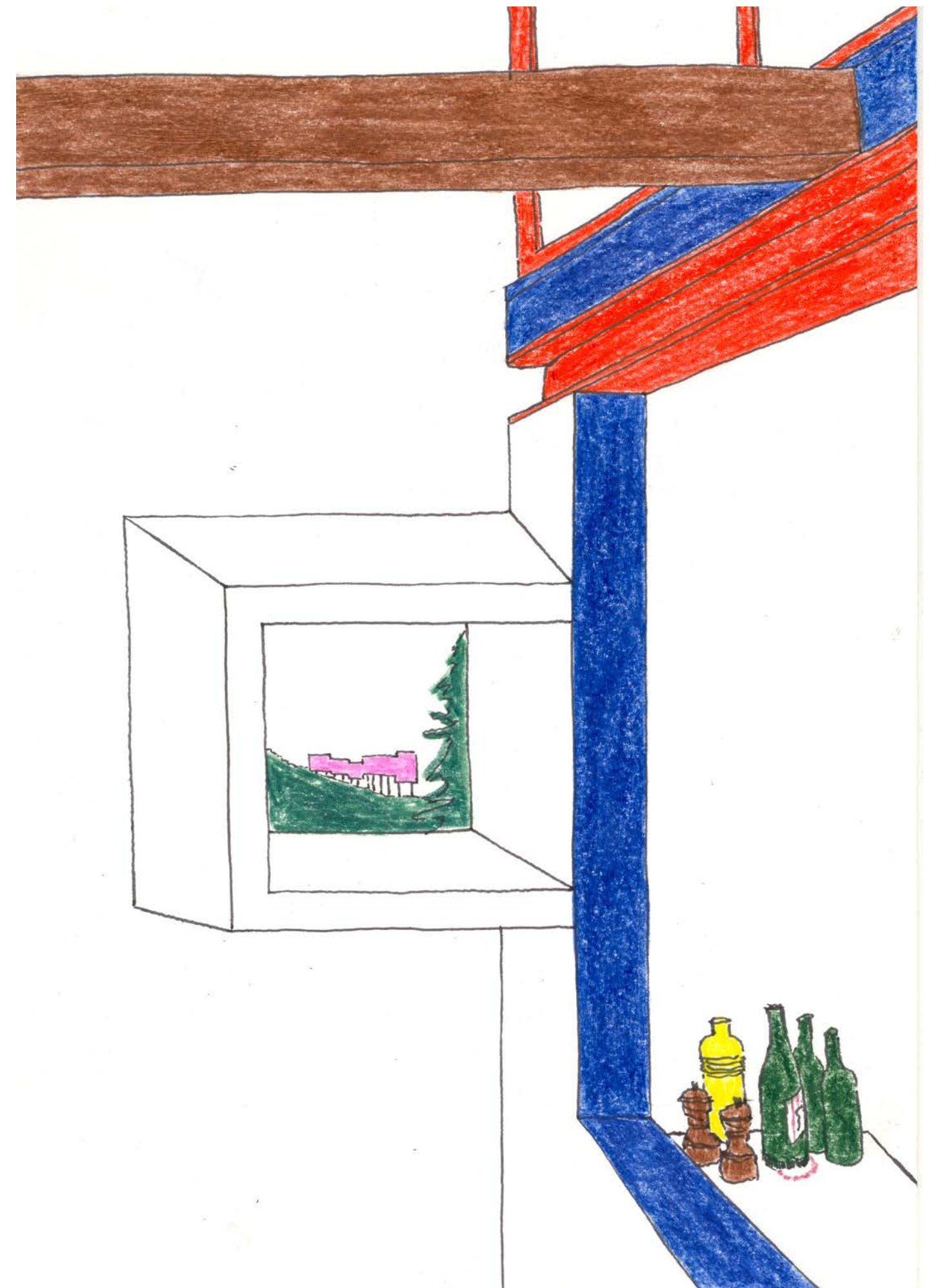
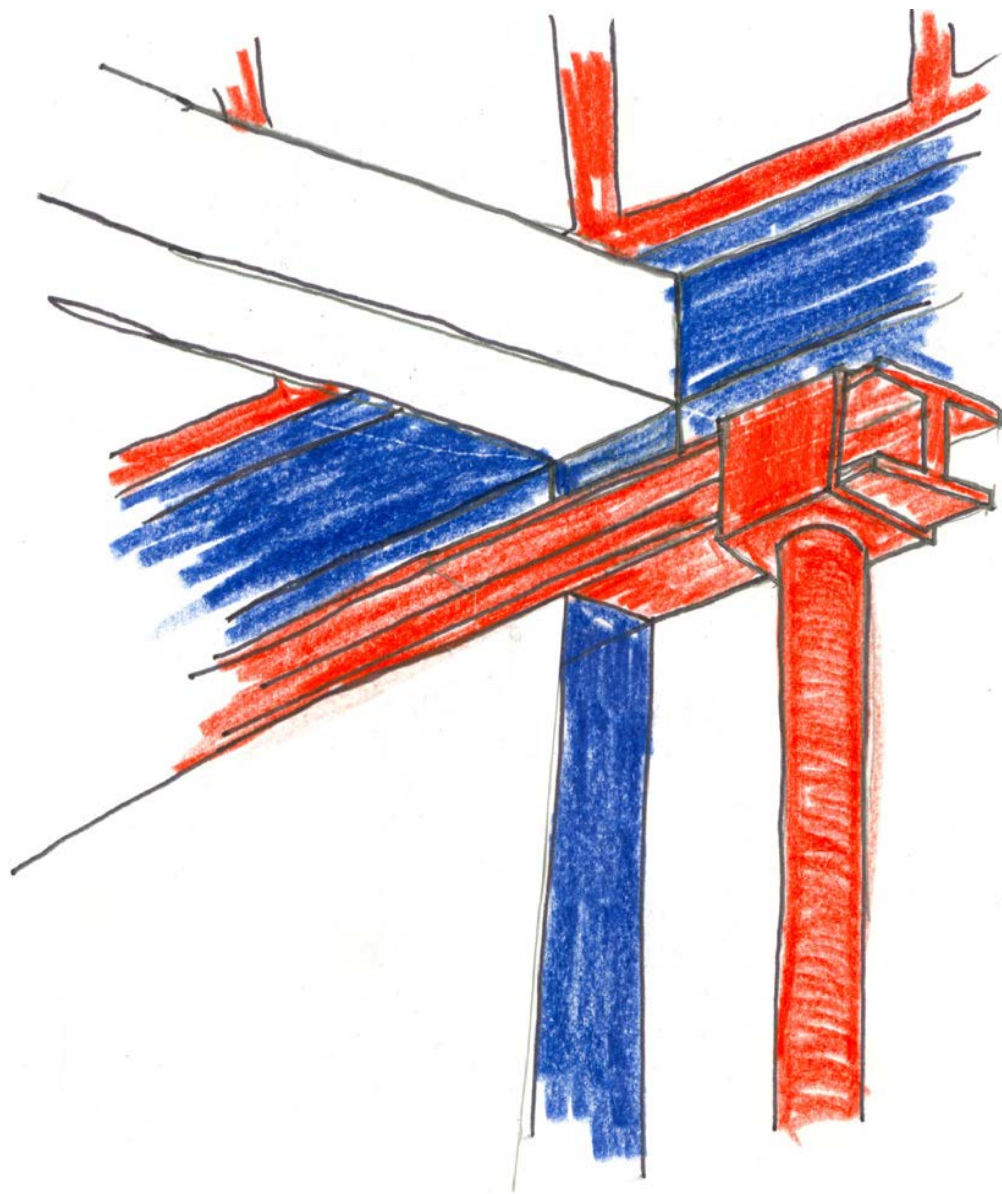

## chapter of novel

On a chilly winters day  
upon a house he came  
that in a snowy cover lay  
almost hidden, in the plain

with thick stone walls enclosing  
a seemingly roofless house  
but for the smoke above the  
chimney brooding  
promising a refuge, safe and sound

but as the door behind him closed  
he didn't see what he'd supposed  
instead the plain façade revealed  
a face more complex than proposed

the cornered white walls were slender  
and instead of ceilings he could see  
the wooden beams that held together  
the floors so easily

through deep windows flowed bright  
the outsides snowy light  
and into every room he went  
he was followed by a coffee scent

so in the house, he stayed a while, to dwell  
comforted, and hidden well



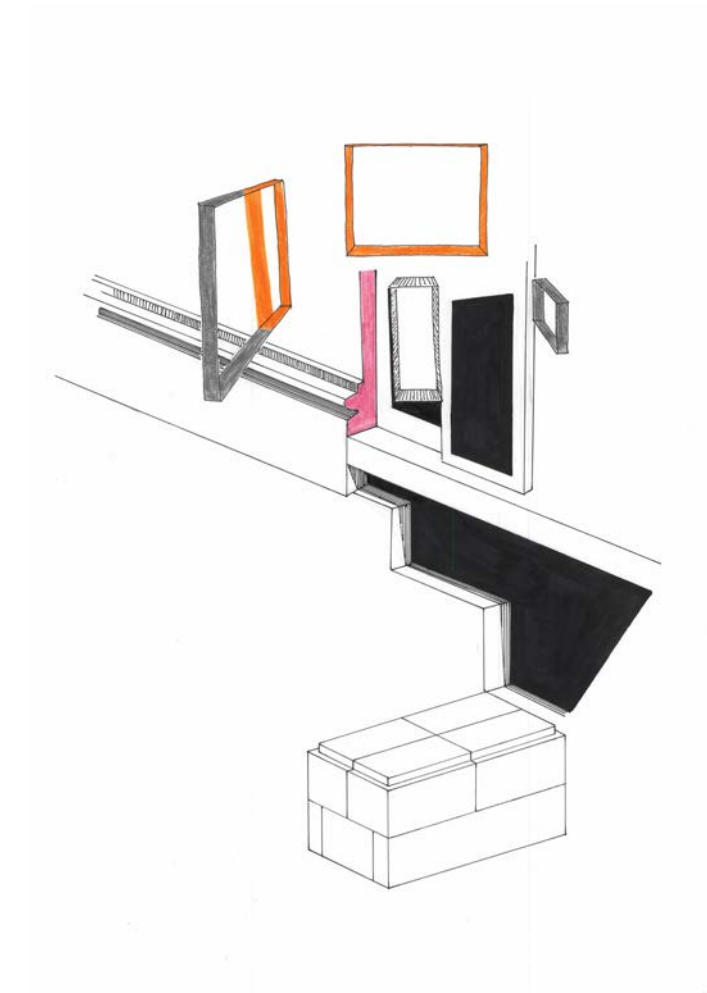

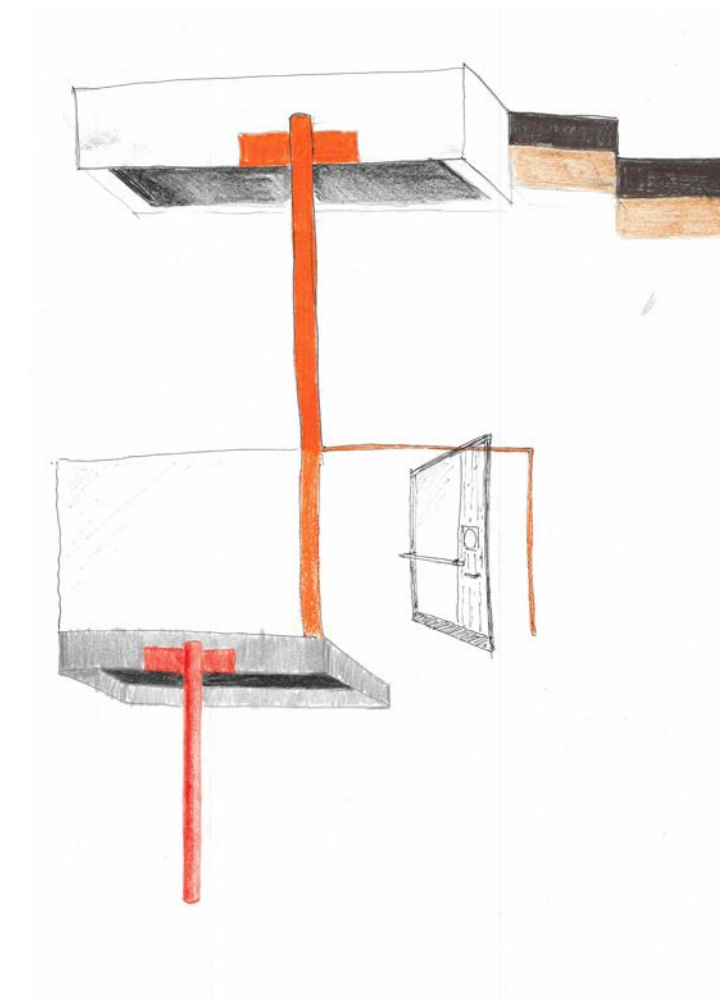
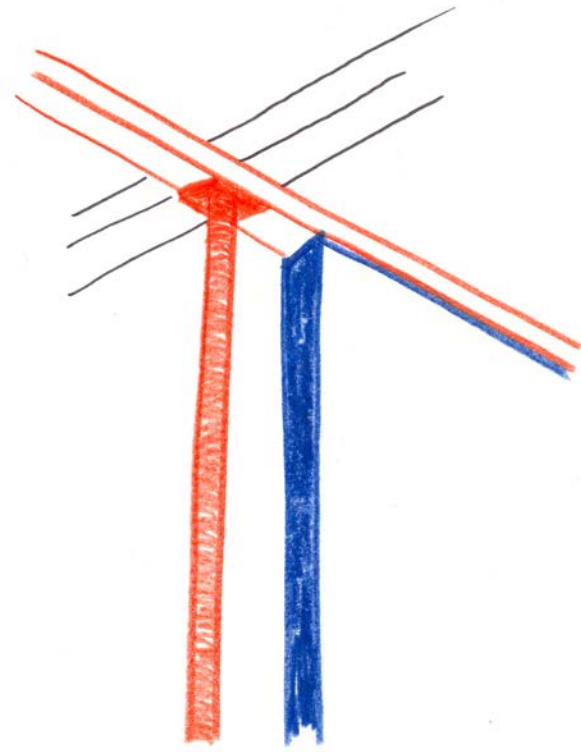

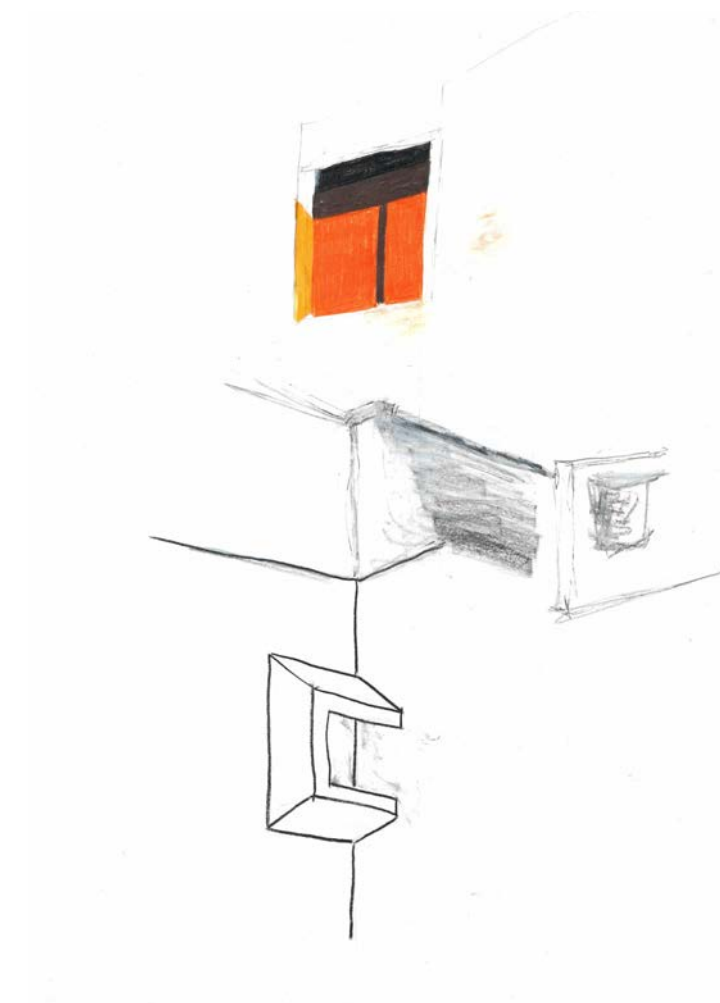
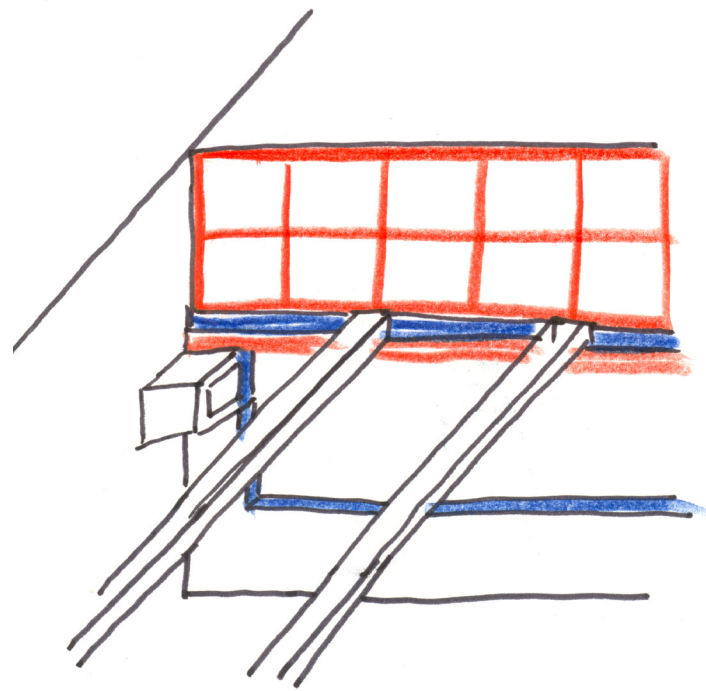

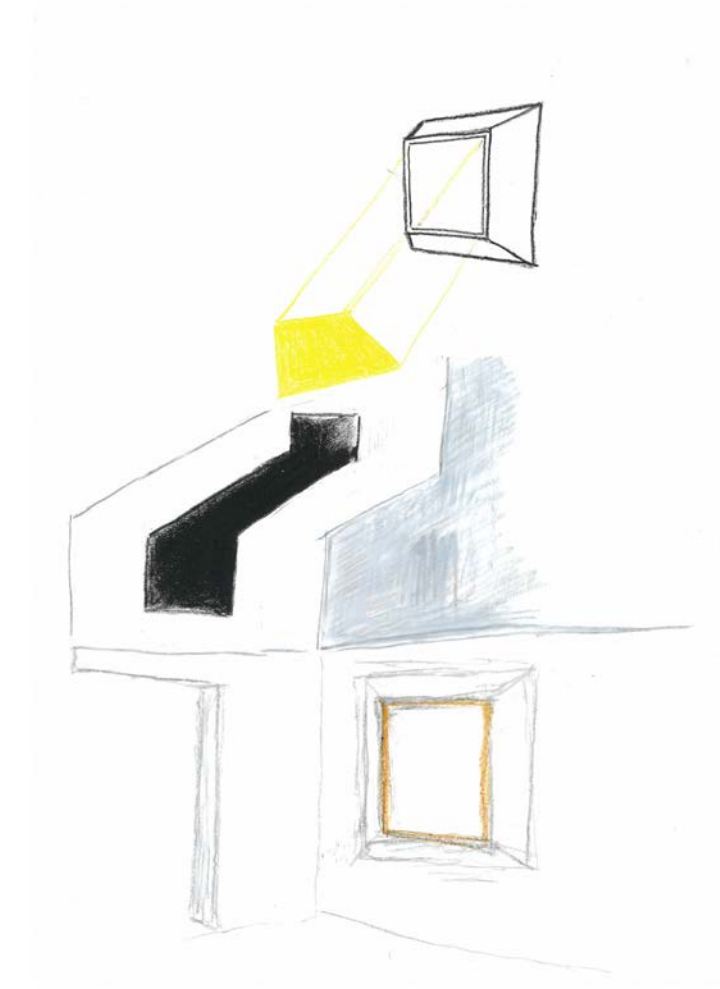
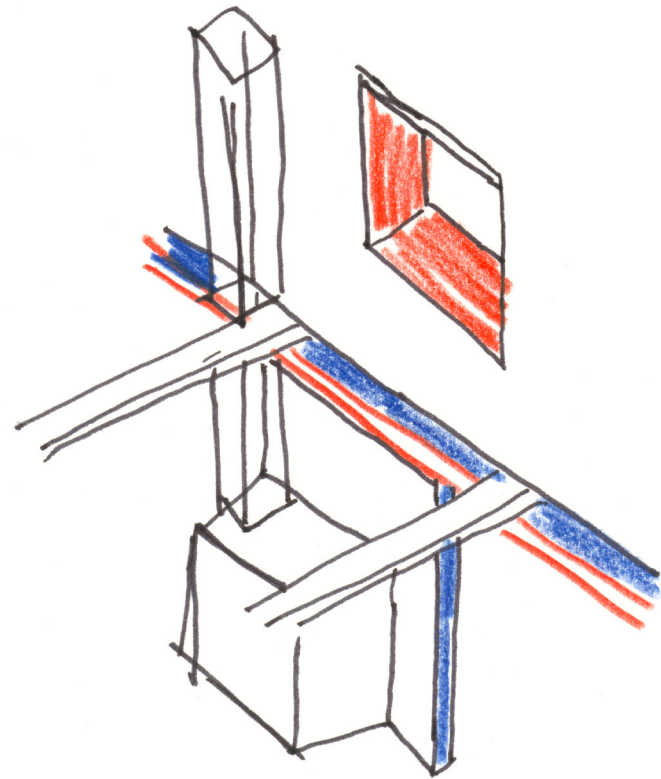

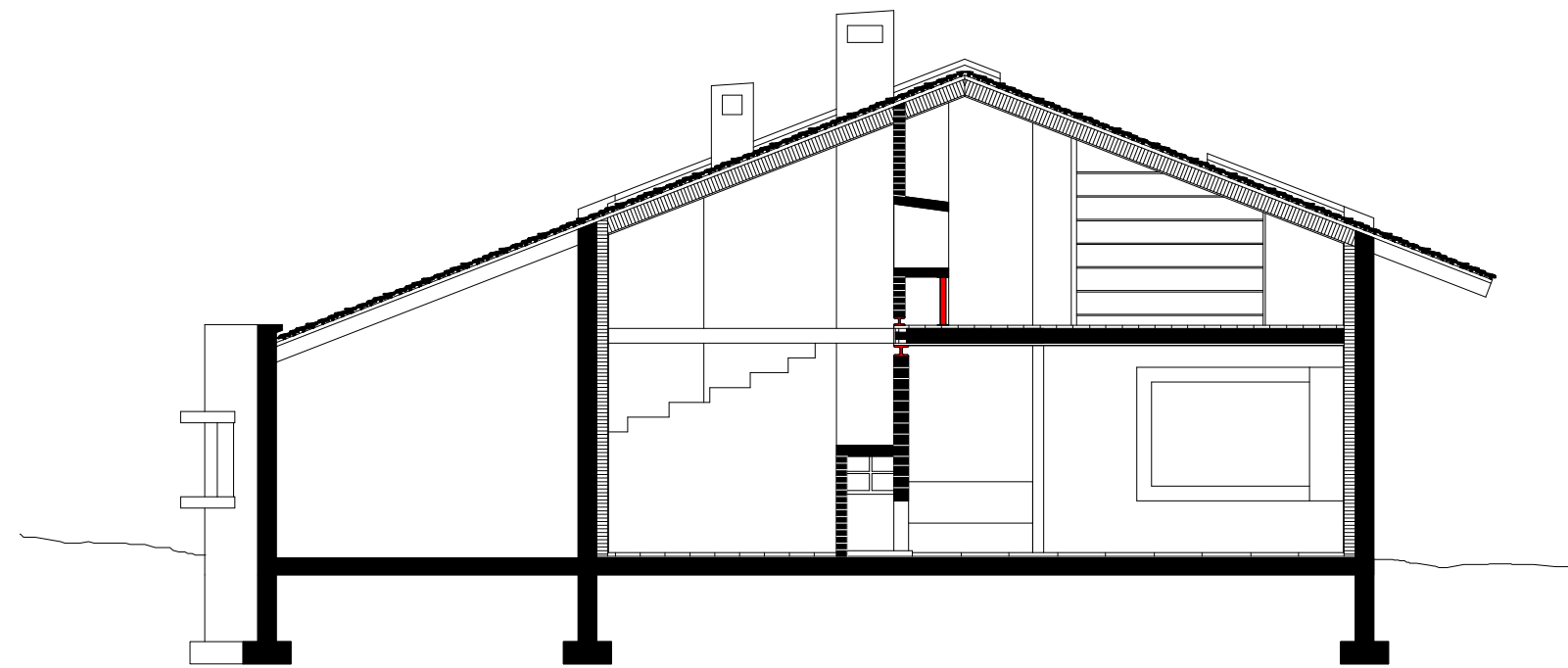
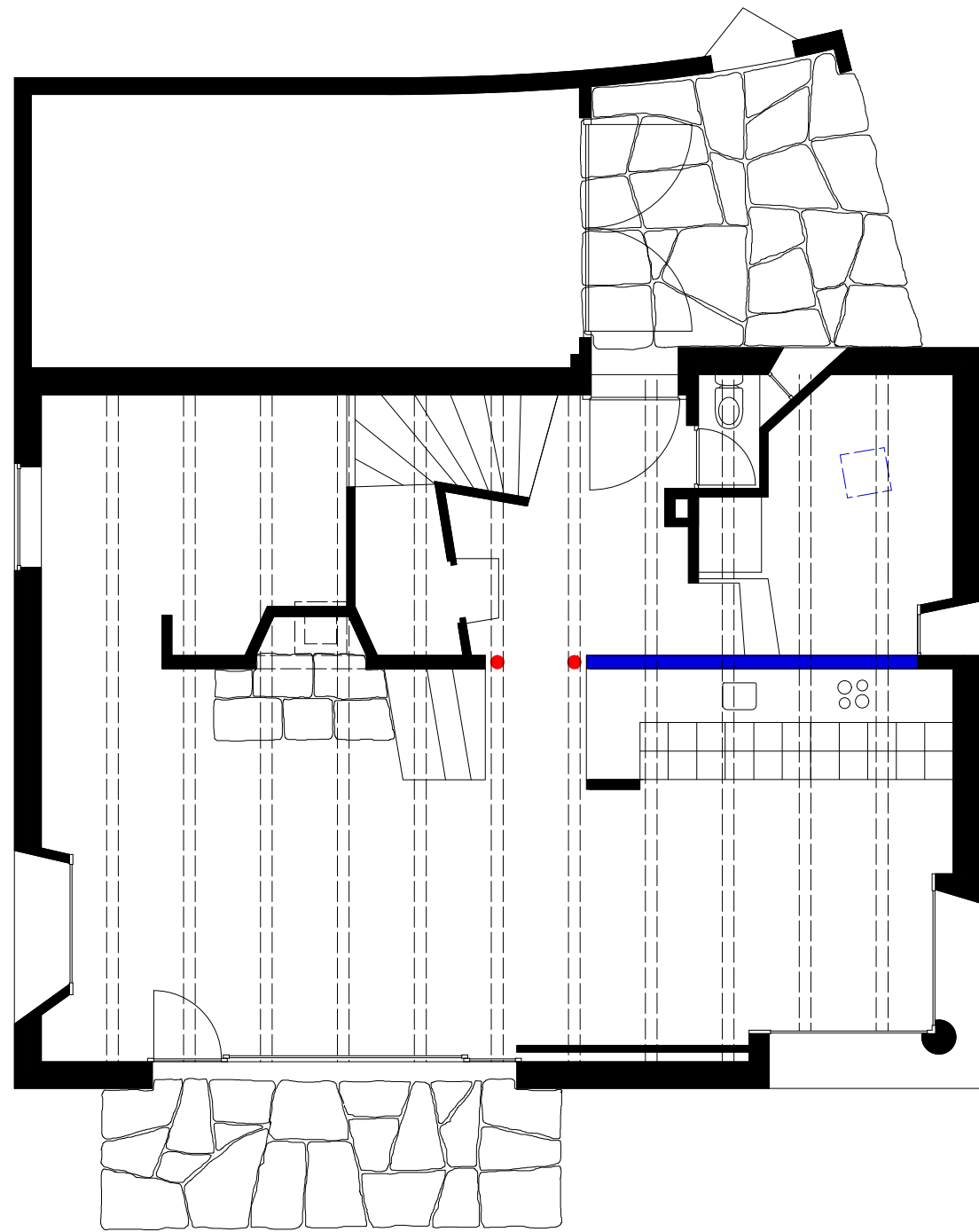



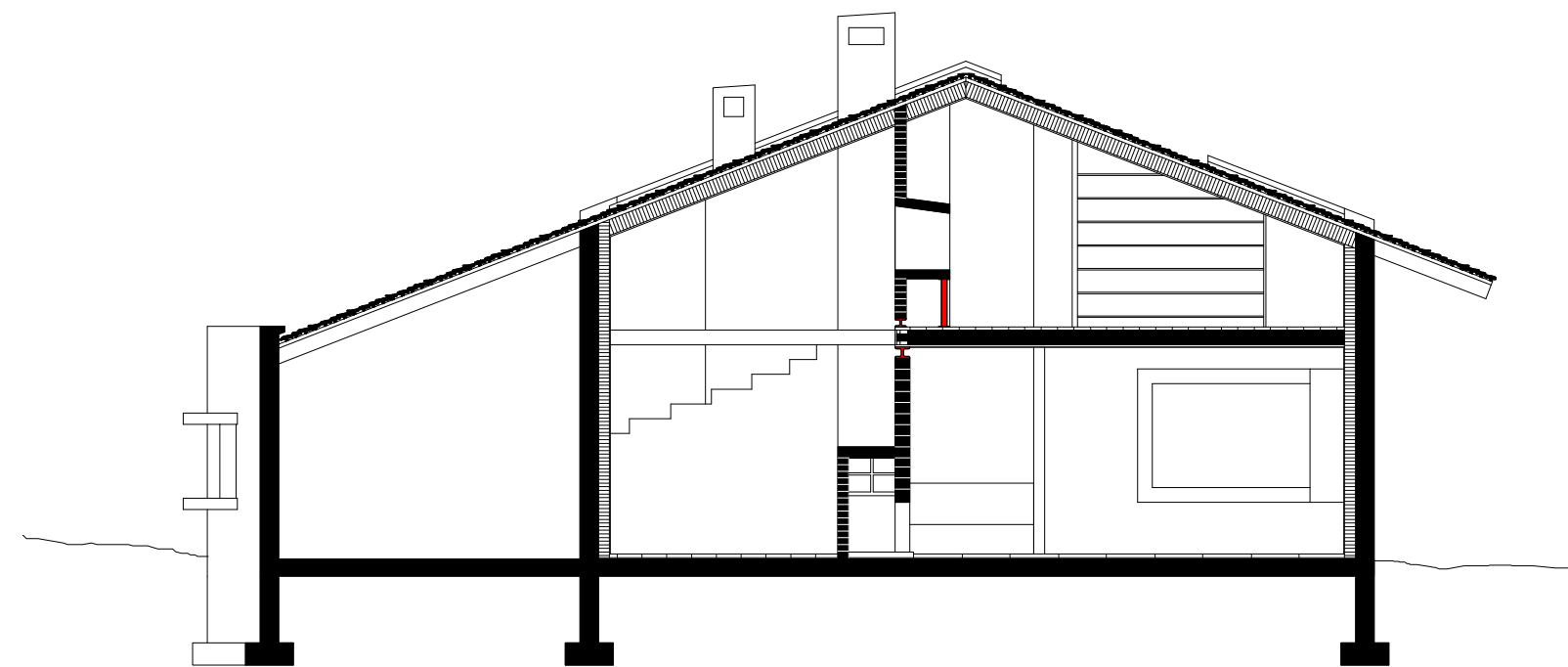
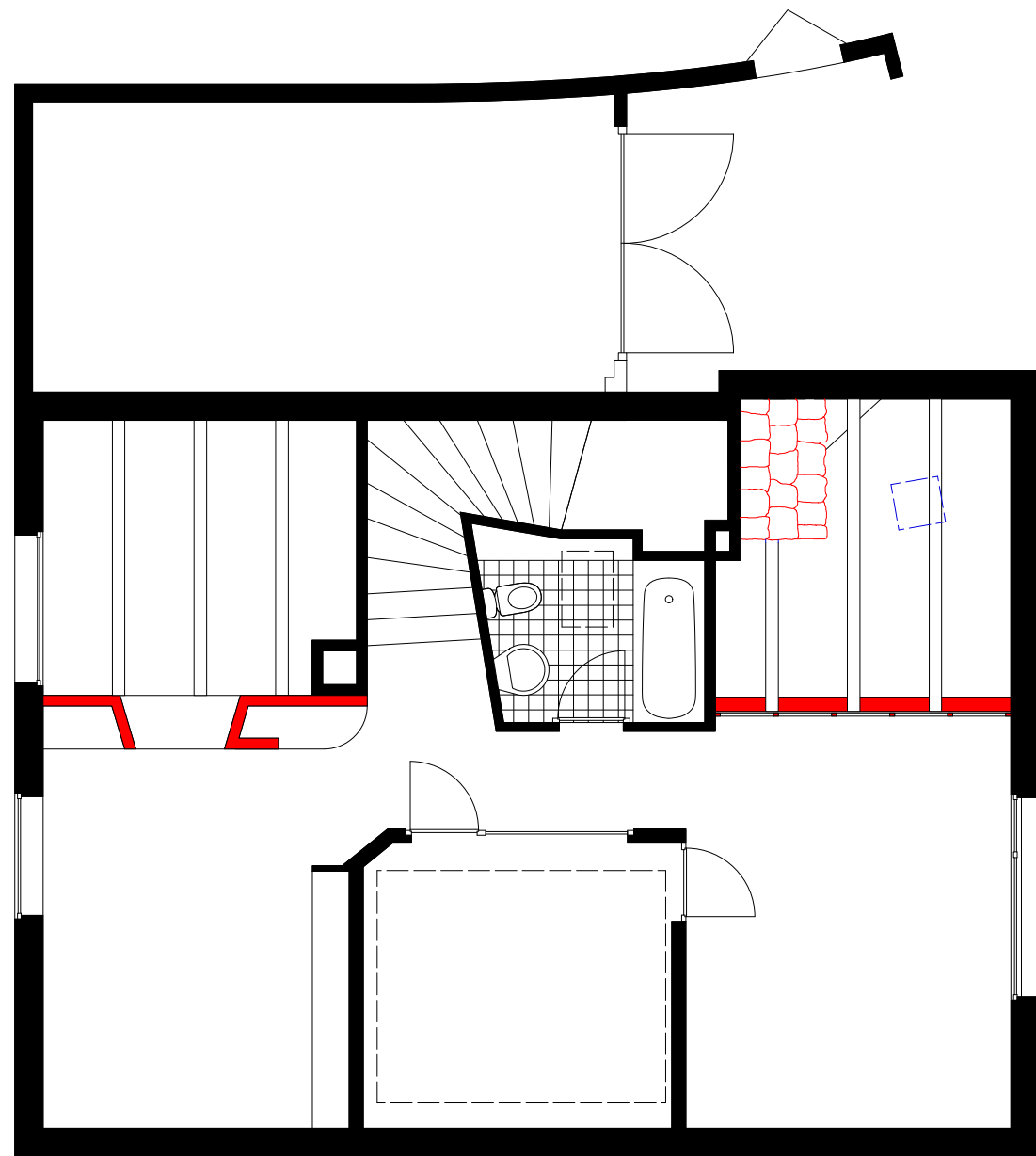

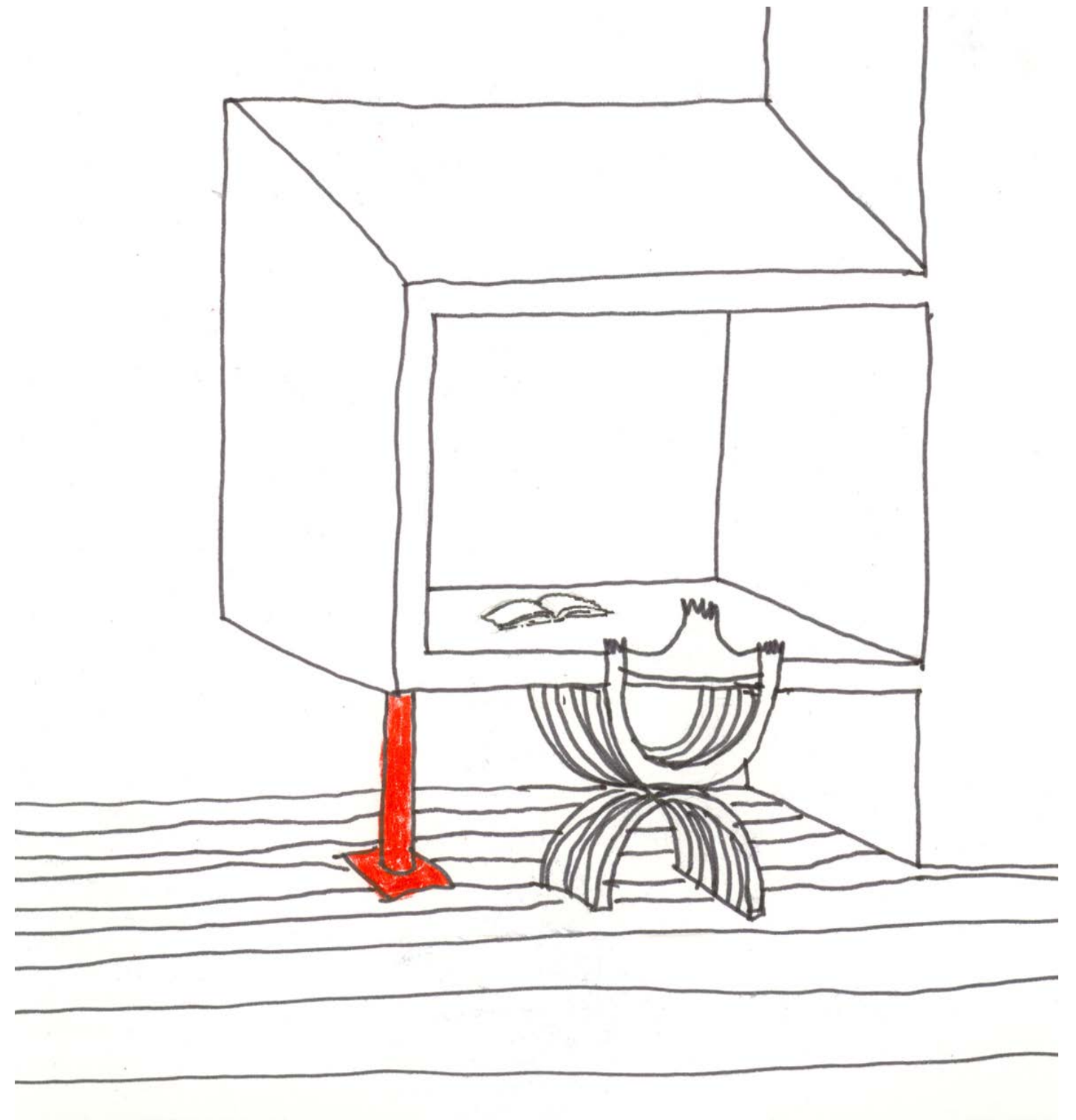
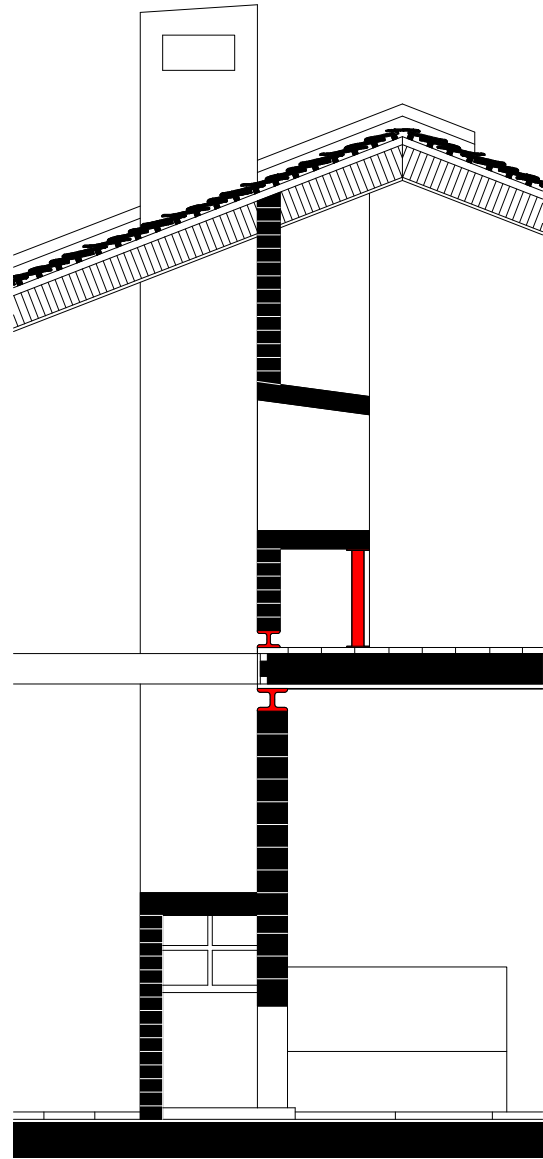

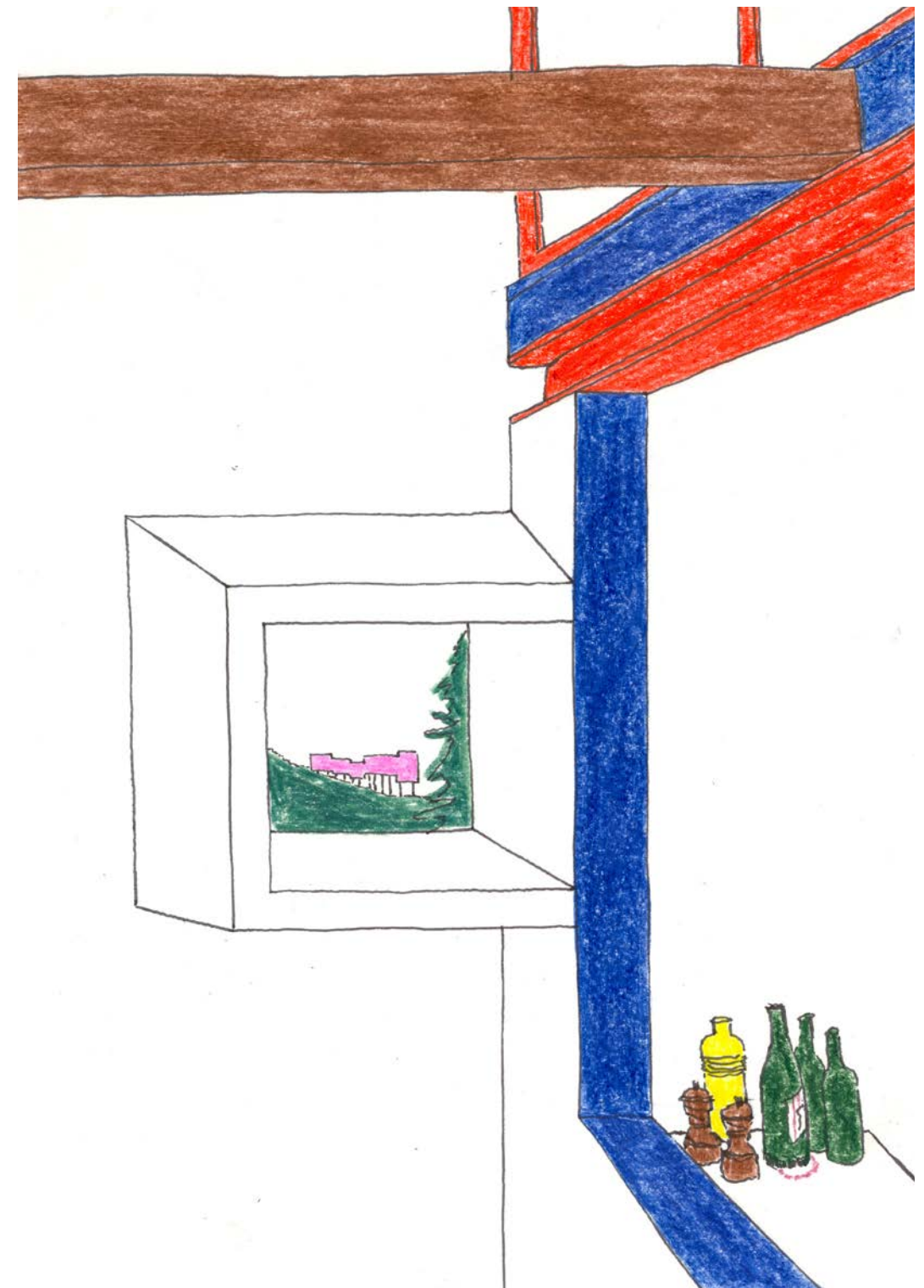
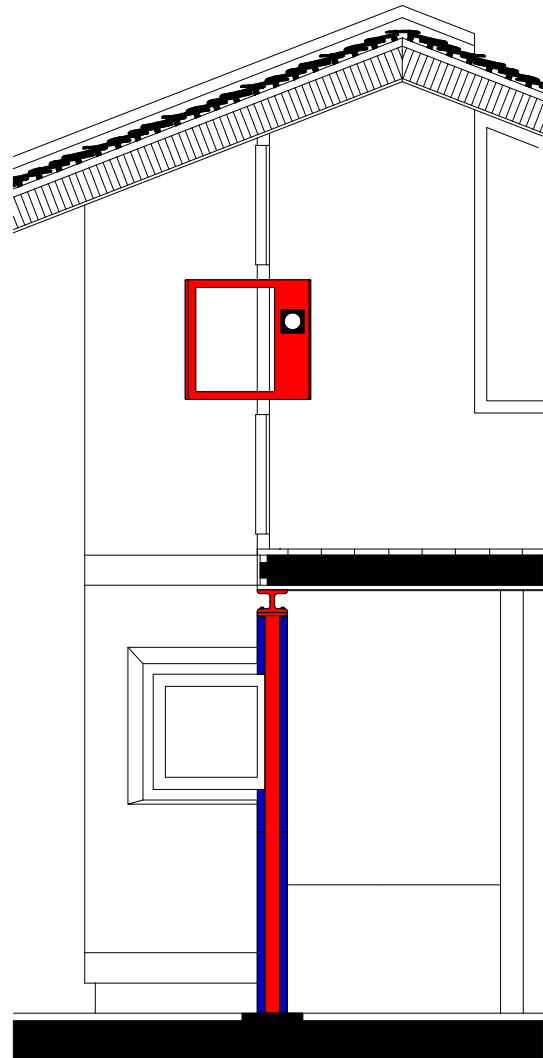

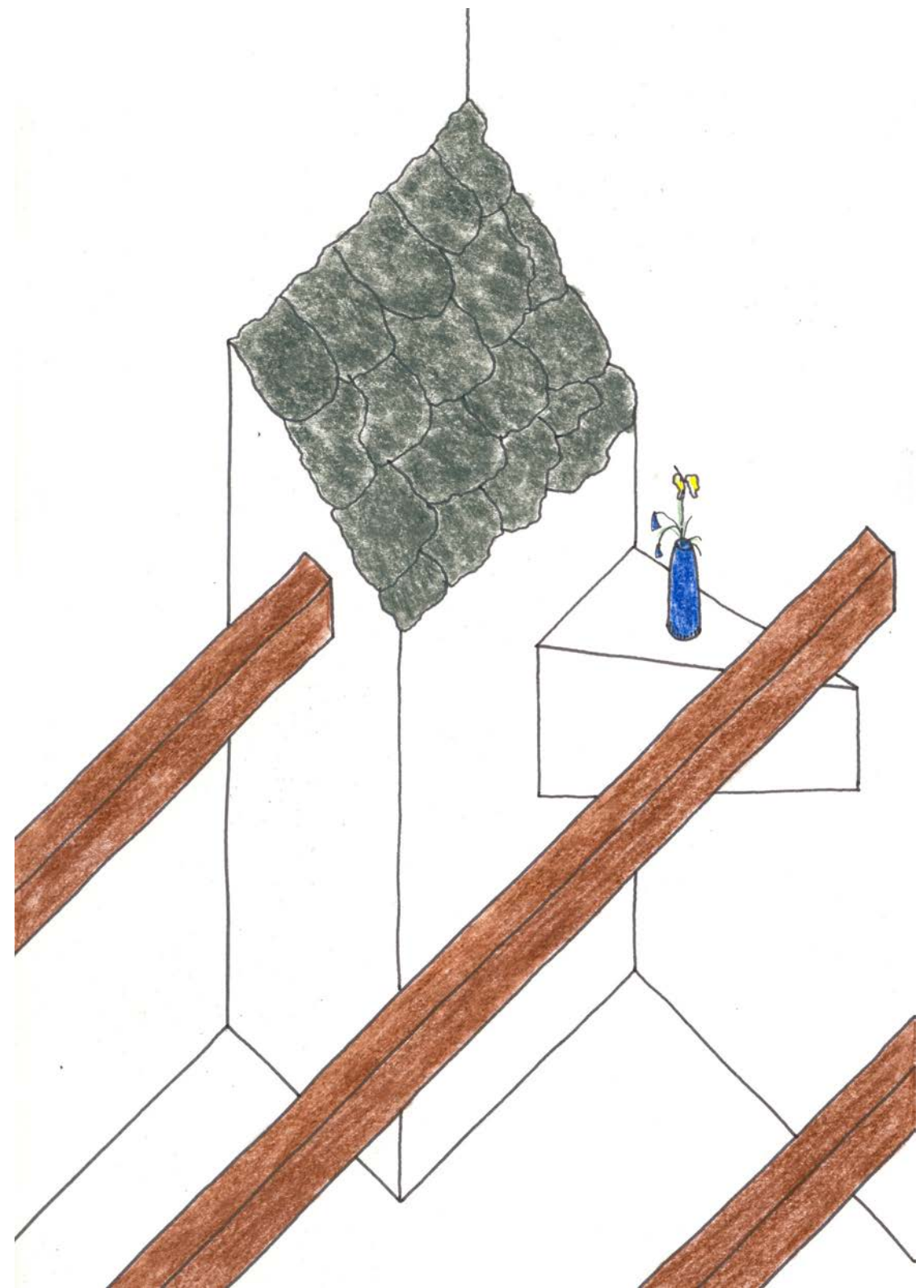
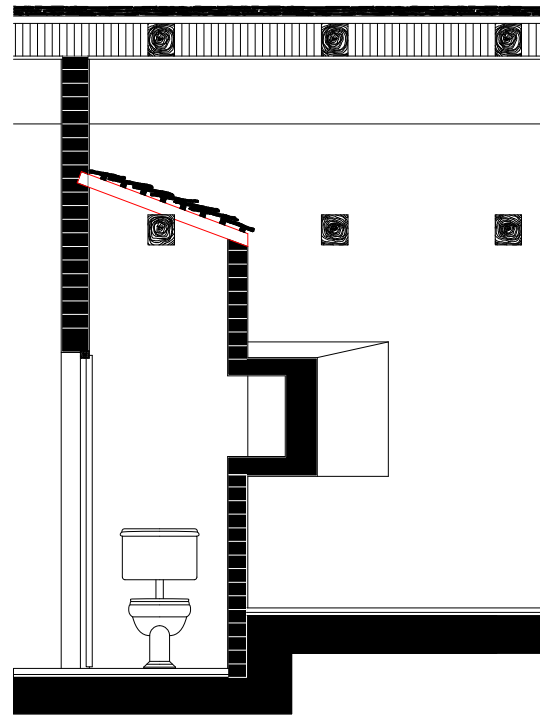

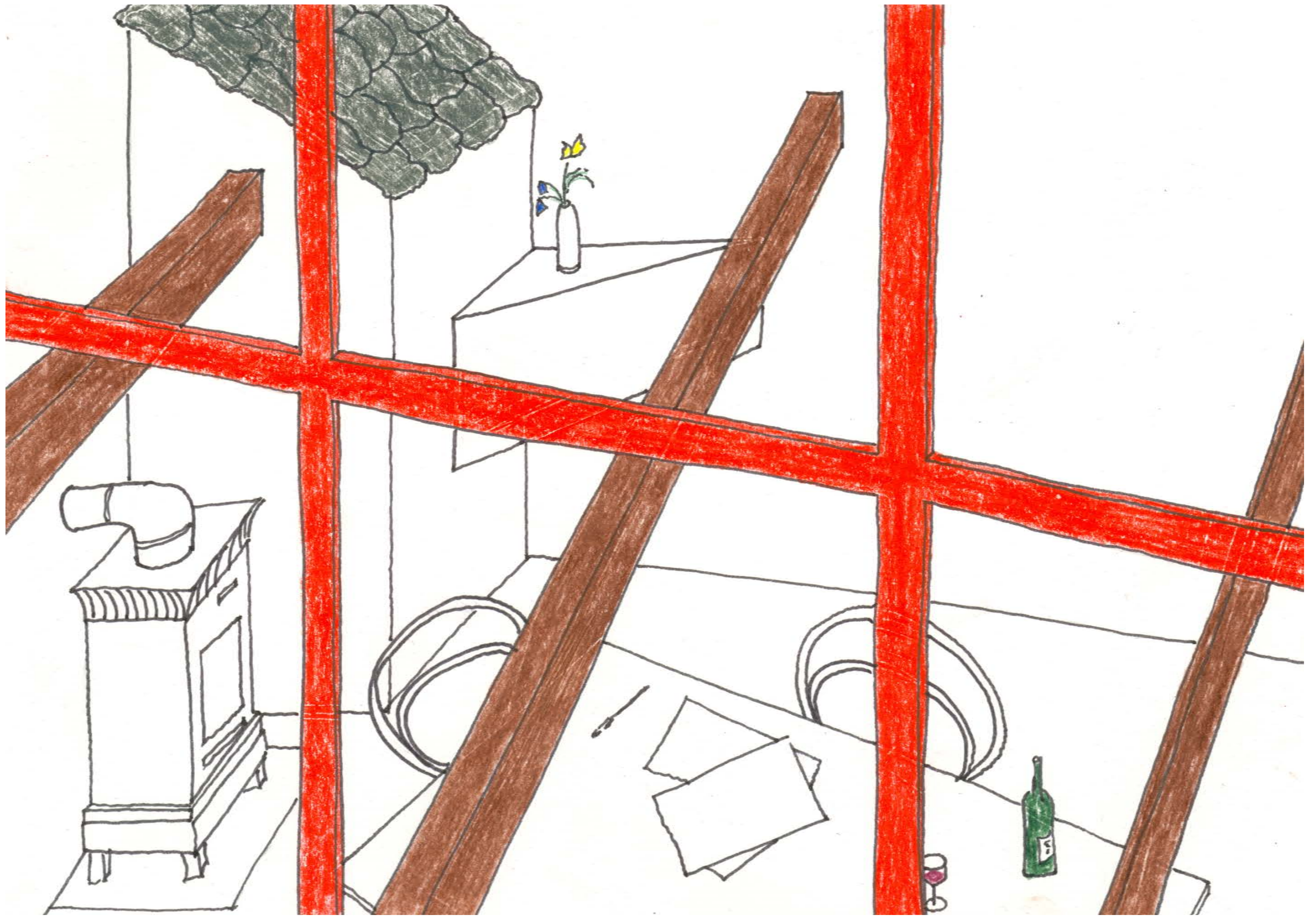



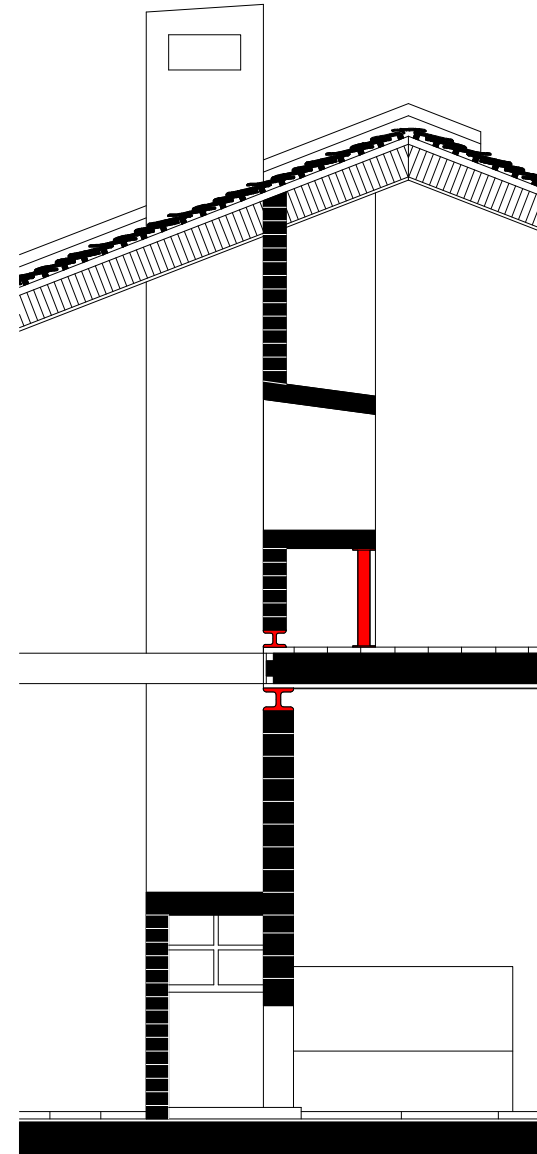
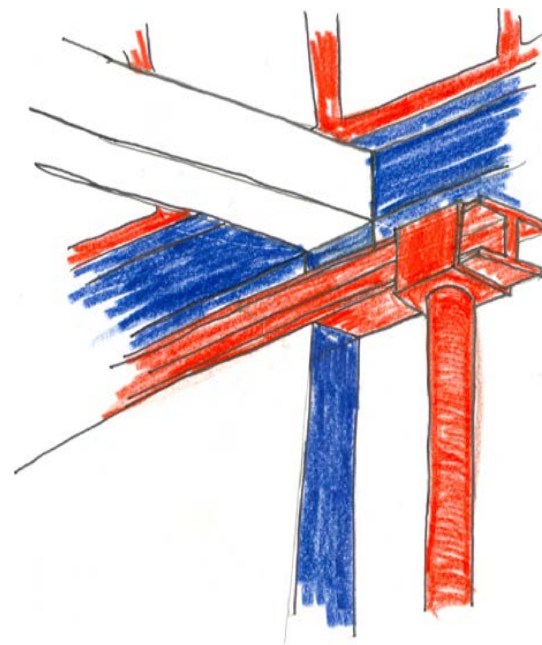
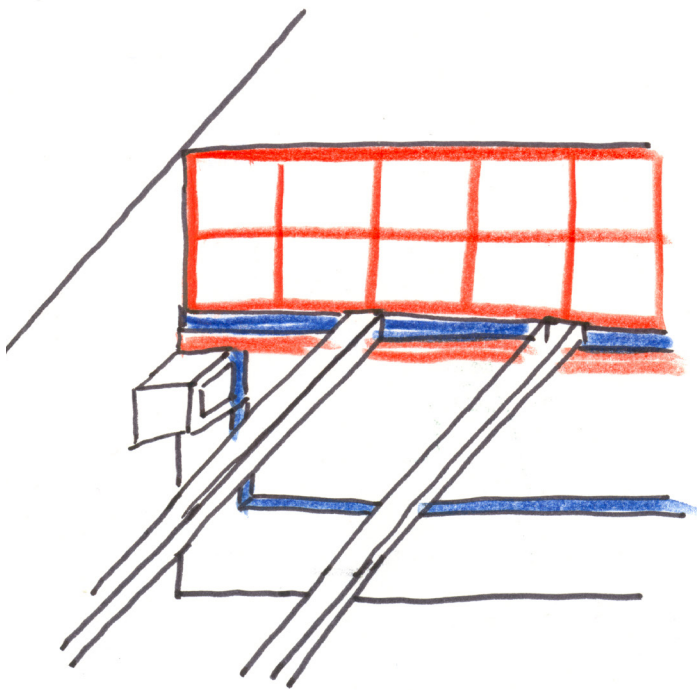
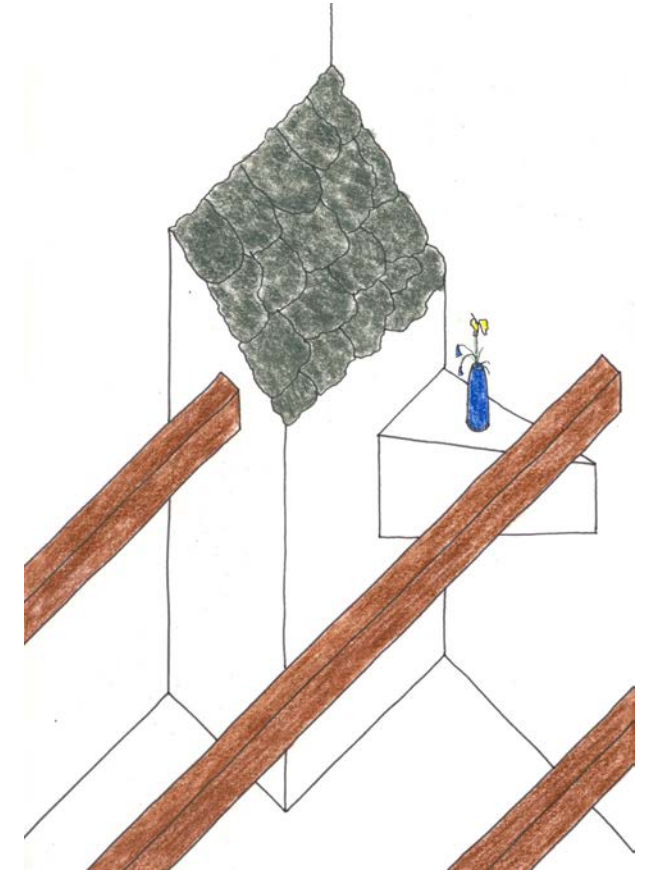
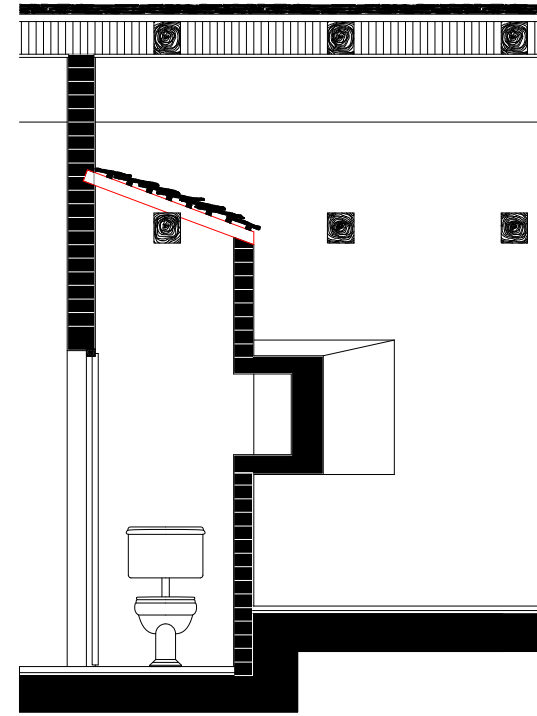
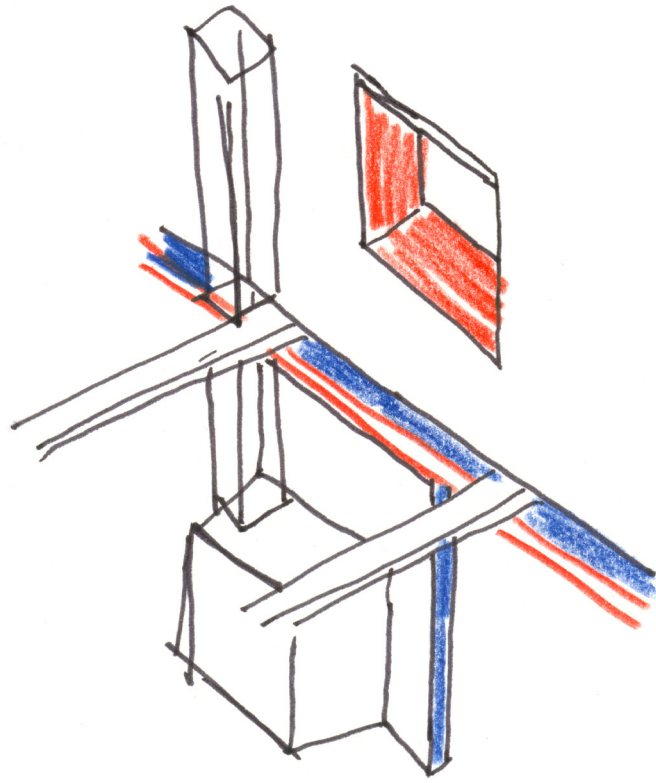
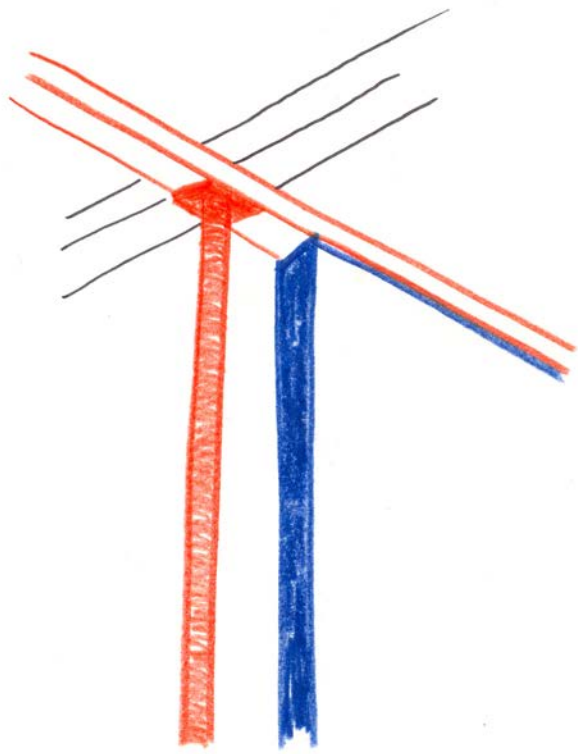

## Movement 2

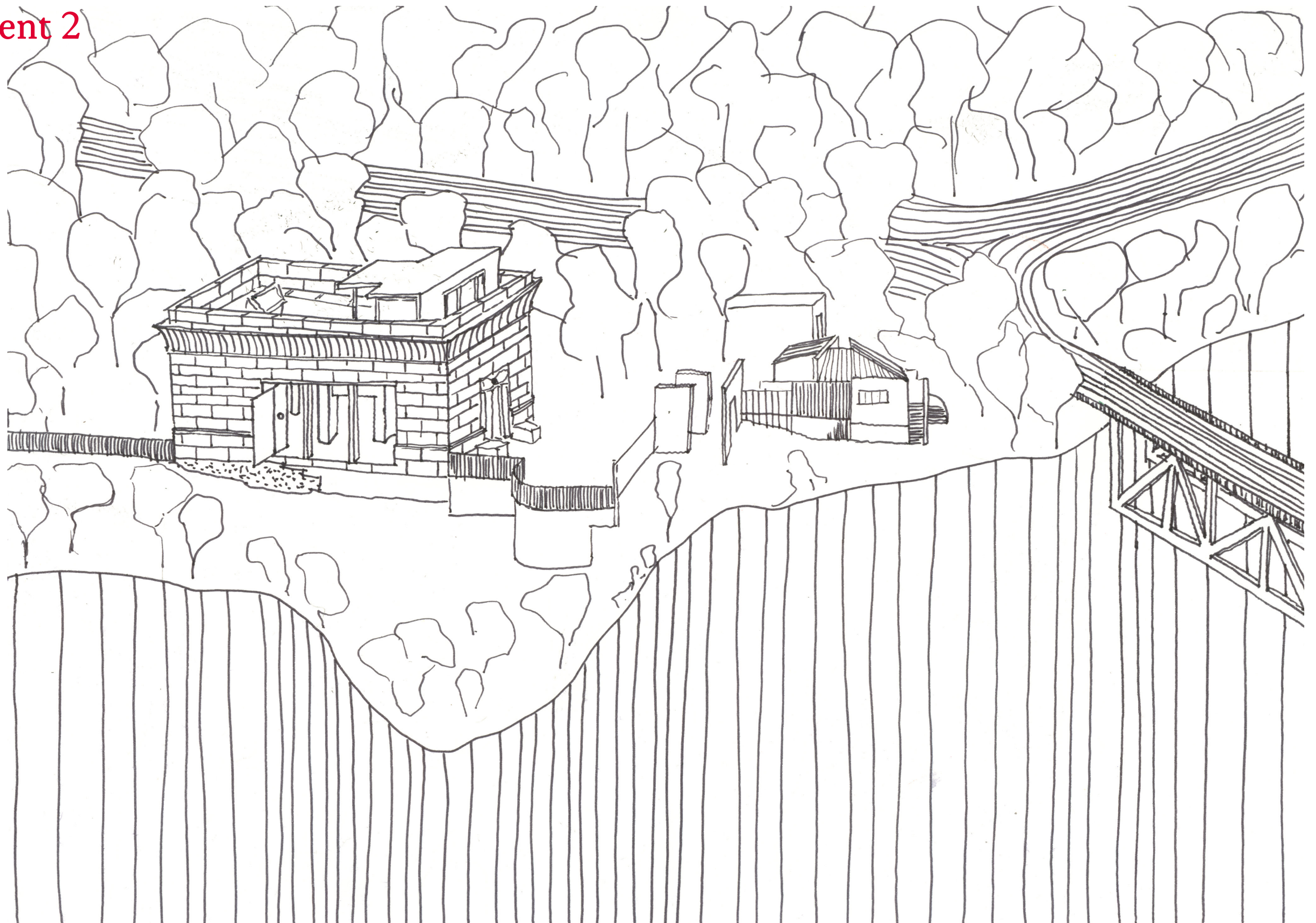



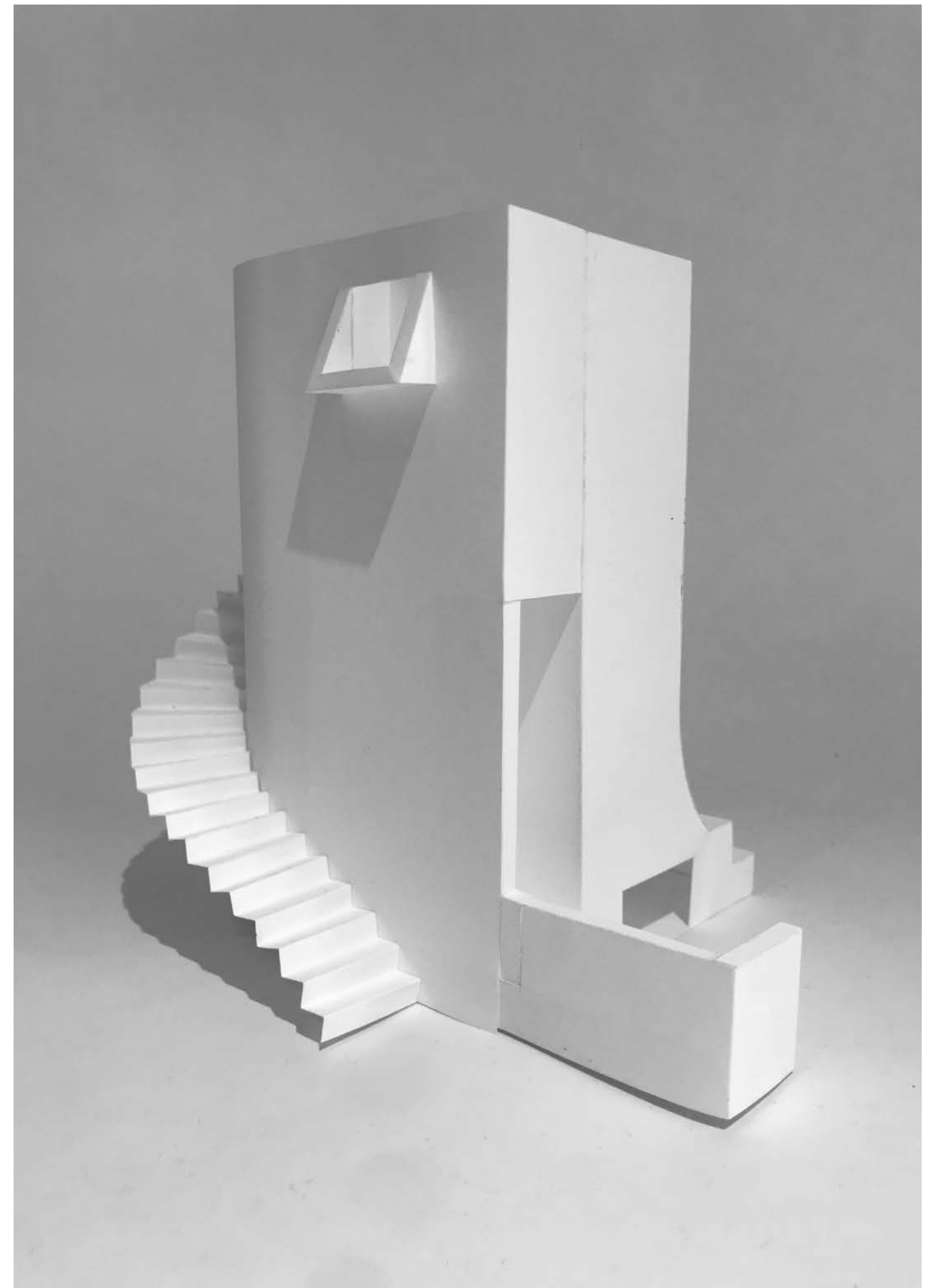
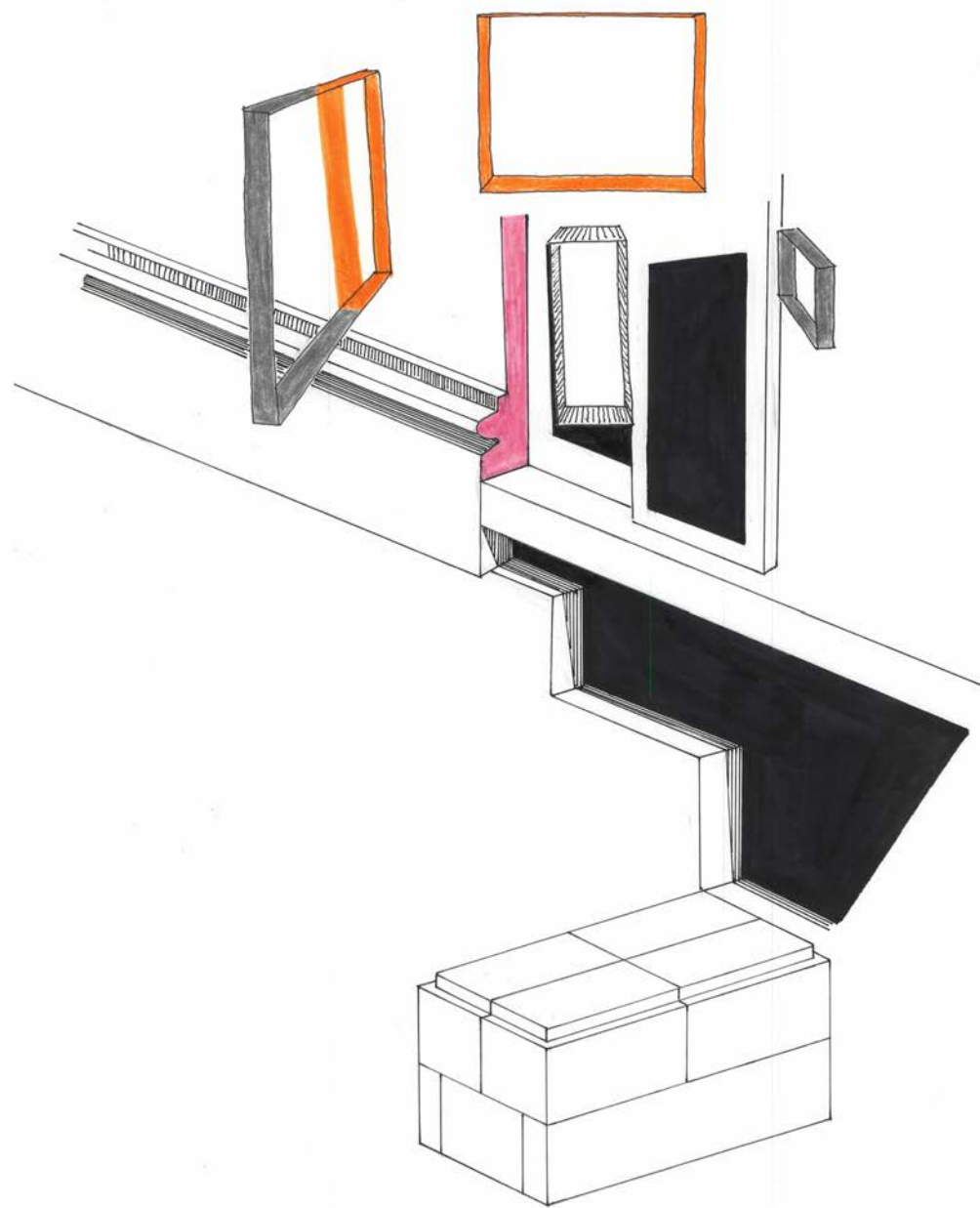

## don't judge a house by its walls

Many people have asked me if I'm lonely, and I can tell they don't quite believe me when I tell them I'm not. Maybe if they had found a home fitted to them as I have, like a leaf to a tree, a drop of water to a pond, then they would begin to understand. How the sphinx and my work and myself have all become a little bit tangled. The sphinx influences my creations, and my creations influence me, and in turn I influence the sphinx. Sometimes I reach a dead end, where I cannot link words to sentences anymore, and my mind falls silent. Then I walk through the house, climbing stairs and turning corners, following the walls I know so well I am never lost between them. Every path I take leads to a comfortable niche to take refuge in, or a bright window to look out from, or an open space to occupy.



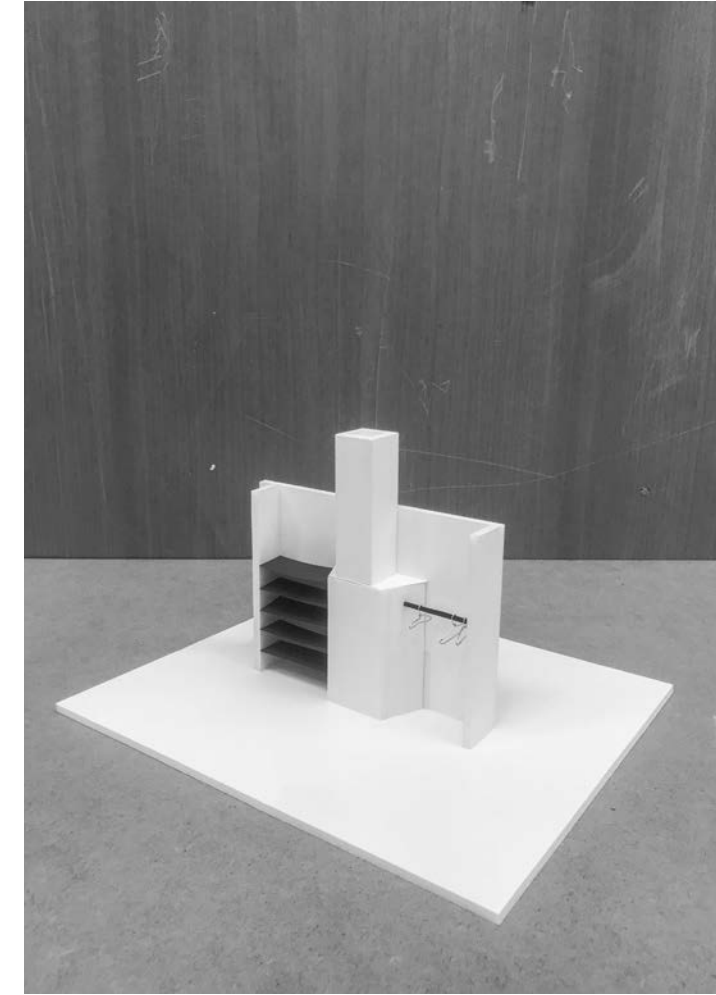
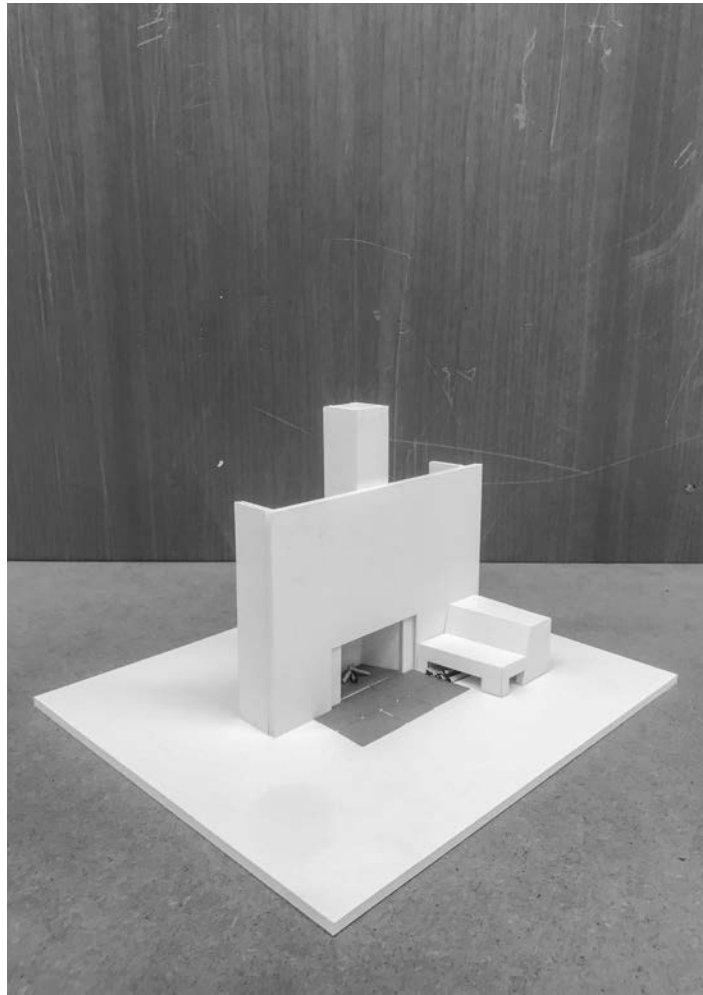





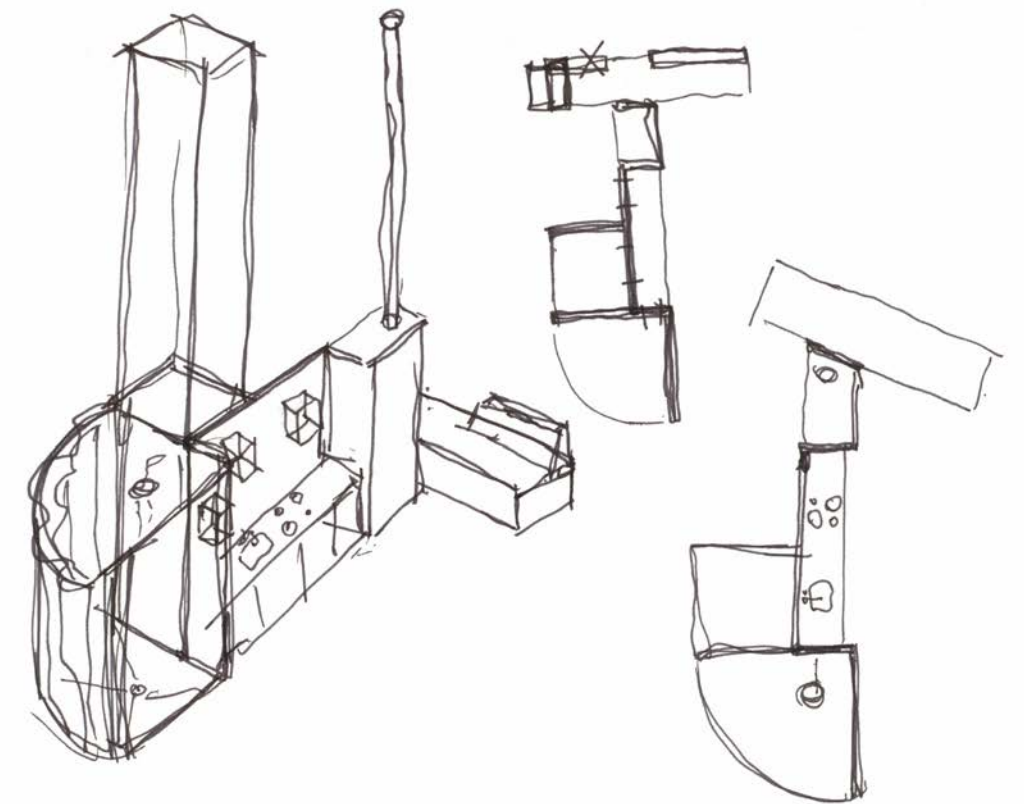
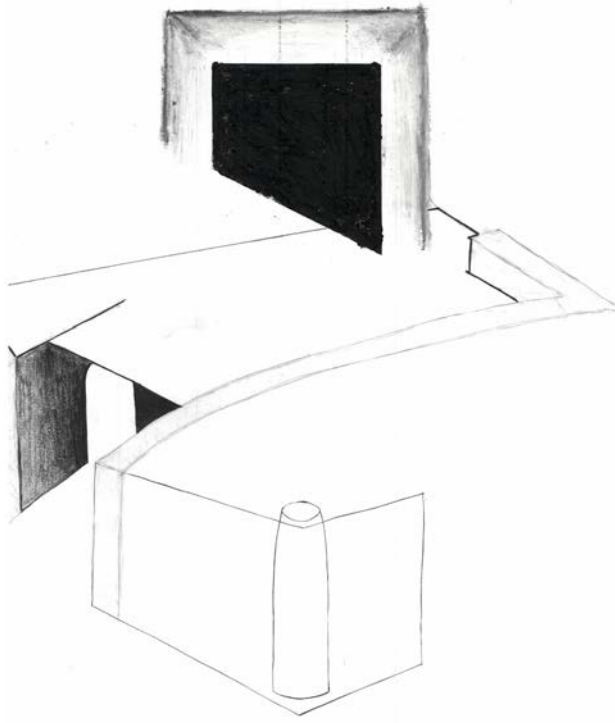

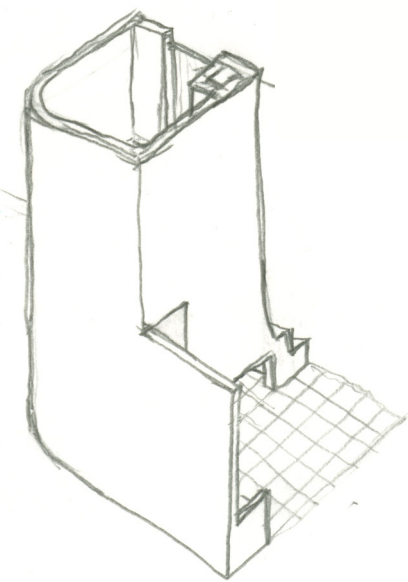
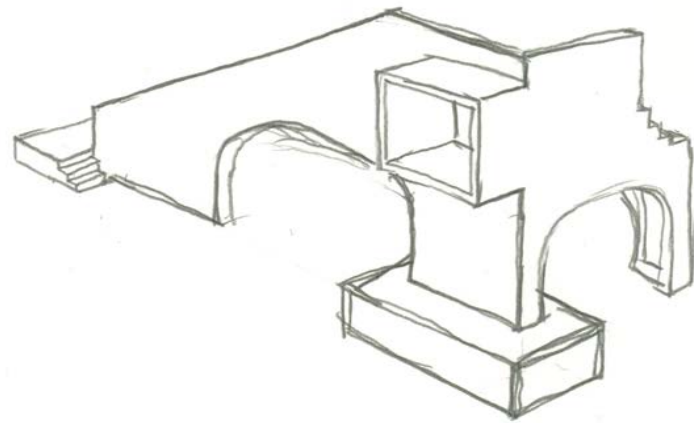
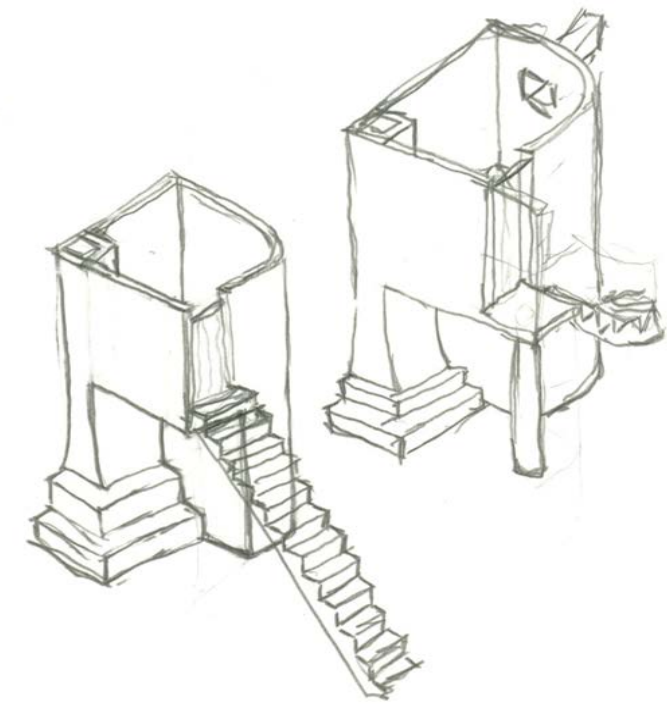
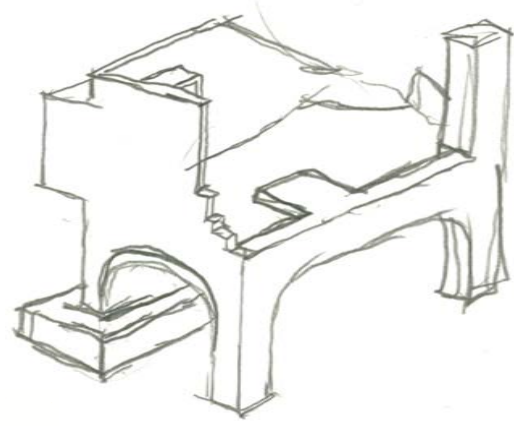

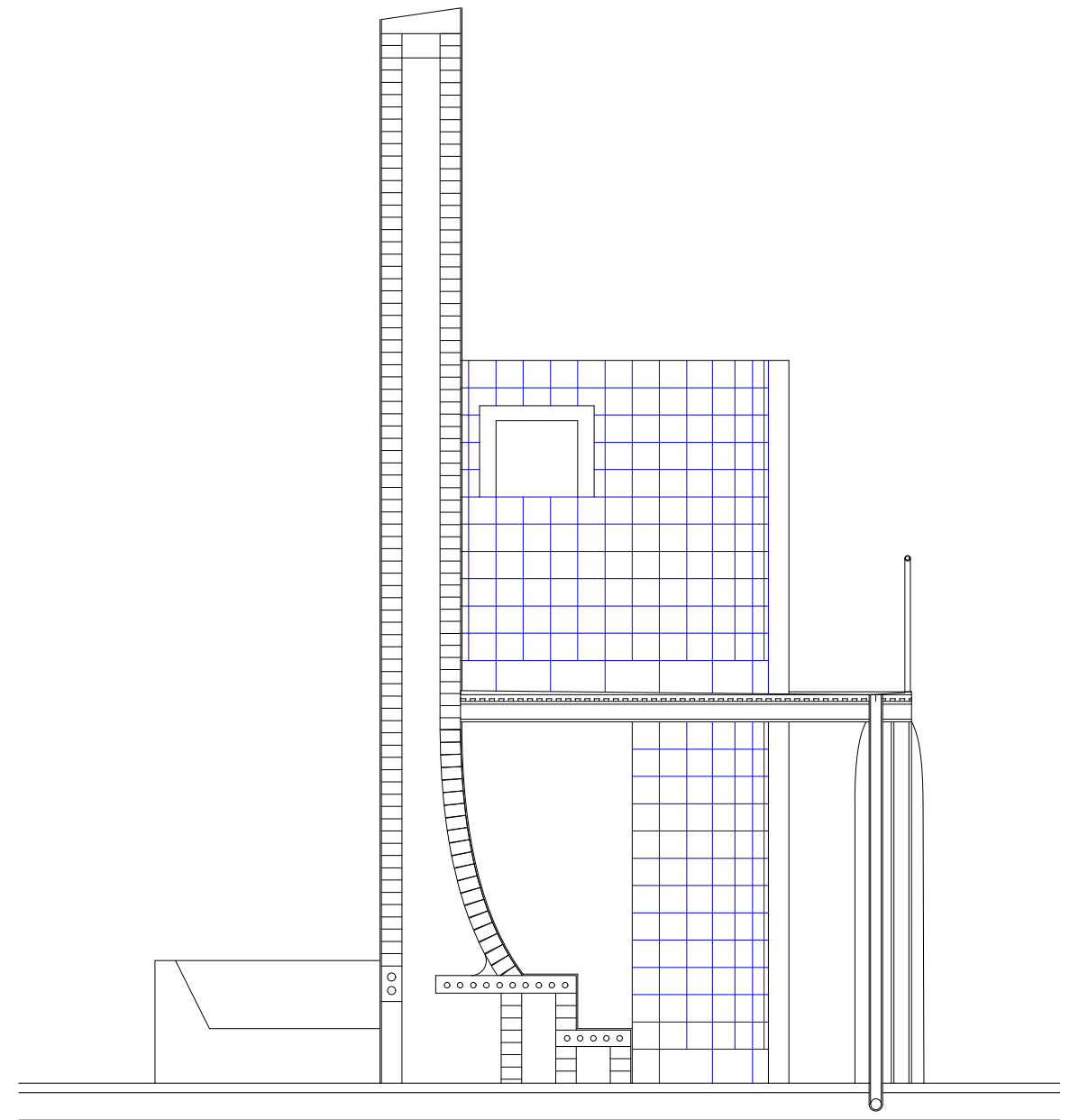
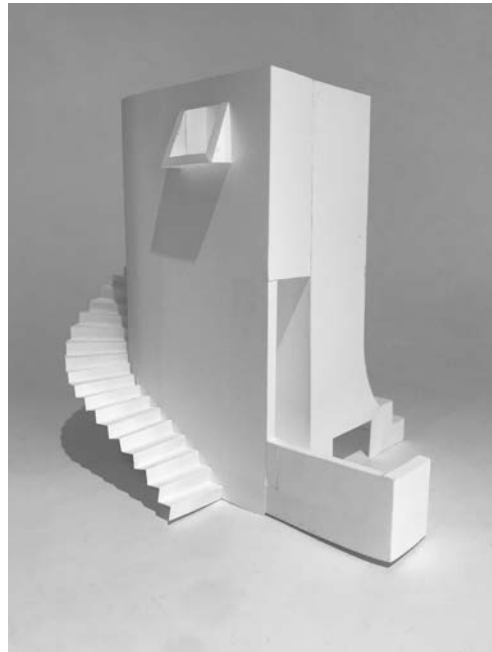



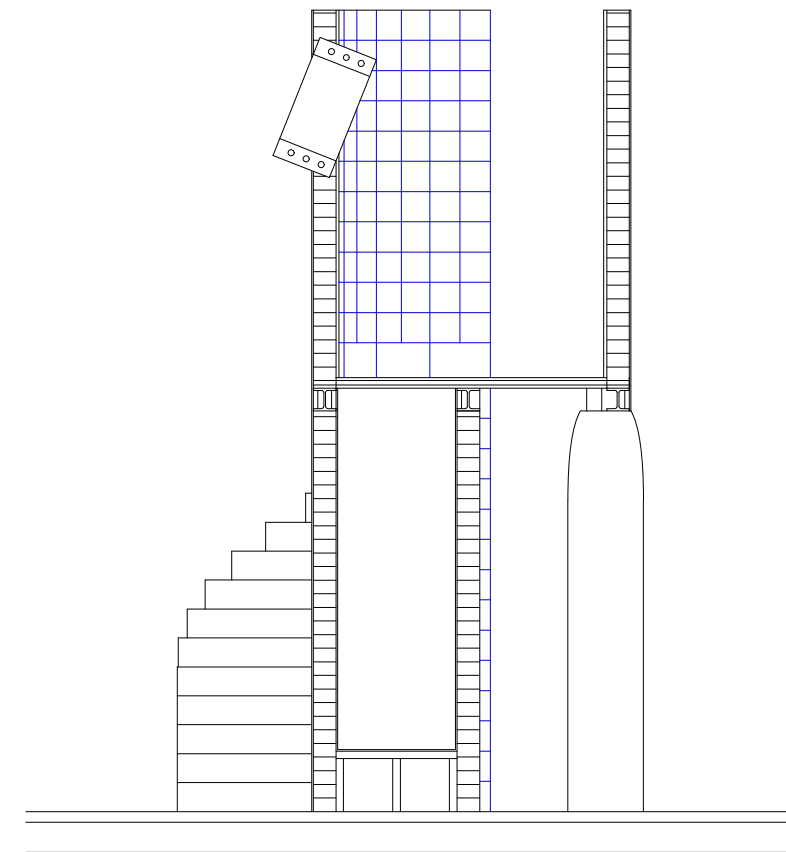
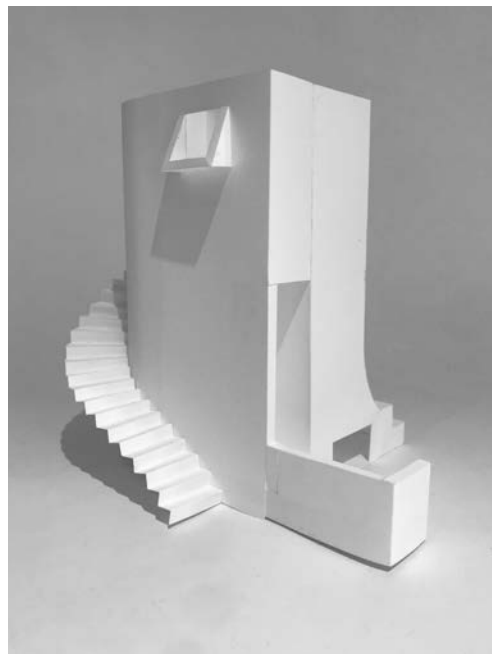

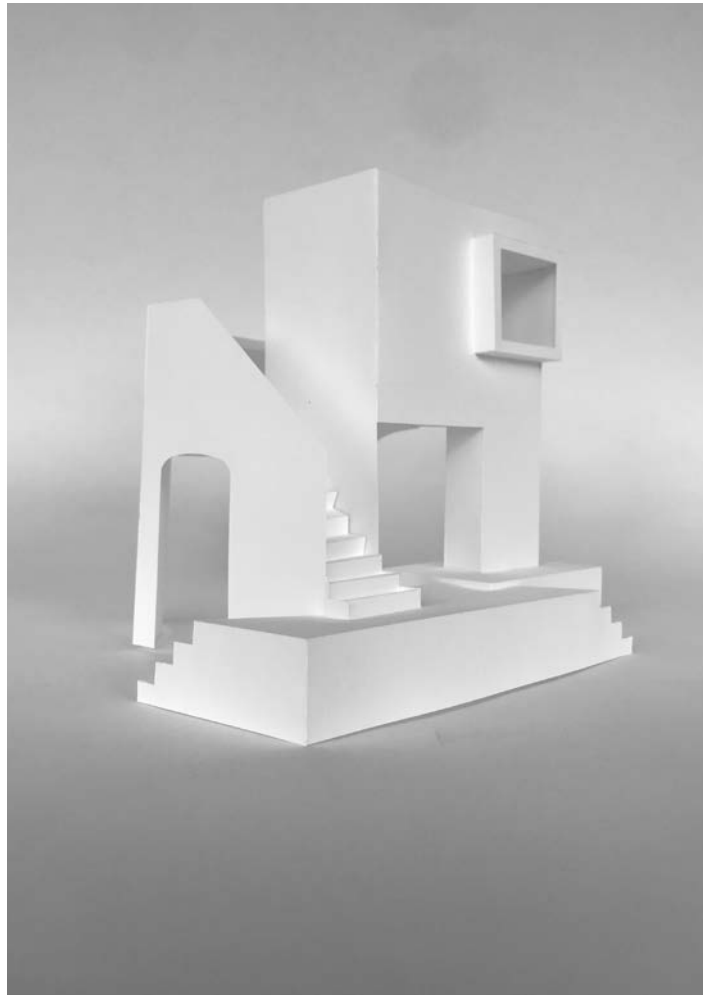

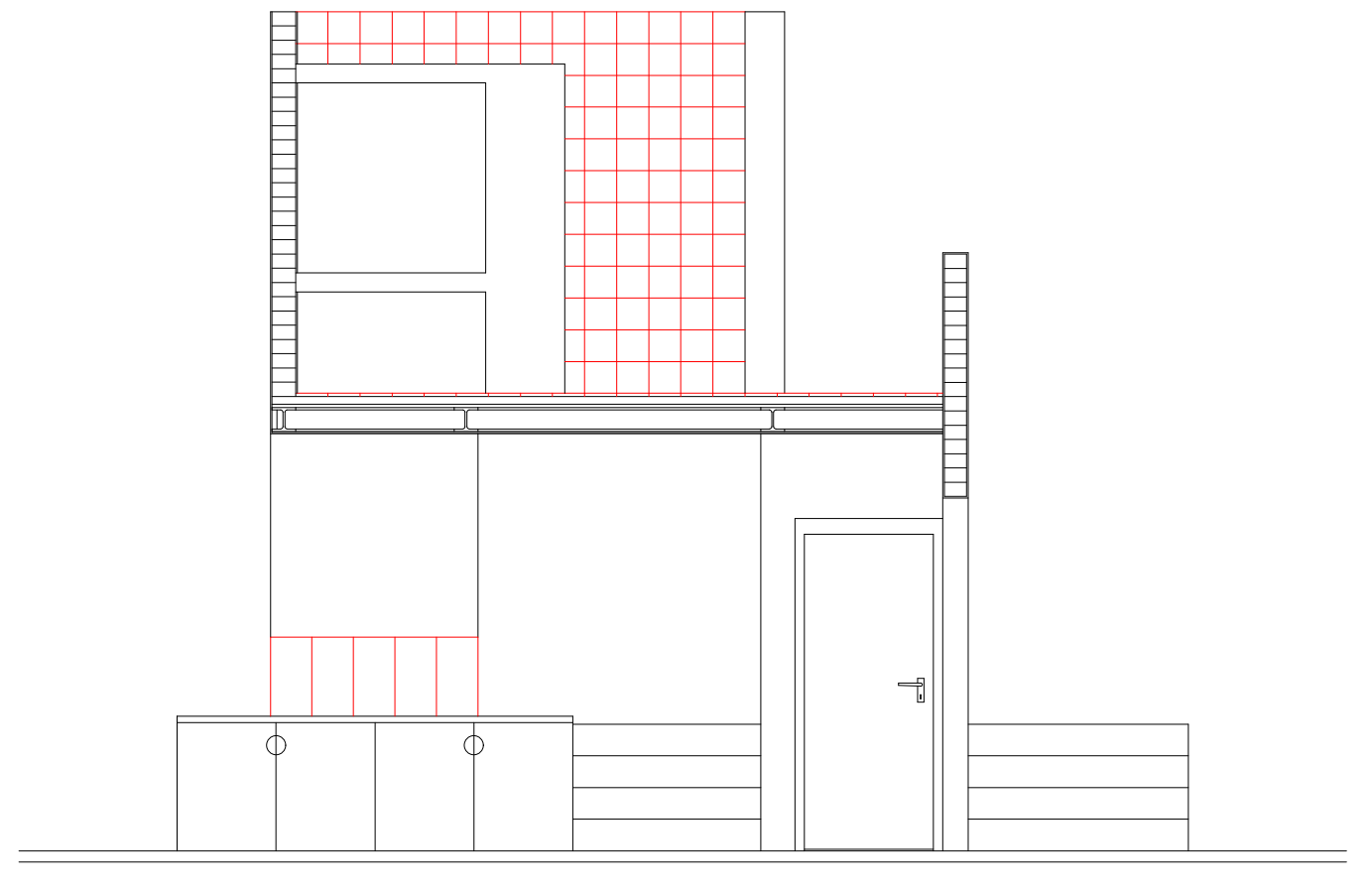
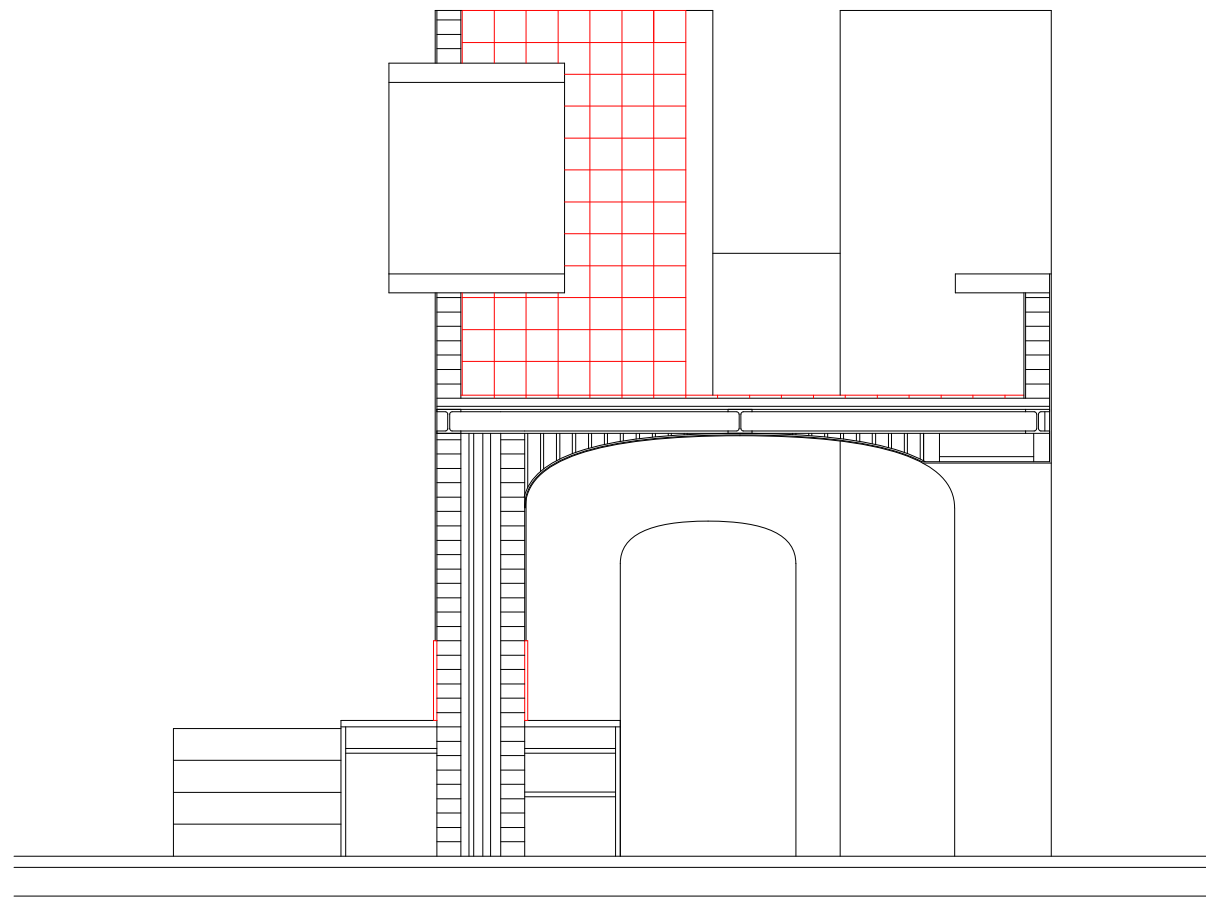

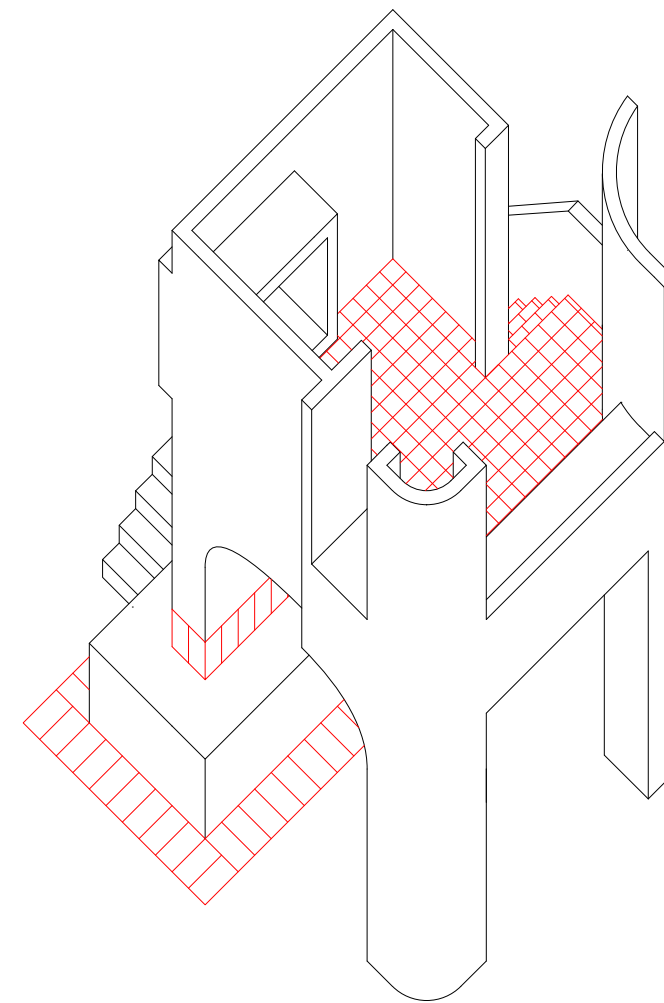
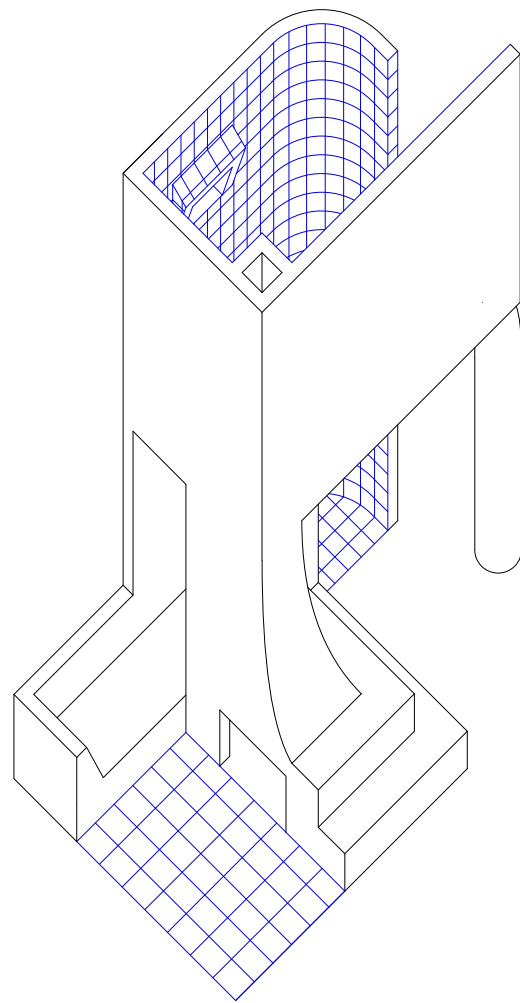

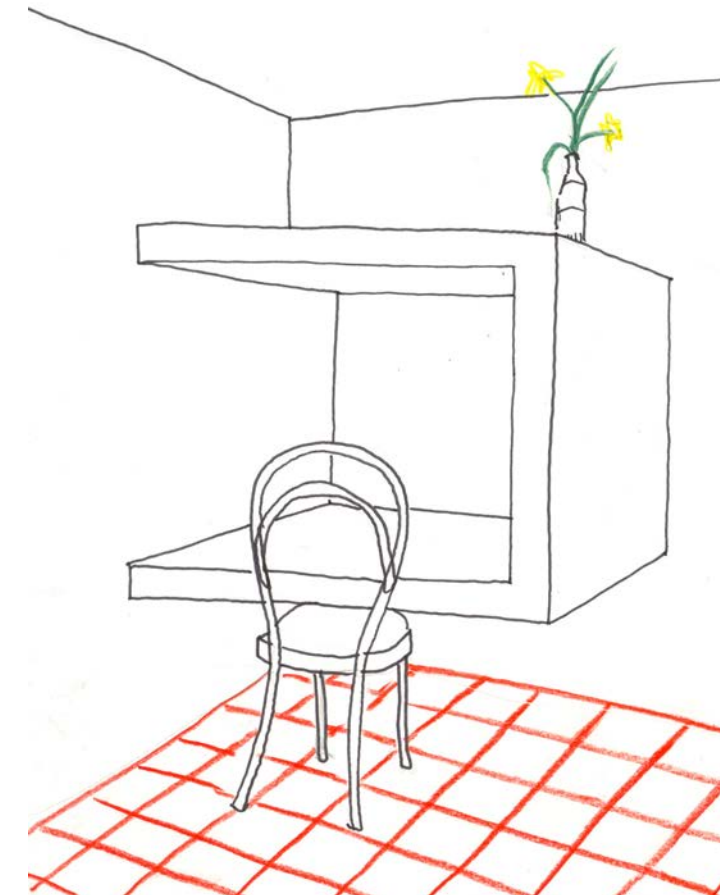
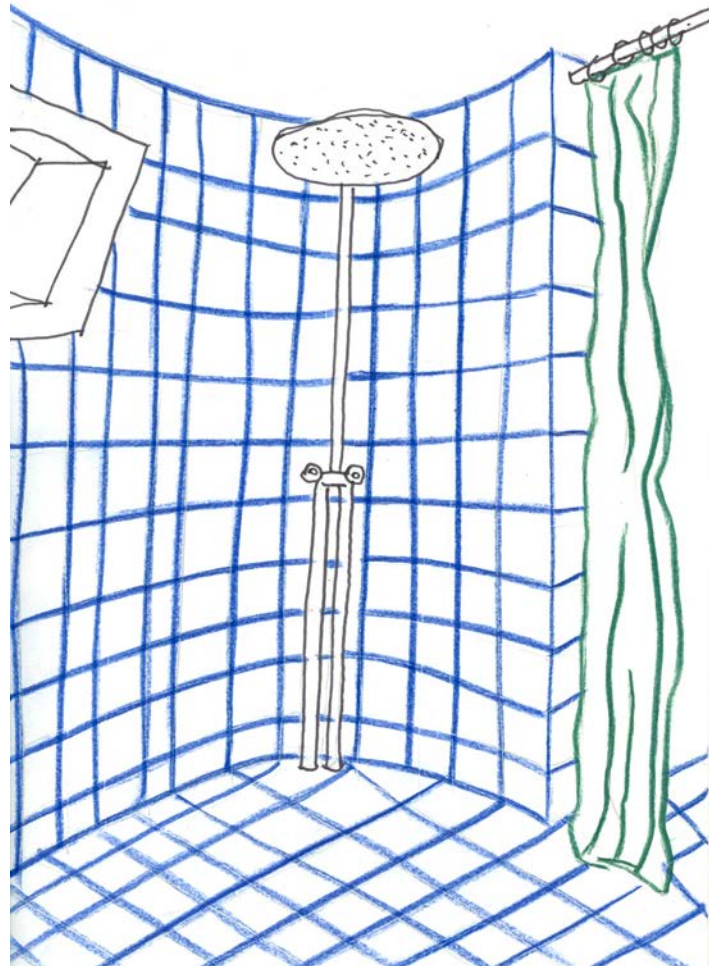

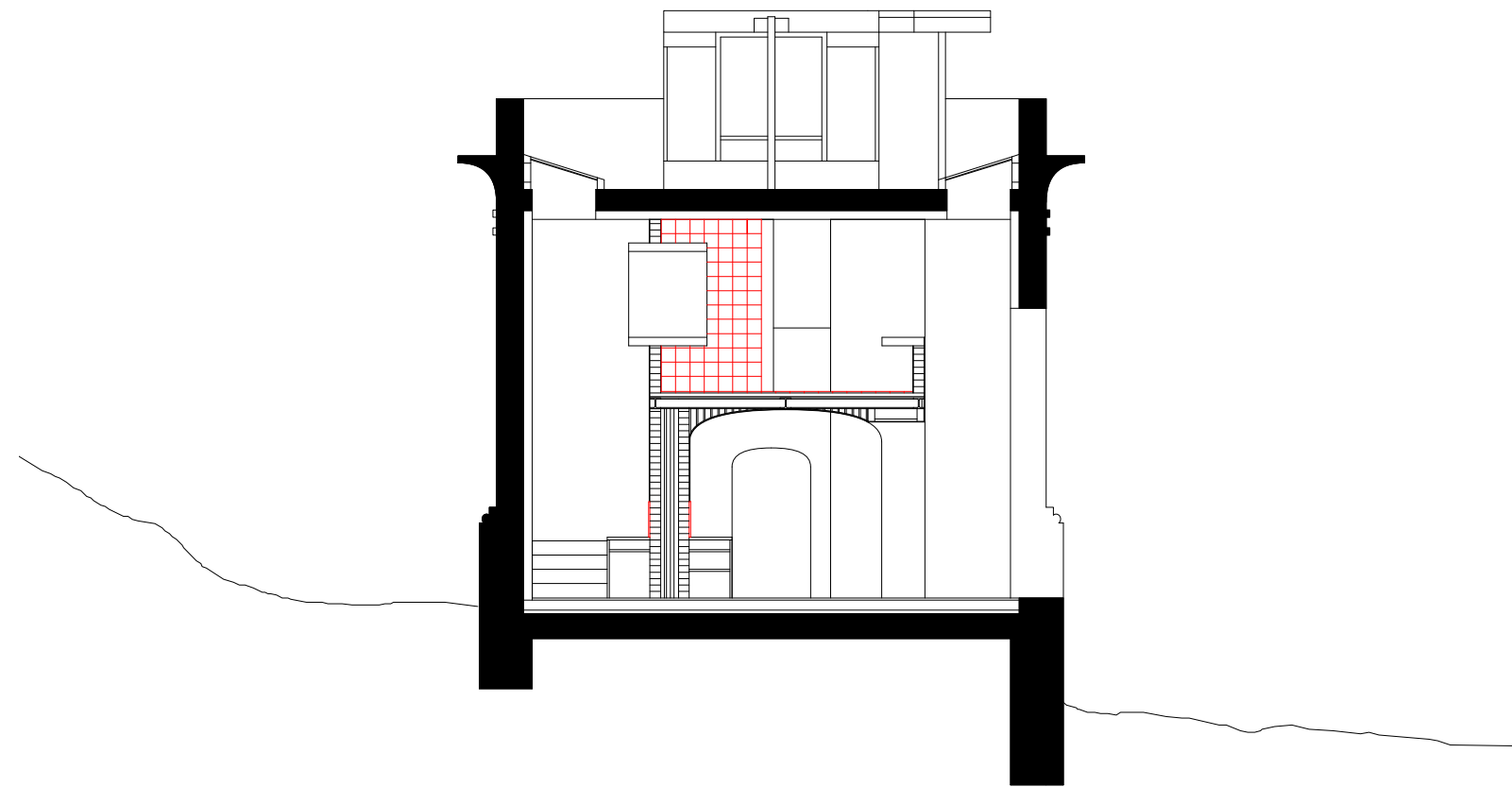
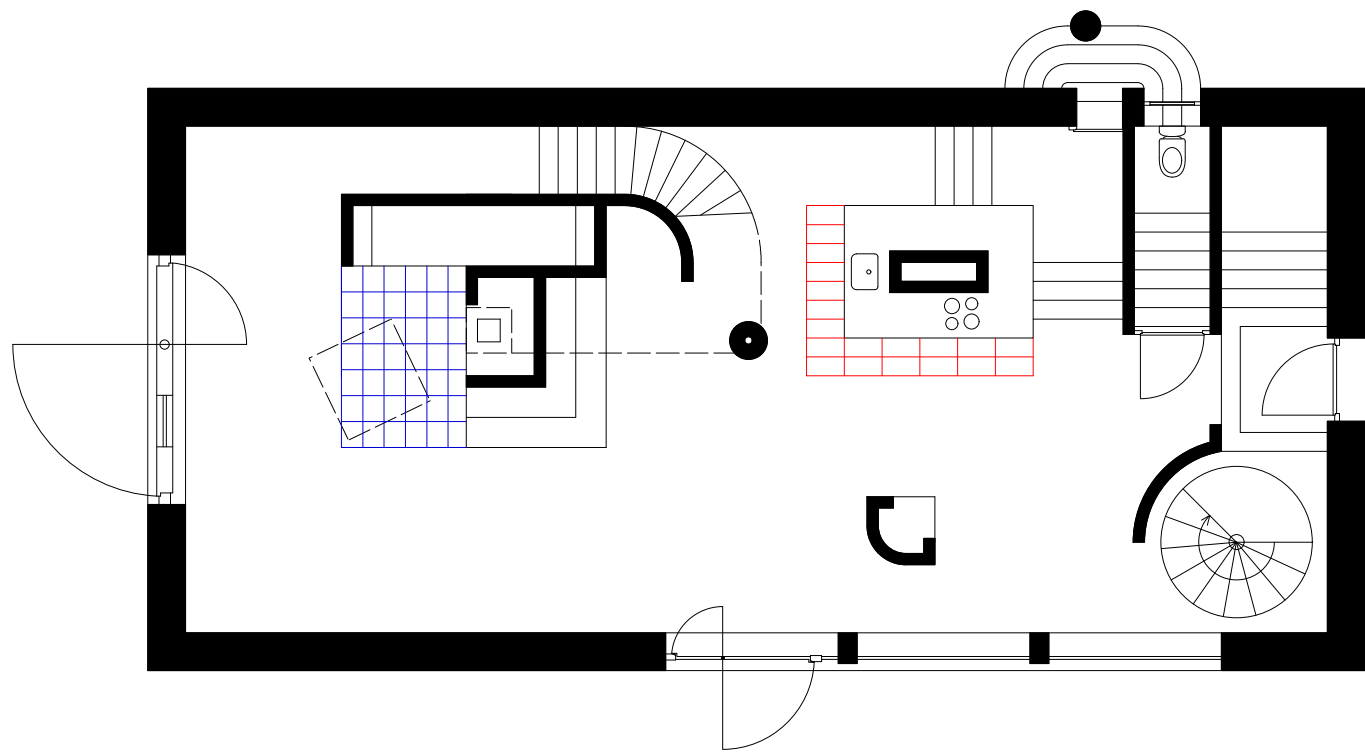
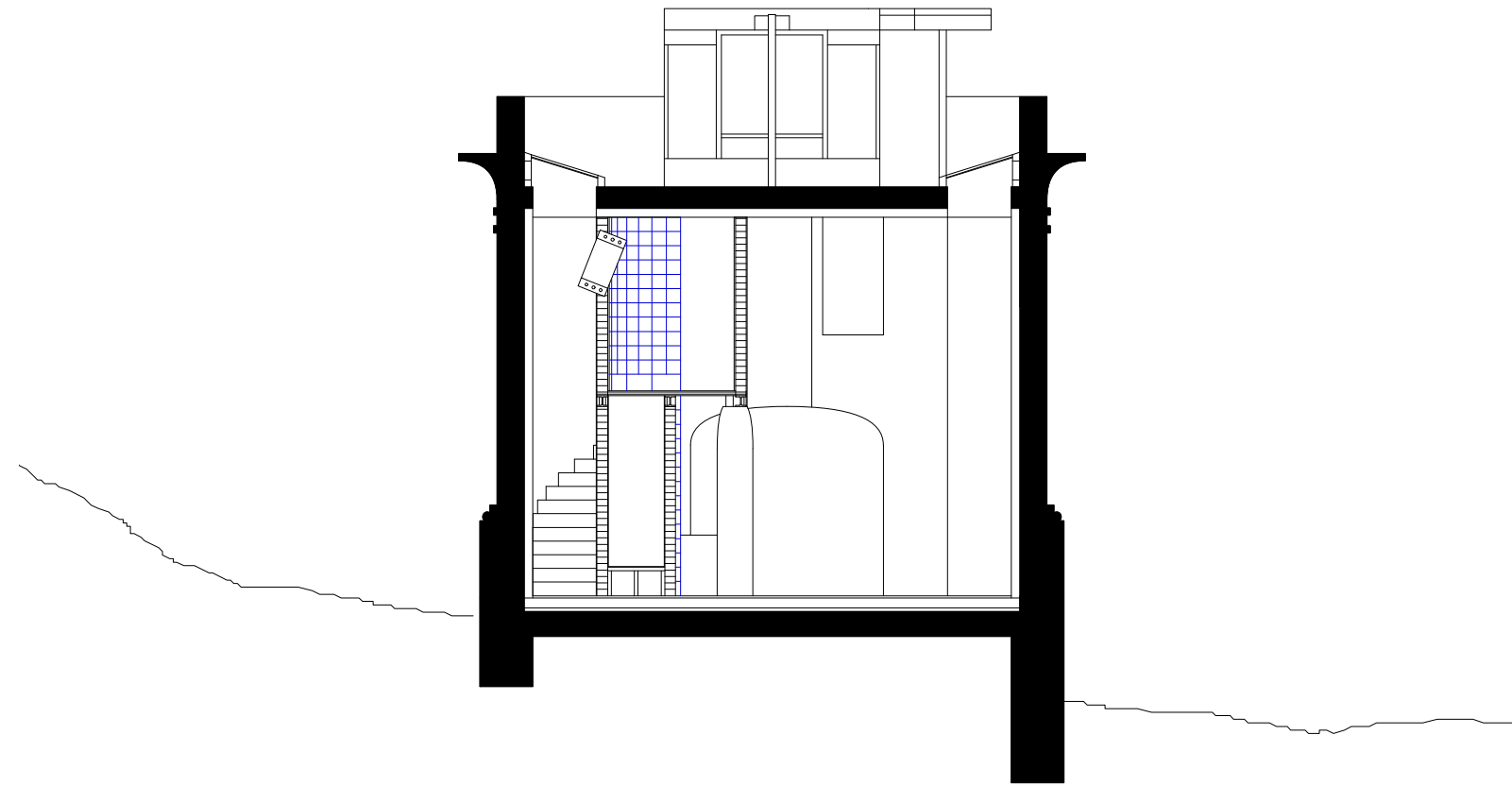
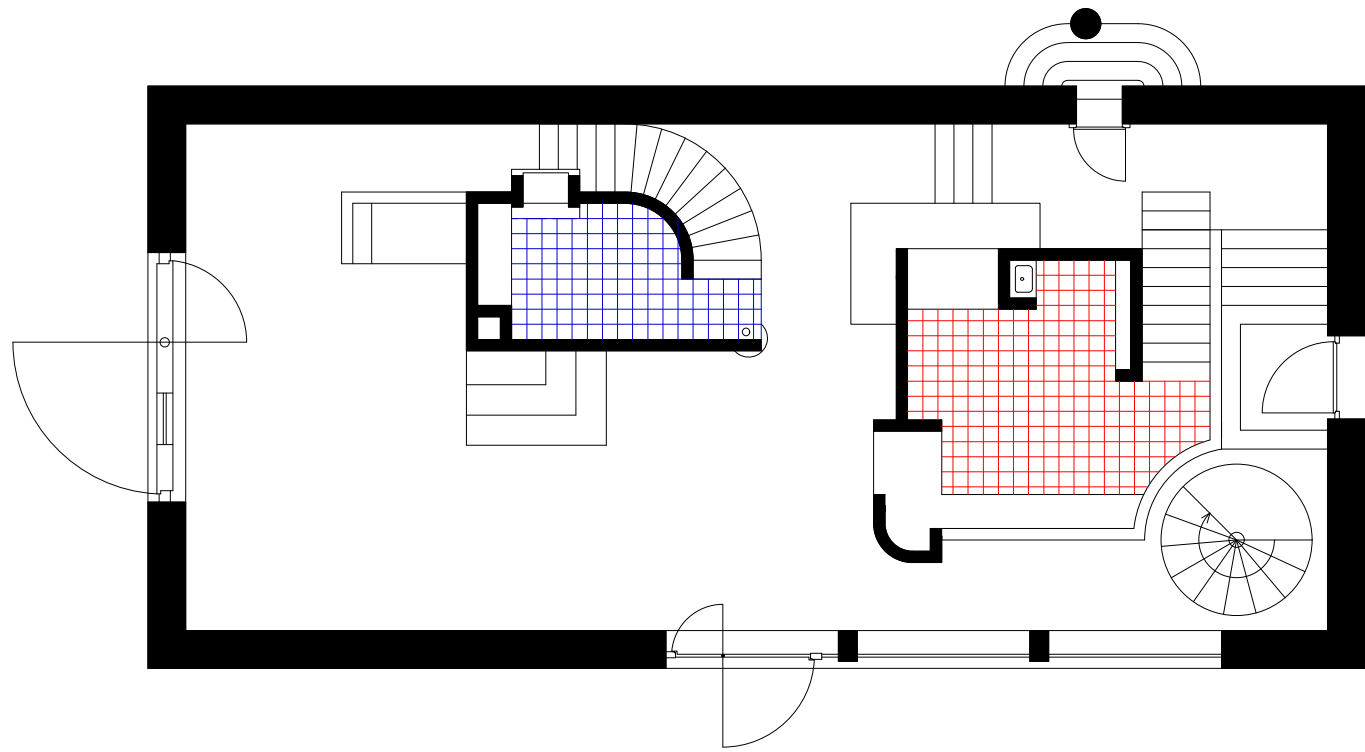

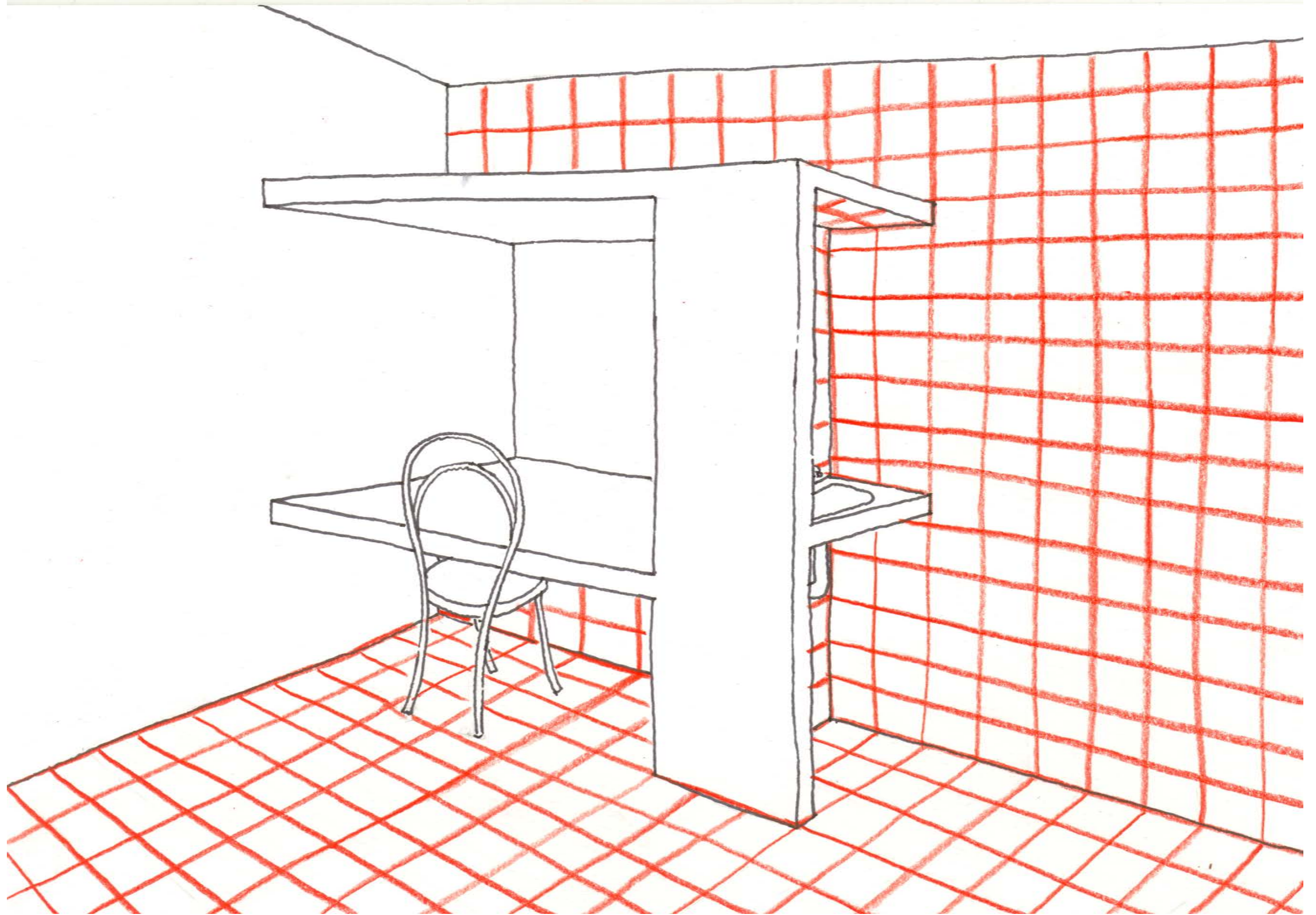

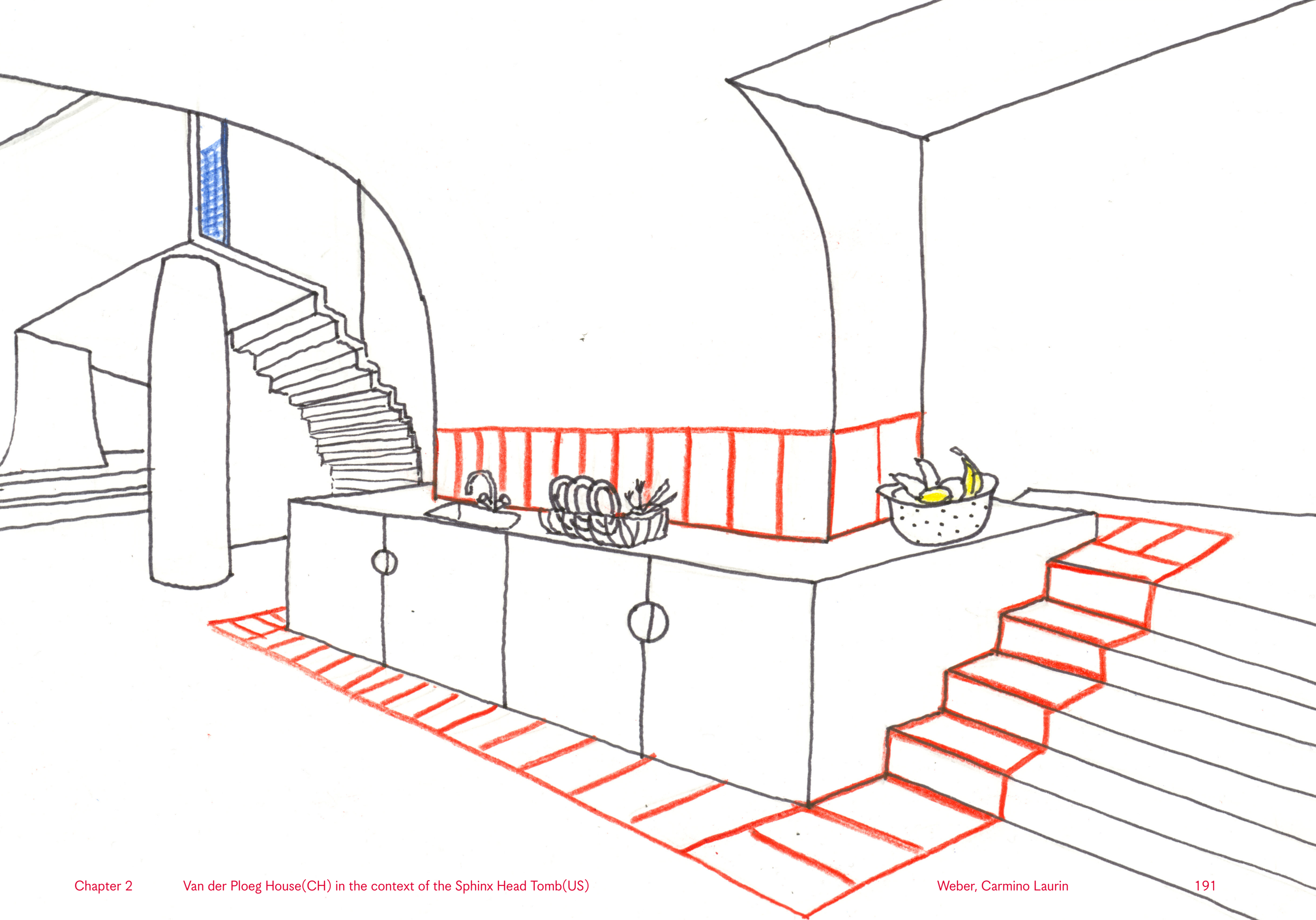



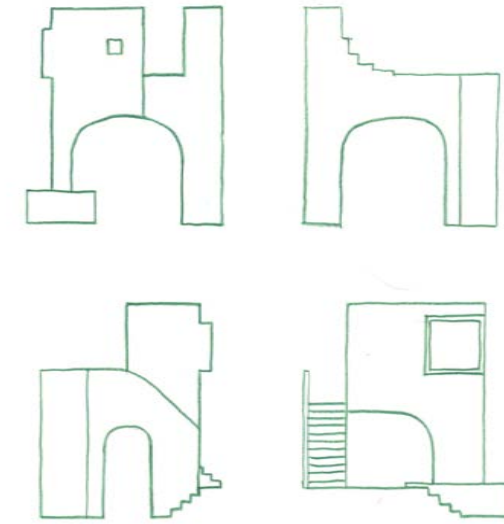
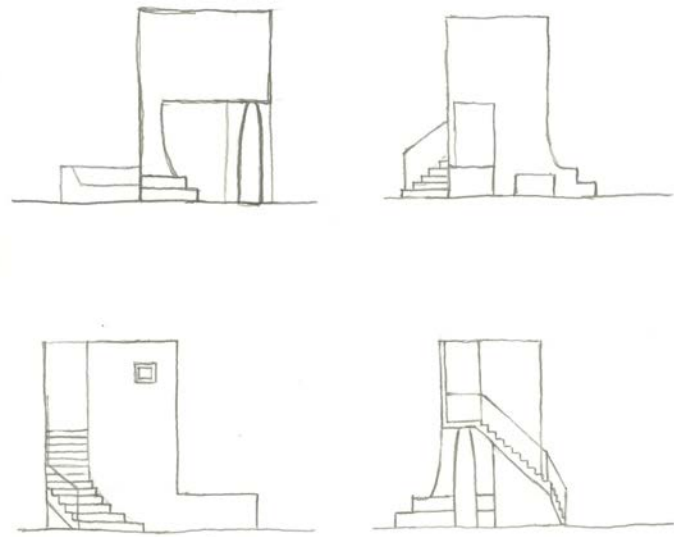

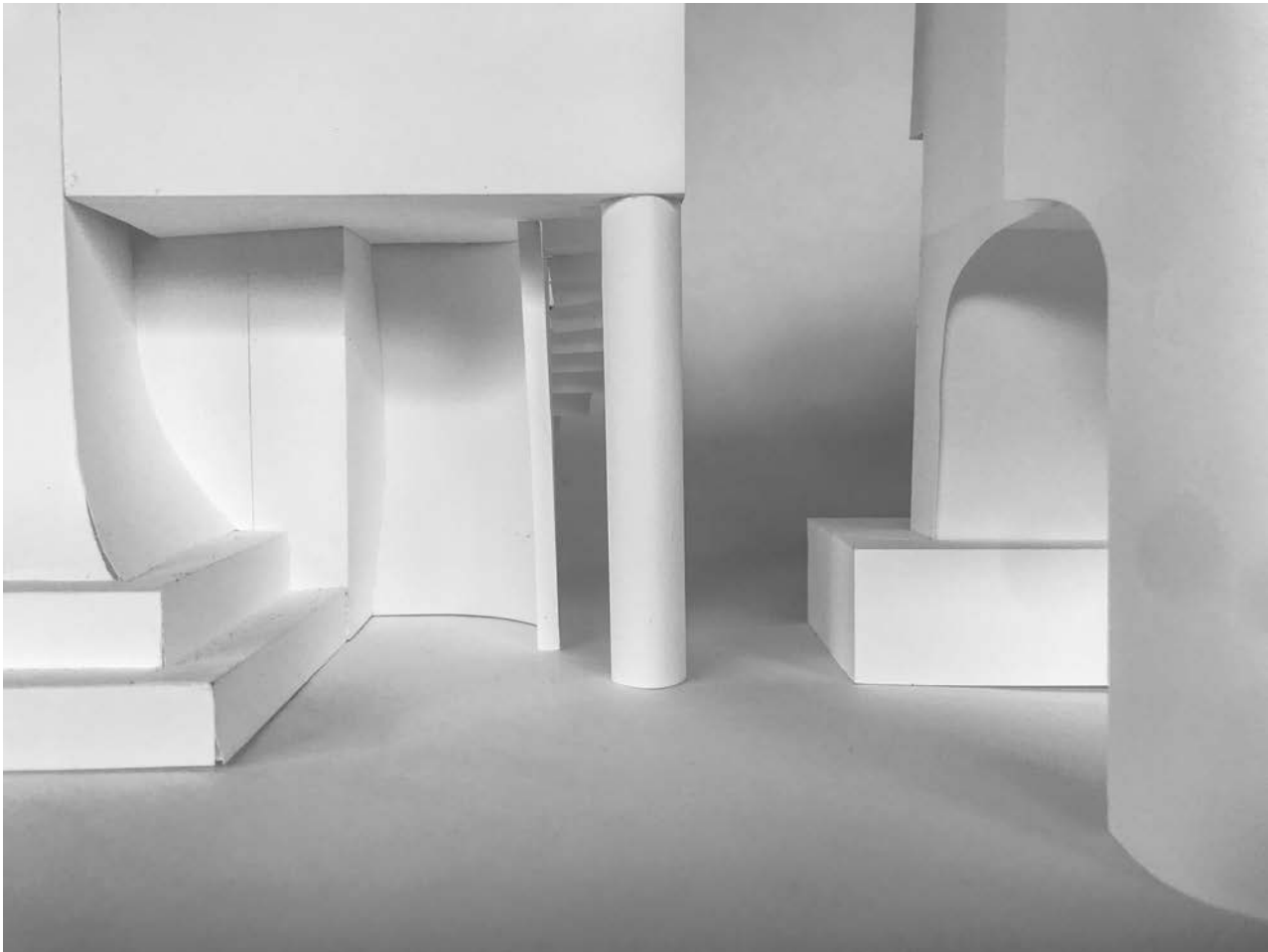

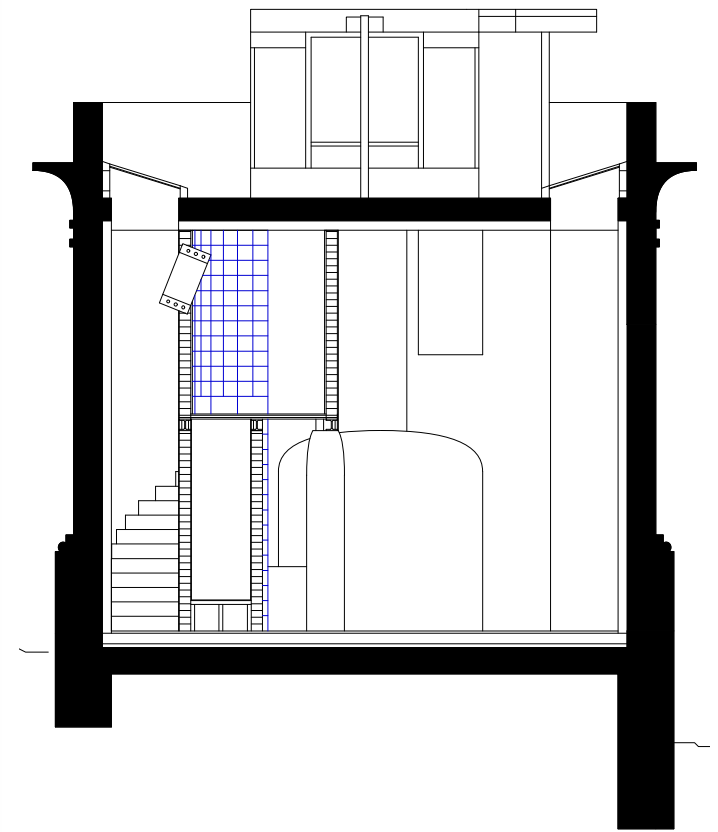
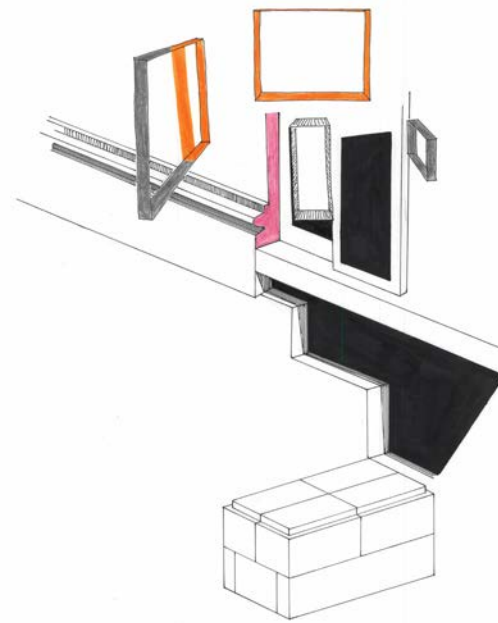
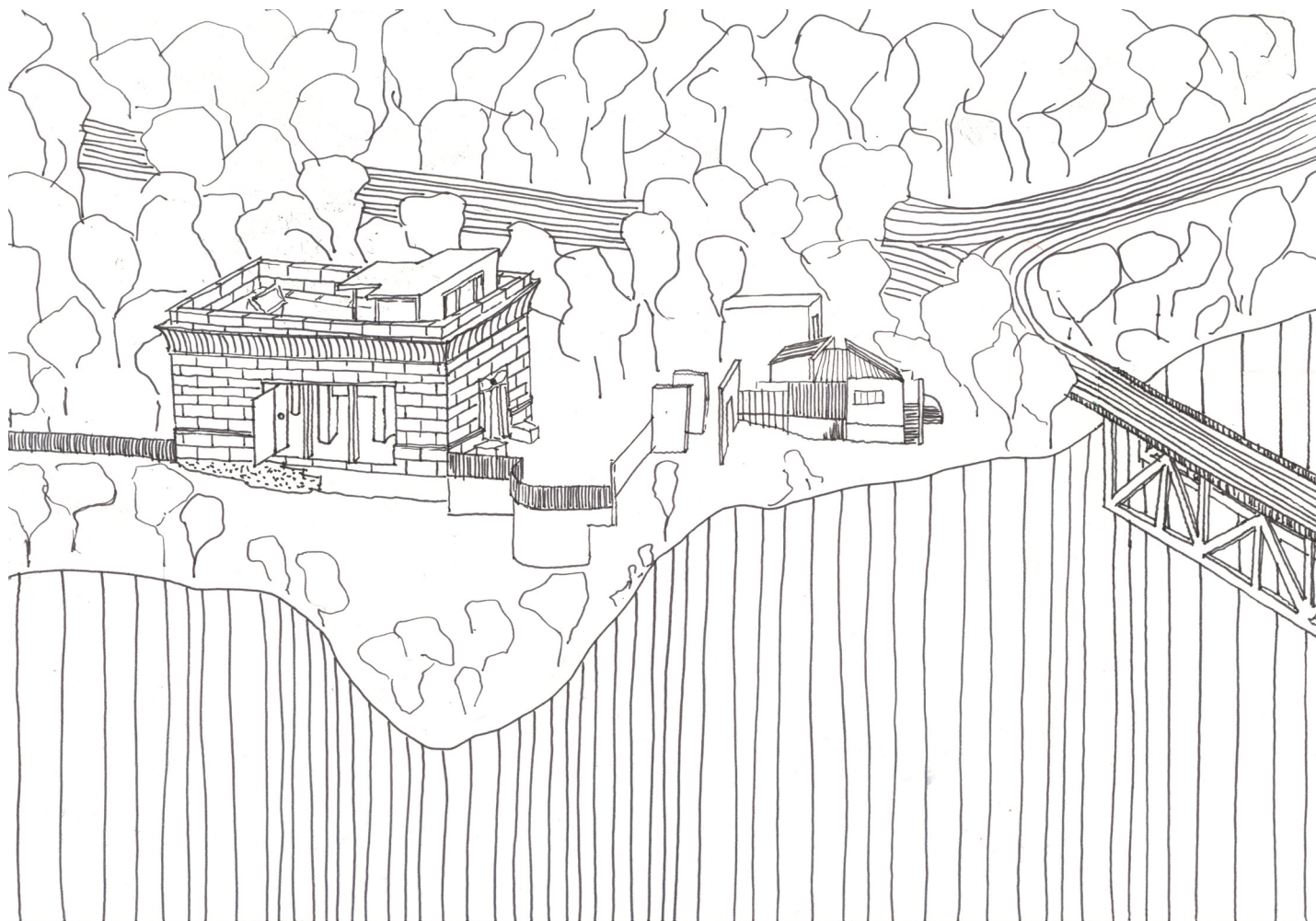
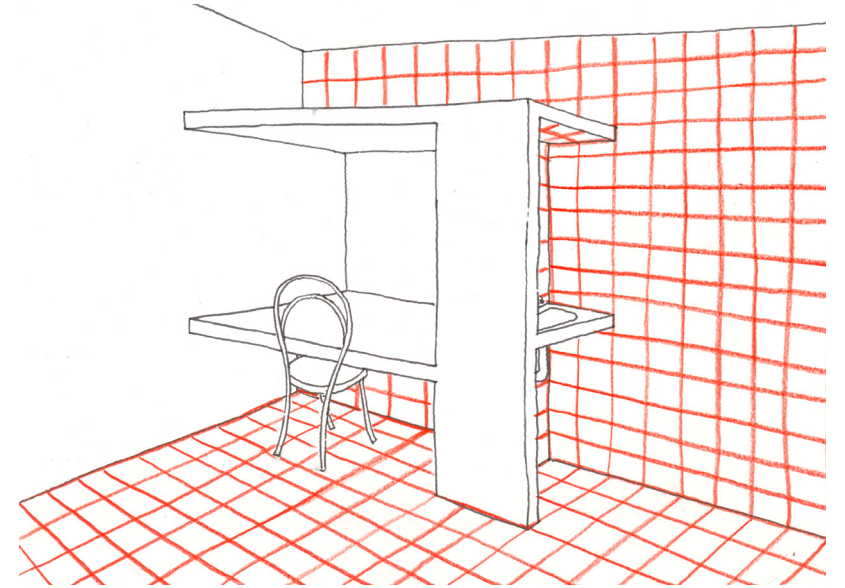
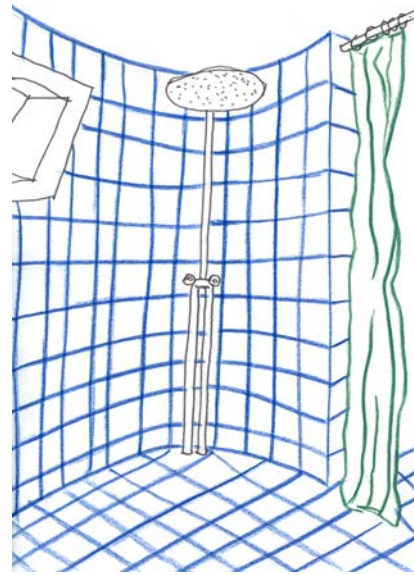
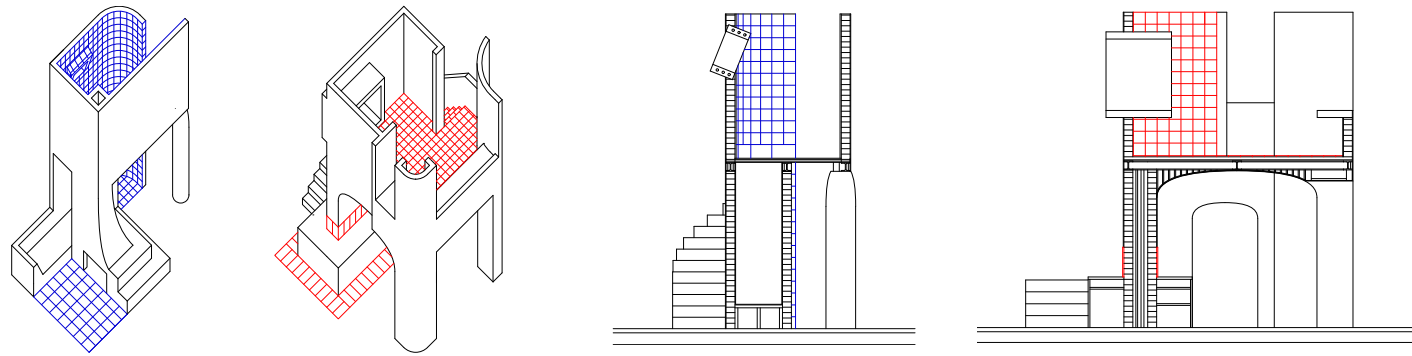
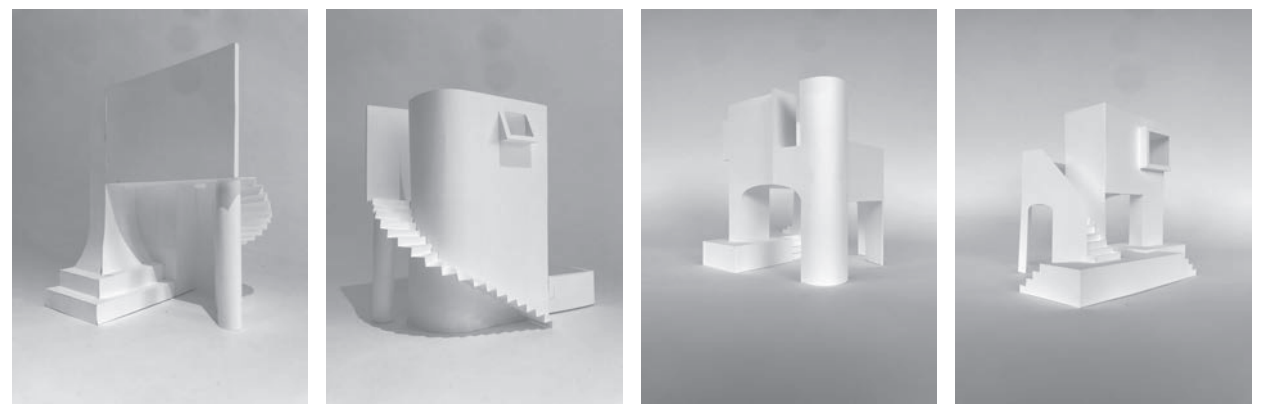
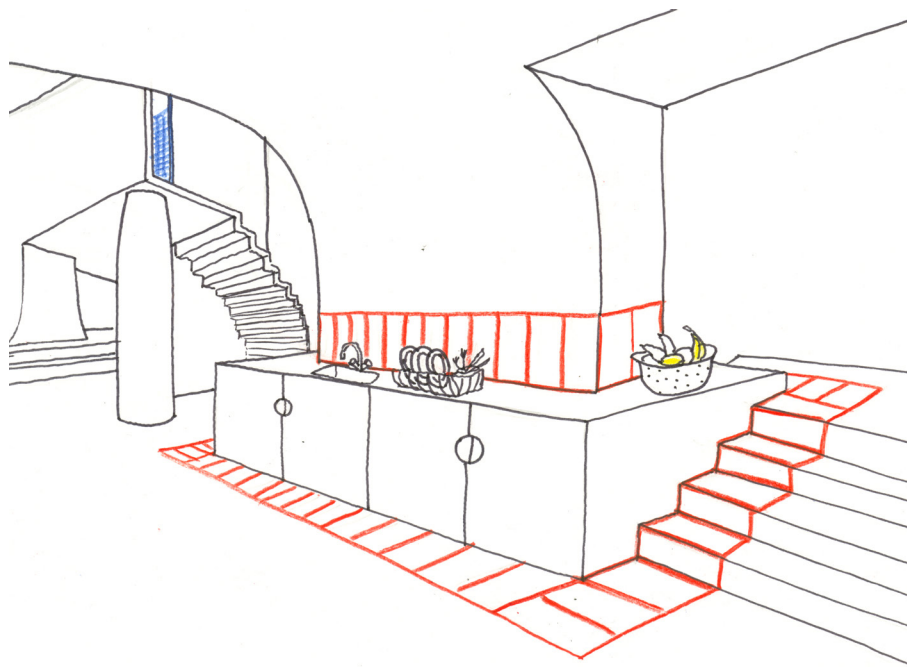

## Movement 2

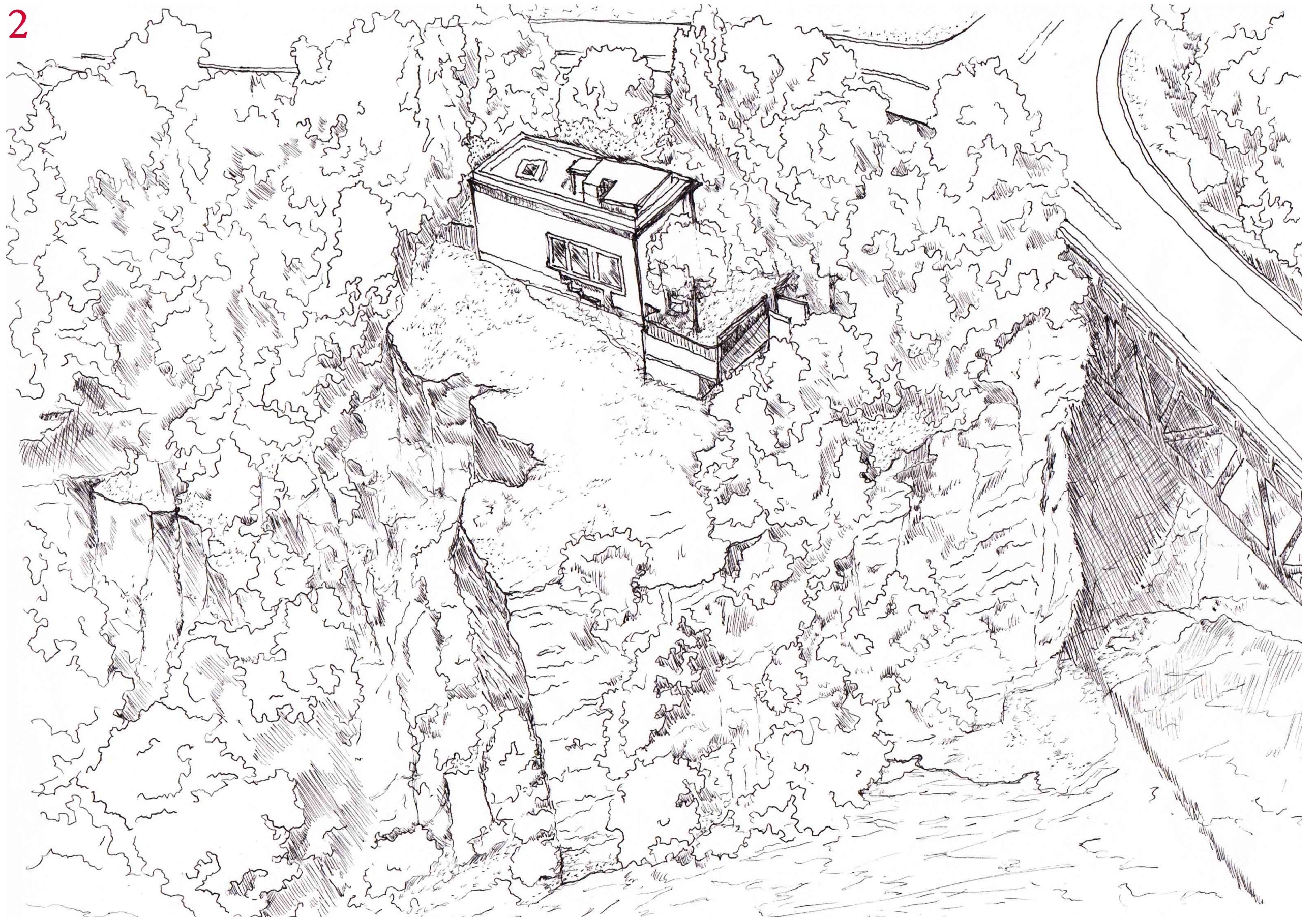

# Illusion

**Fences. Yours and mine. Security.**

**Long lines wrapped around a piece of land. Clearly separating, guiding you where to walk, where to be.**

**This lady is isolating herself. The only weak point seems to be the door.**

**I decided to have another fence. I know it is a constraint but knowing they are there is giving me peace.**

**A feeling of freedom away from society:**

**Perception,  
expectations,  
illusions,  
confusion,  
astonishment.**

**I love mazes.**

**I love the idea of space as**

**acquaintances, as friends, as lovers.**

**I love to imagine my entrance like**

**a maze. Friends will pass through**

**quickly, strangers will arrive a little**

**later.**

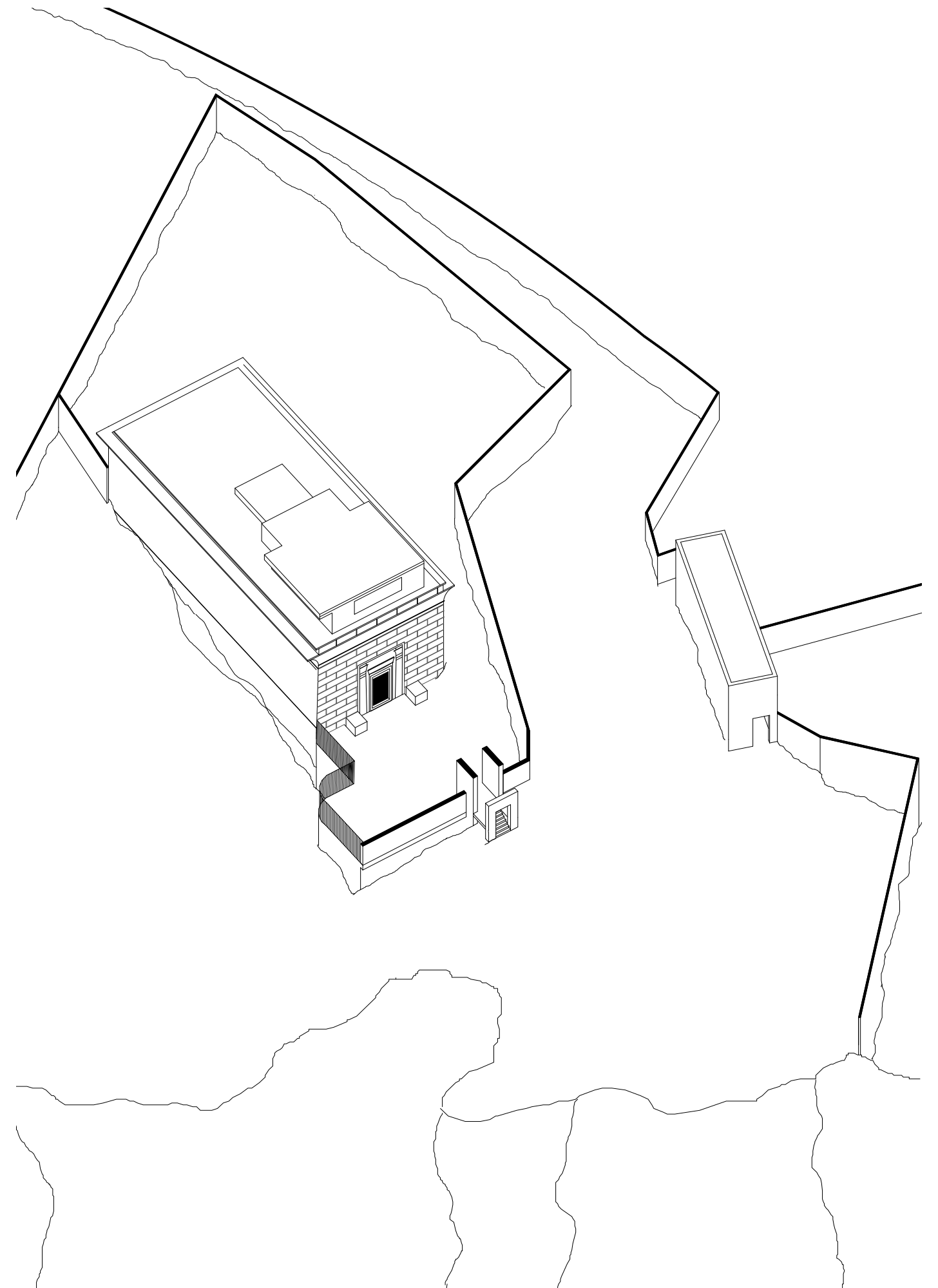

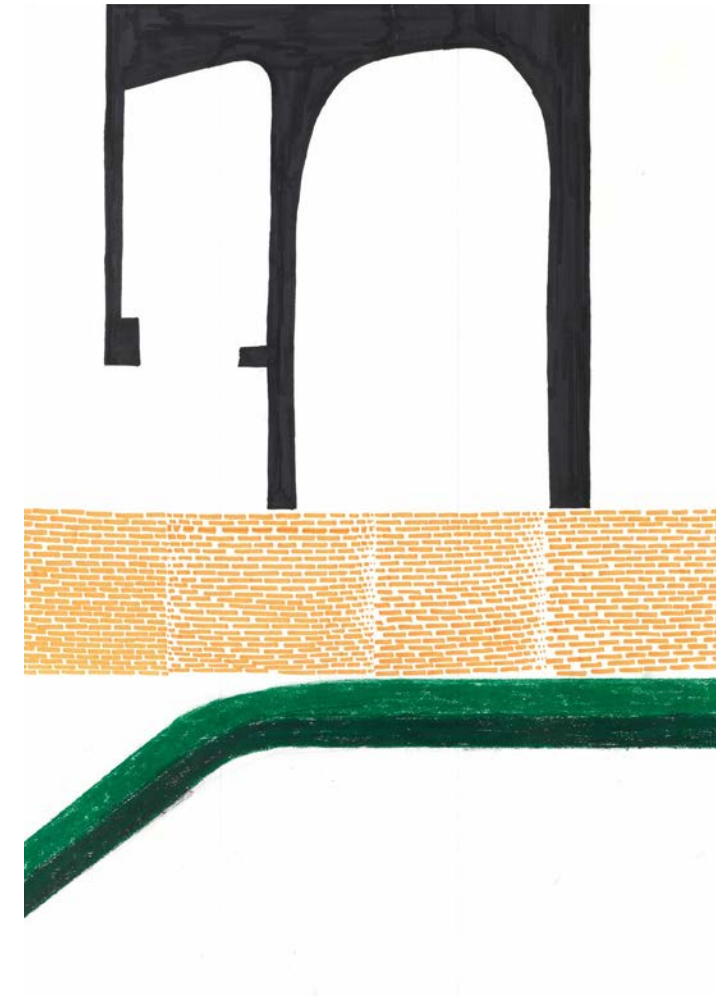

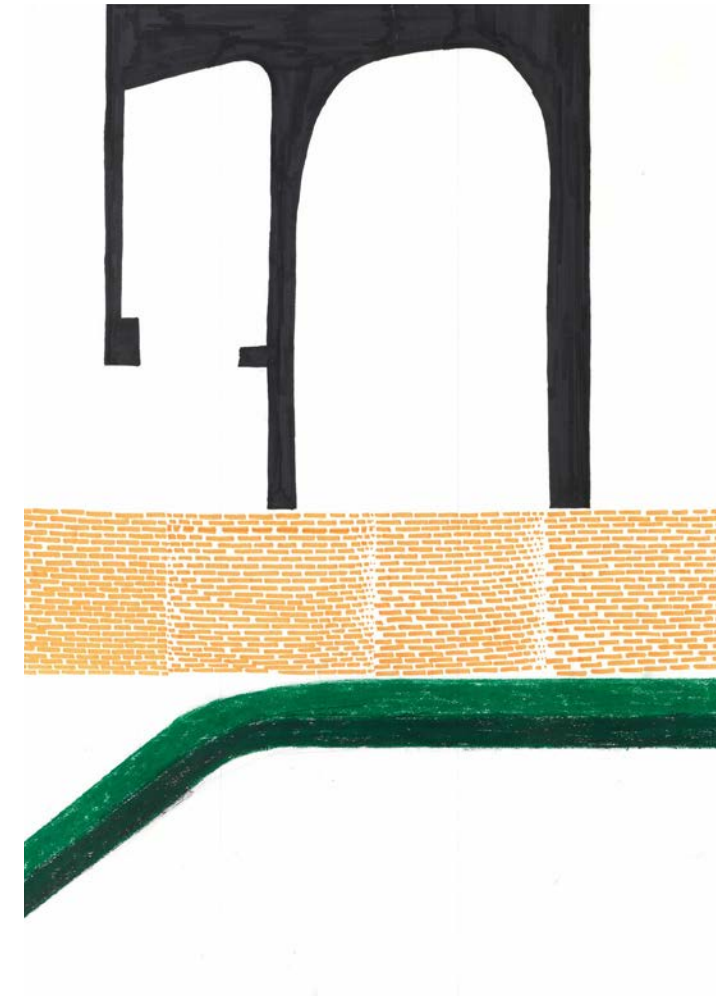

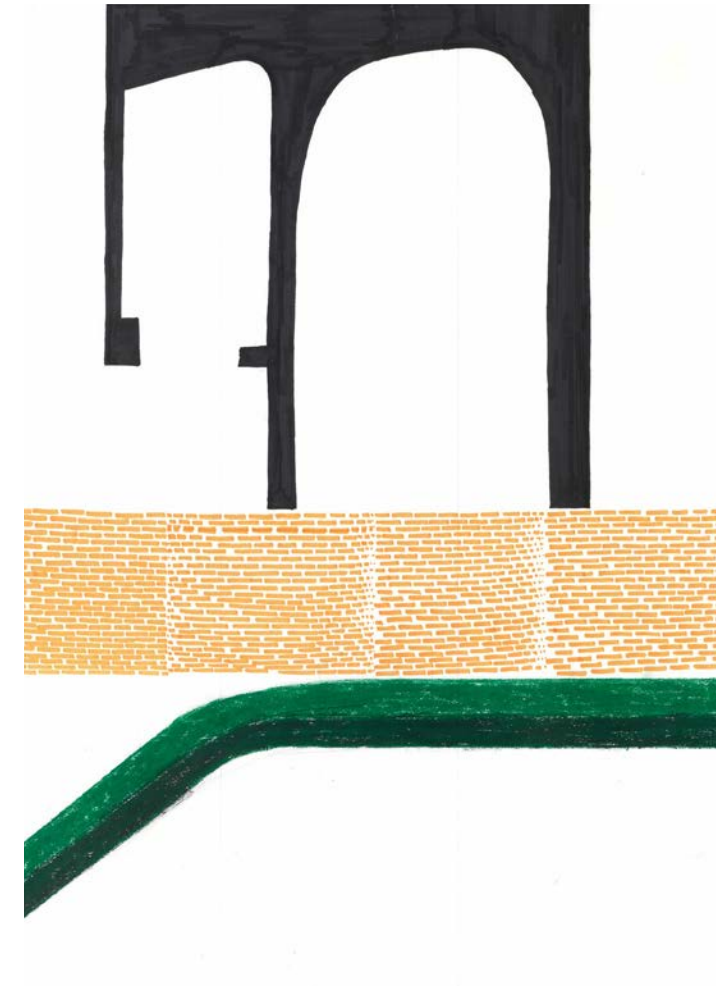
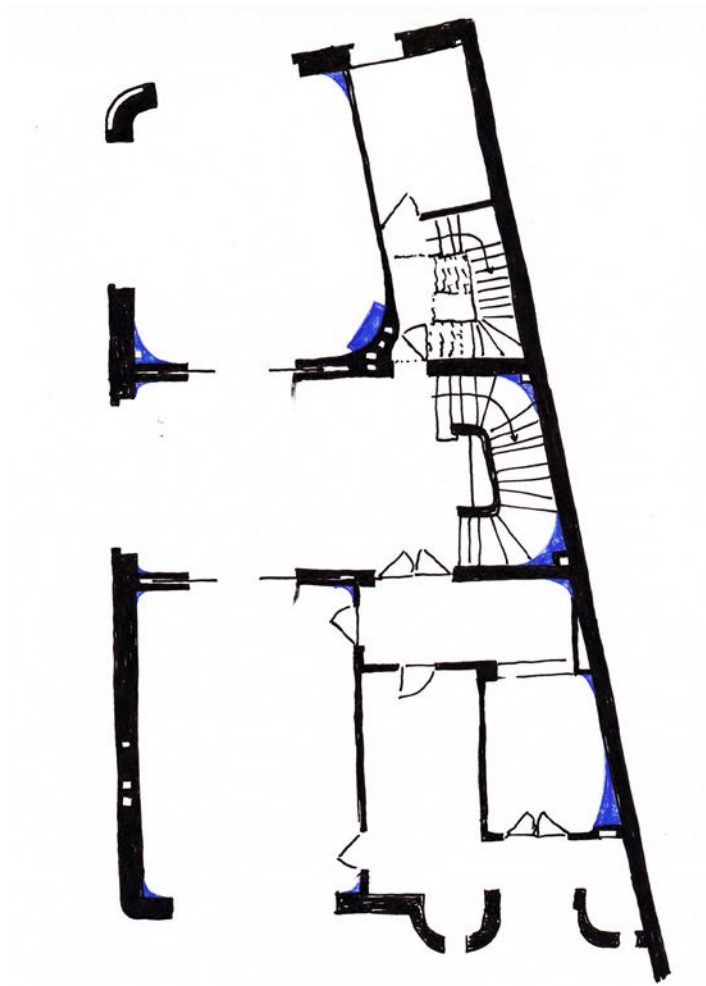



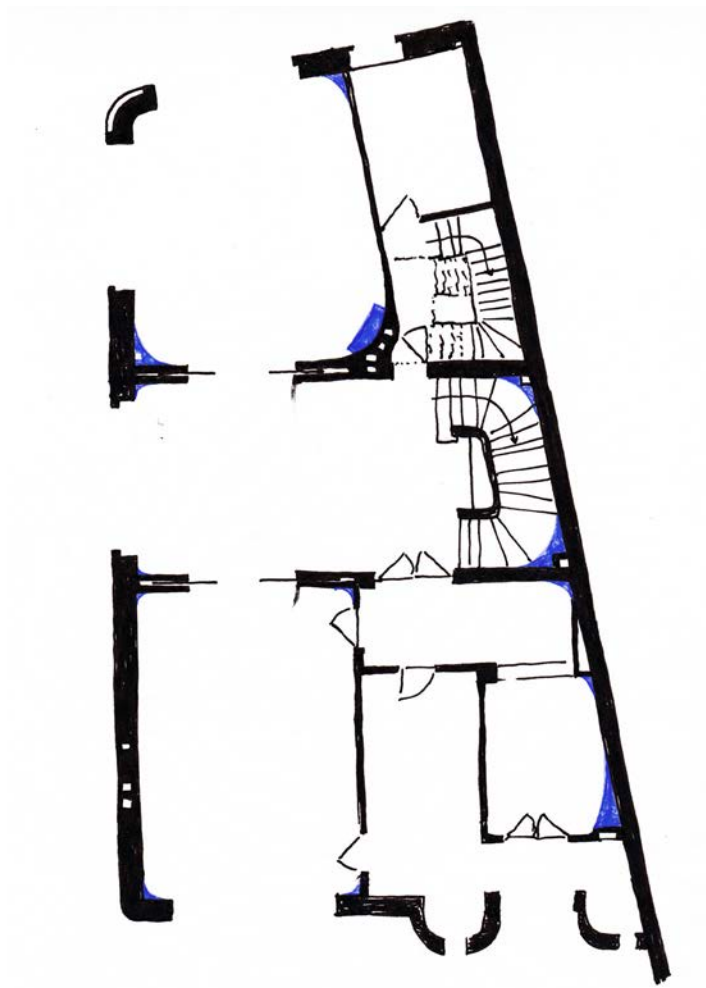

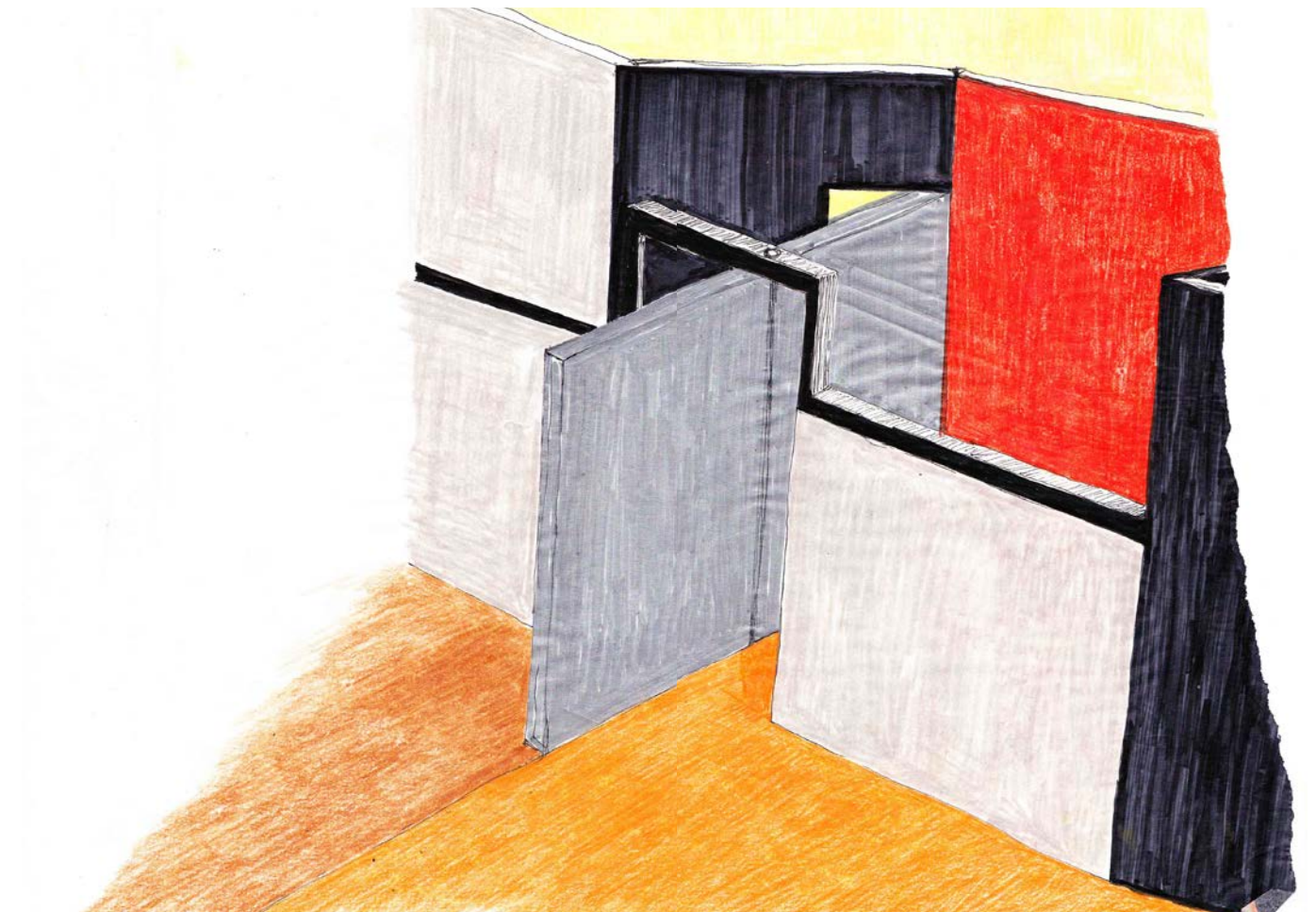
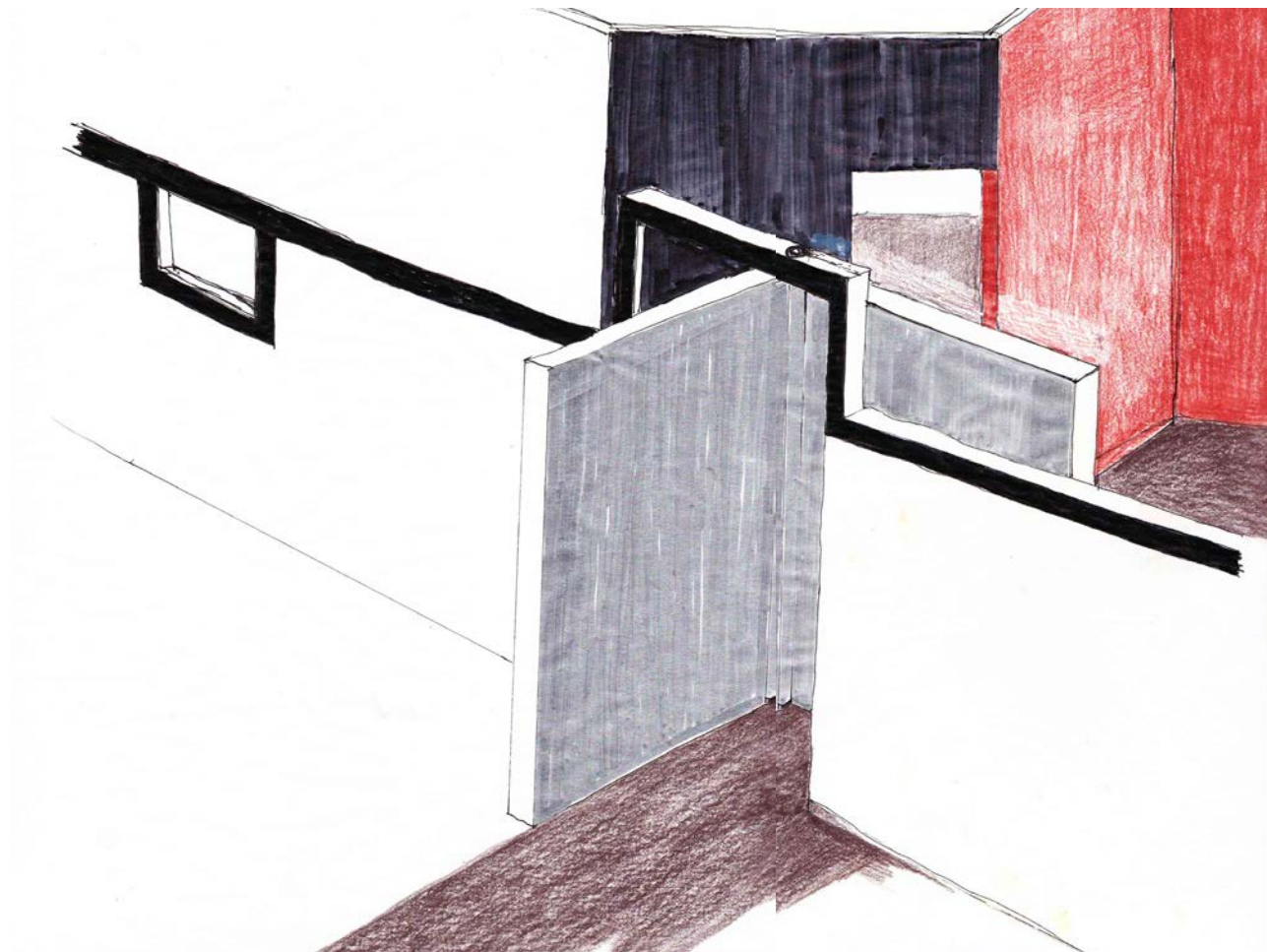

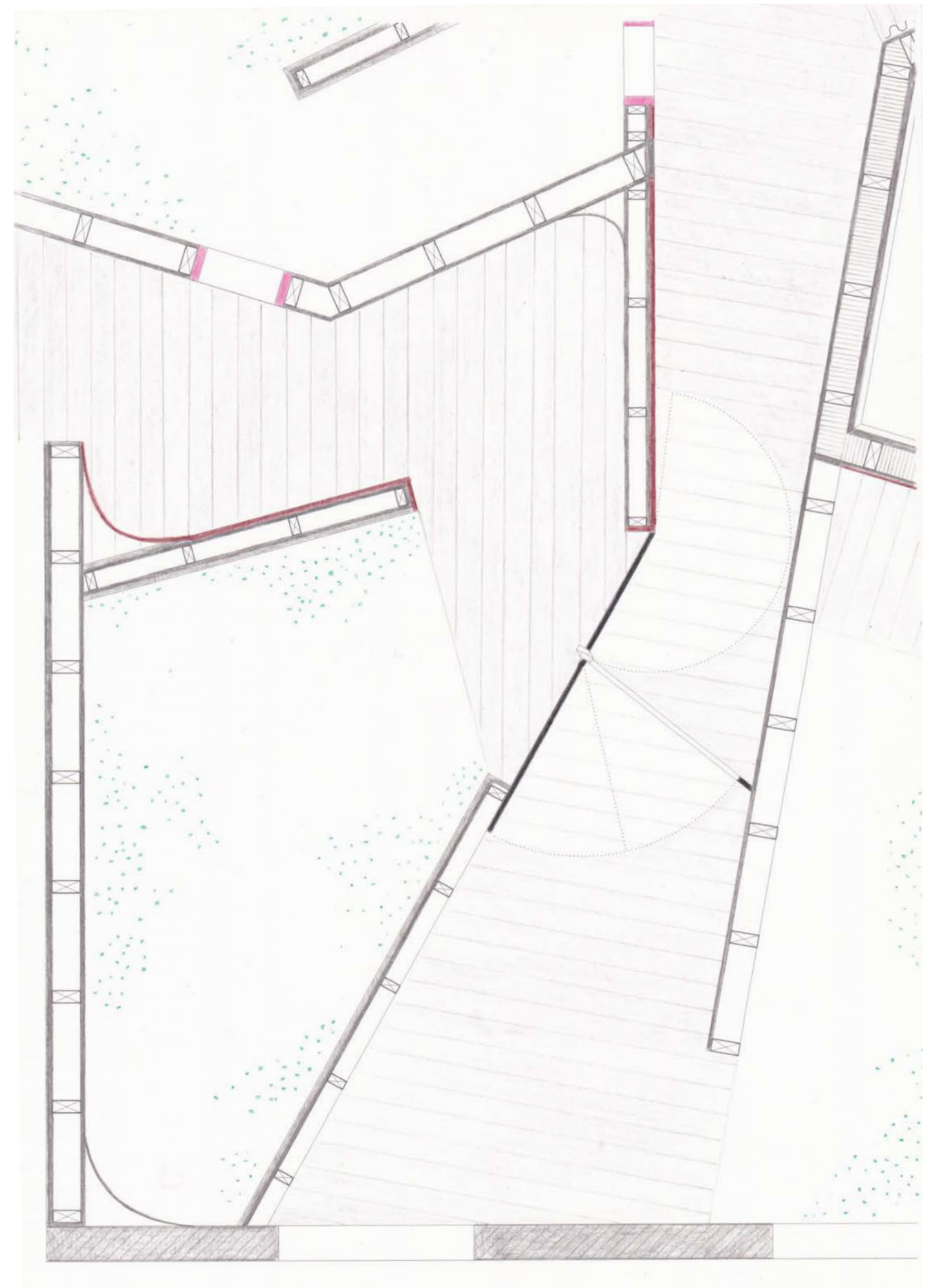
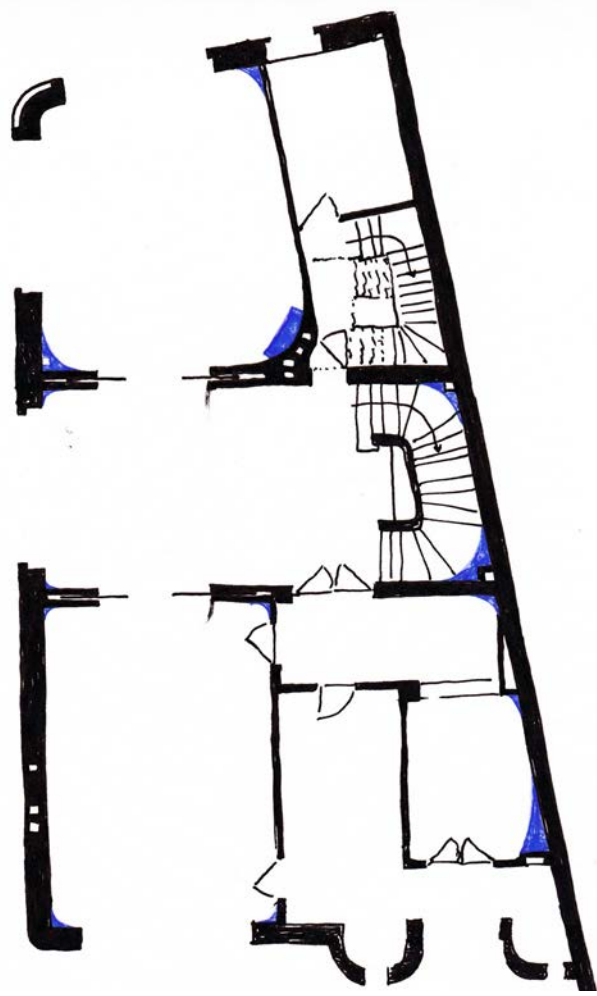



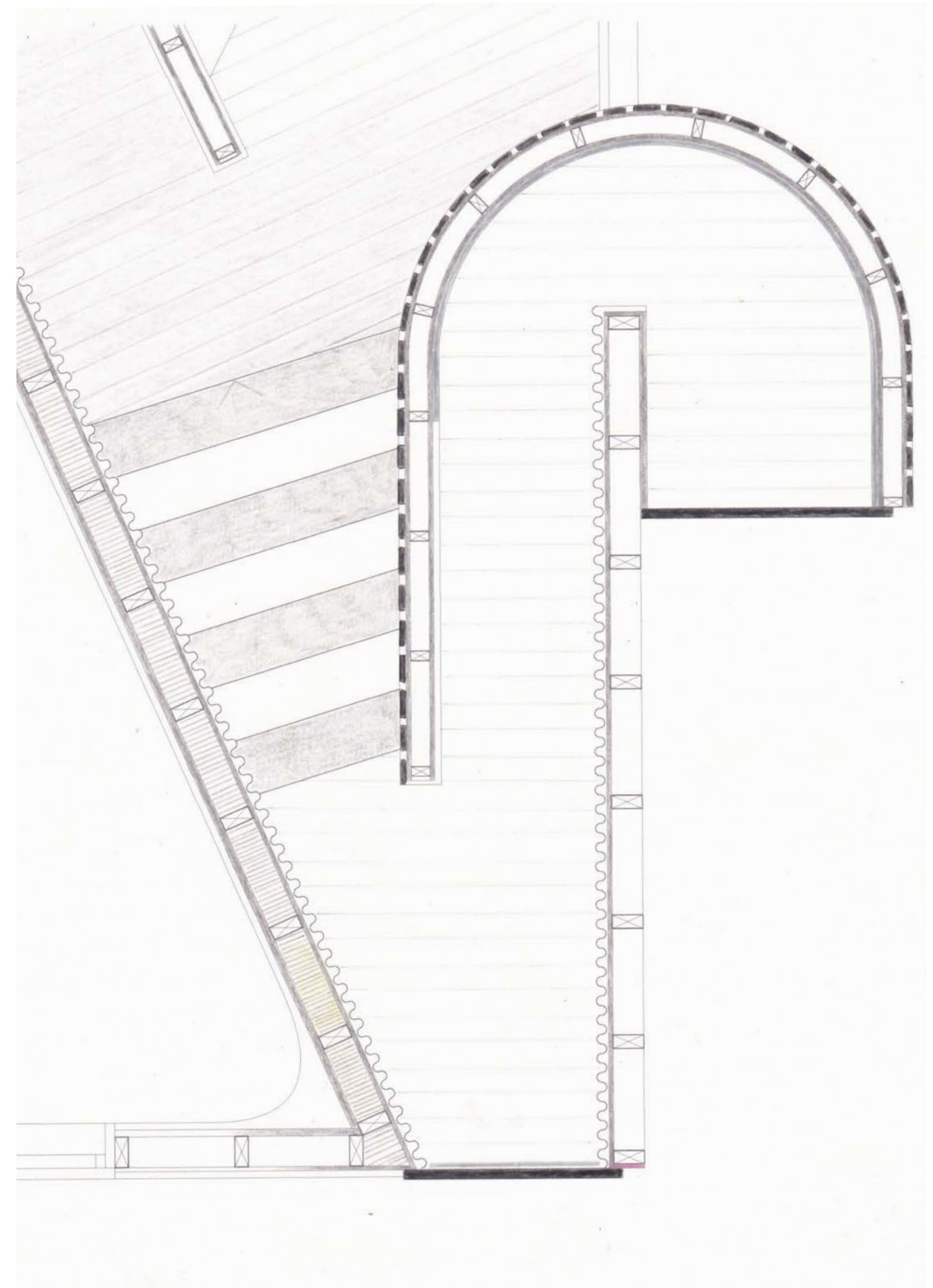
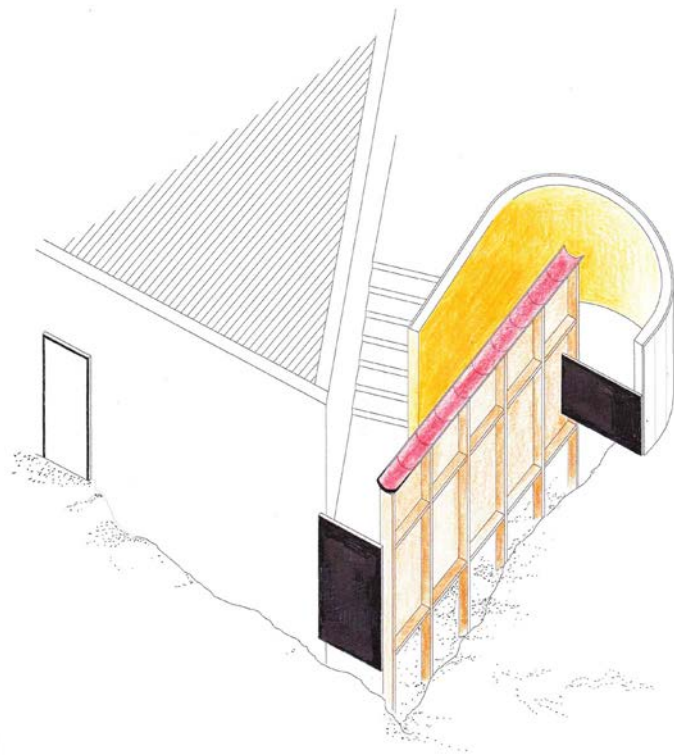

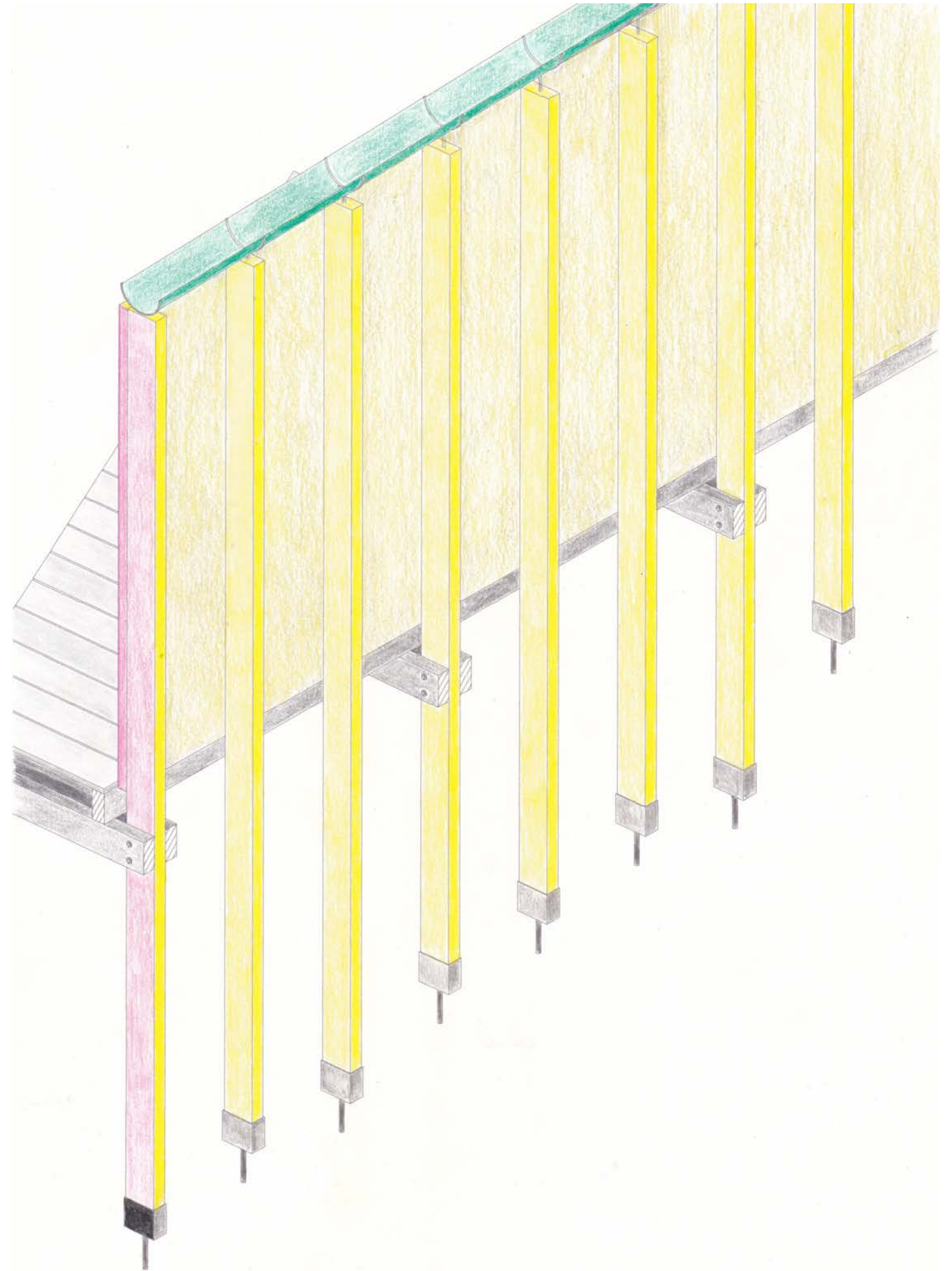
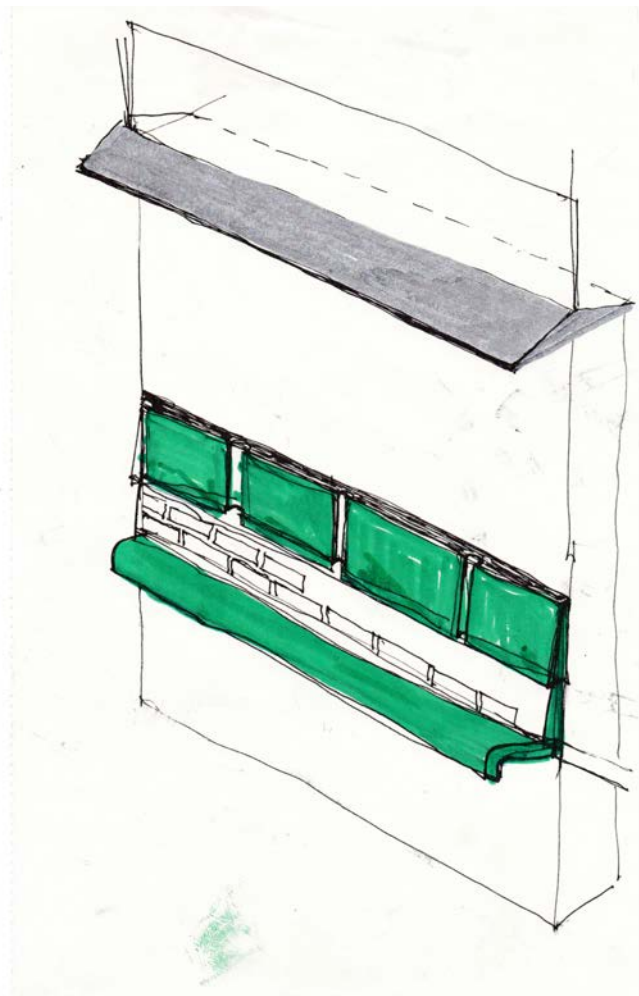
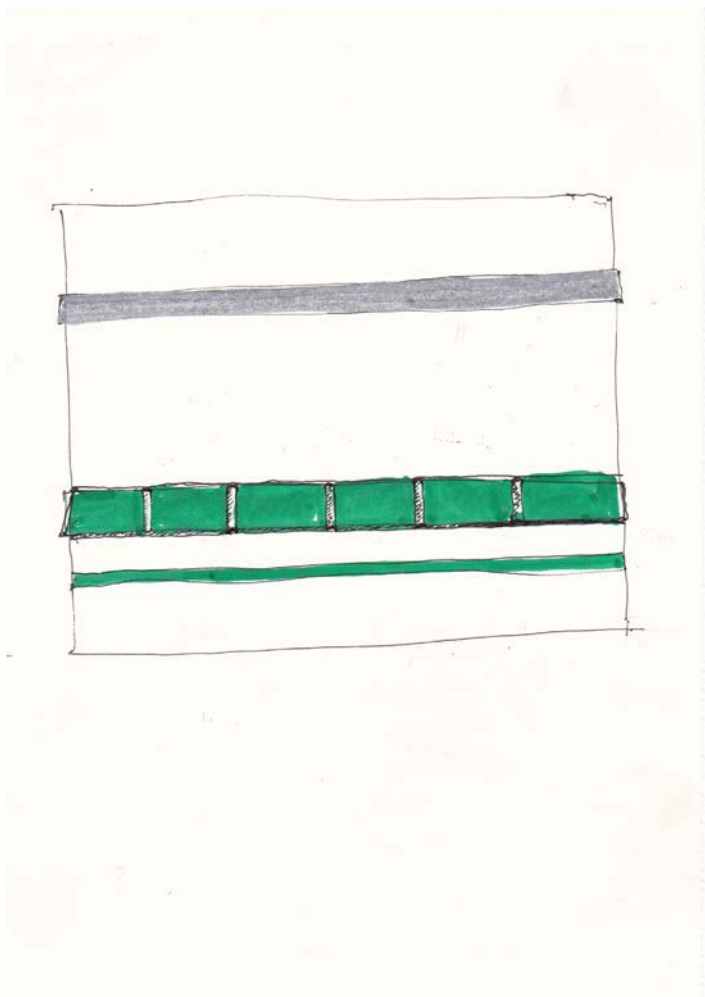

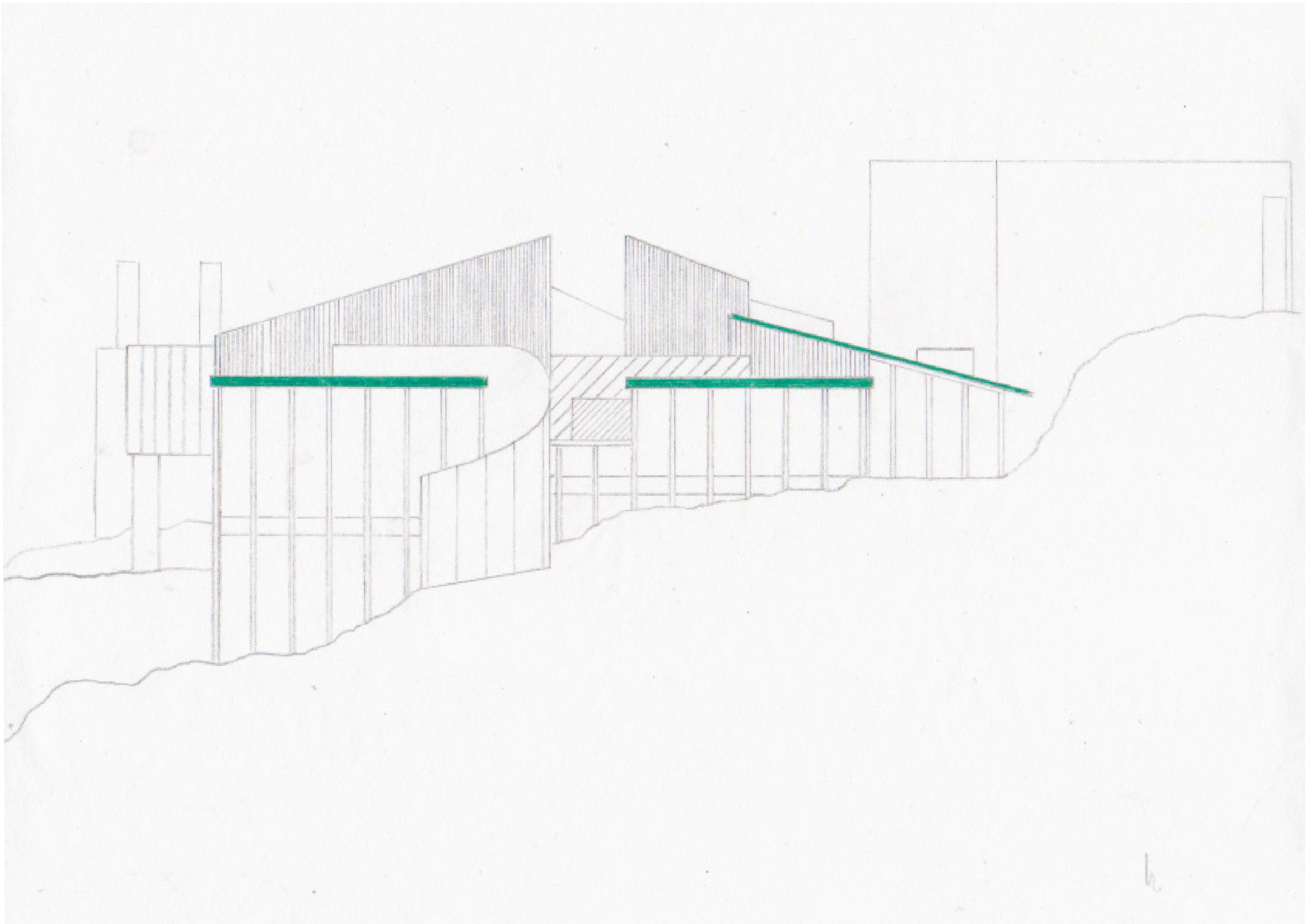

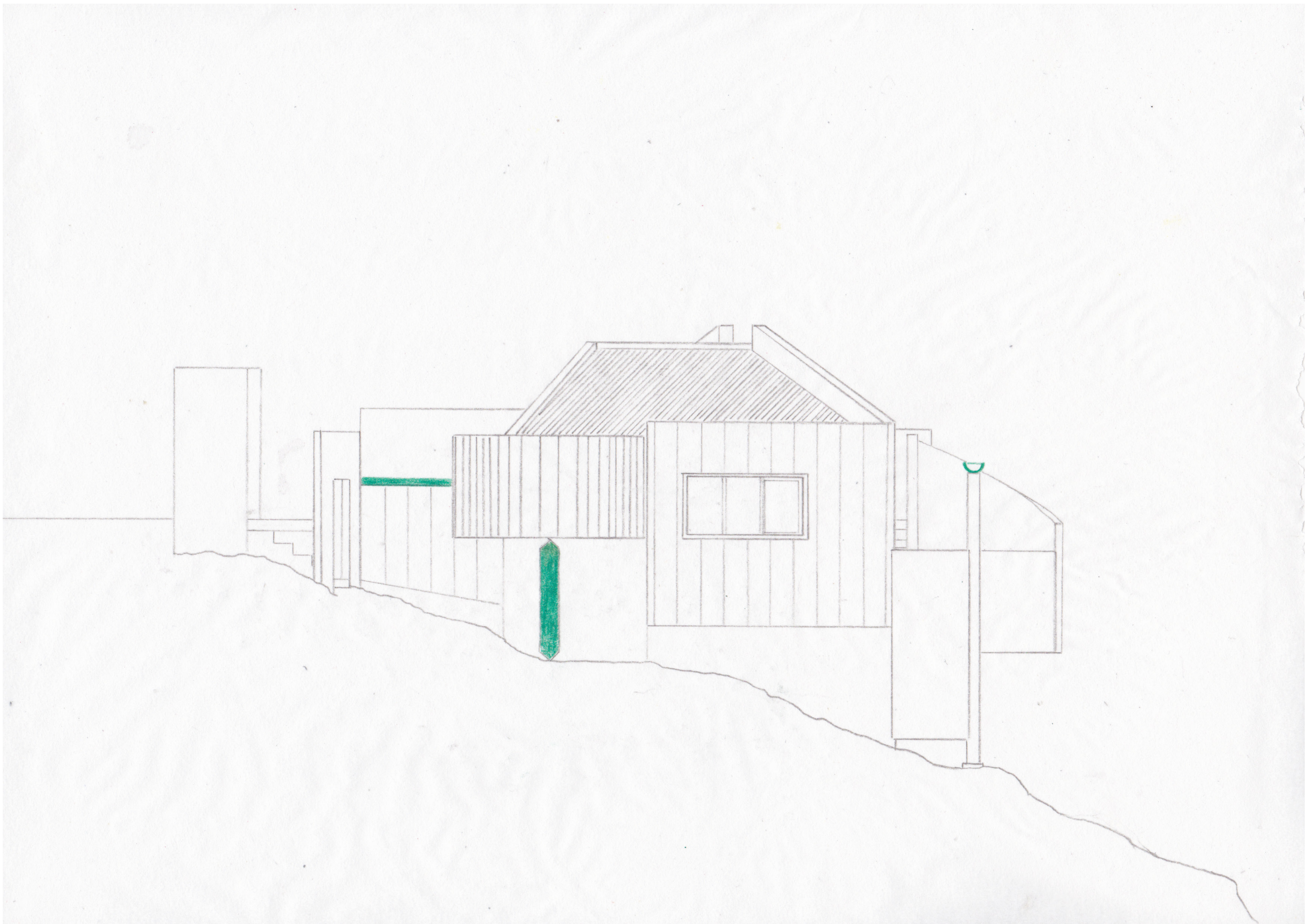



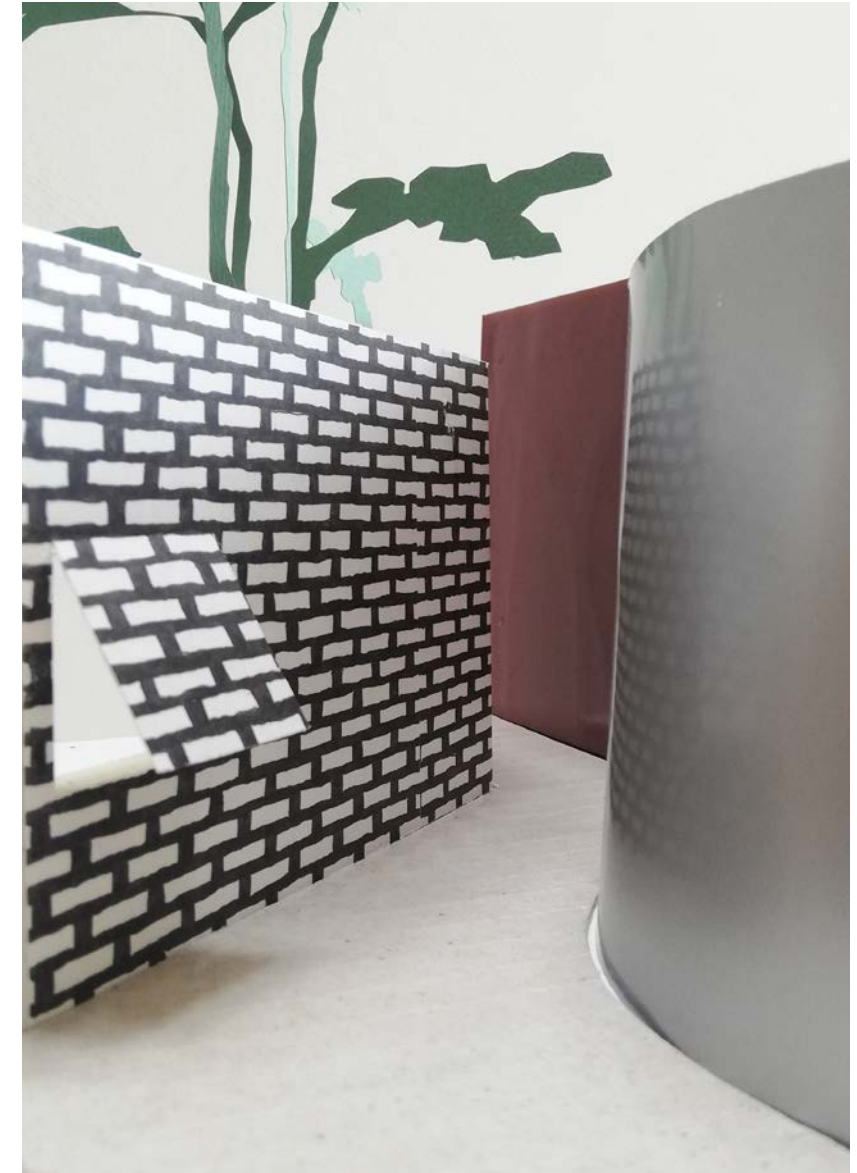

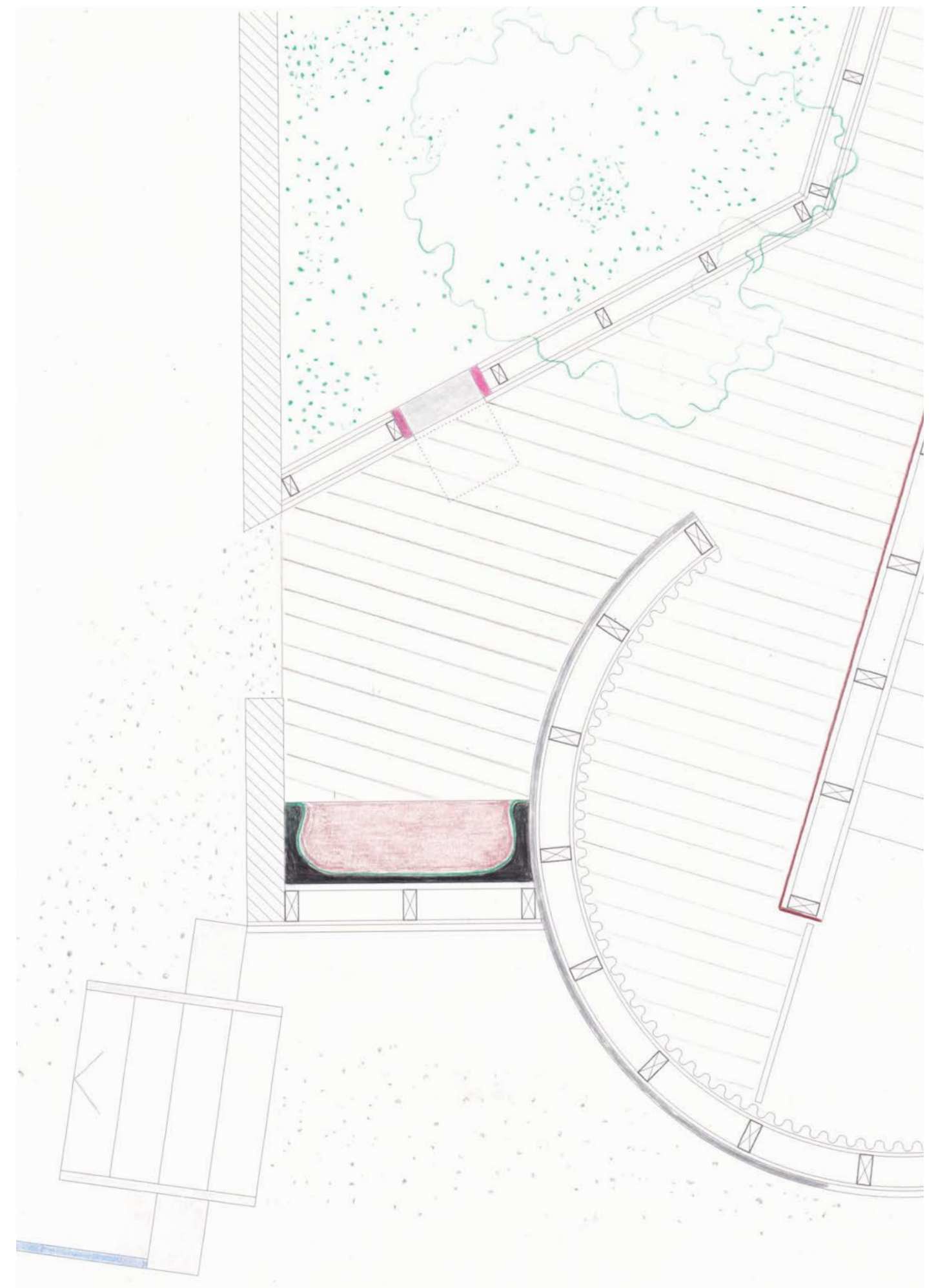
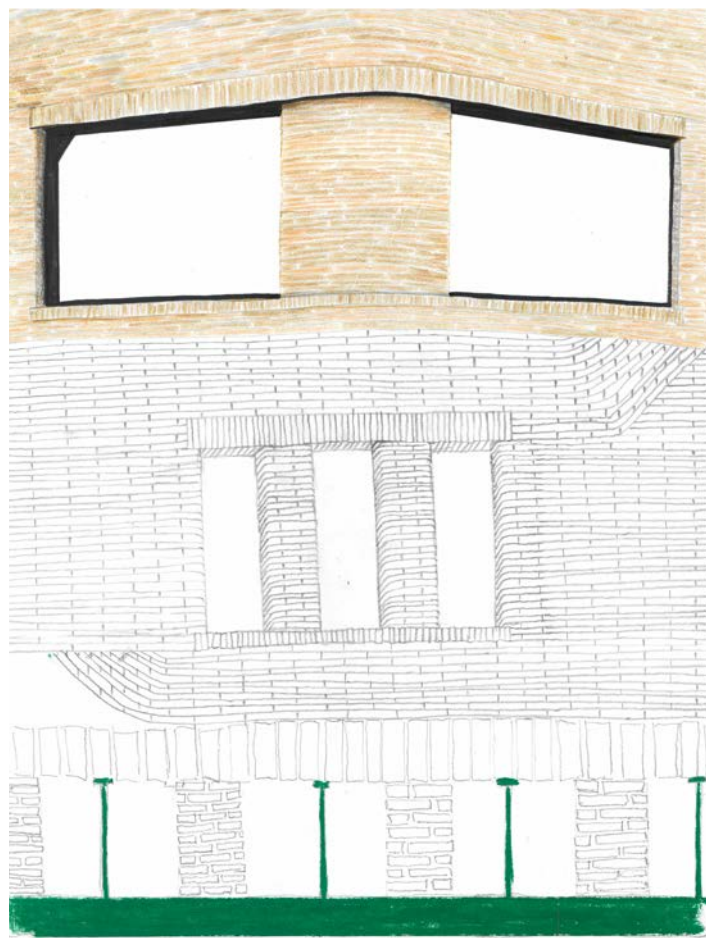

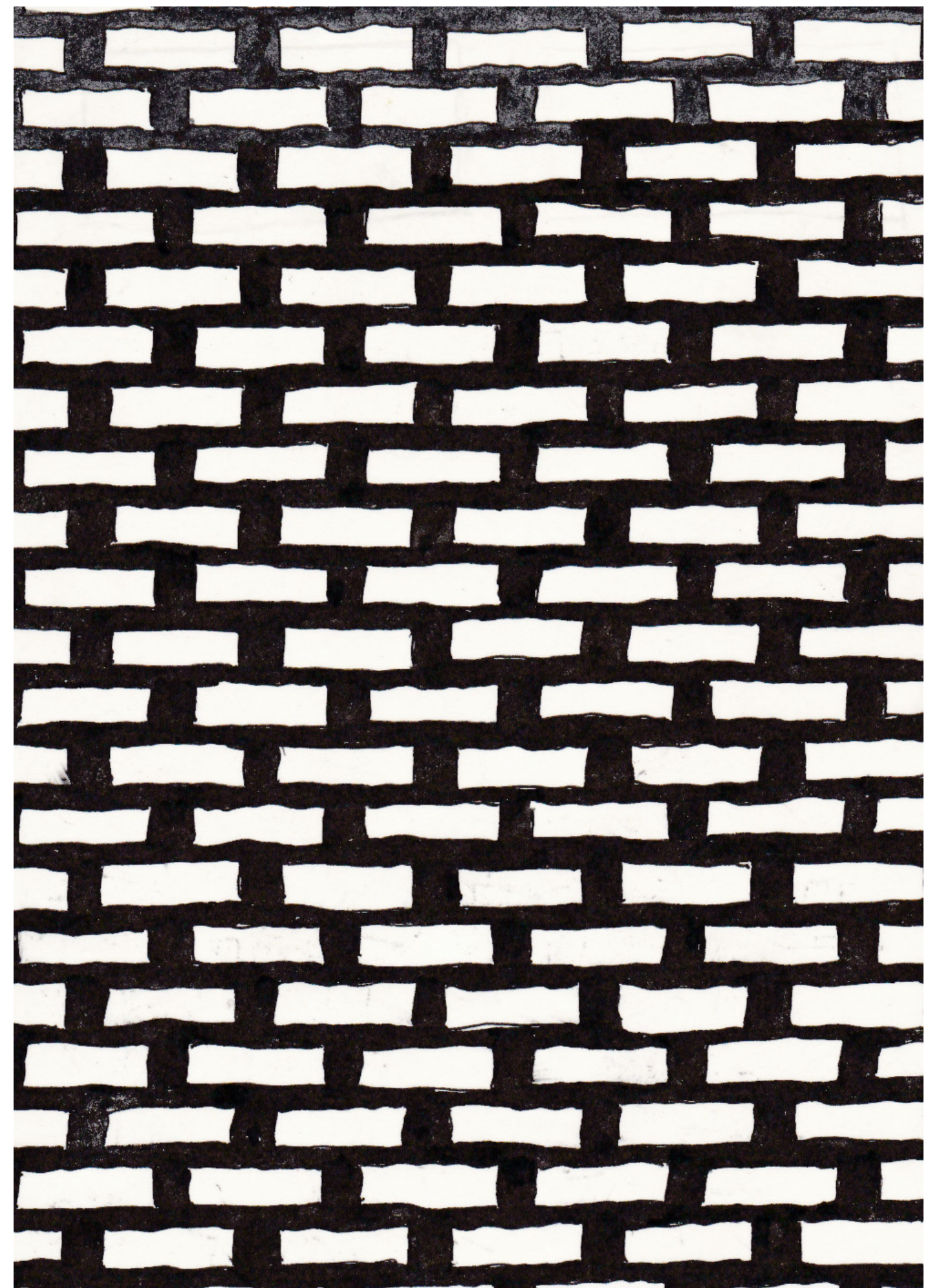

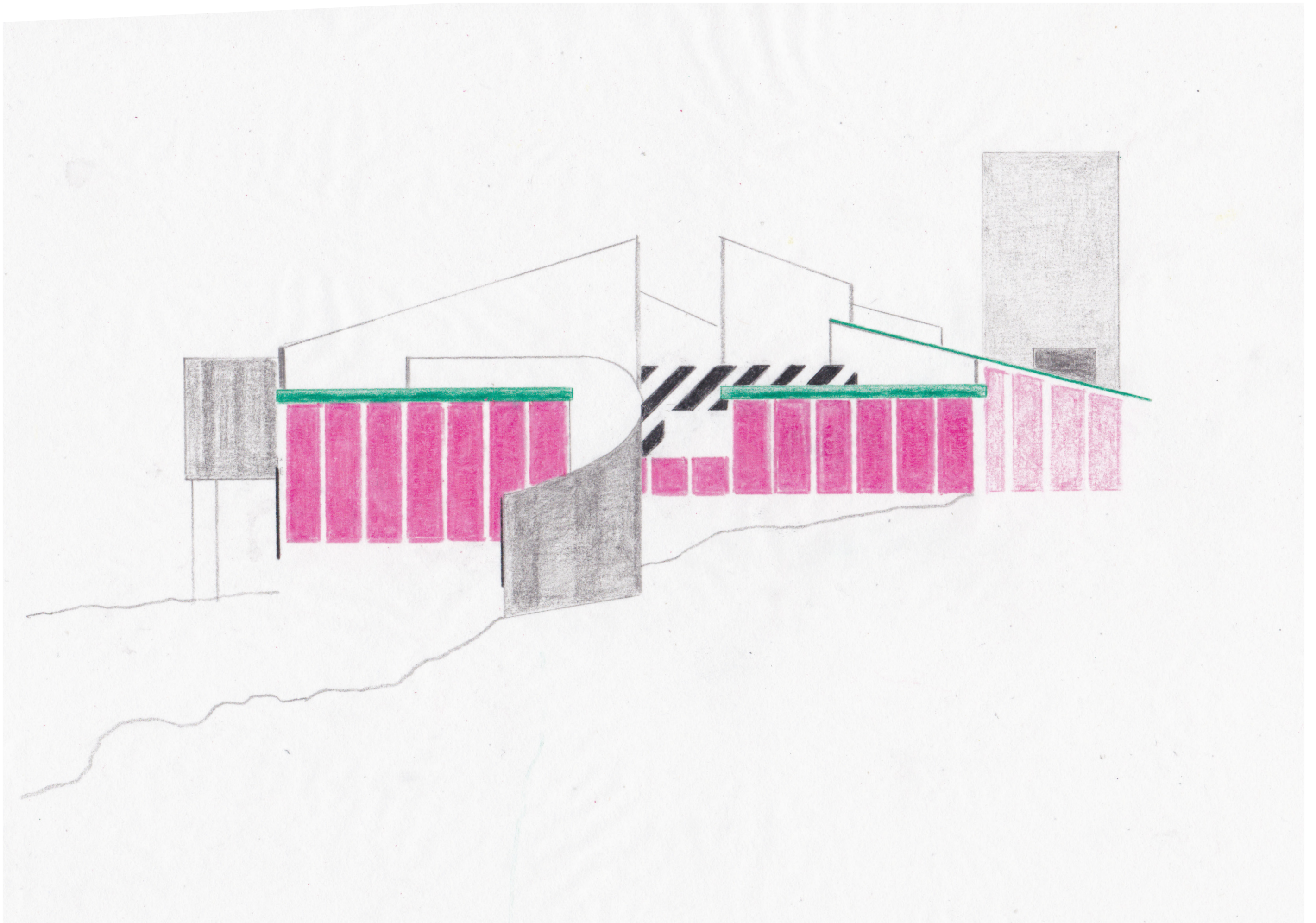

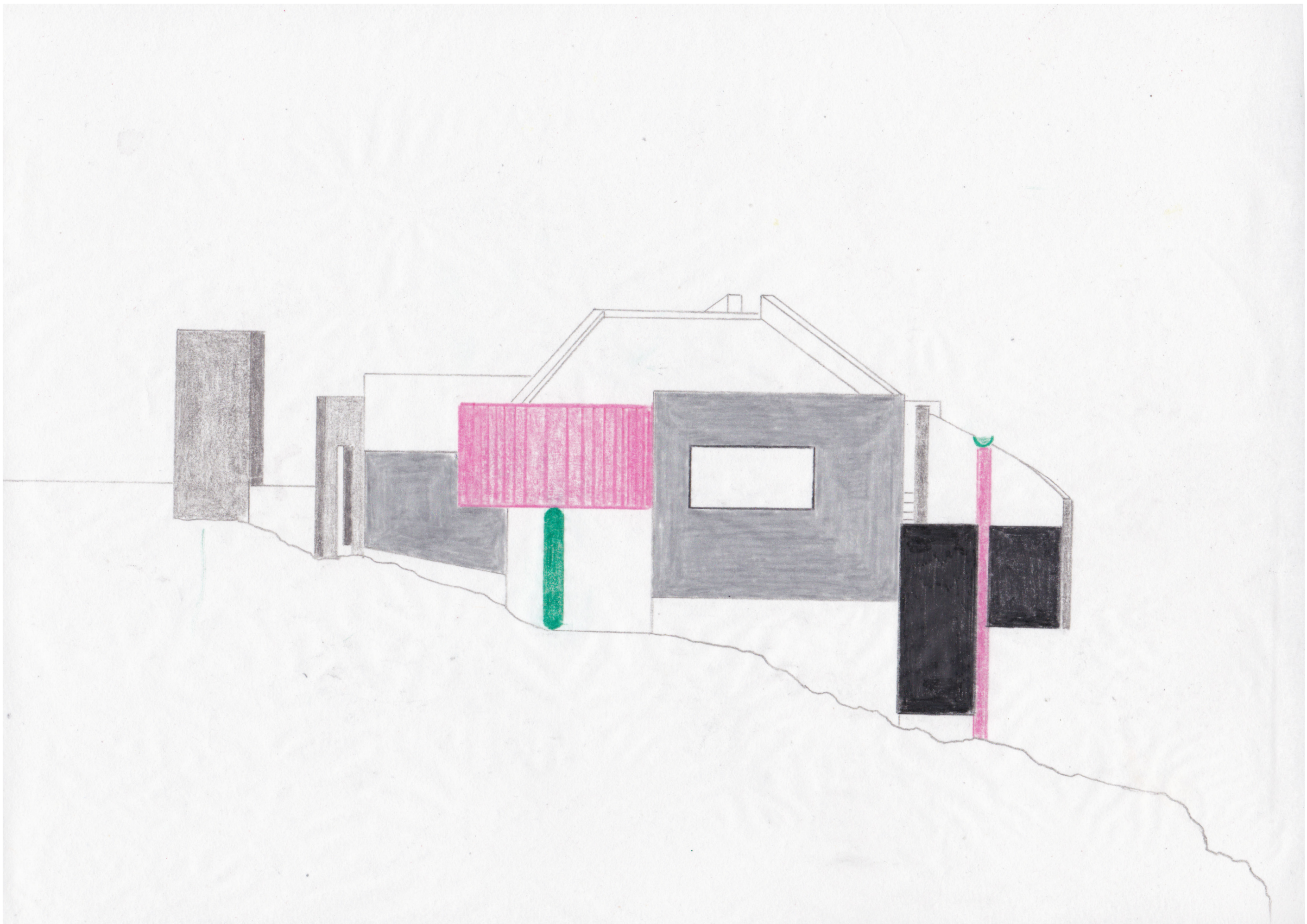



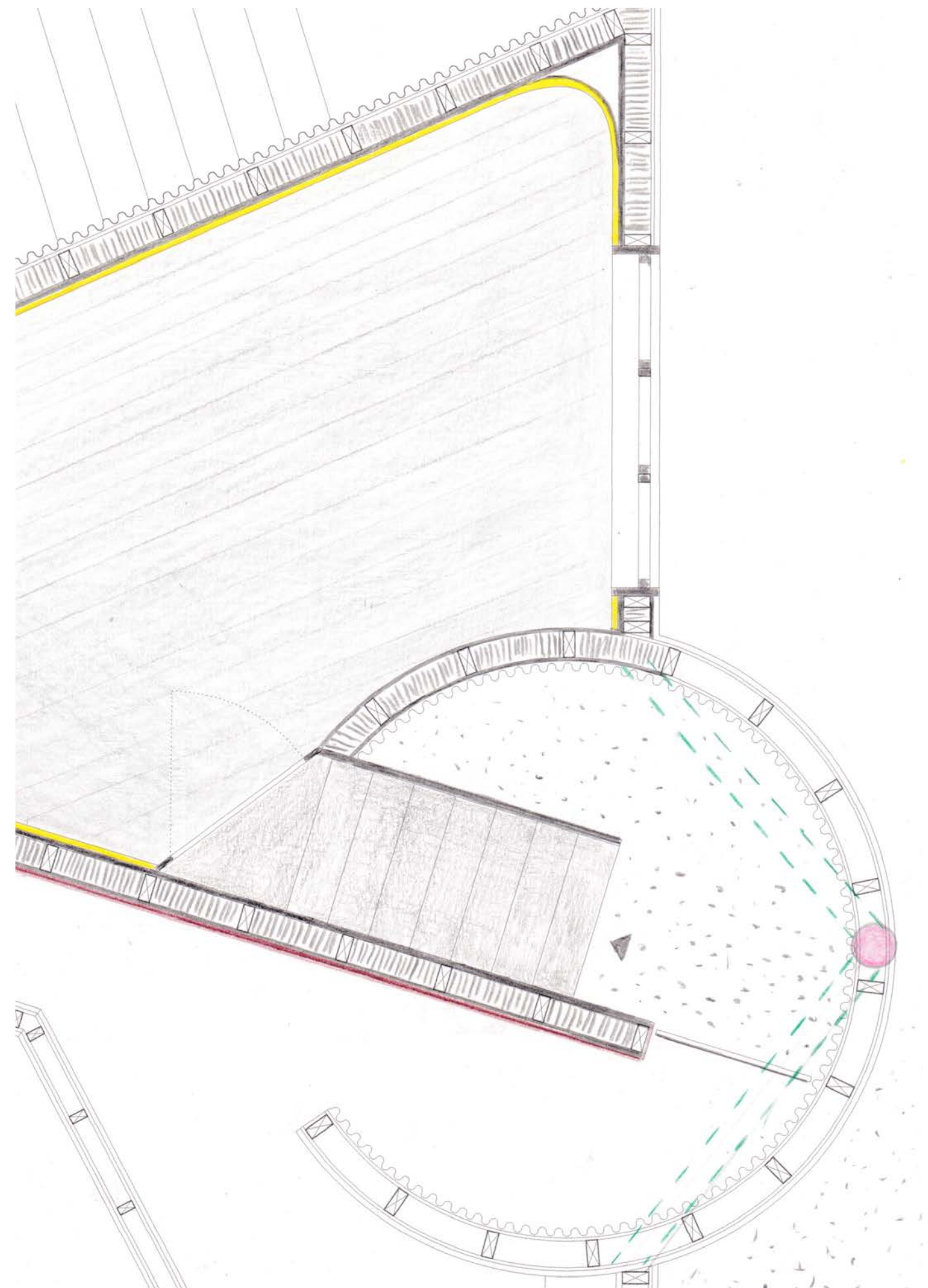
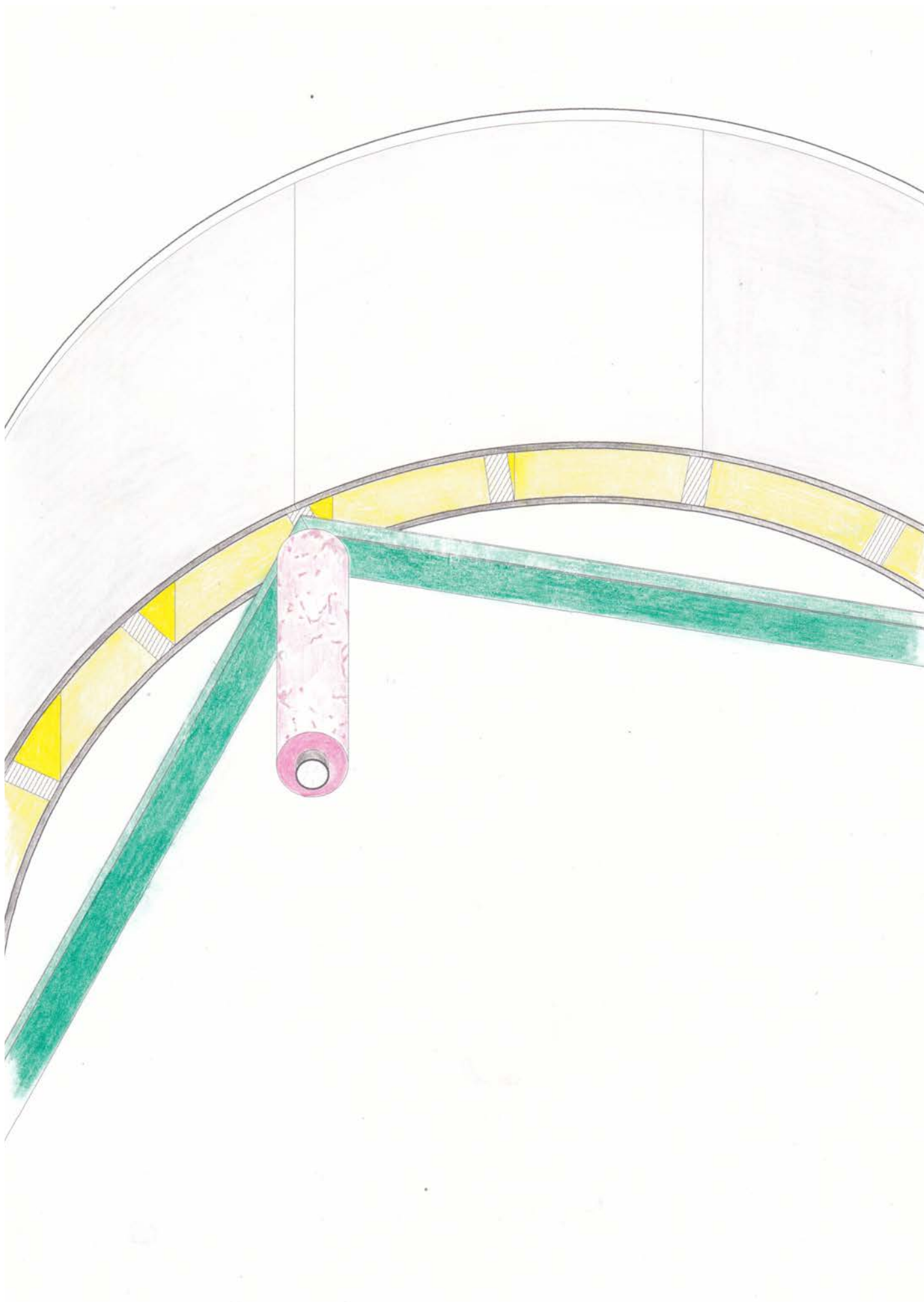

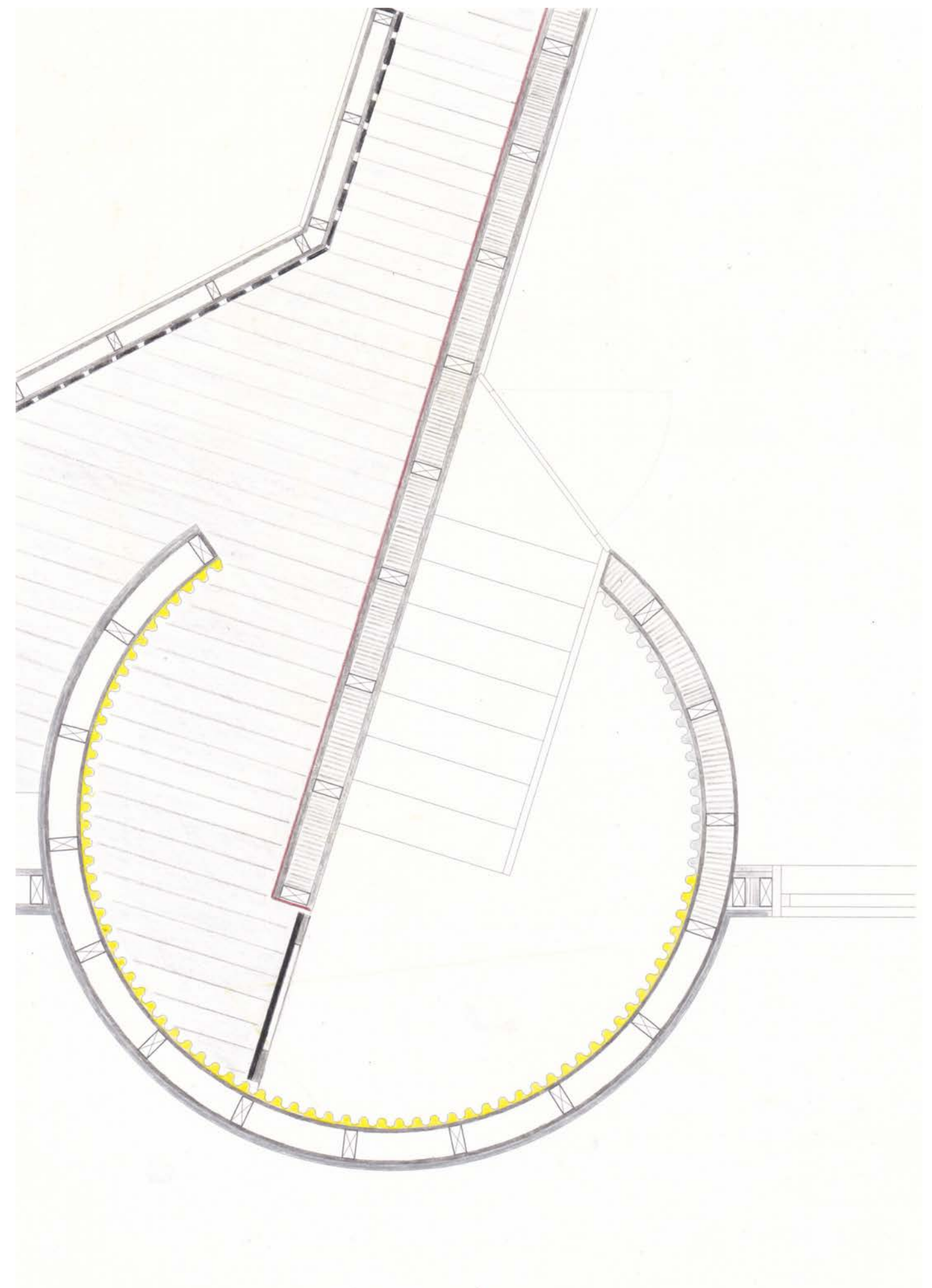
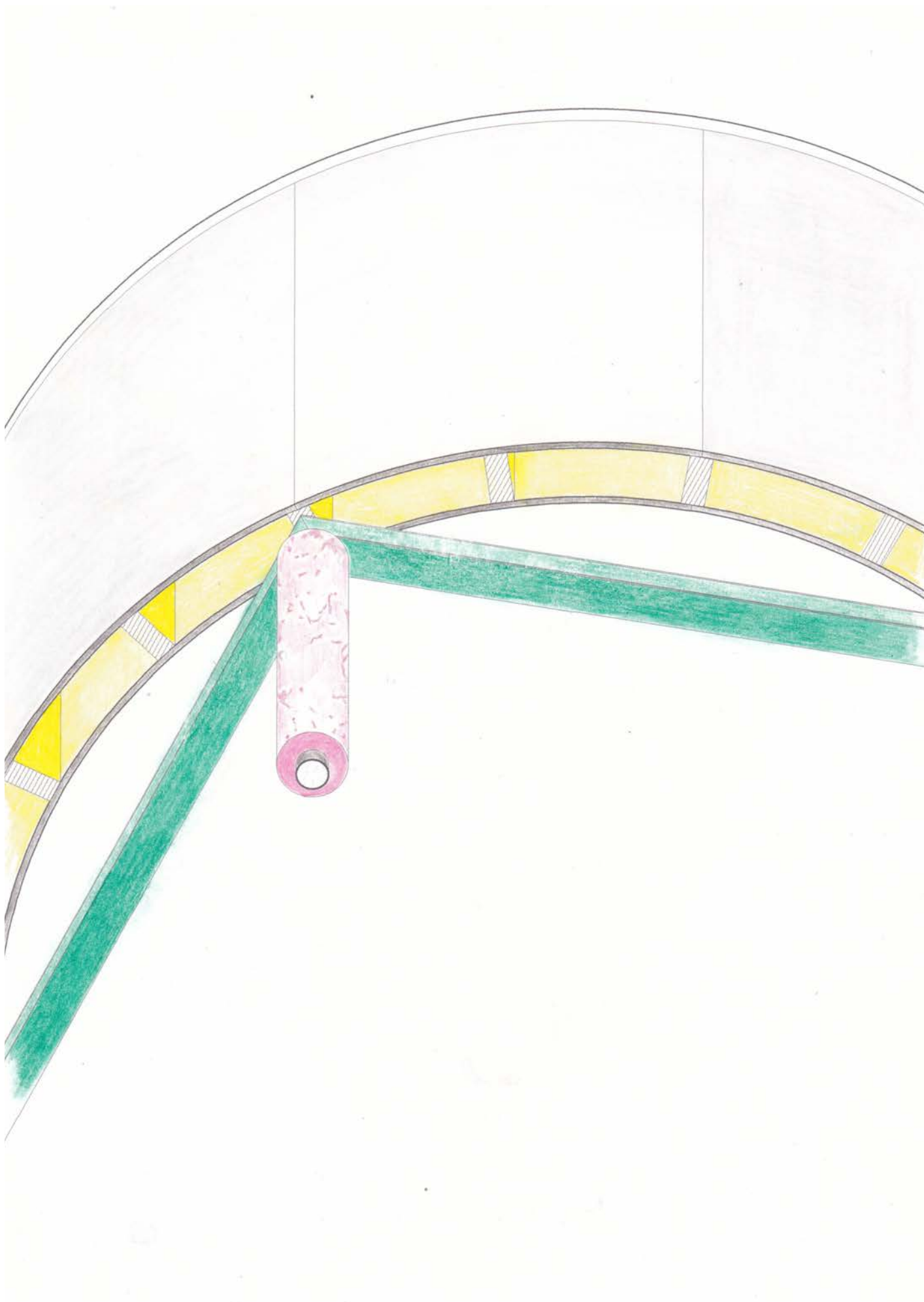



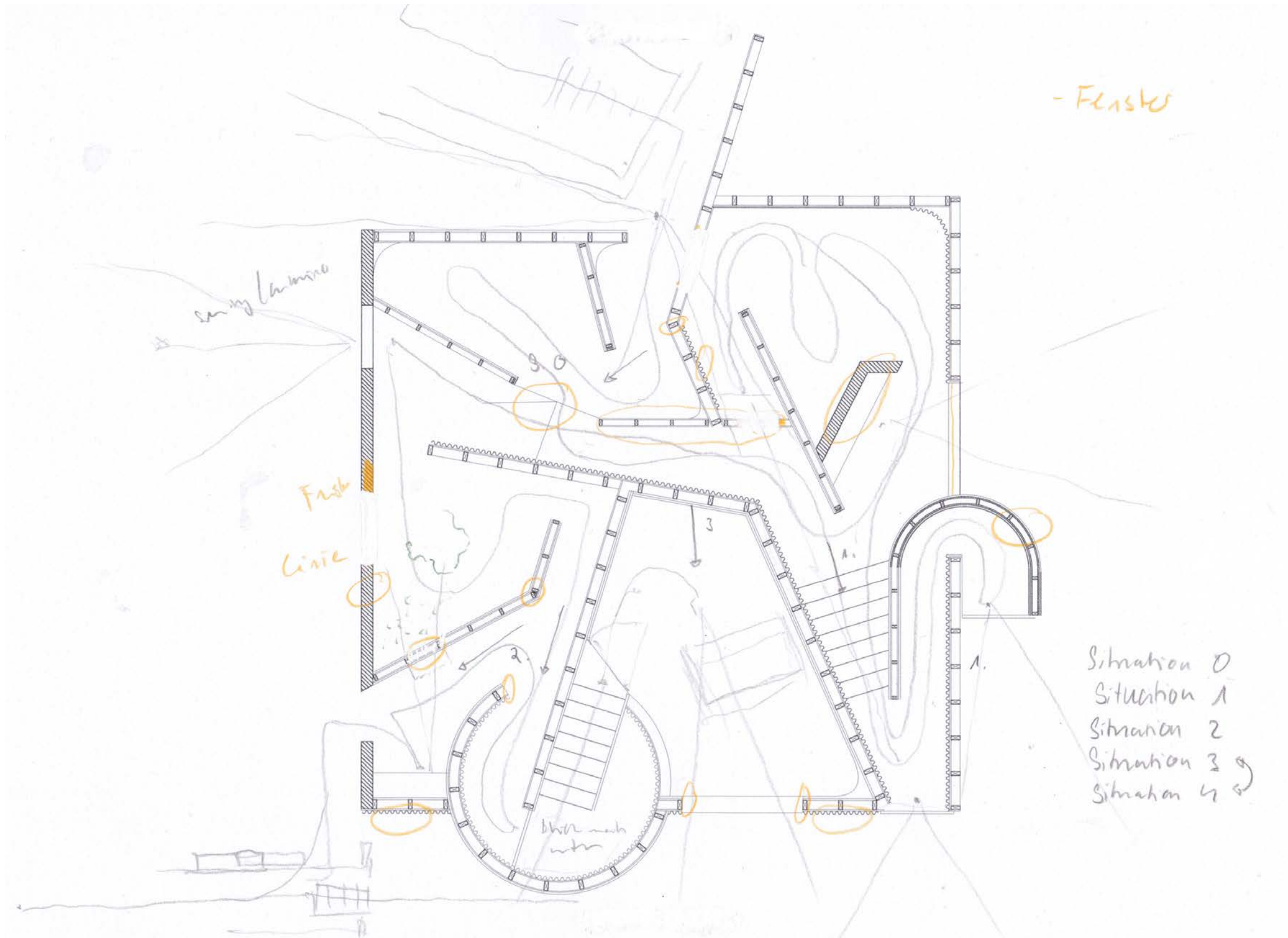





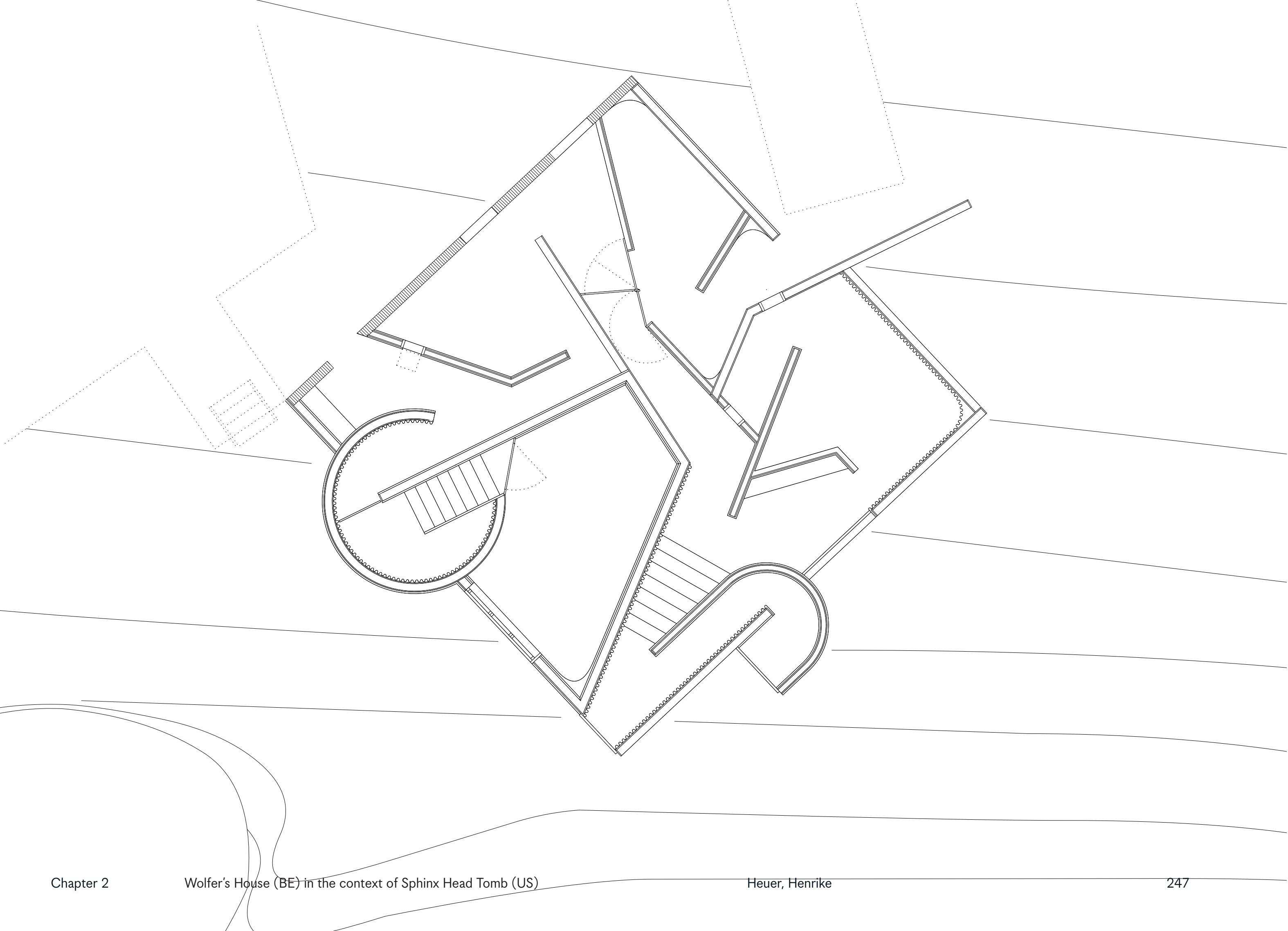

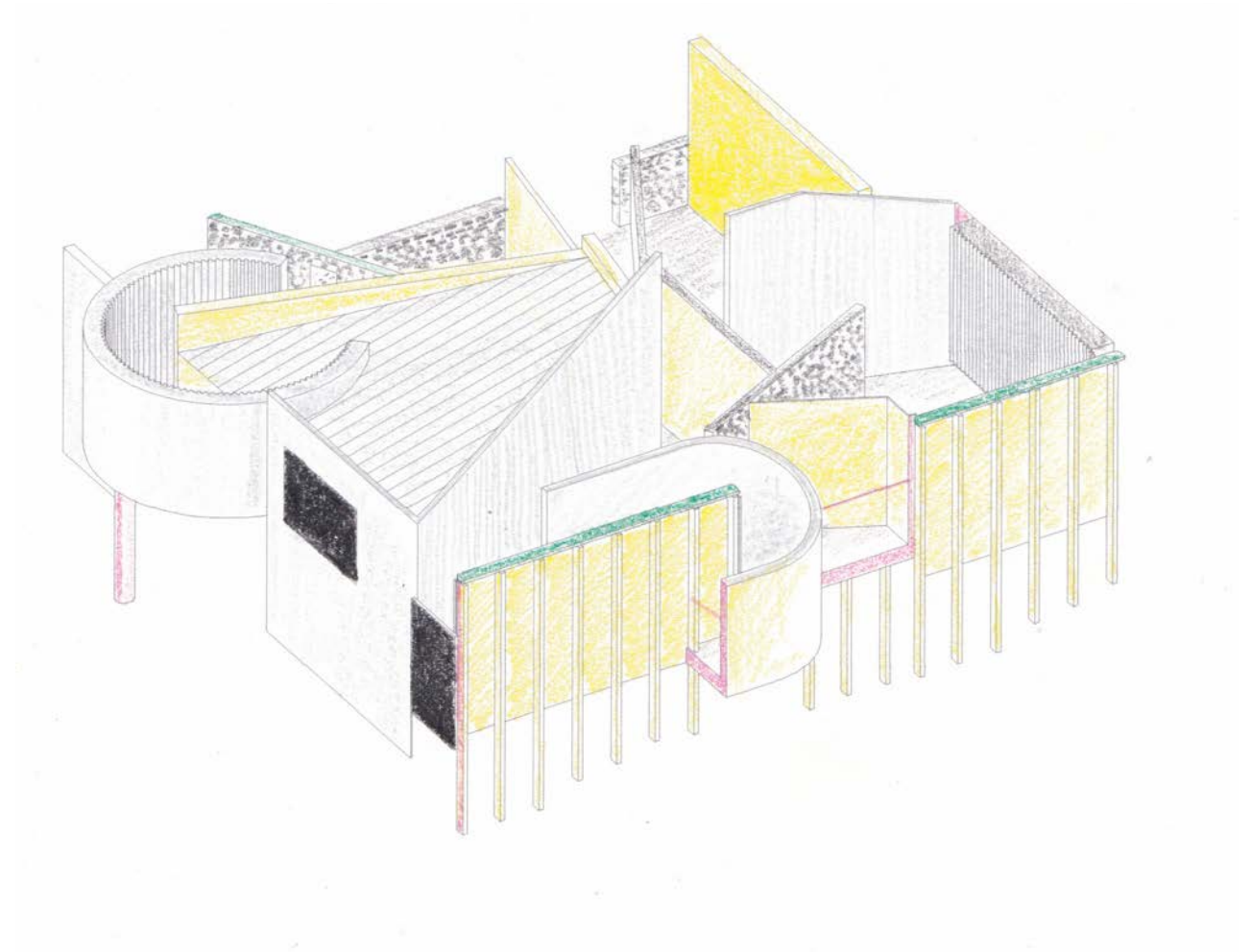



## Movement 2

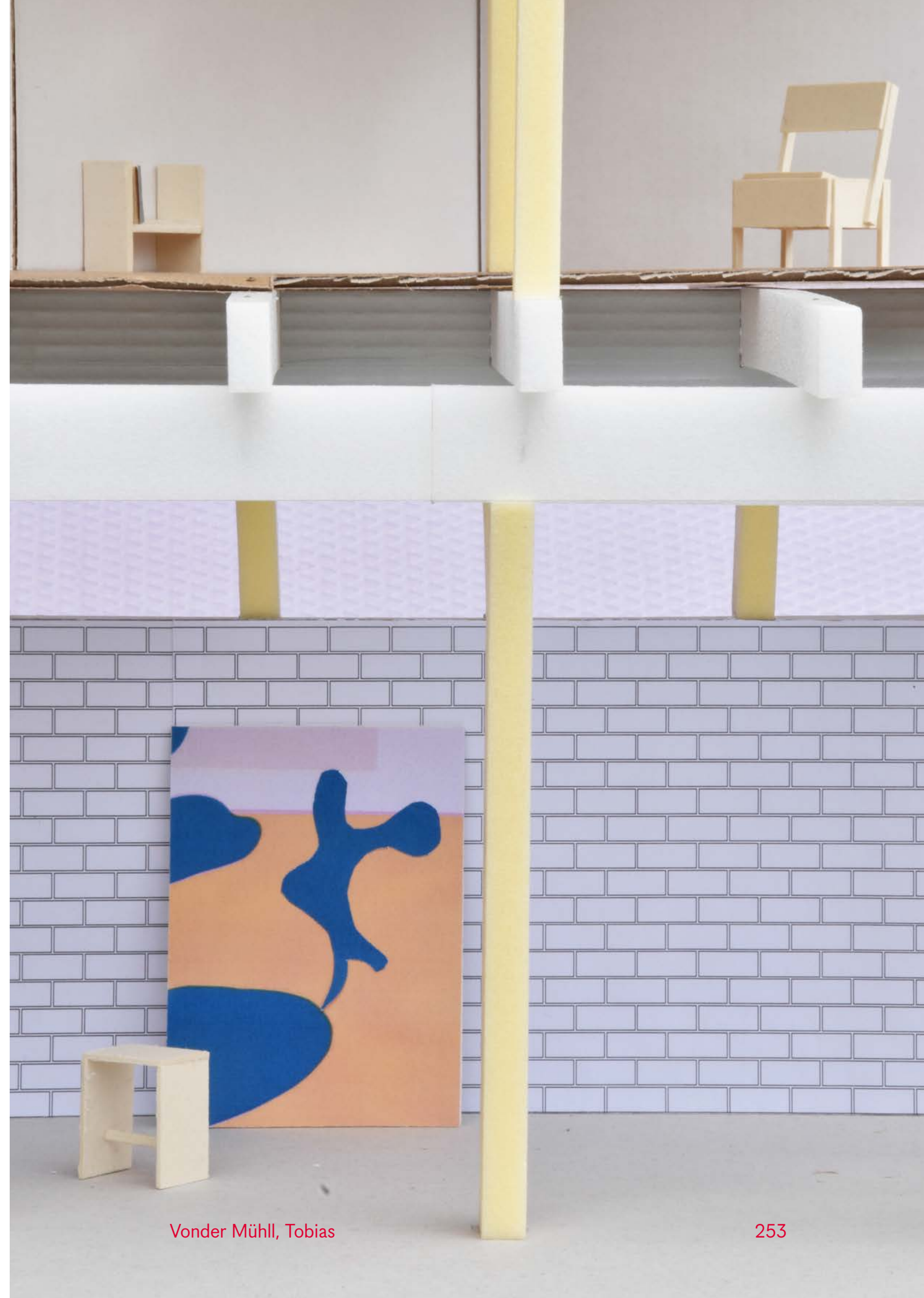







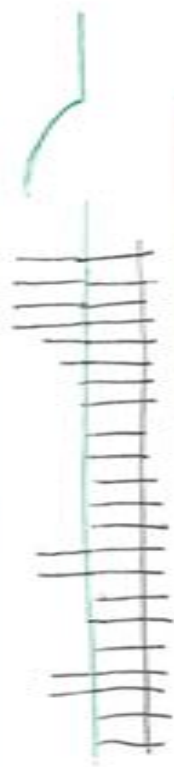

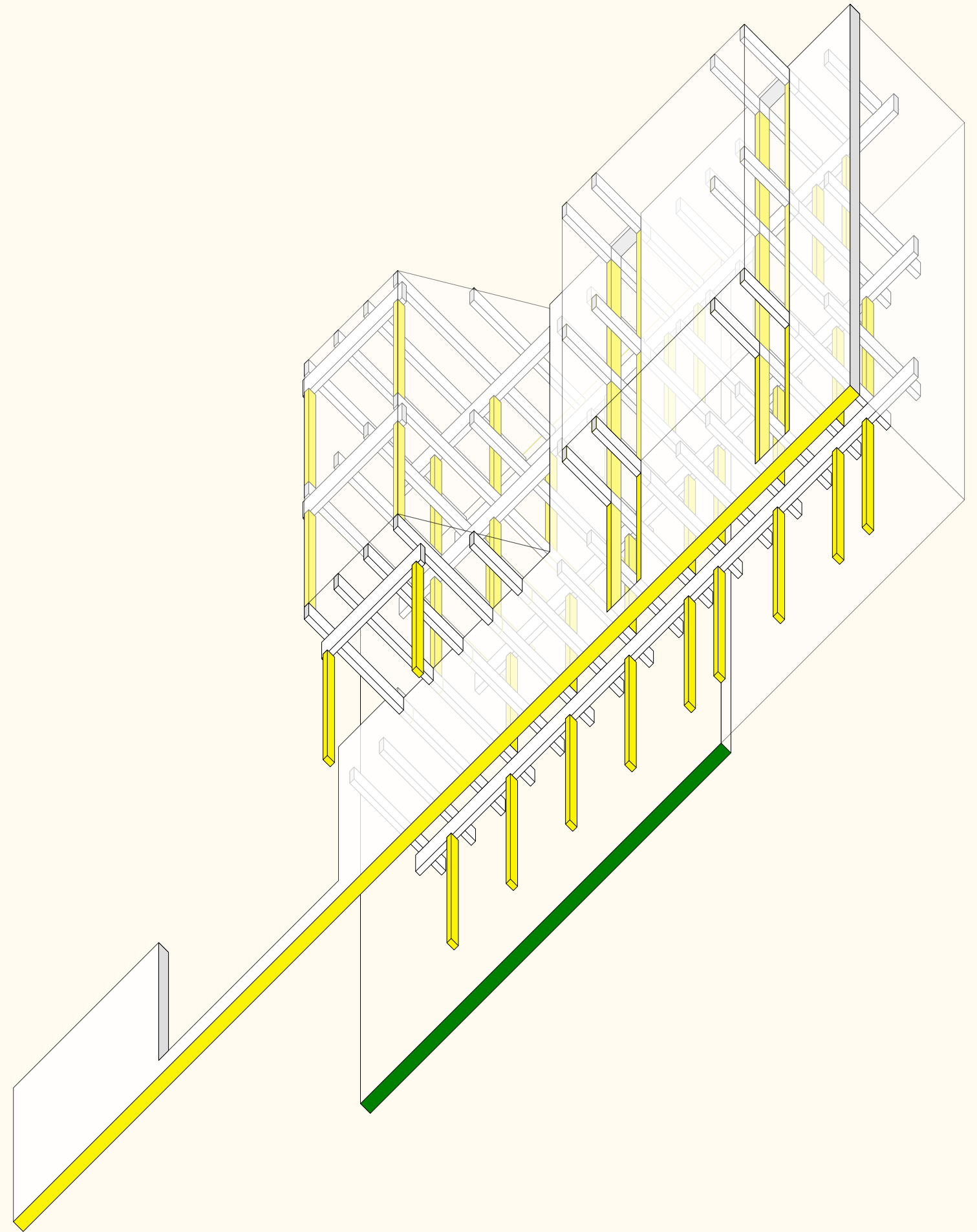
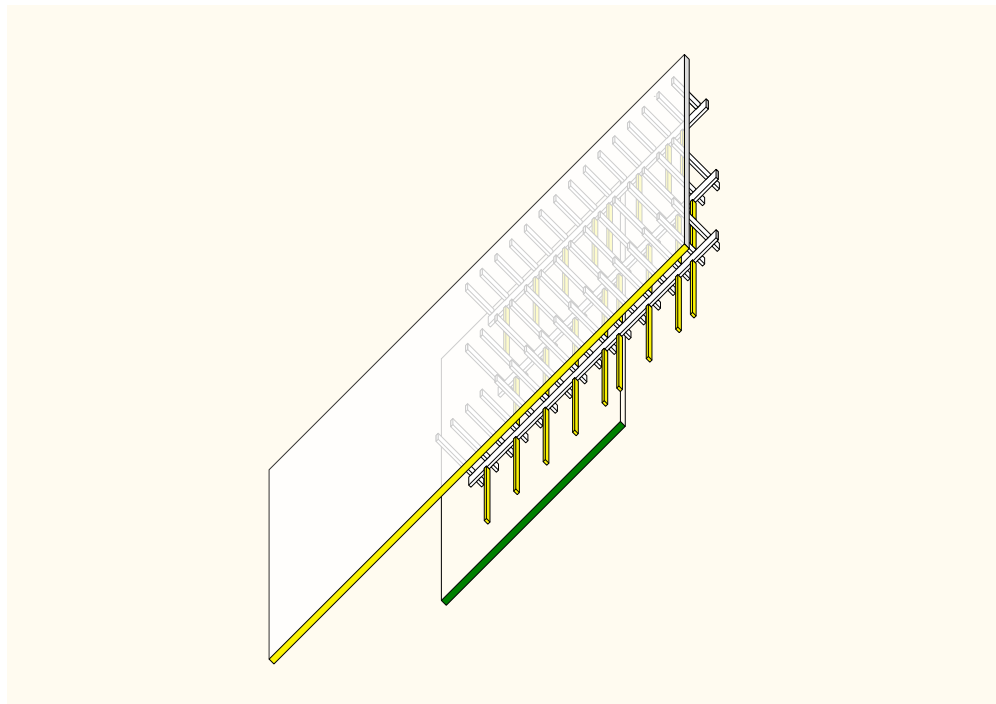

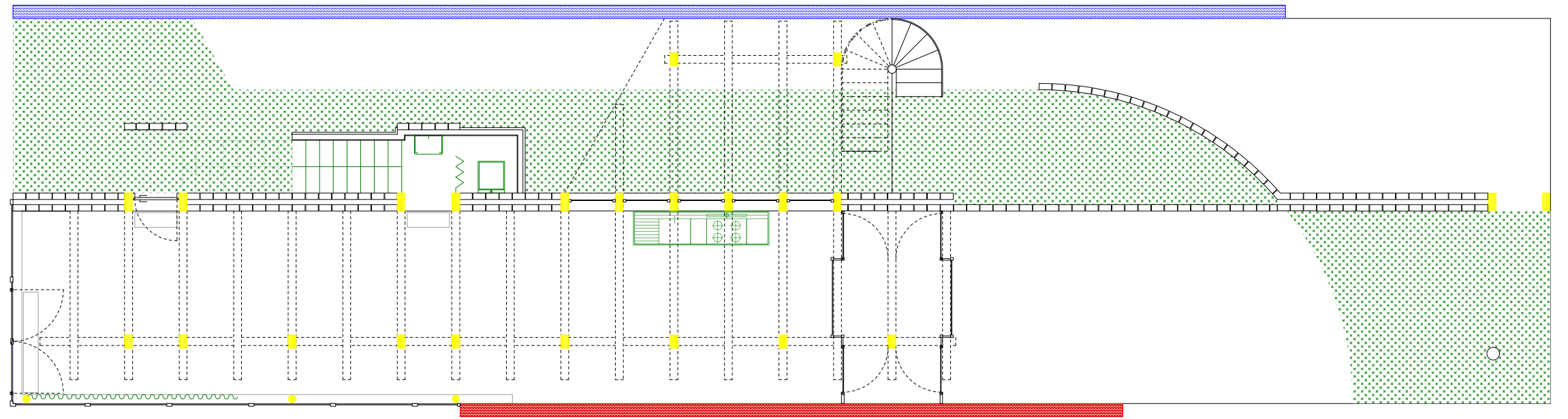

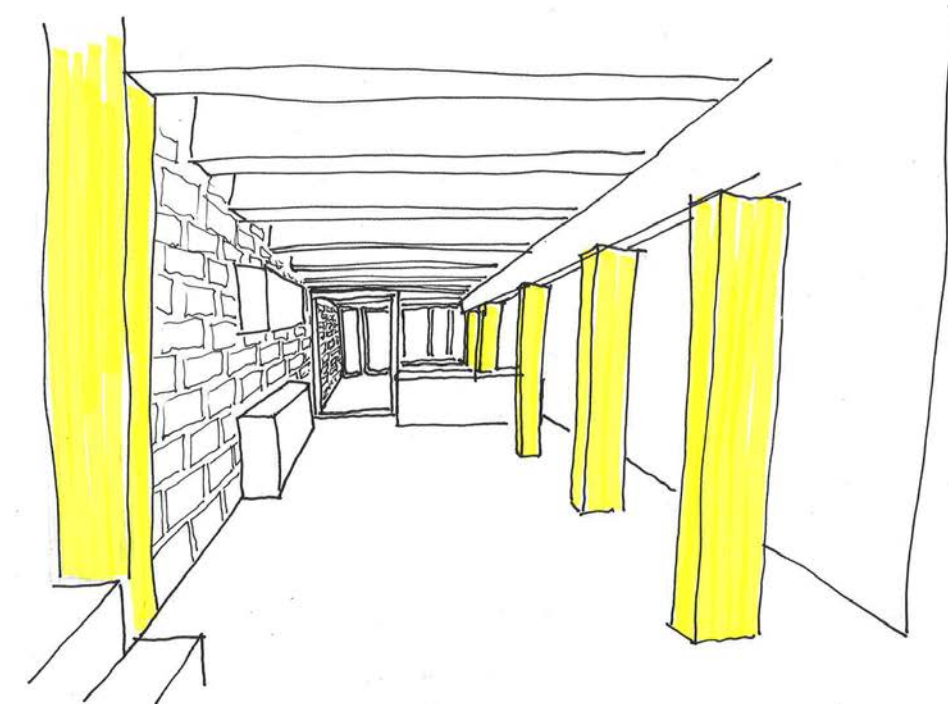
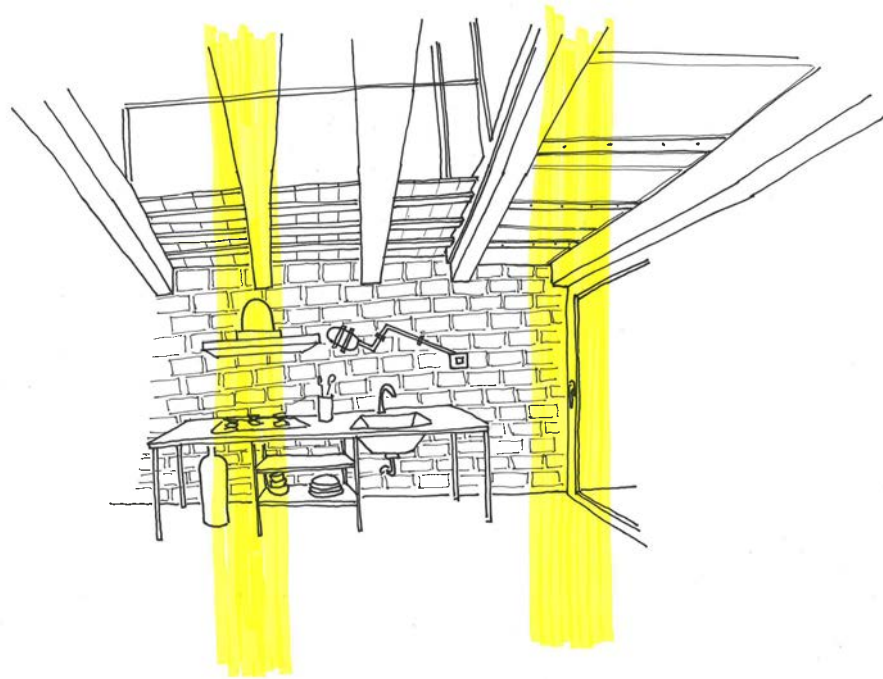



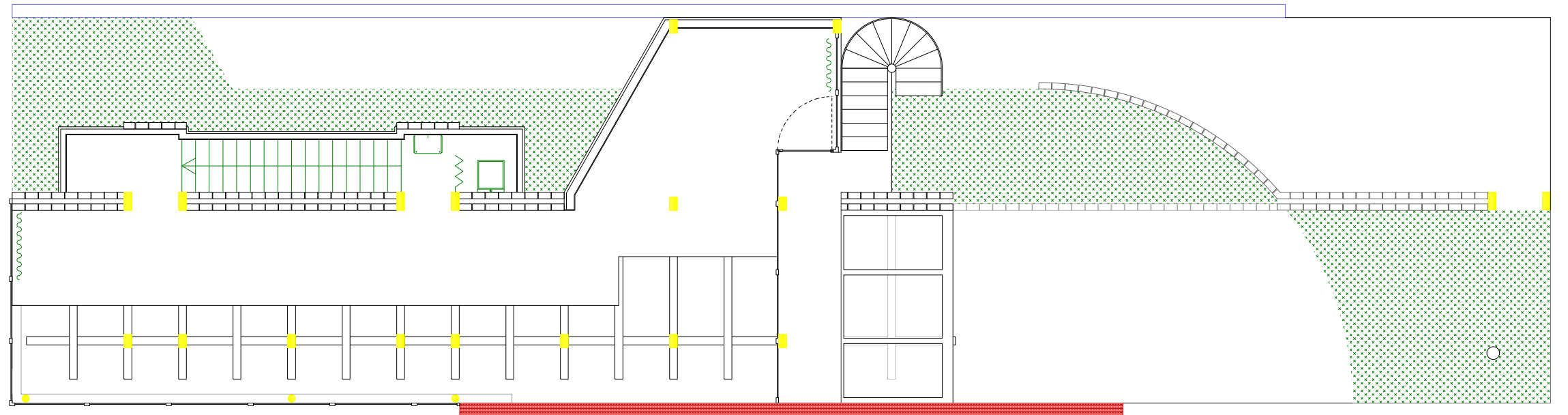

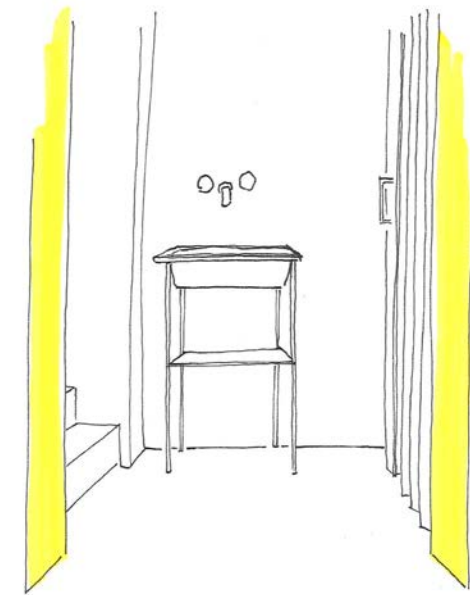
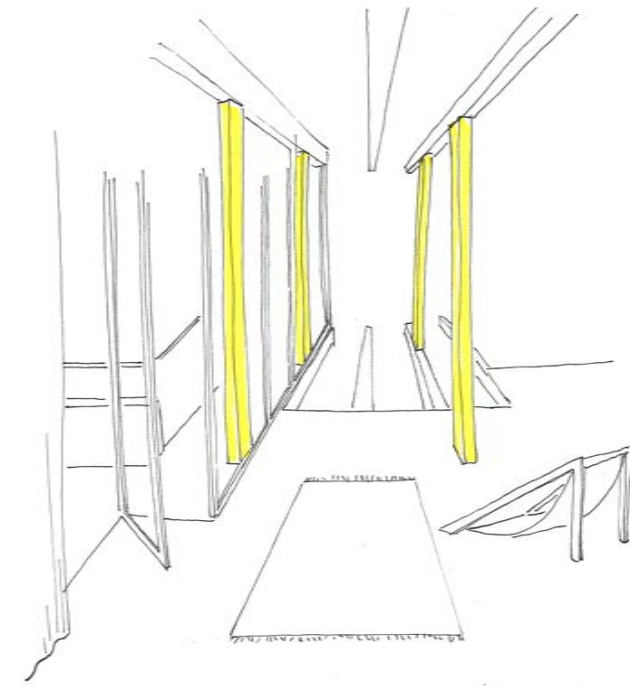



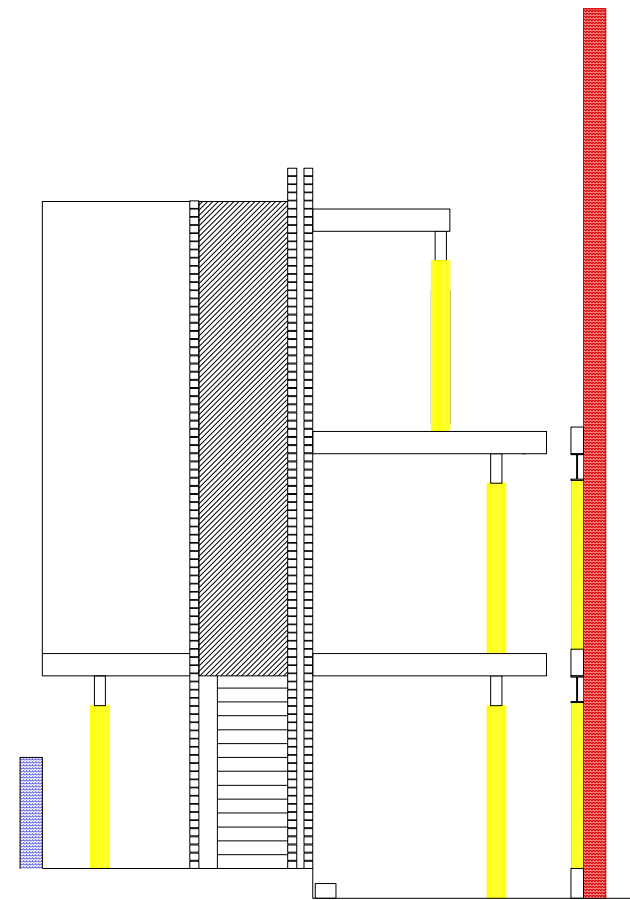
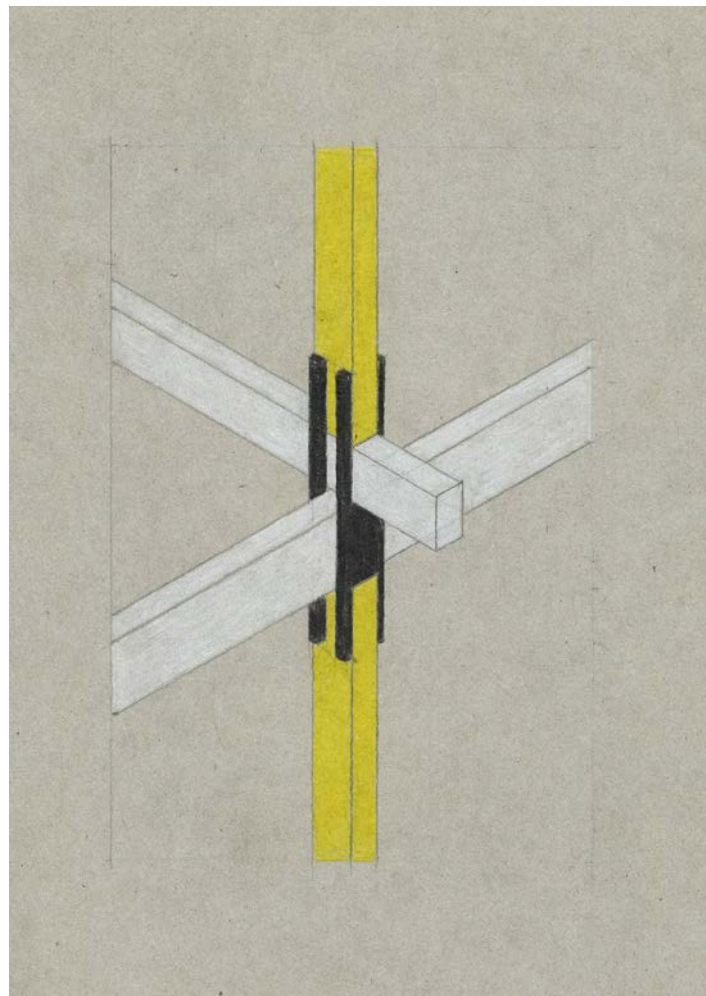
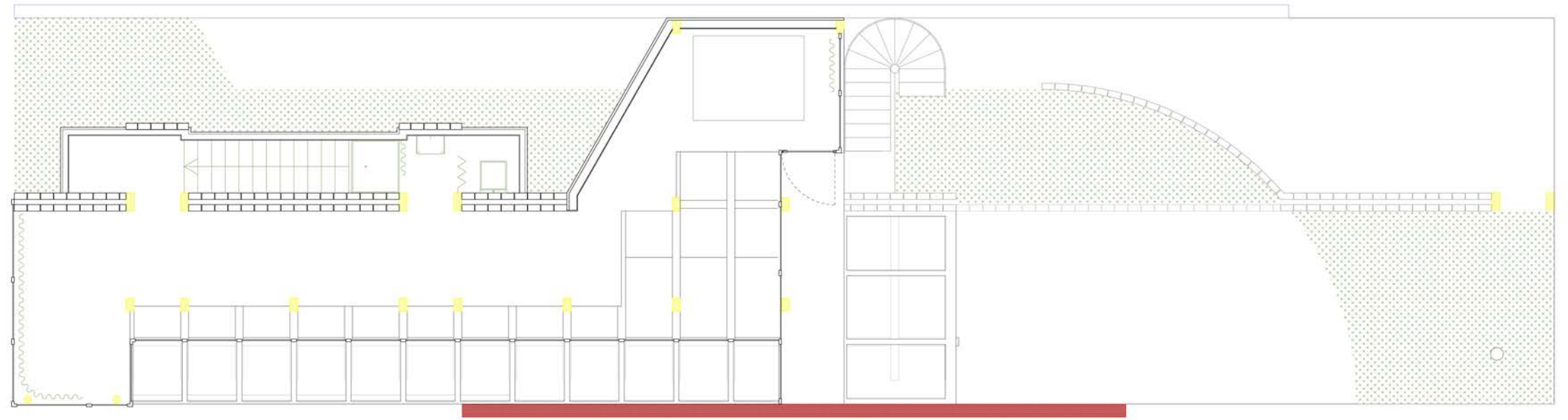

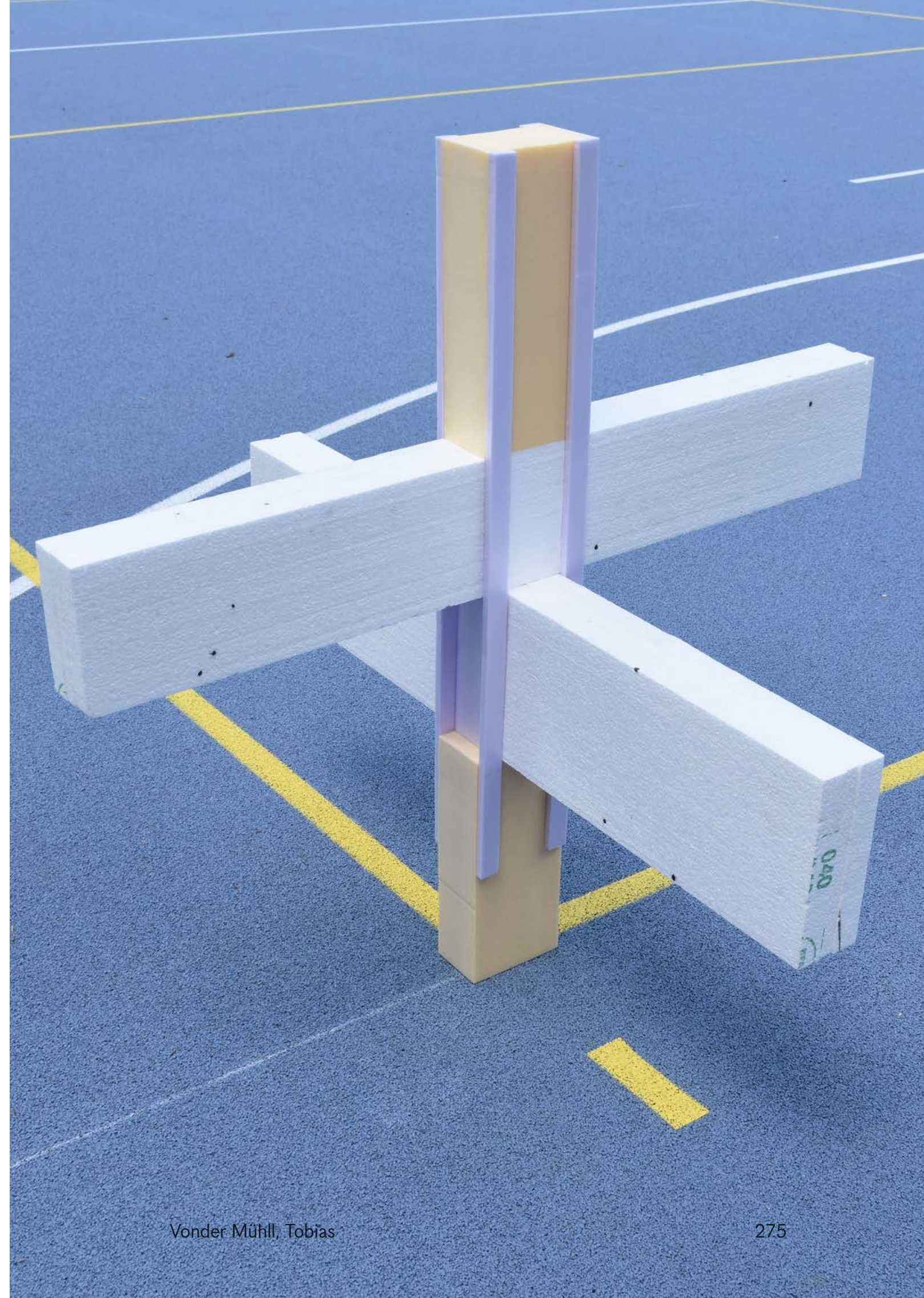
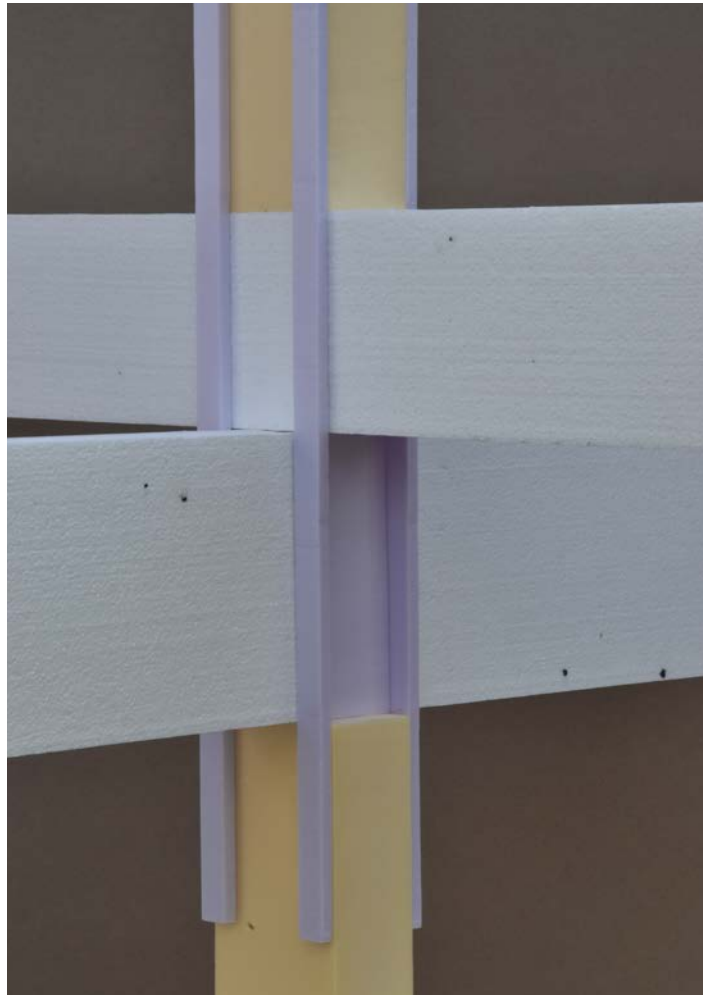

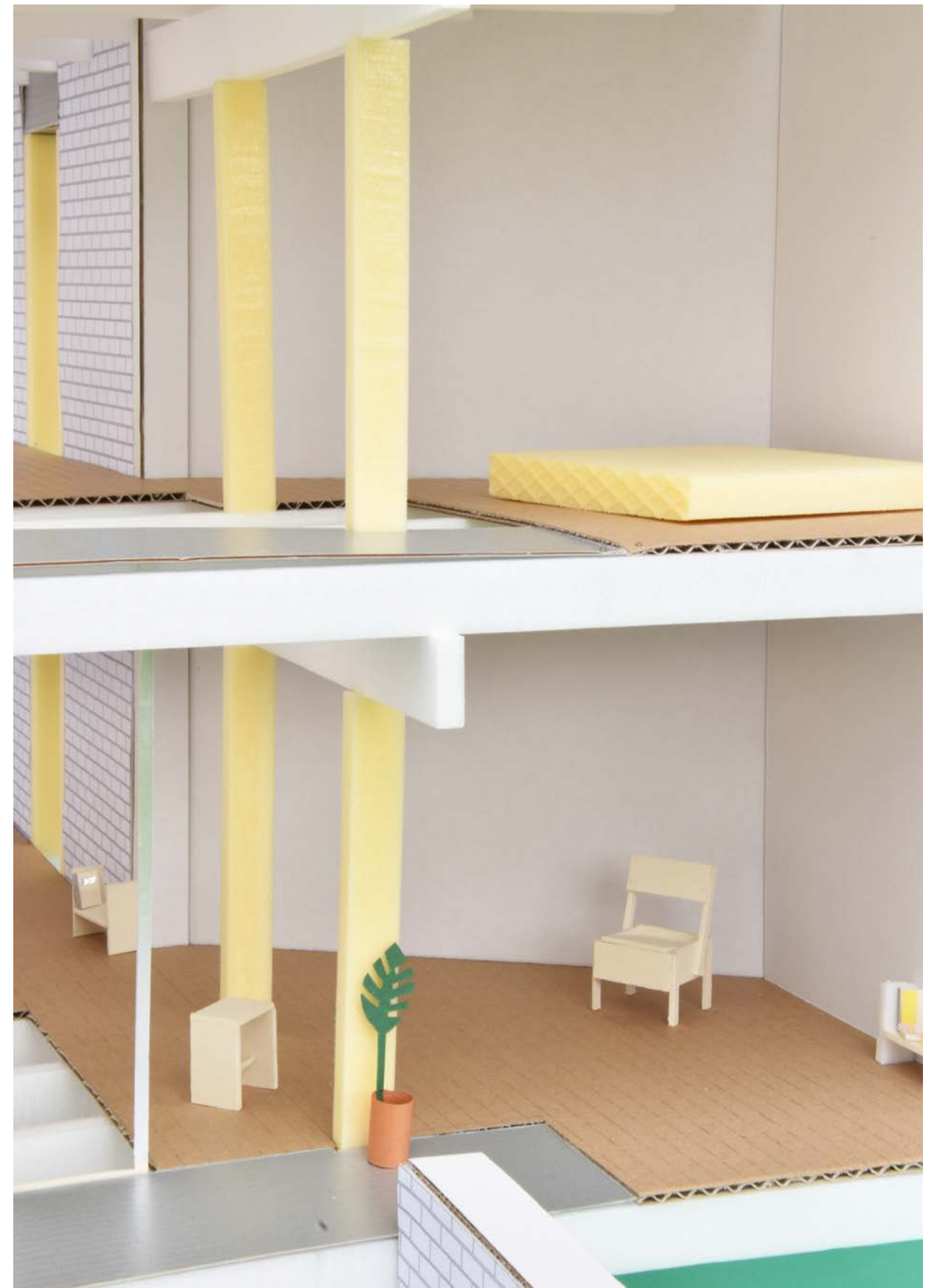
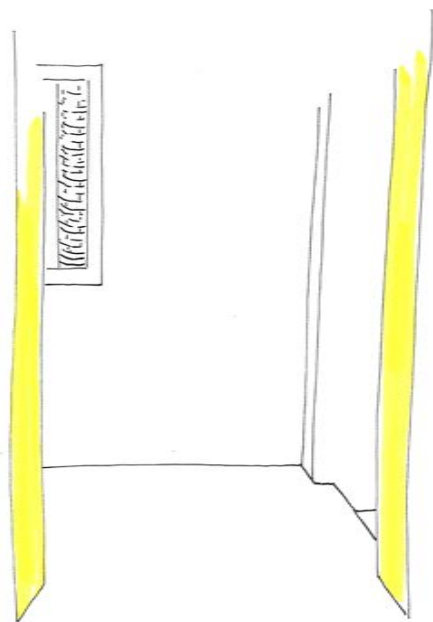
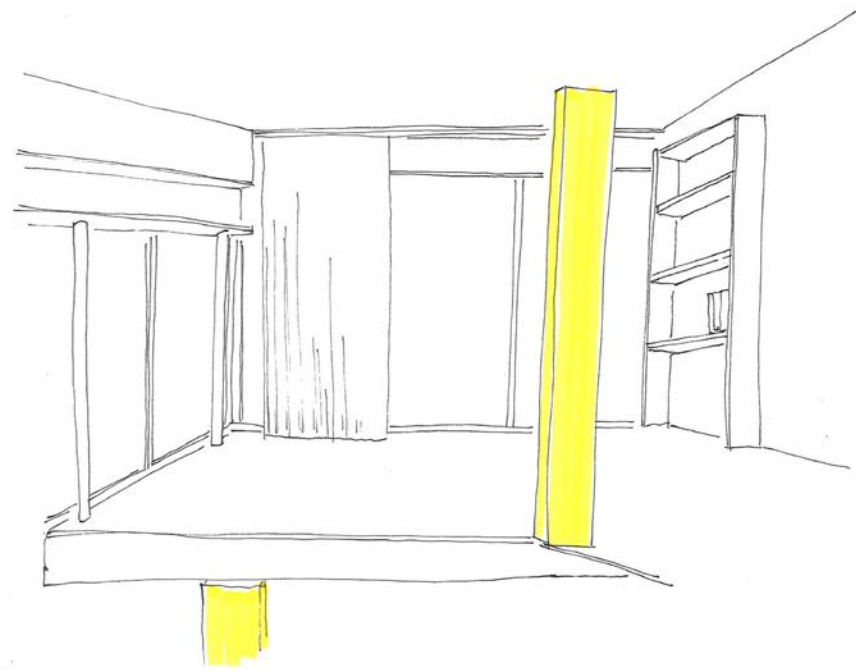

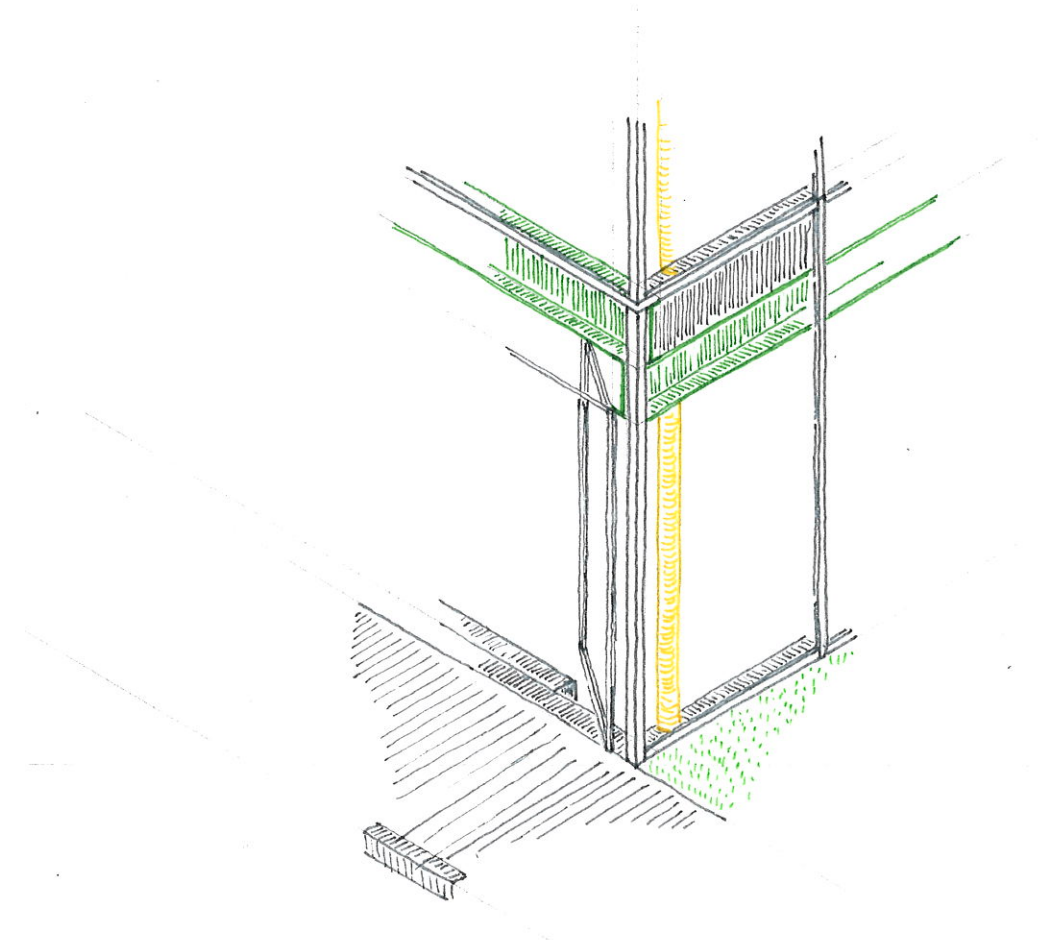

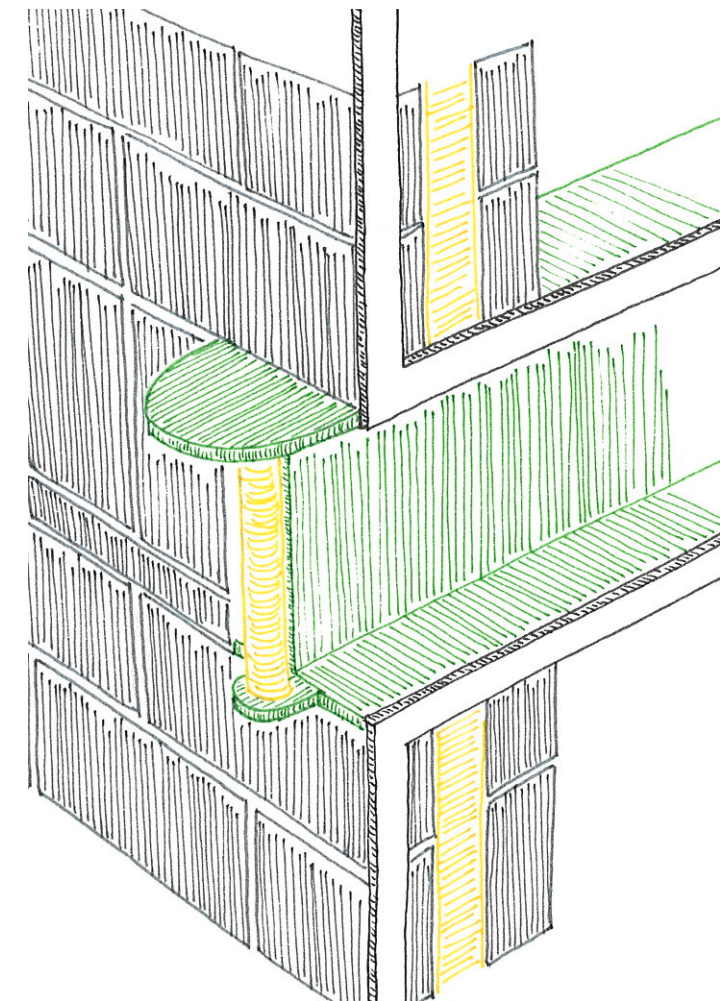
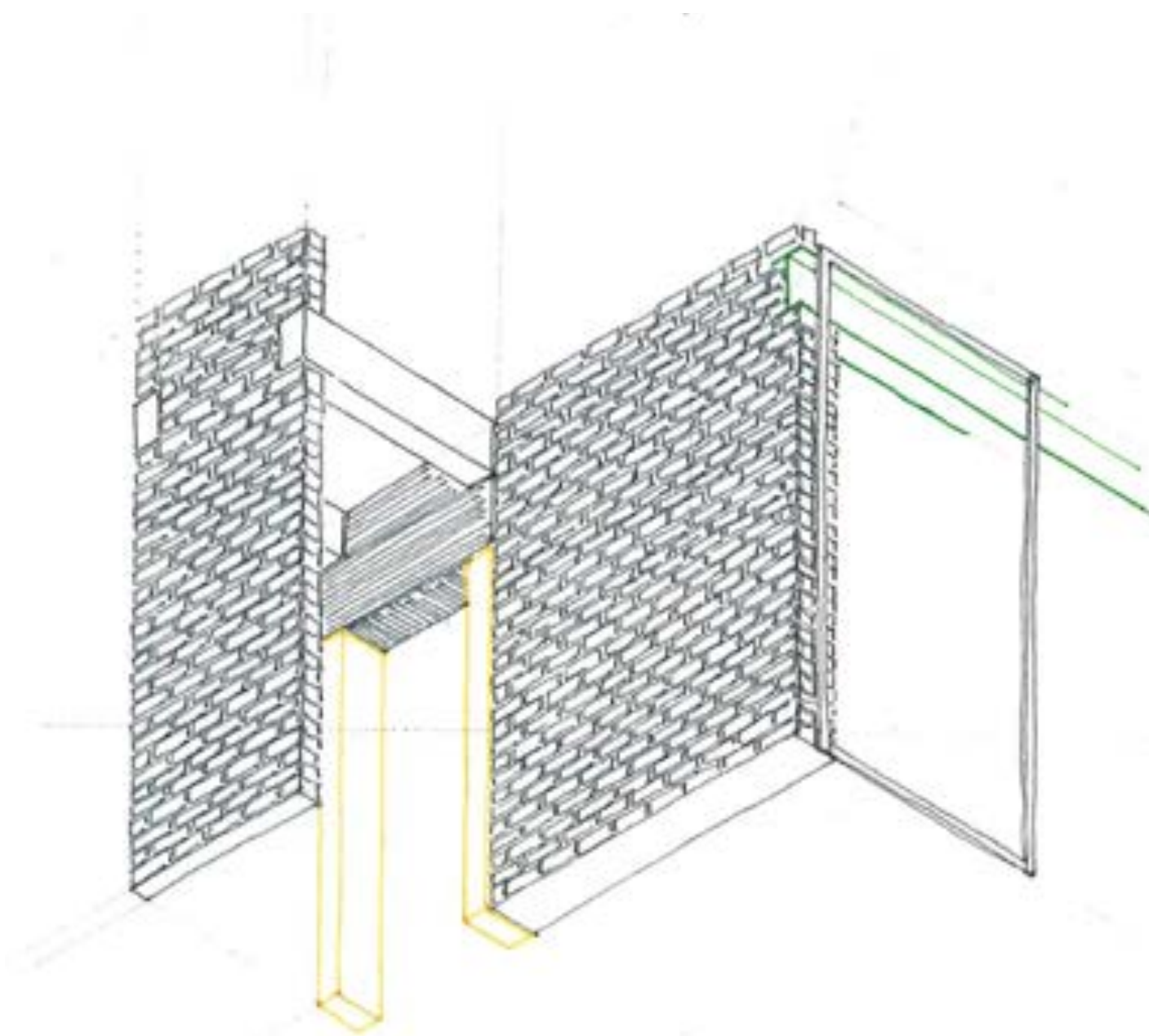

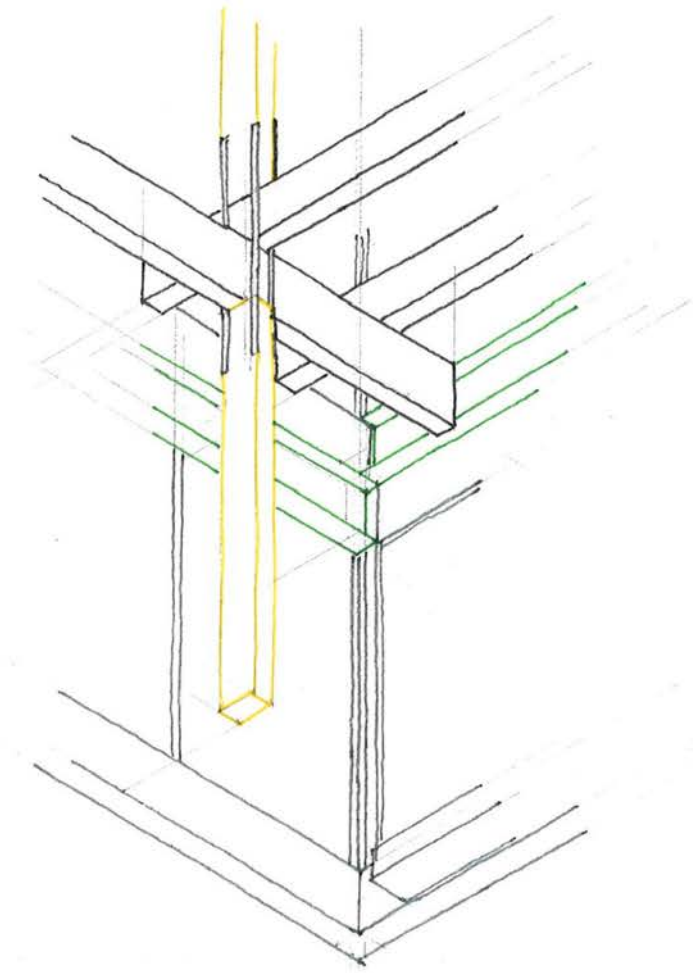

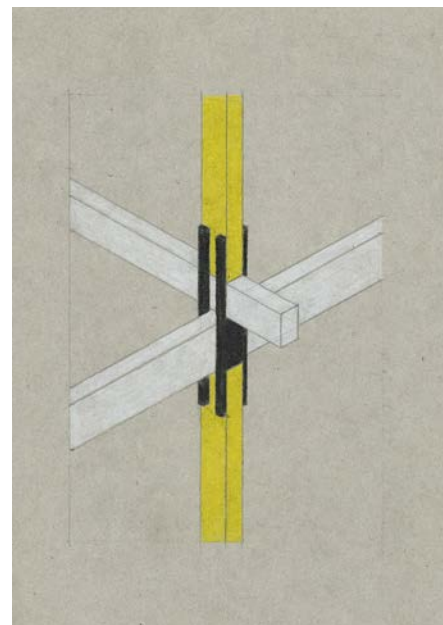
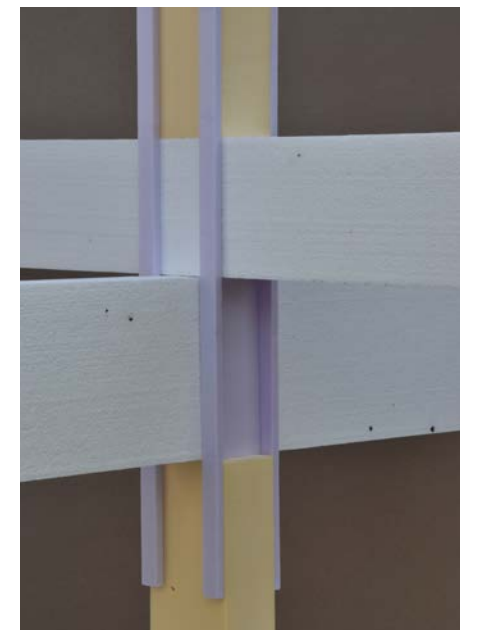
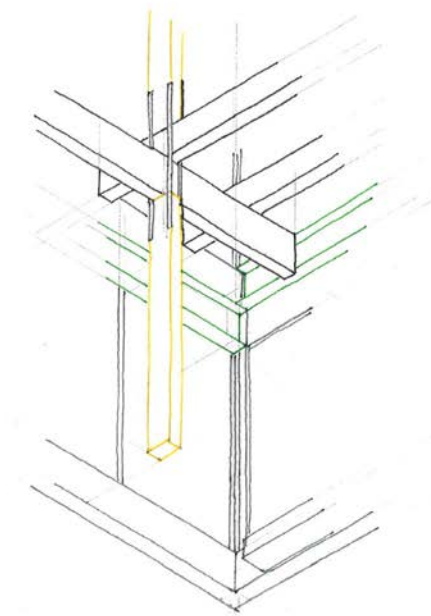
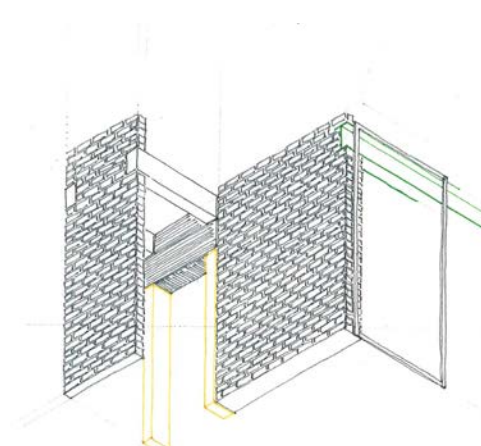
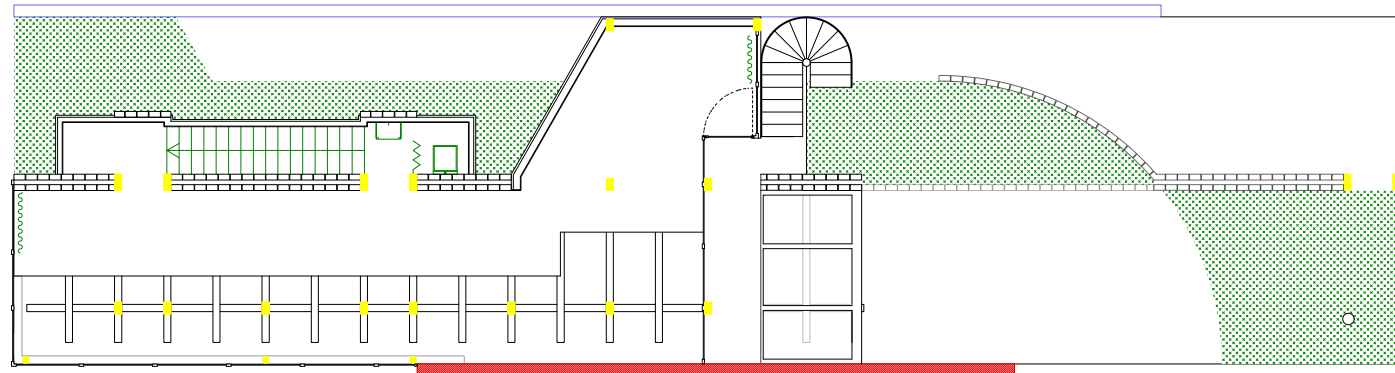
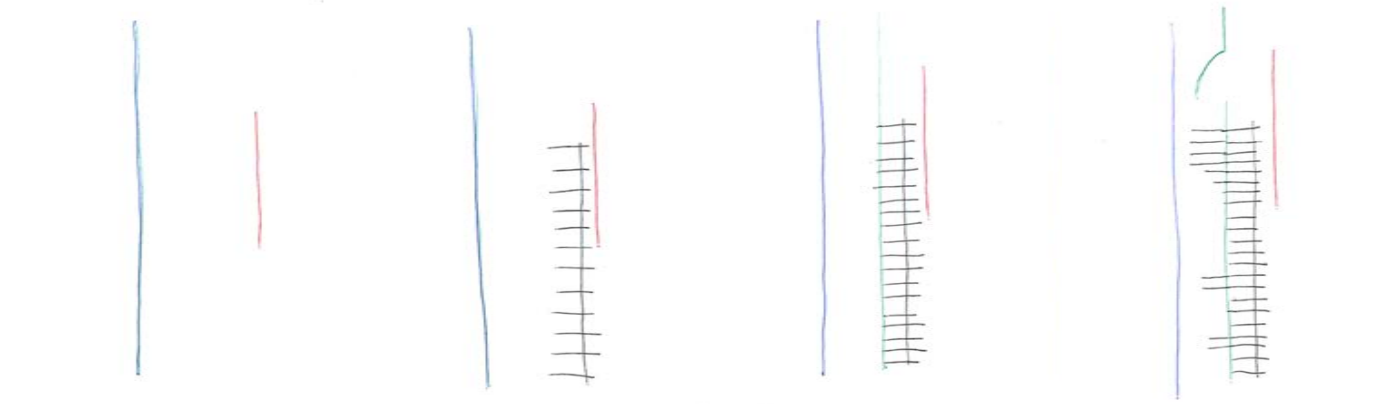

# Movement 2





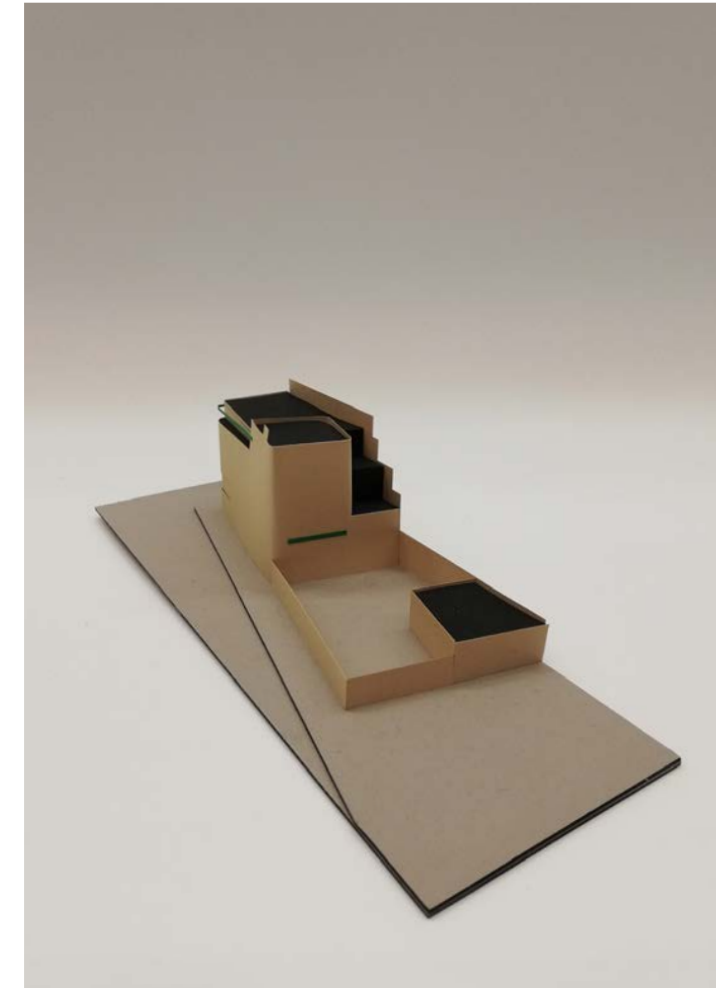

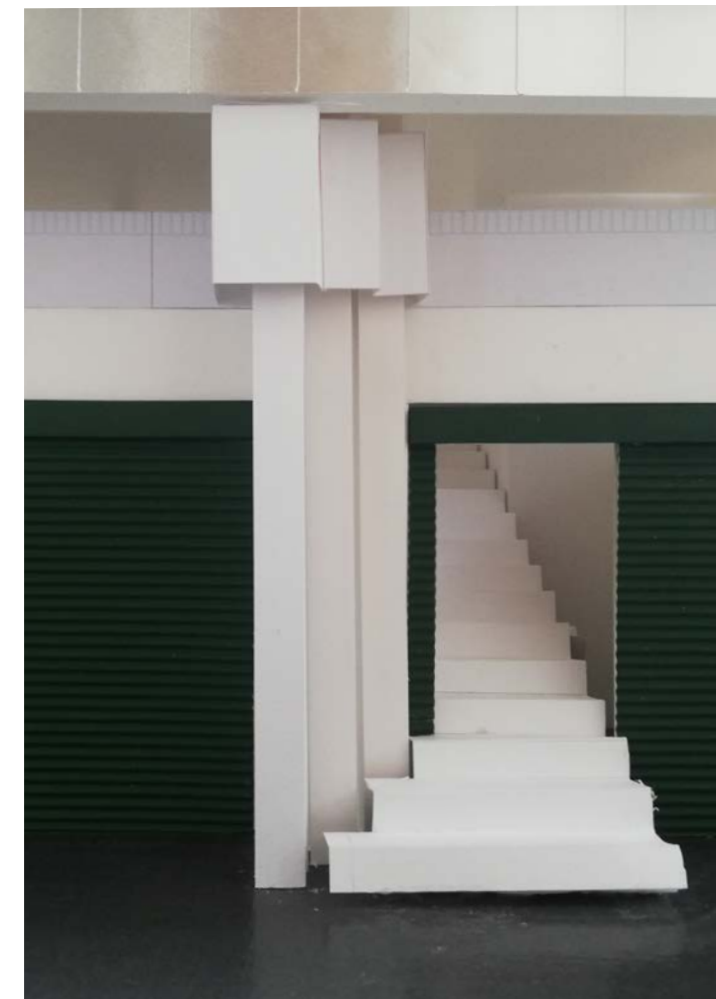

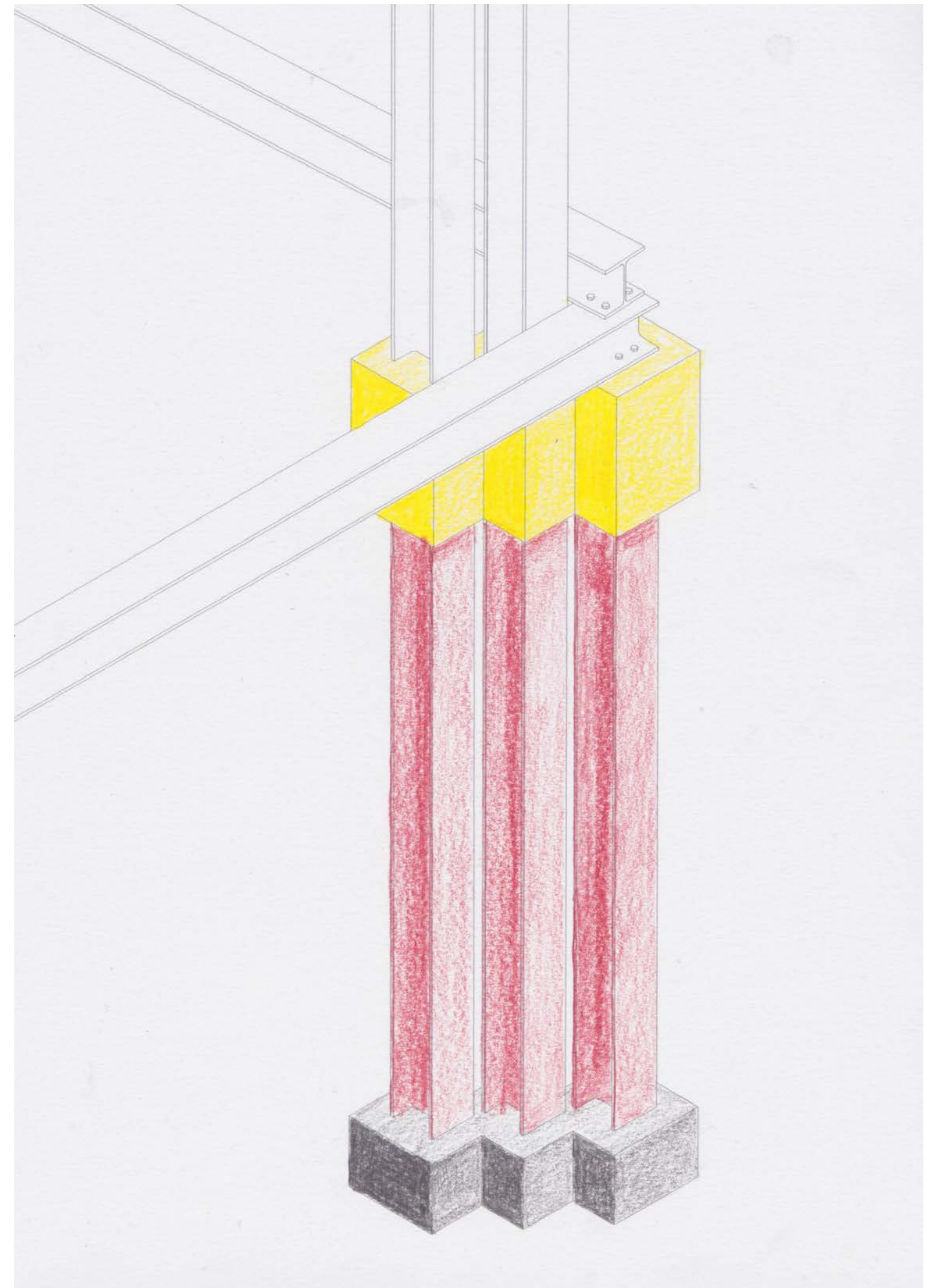
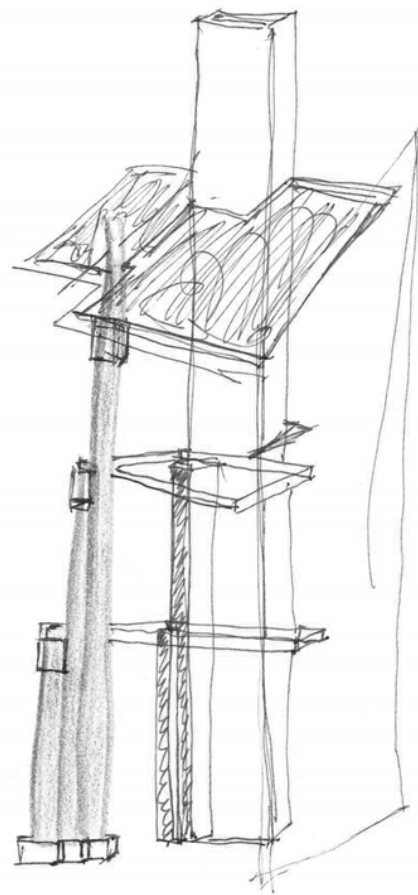
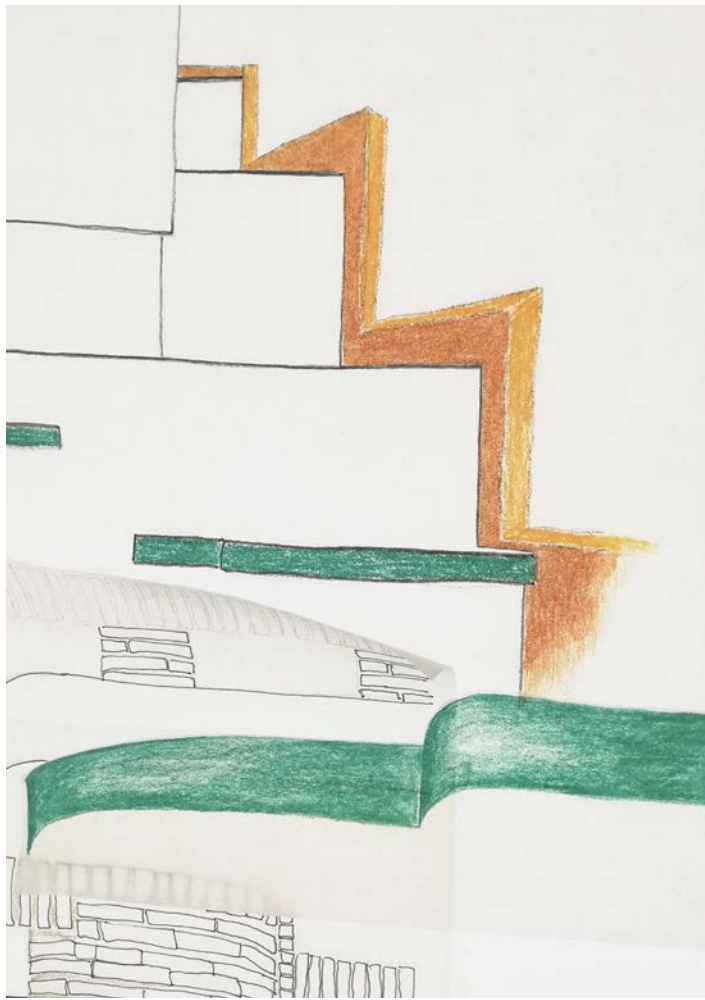

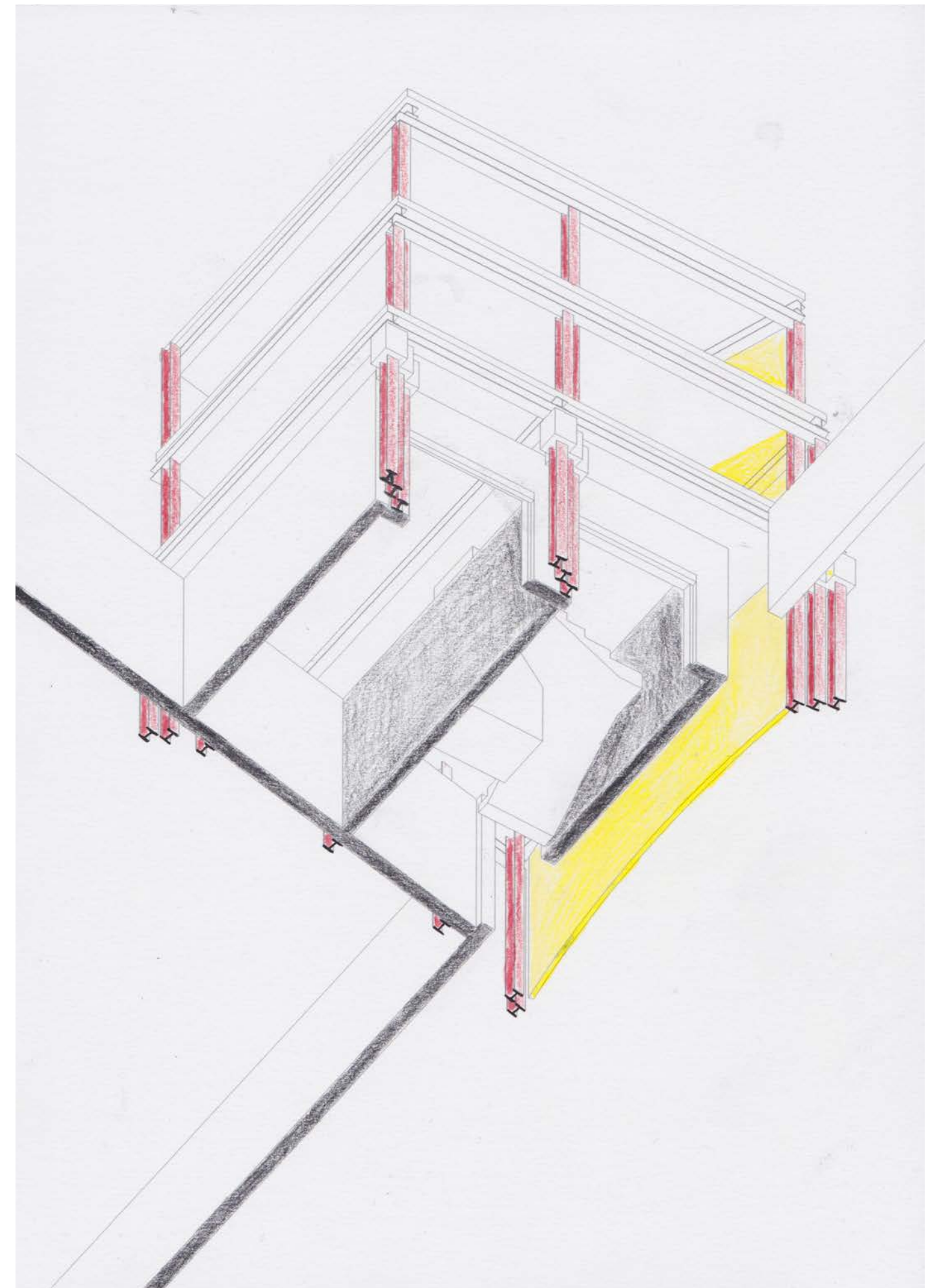
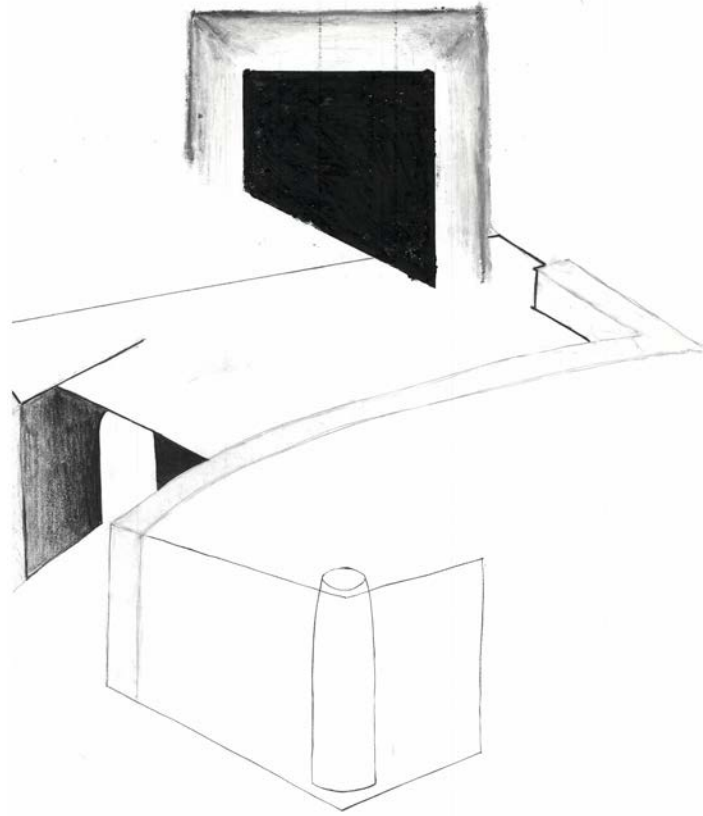

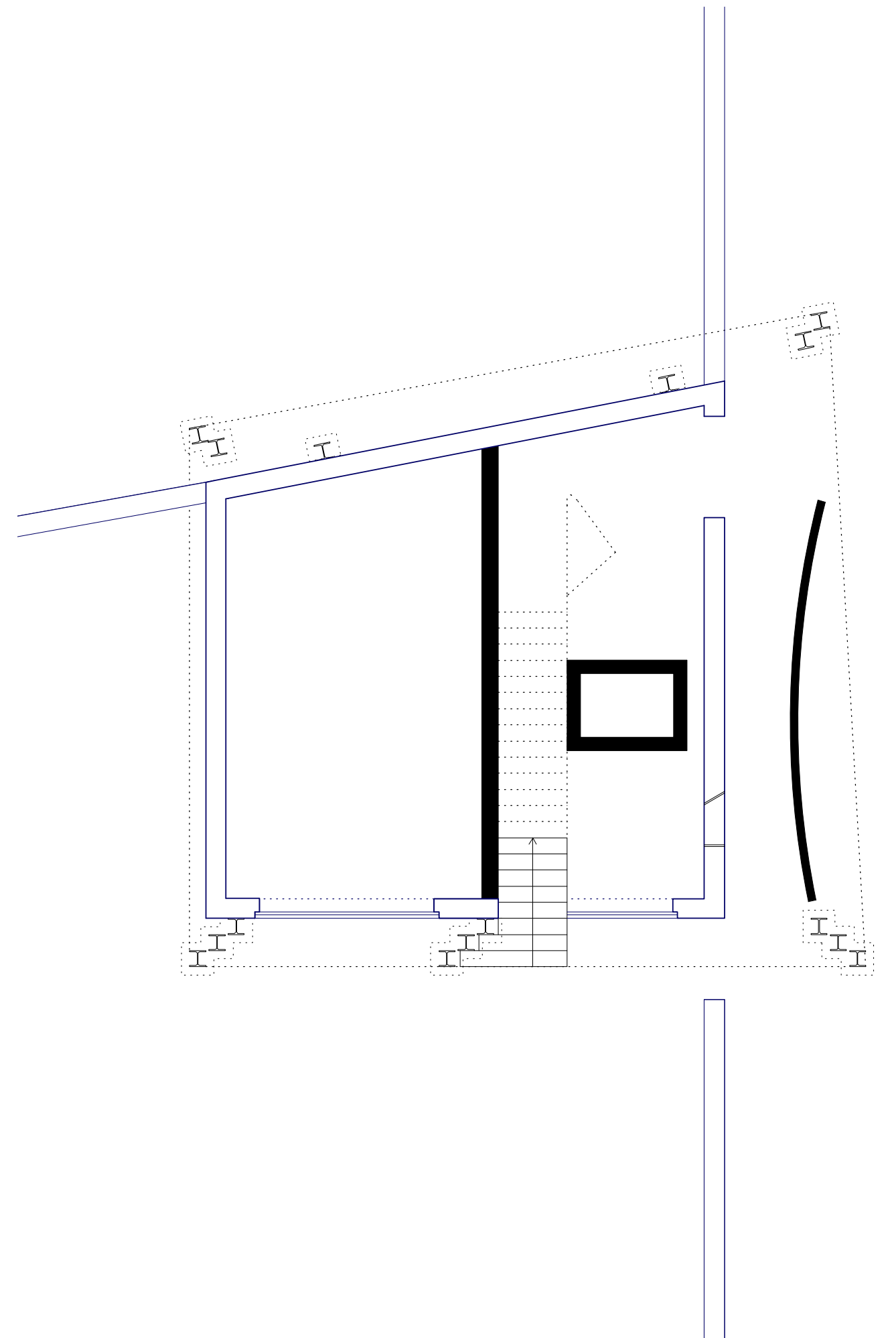
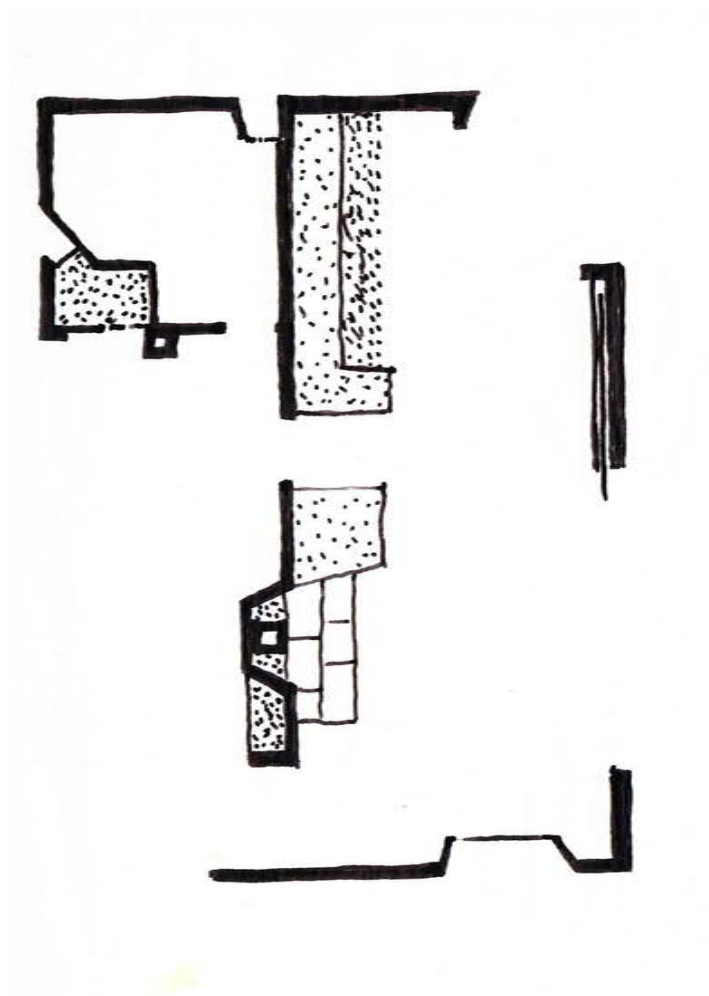
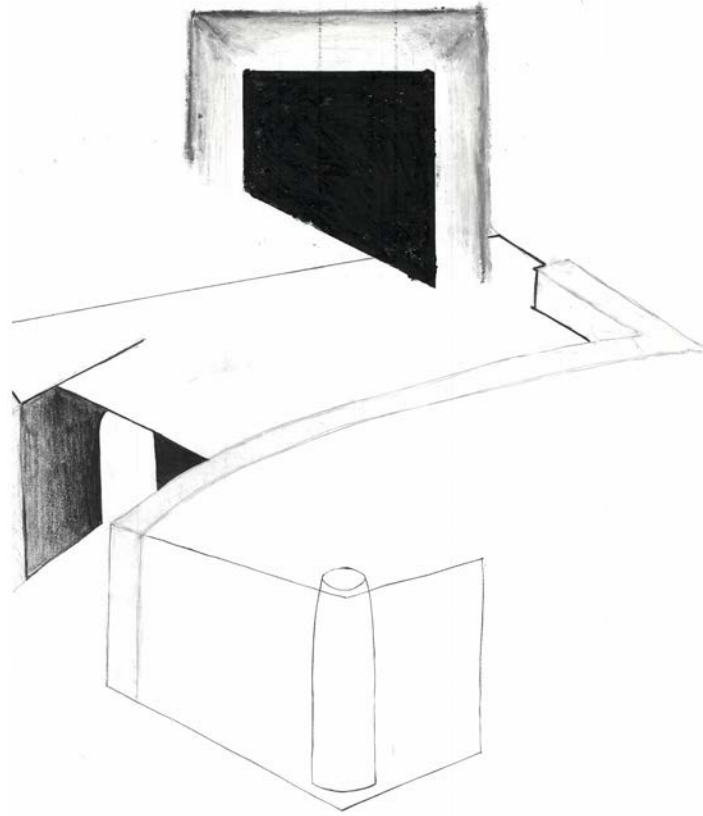

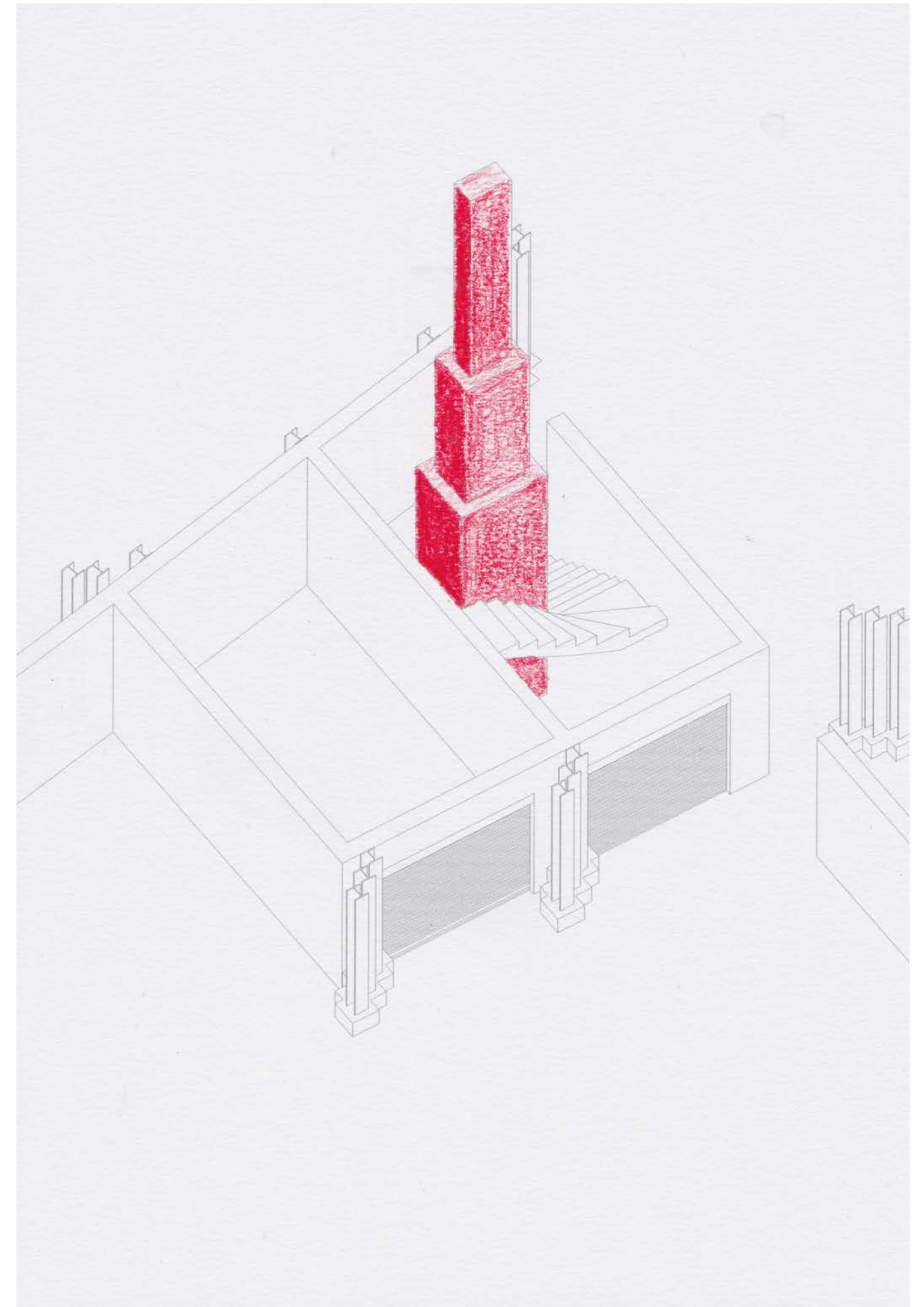
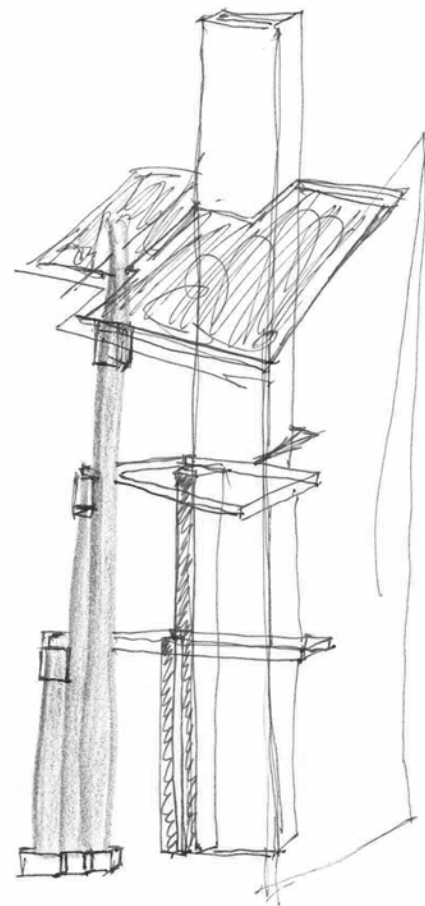

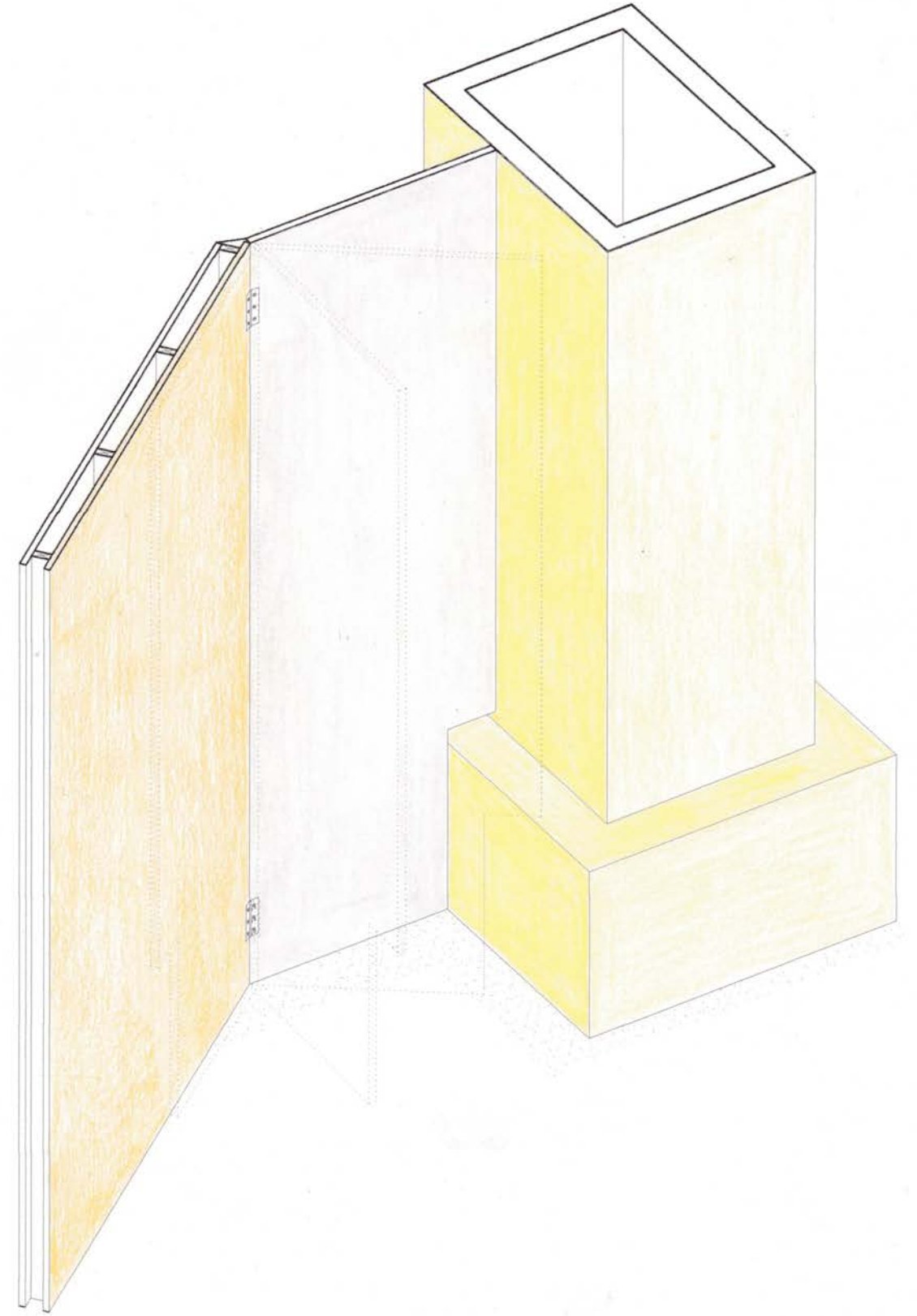





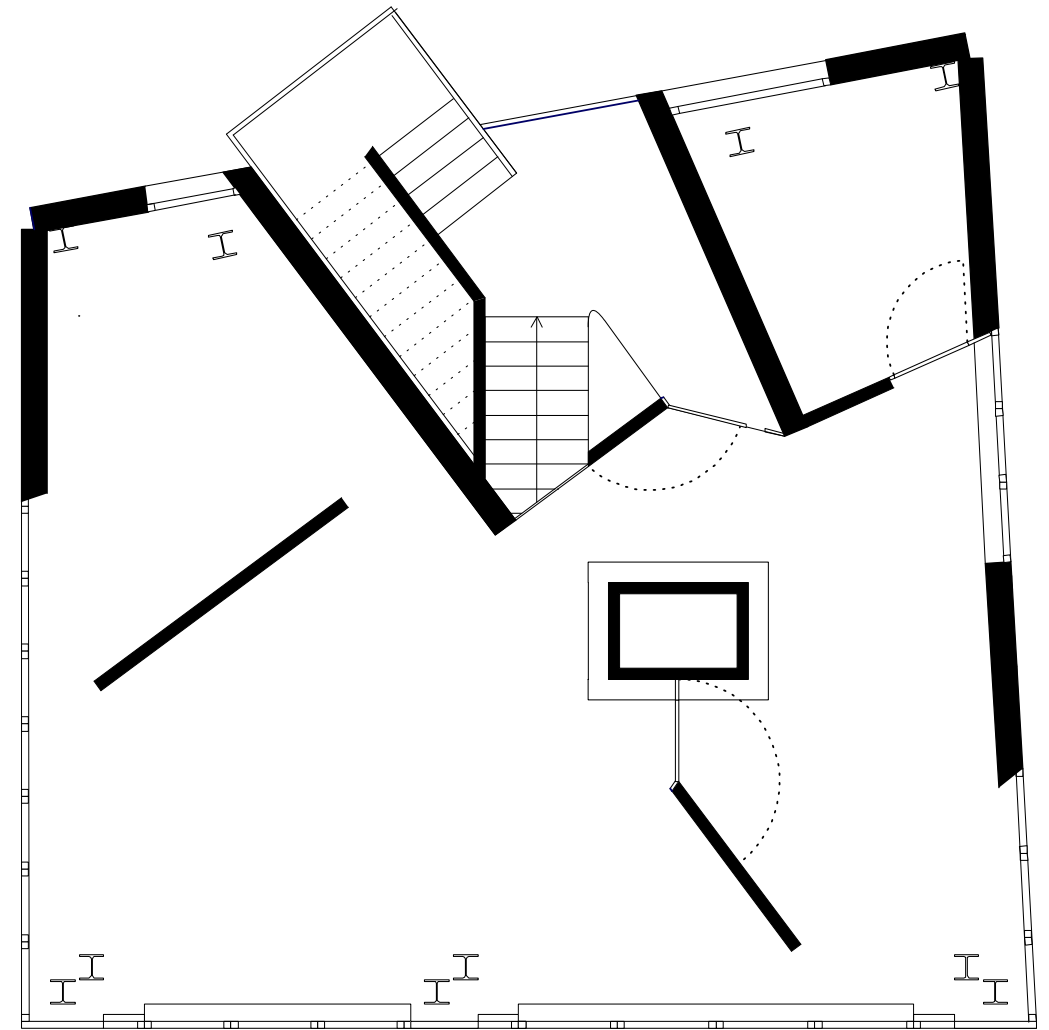

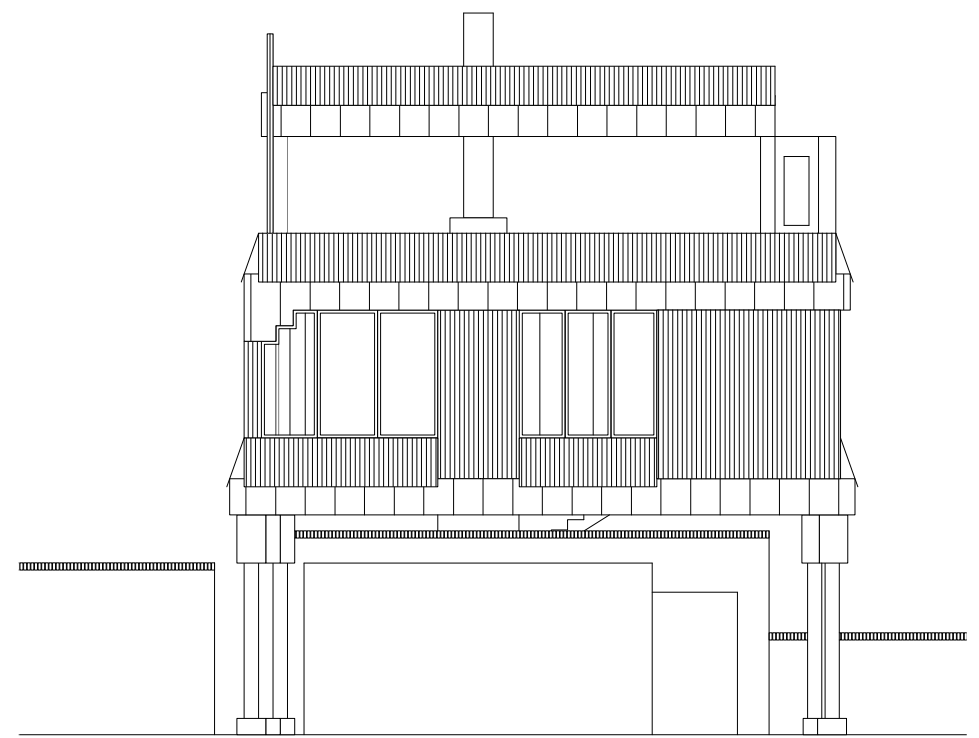
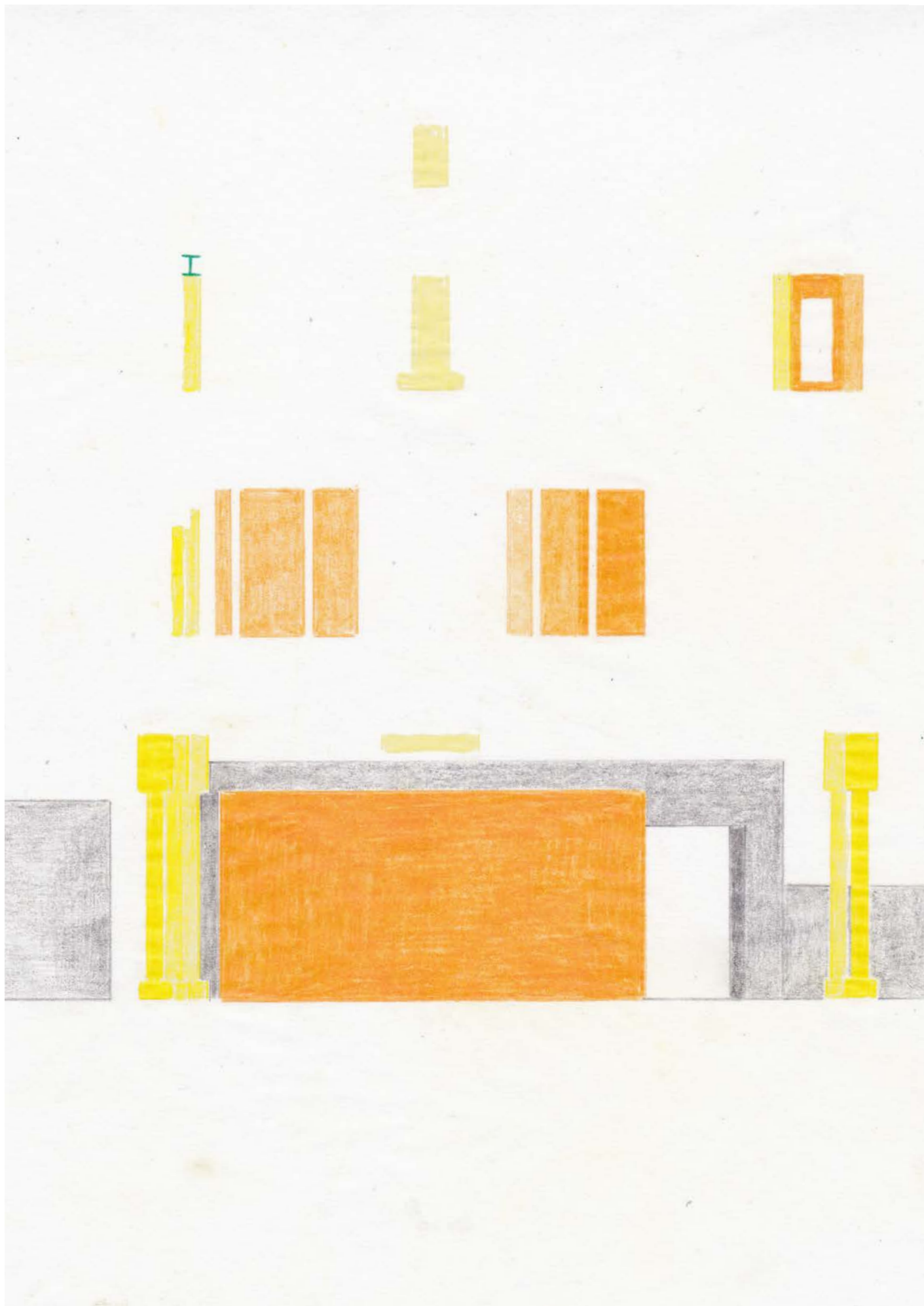



## In-betweens

We share this little guest house.  
It is in-between.

In-between house and garden,  
in-between neighbours,  
in-between wall and window,  
in-between structure and wall,  
in-between sharp flatness  
and plasticity

These rooms are in-between privat  
retreat and a place to celebrate.

Staring at the facade I know there is  
this little gab where the architect ones  
forgot to put the cladding.  
There, in-between, a little sparrow  
couple is having its nest.

This space is in-between the ground,  
the existing and the sky.







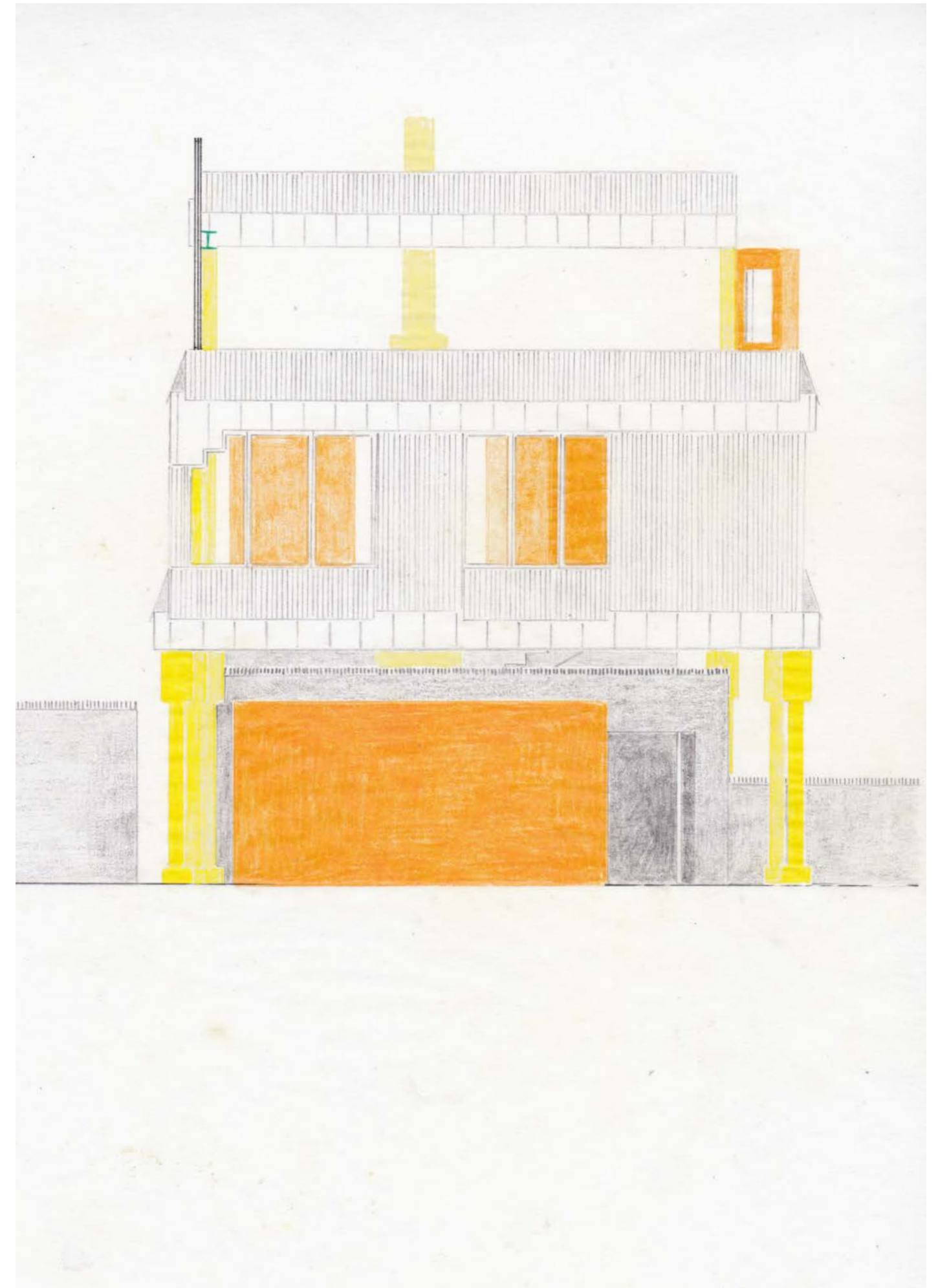
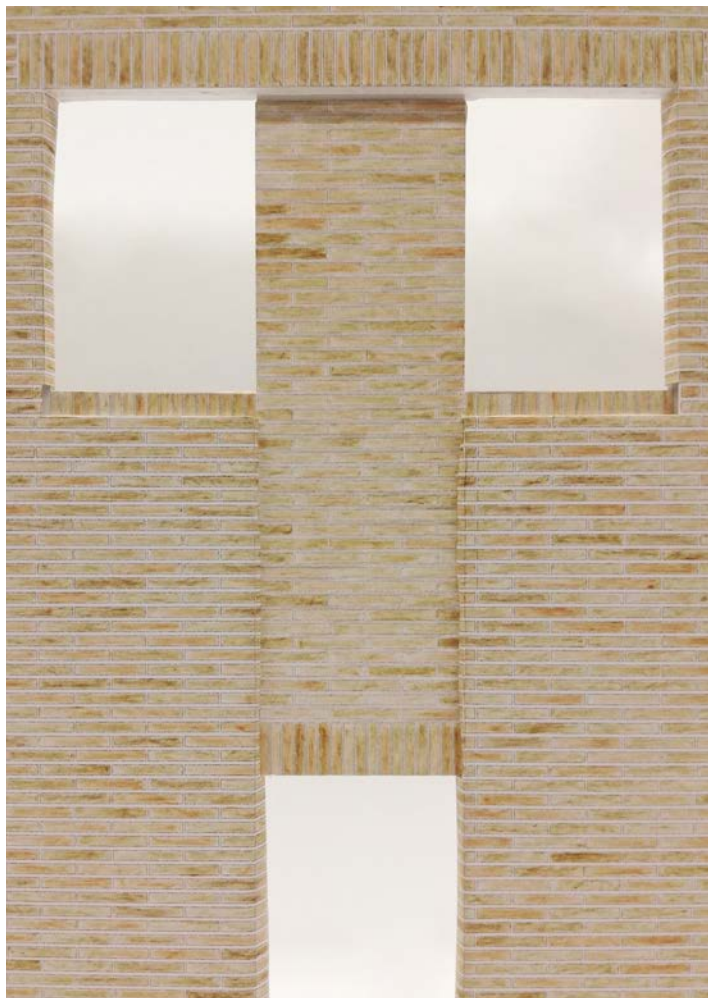

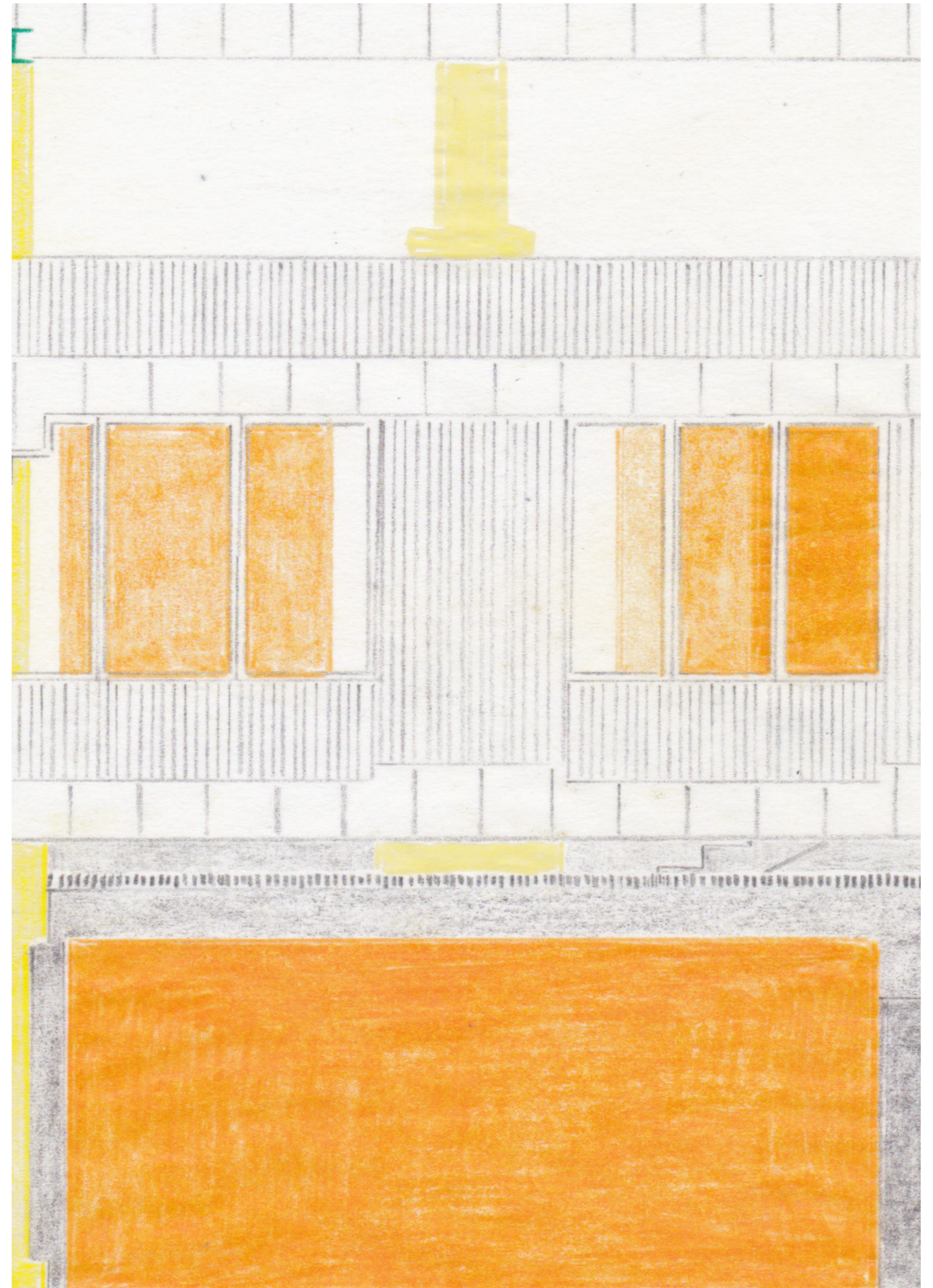
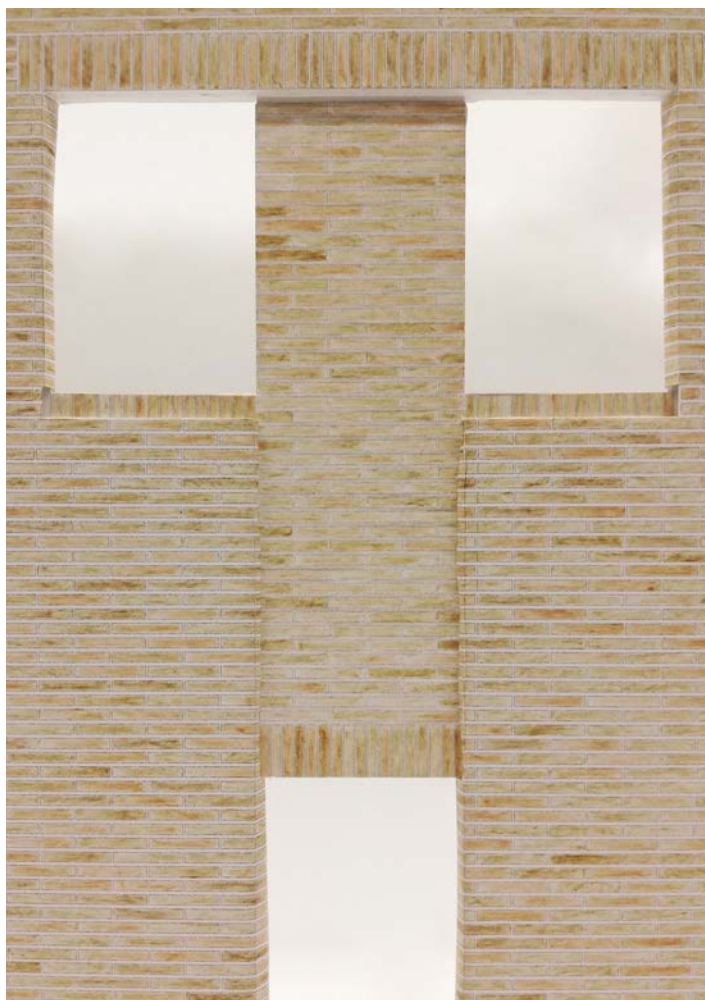





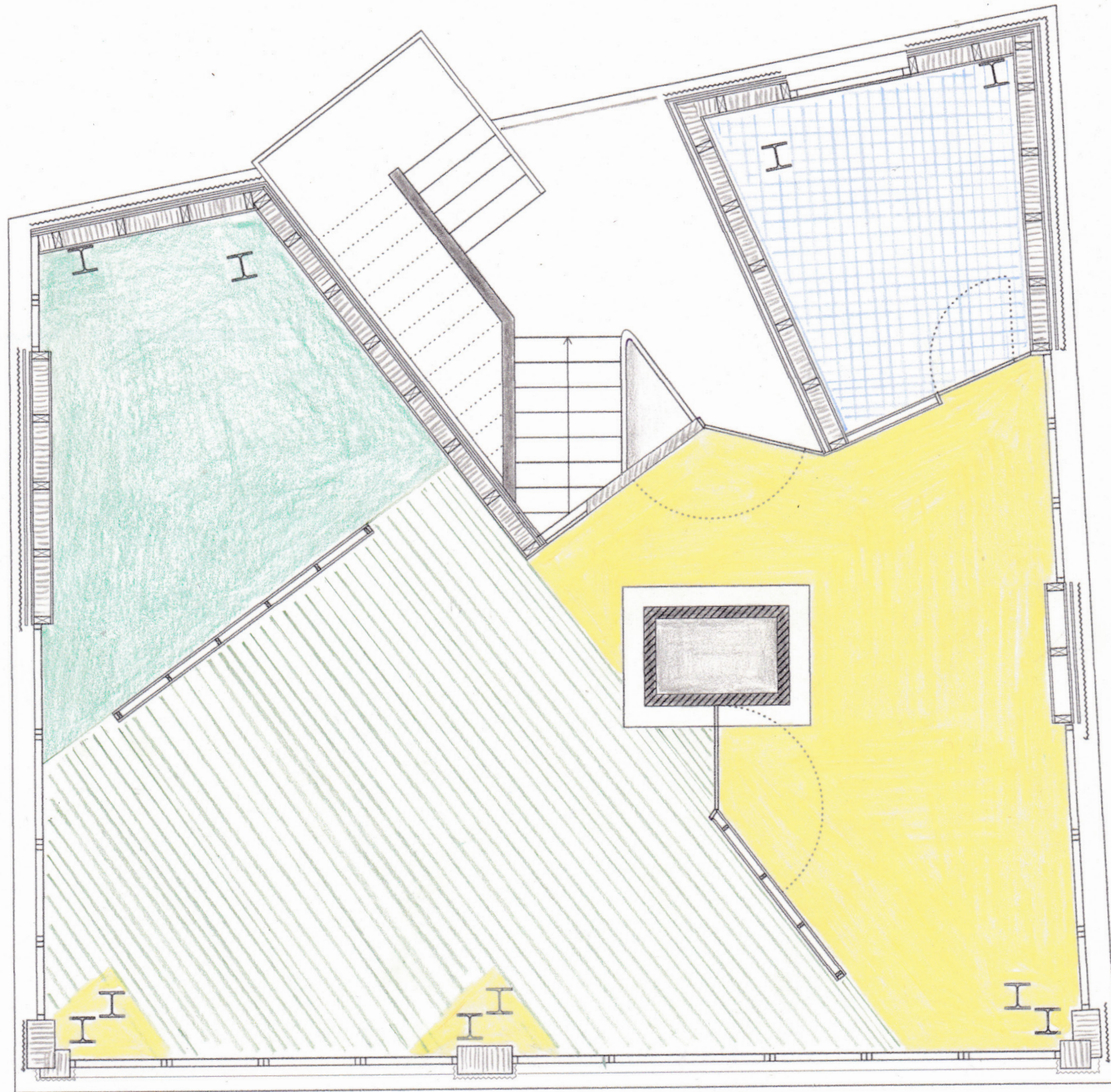



# Dialogue



# Dialogue

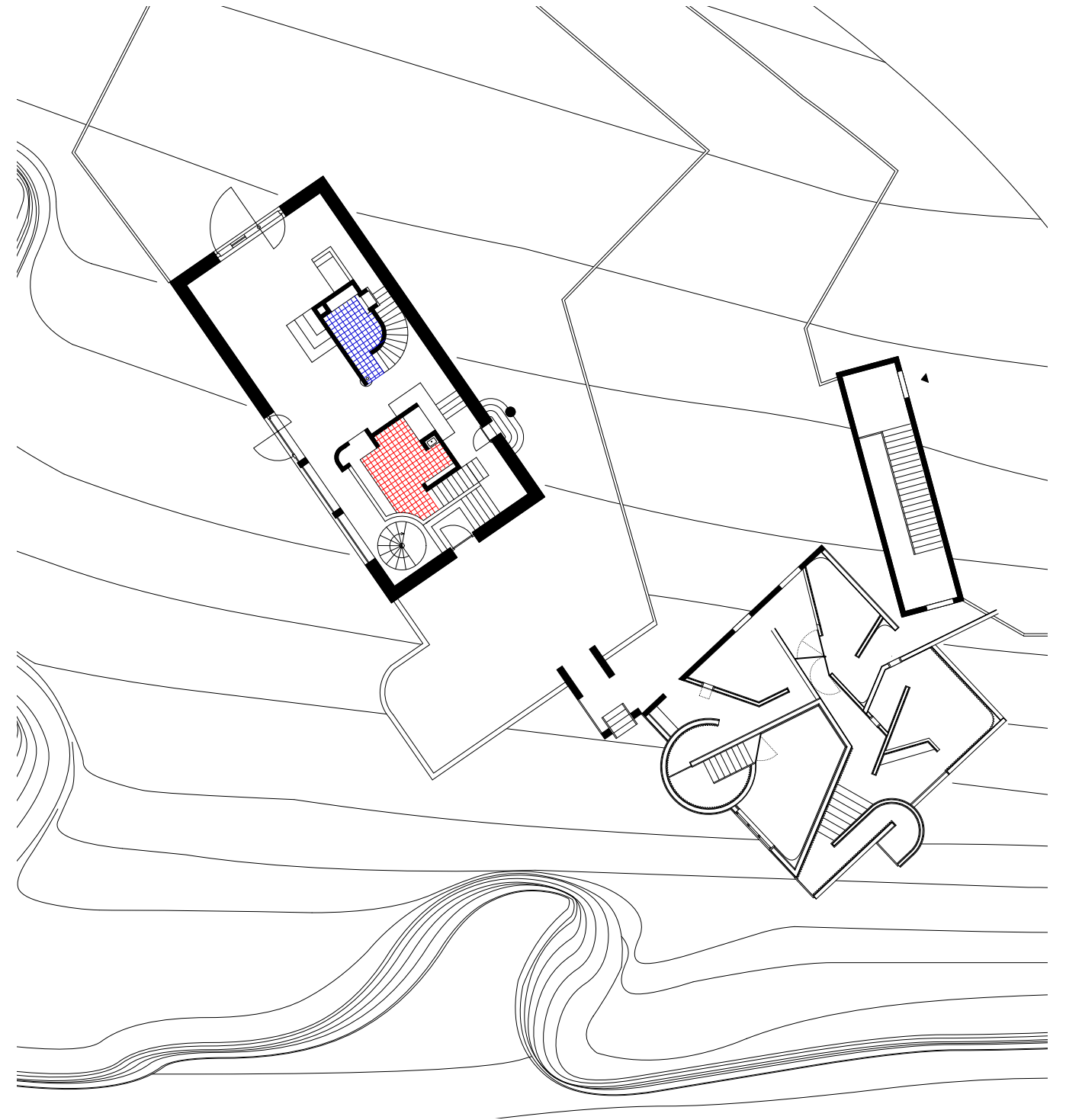
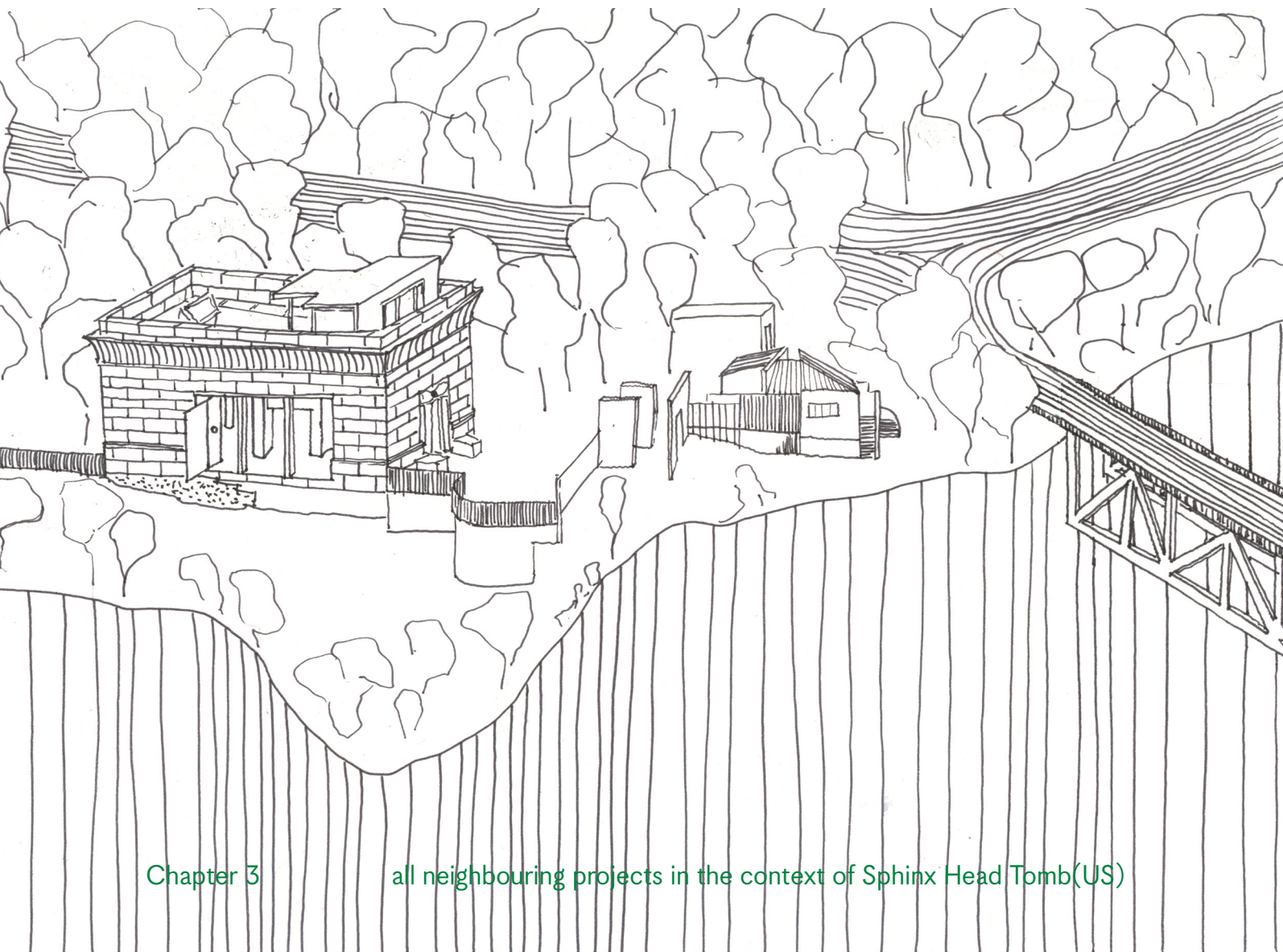

# Dialogue



A

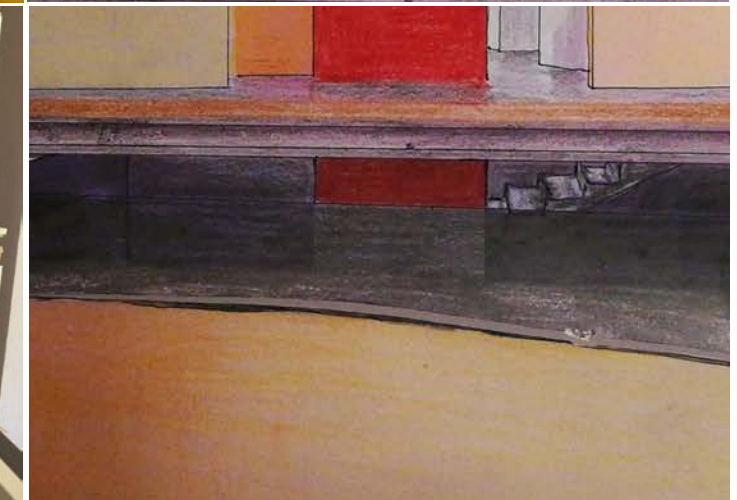
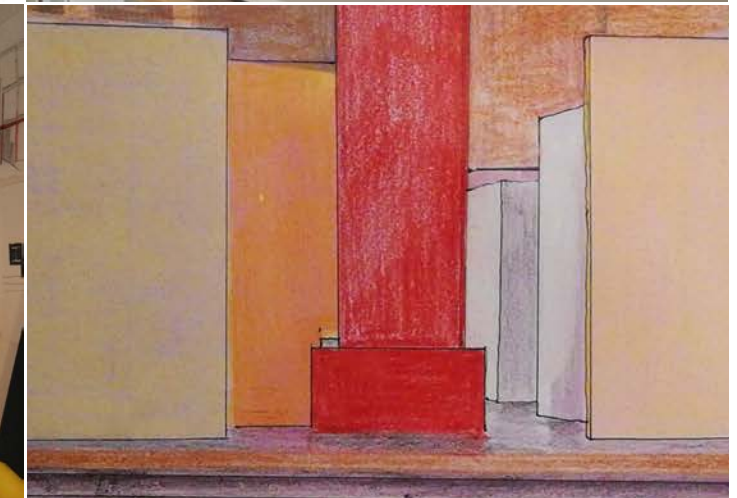
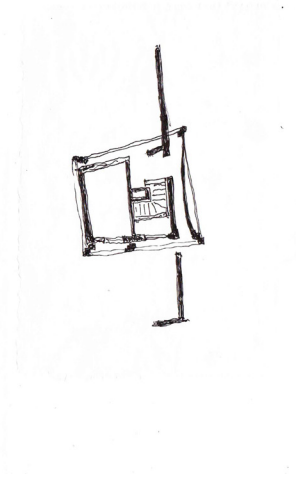

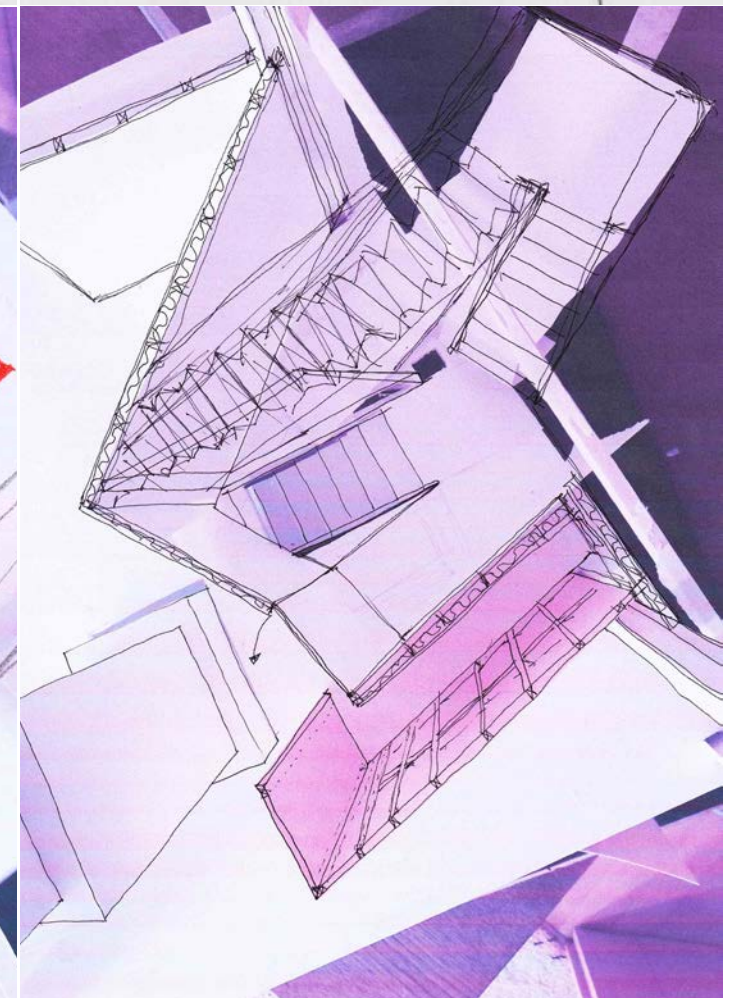
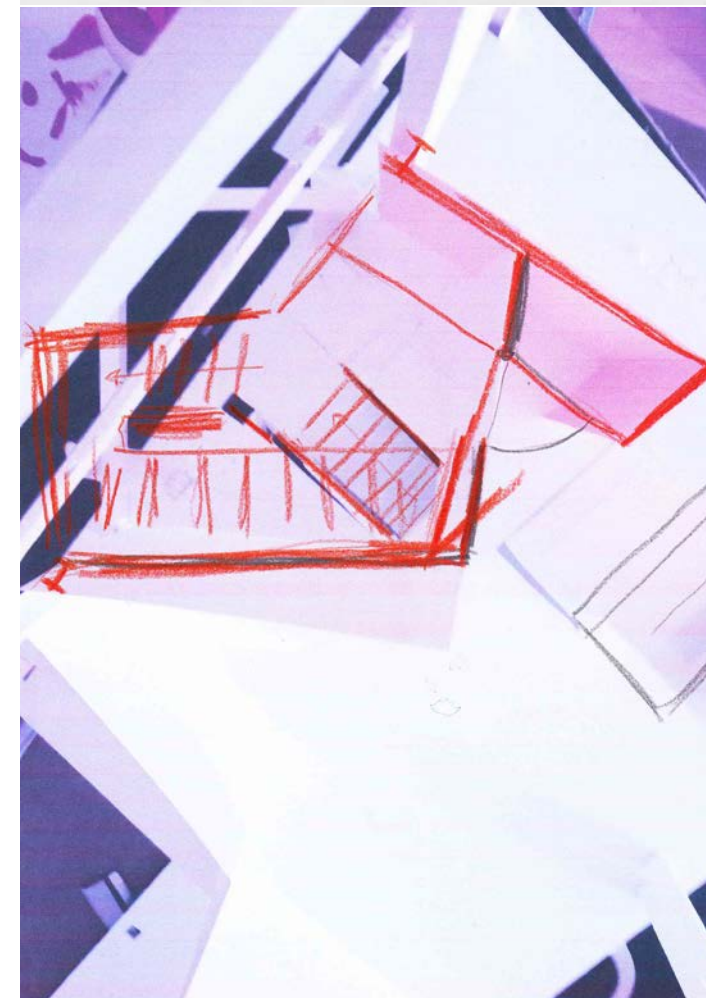
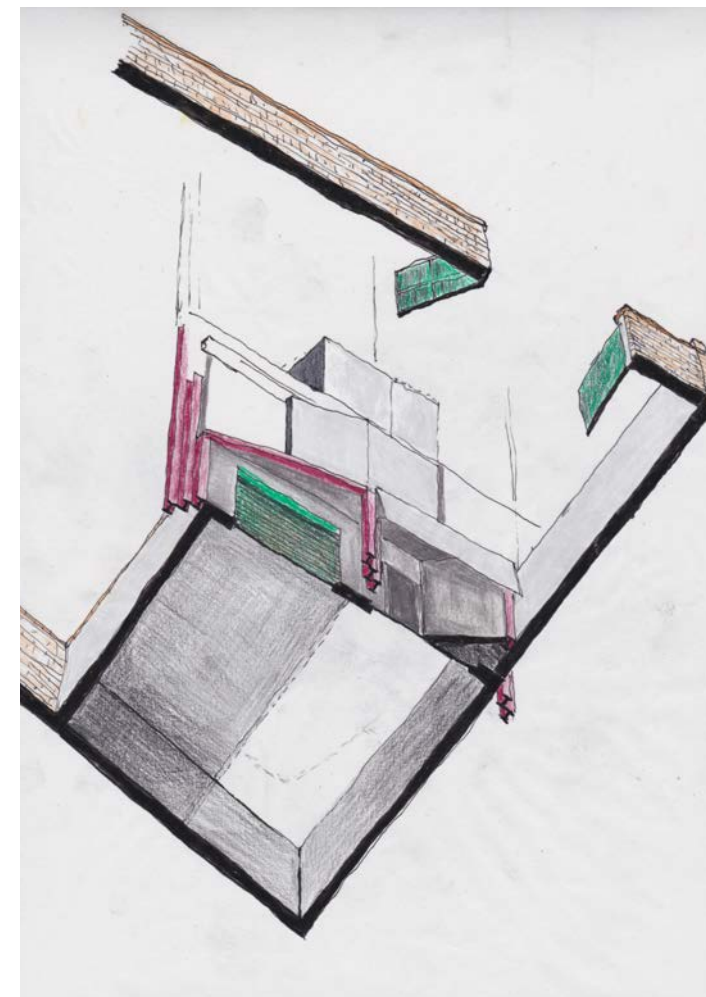
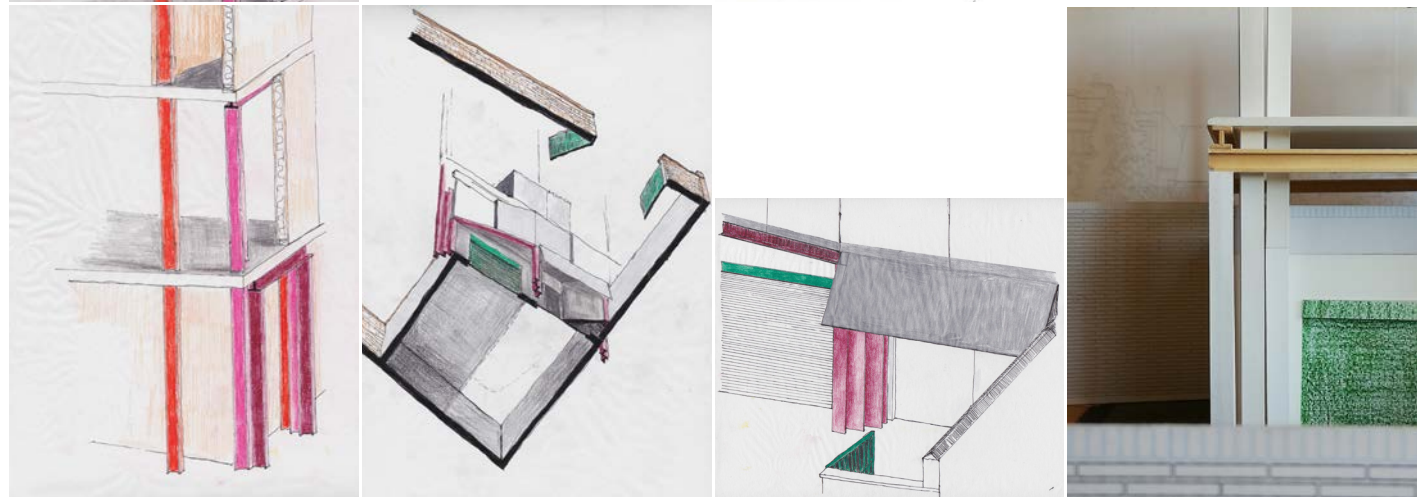
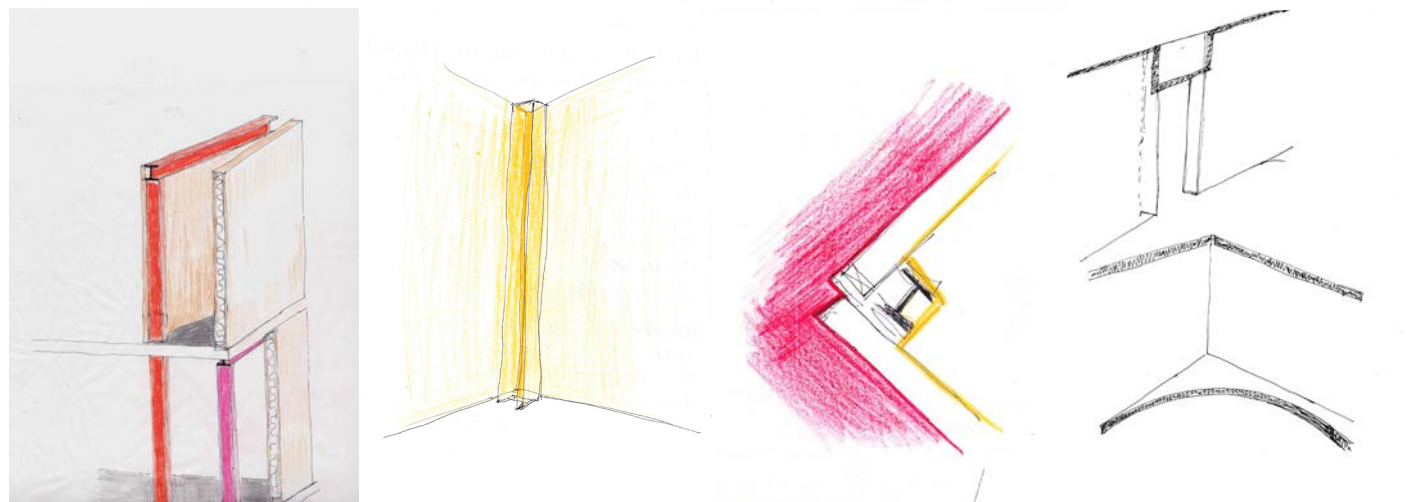
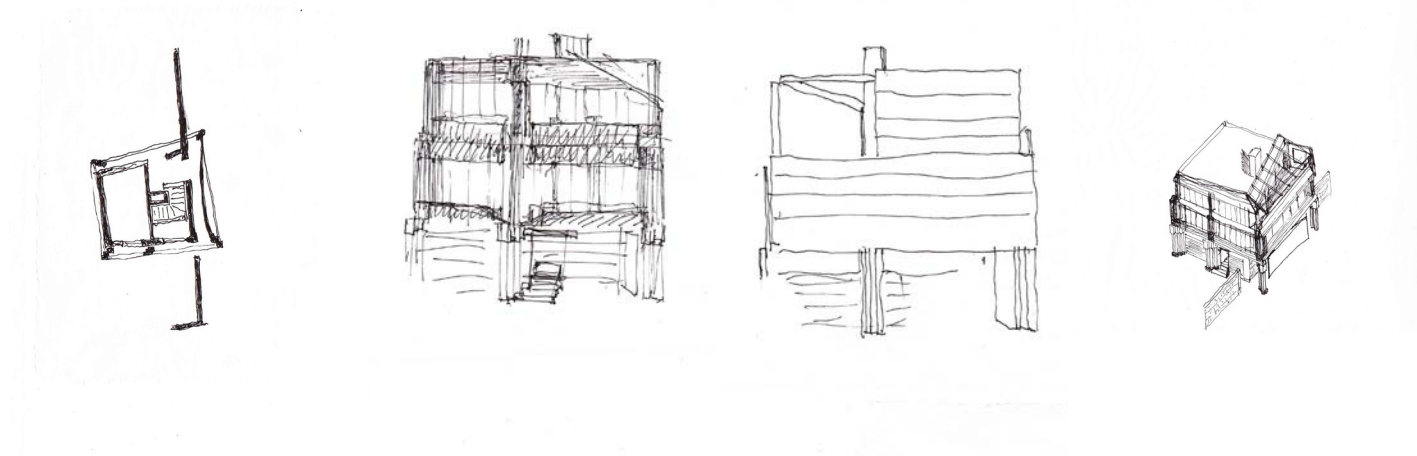
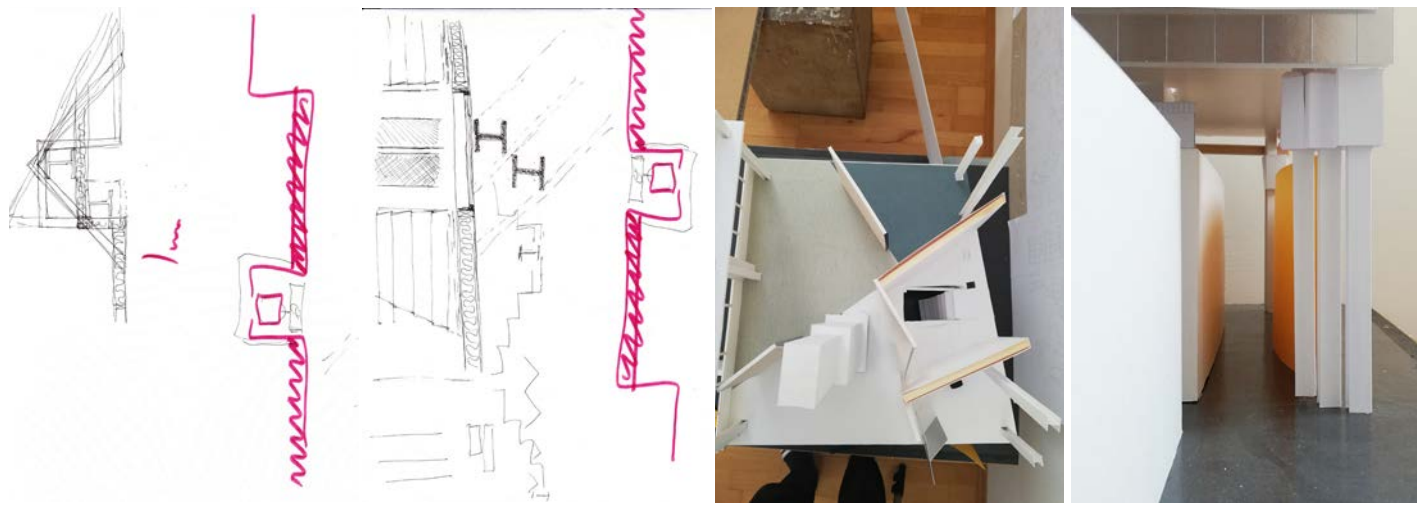



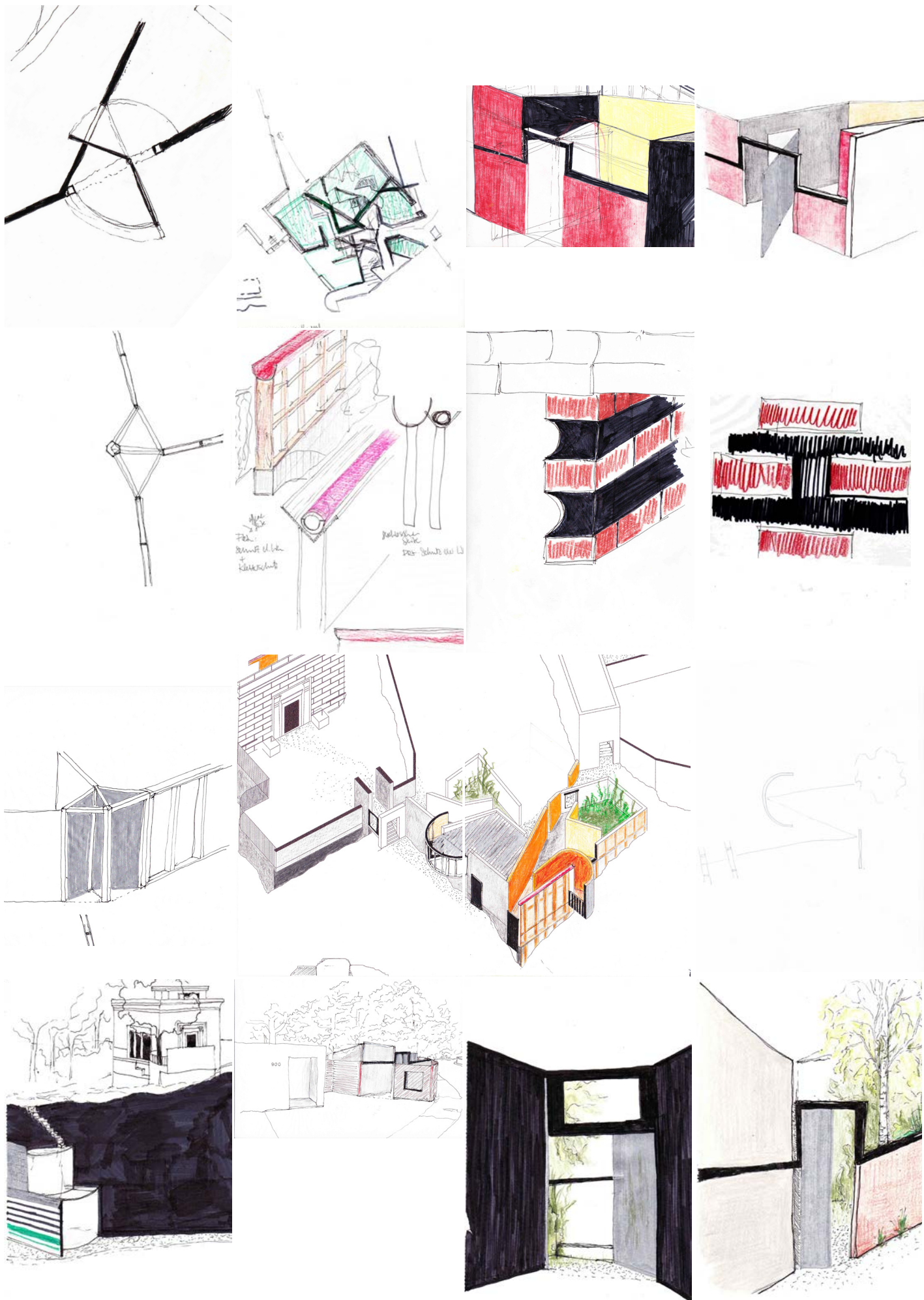

Archive



Heuer, Henrike



A

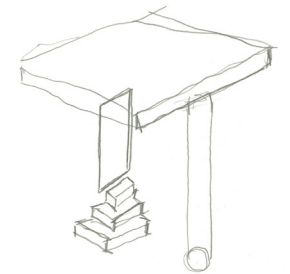
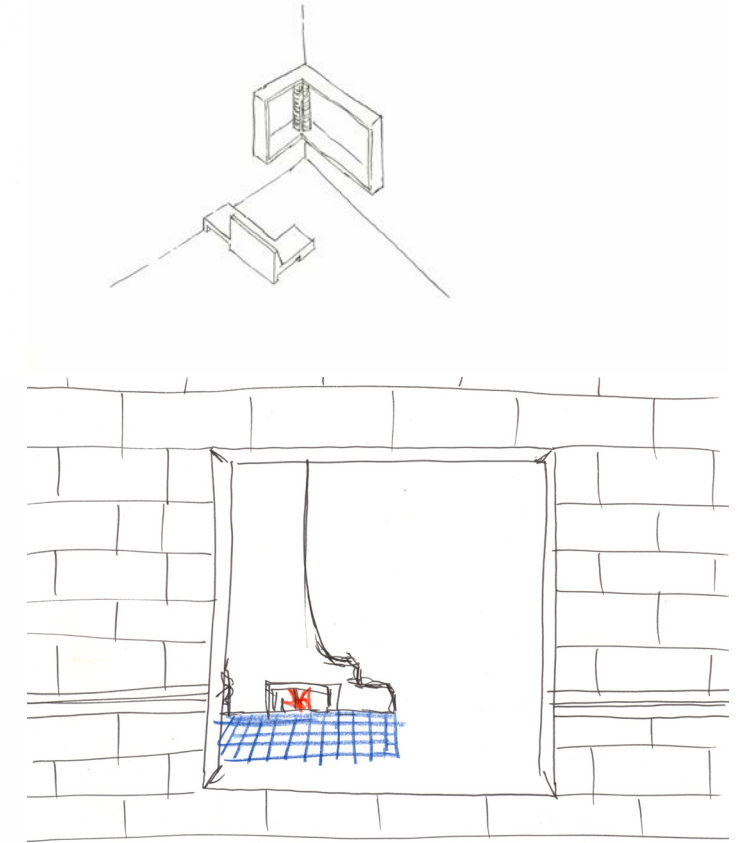
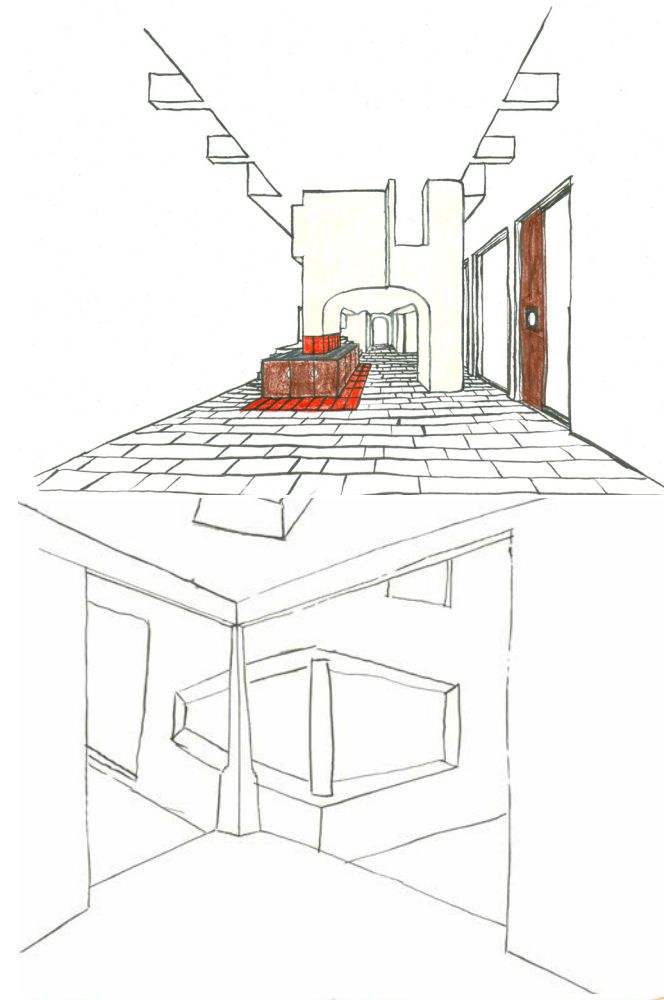
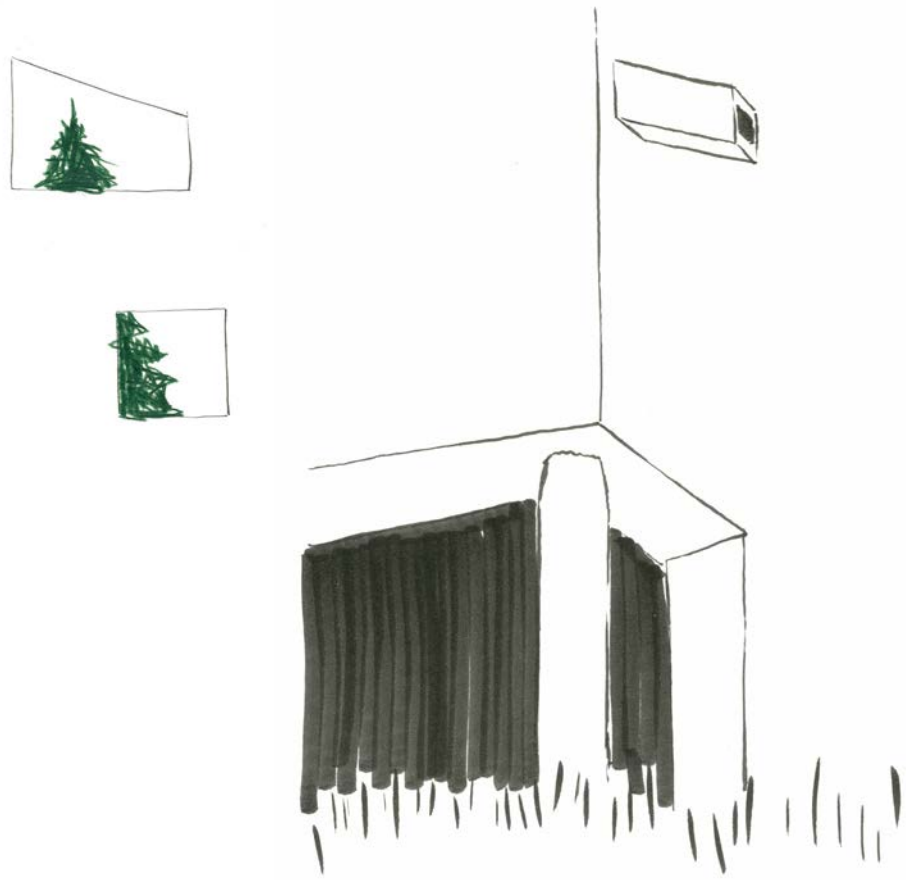

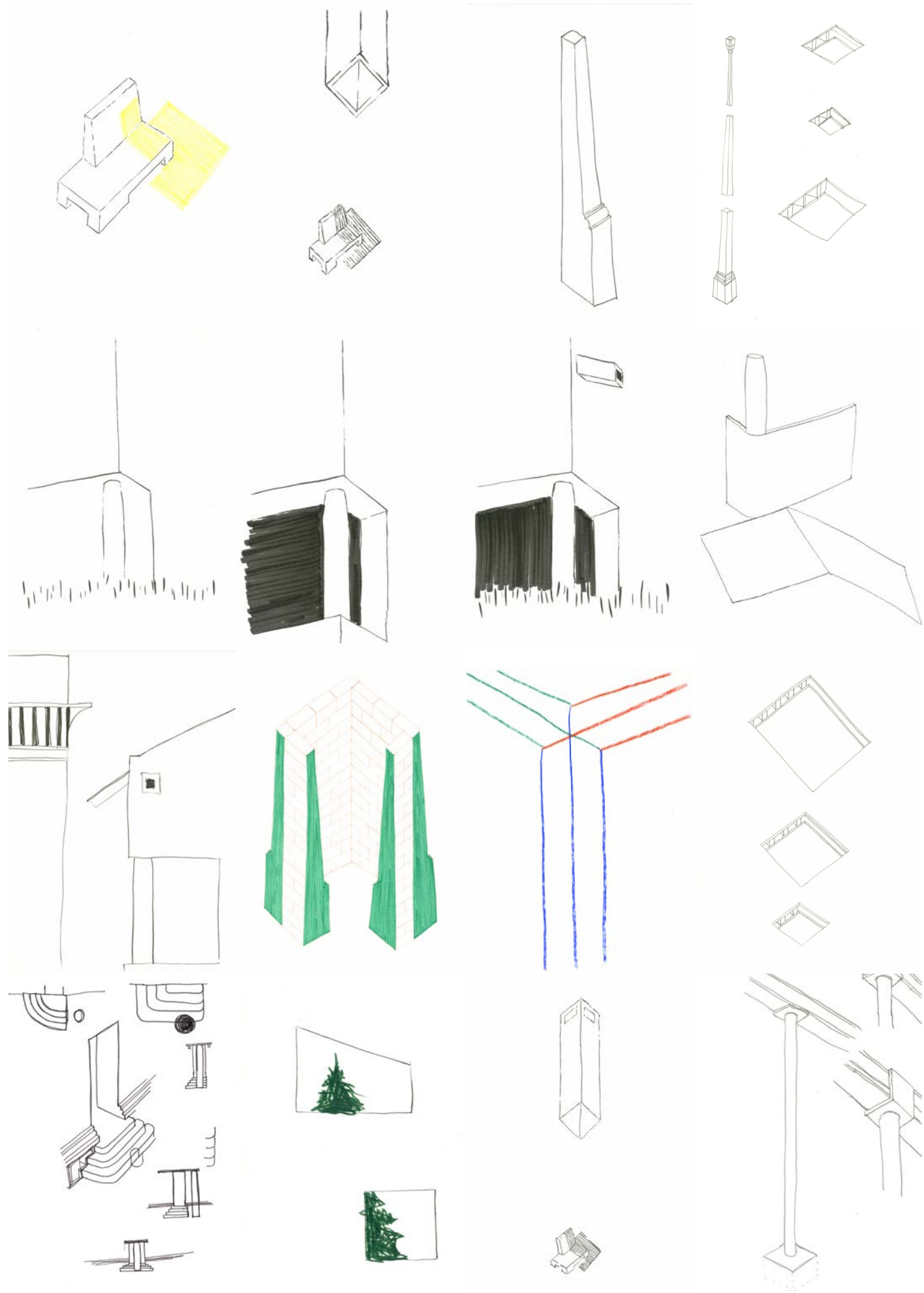

Archive



Weber, Carmino Laurin

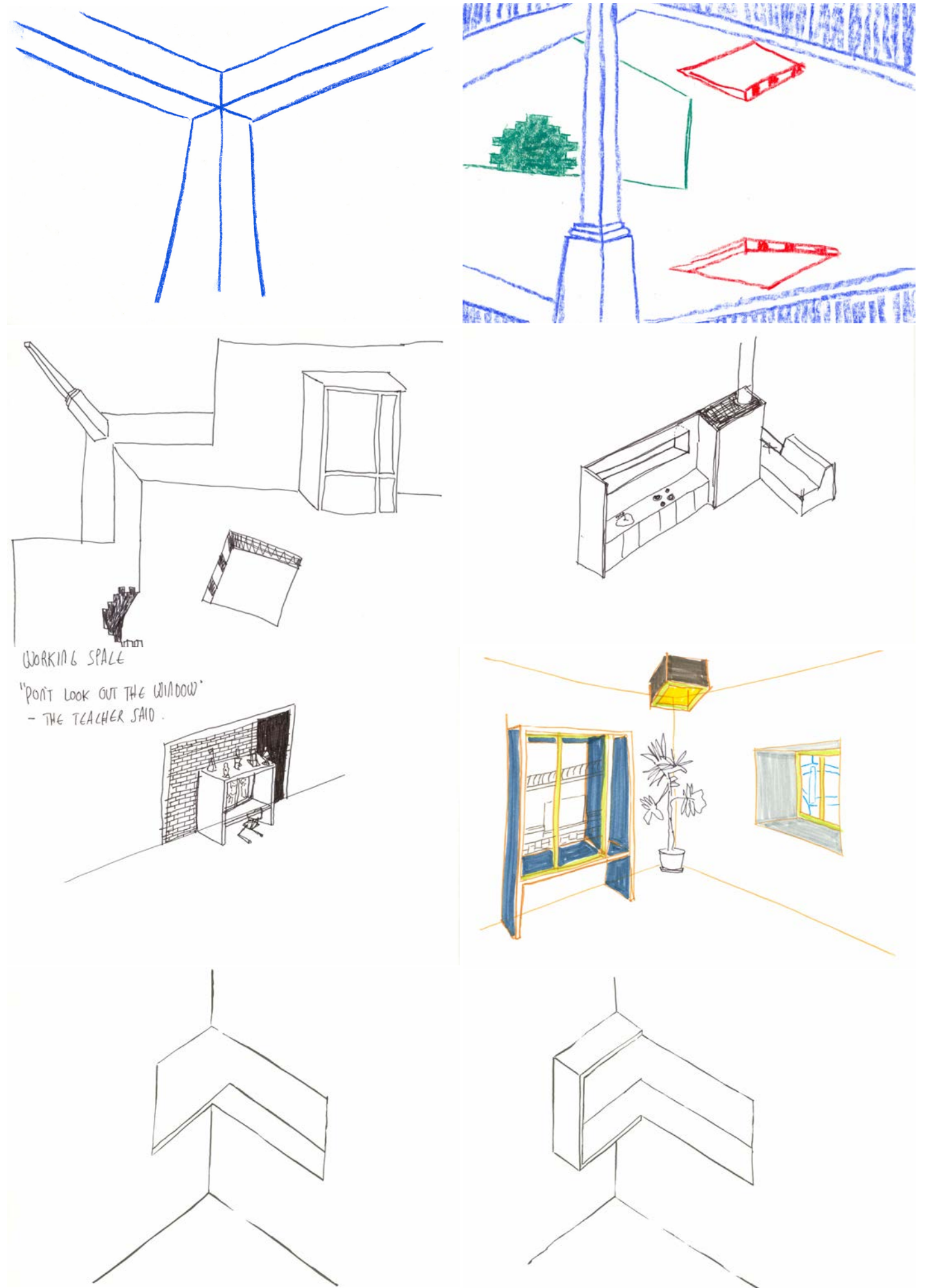
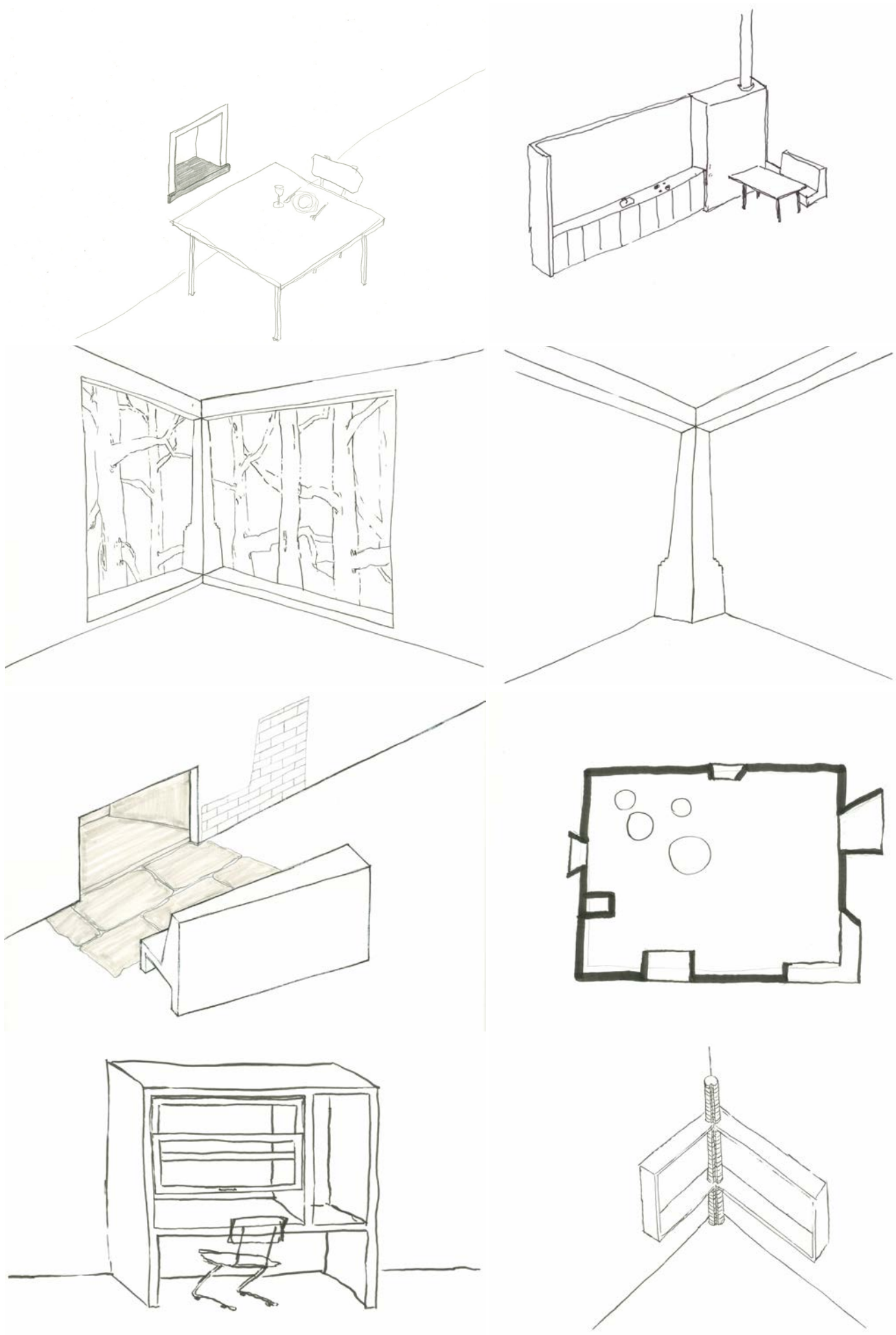

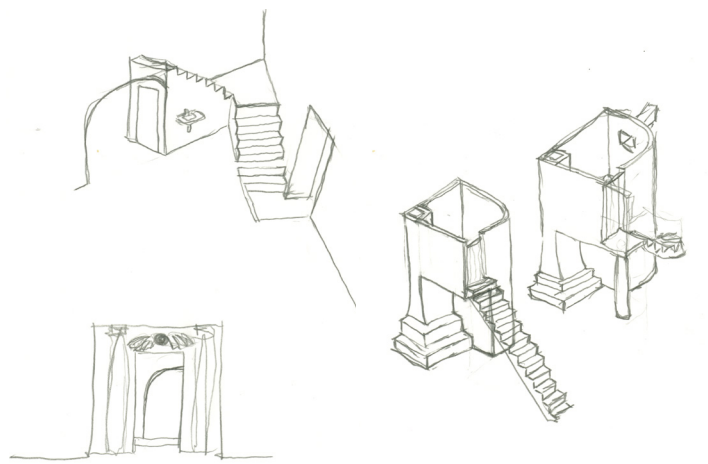
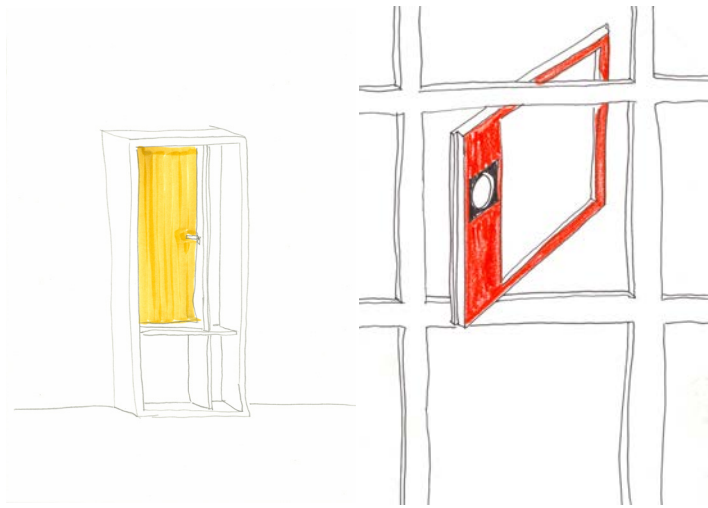

IVAC IN STUZZA

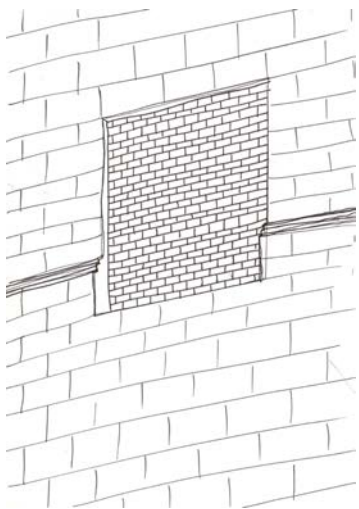

A

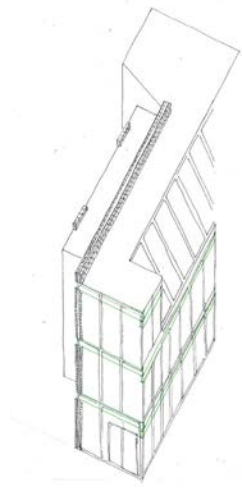

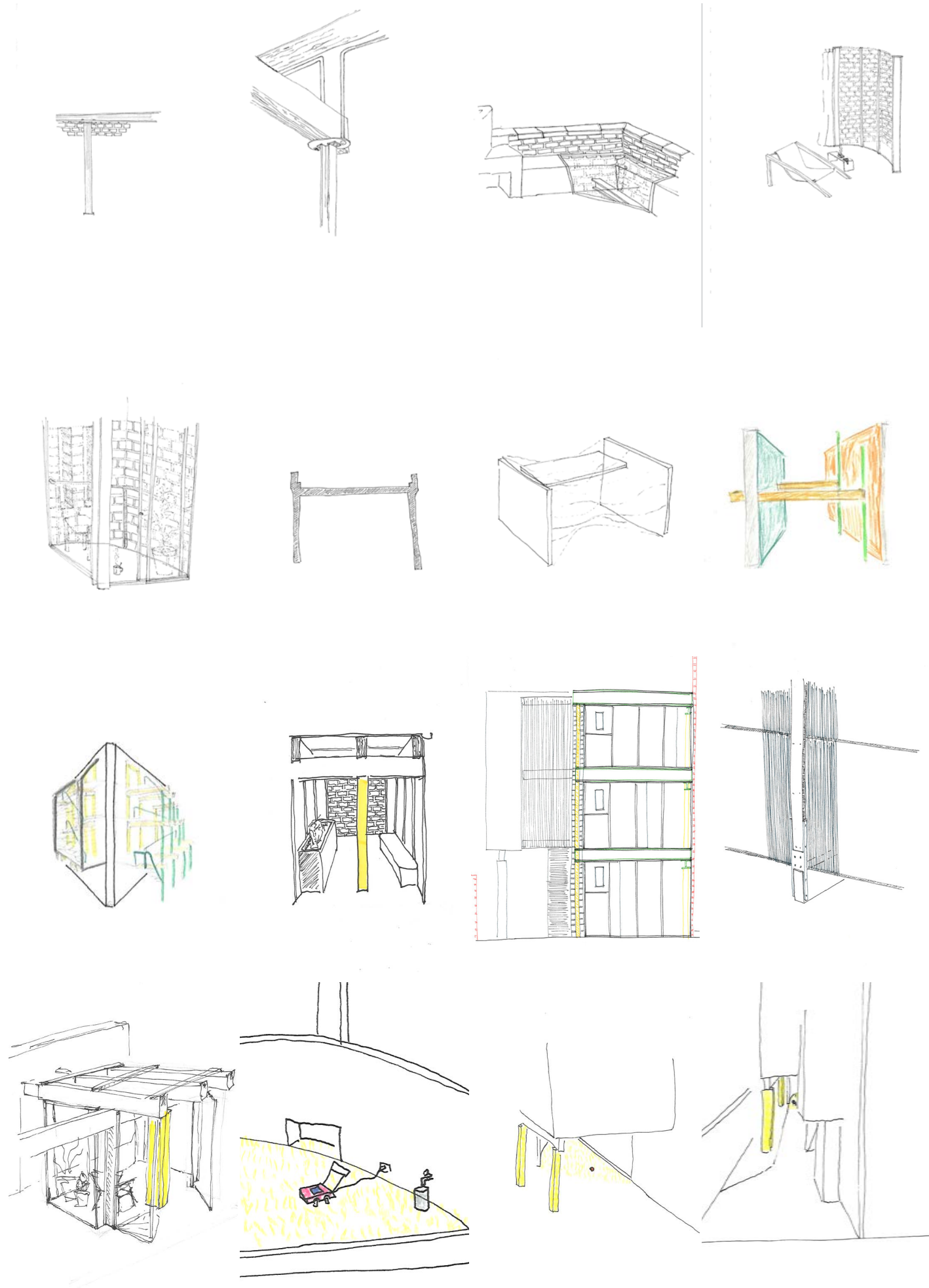

Archive

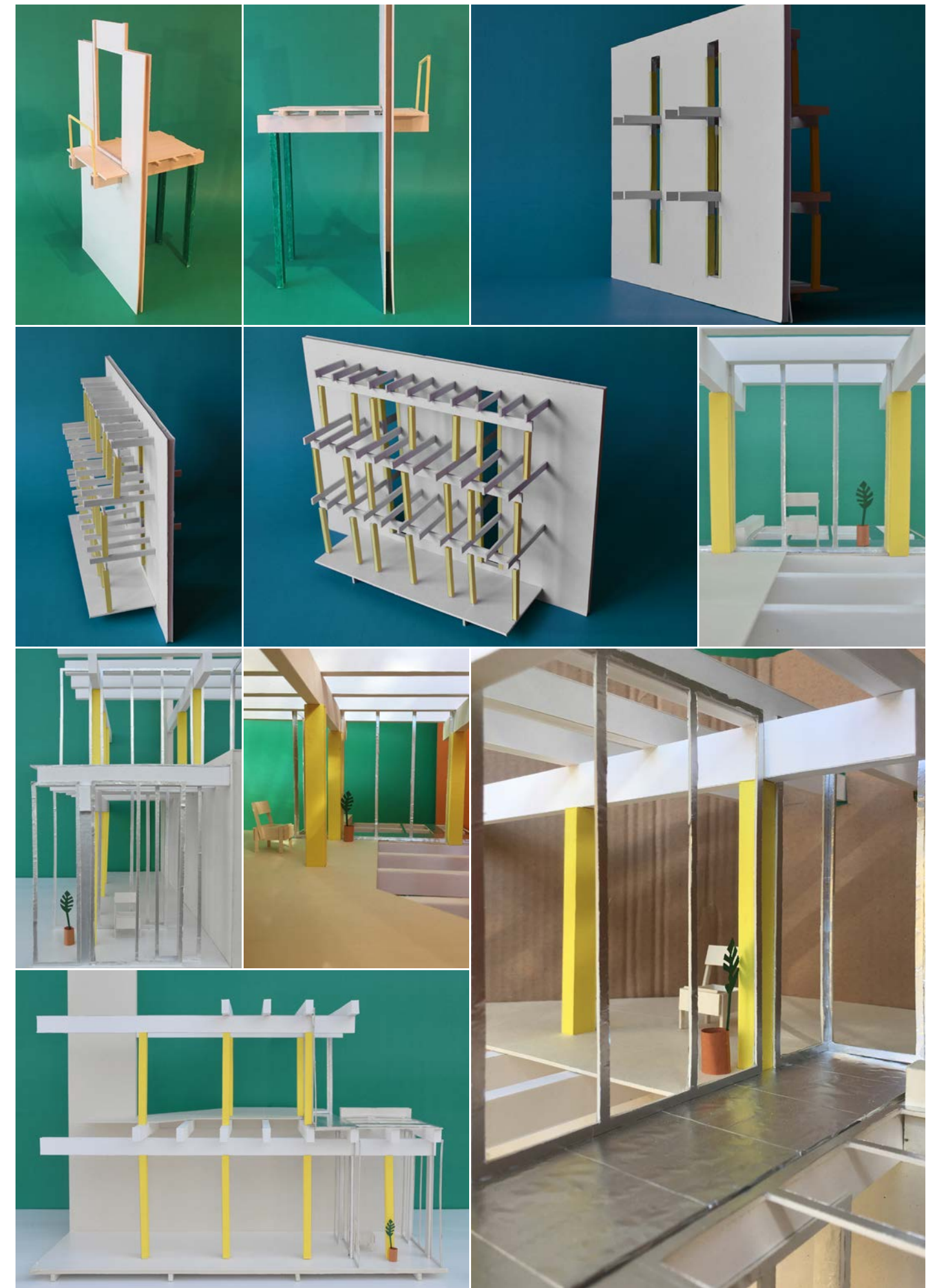

Vonder Mühl, Tobias



A

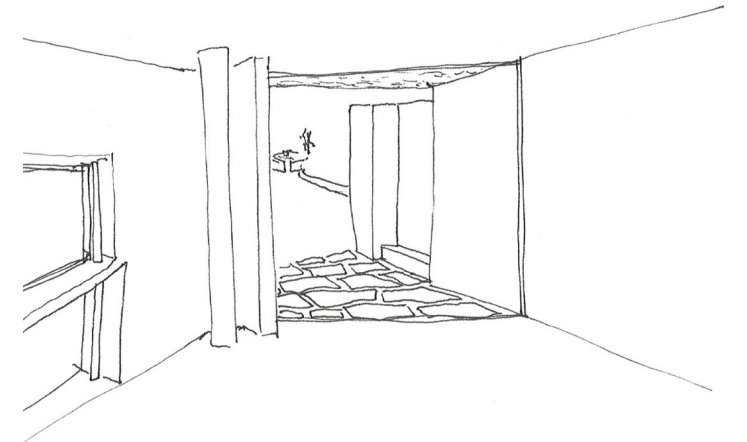
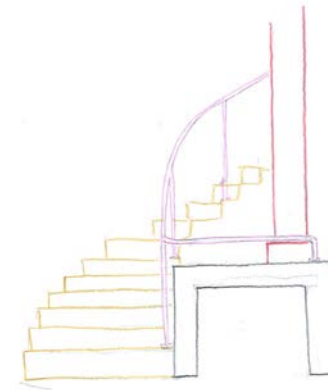
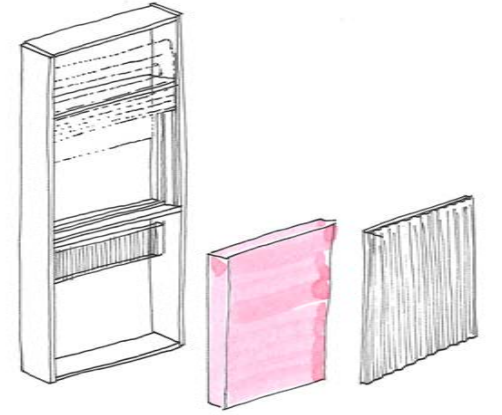
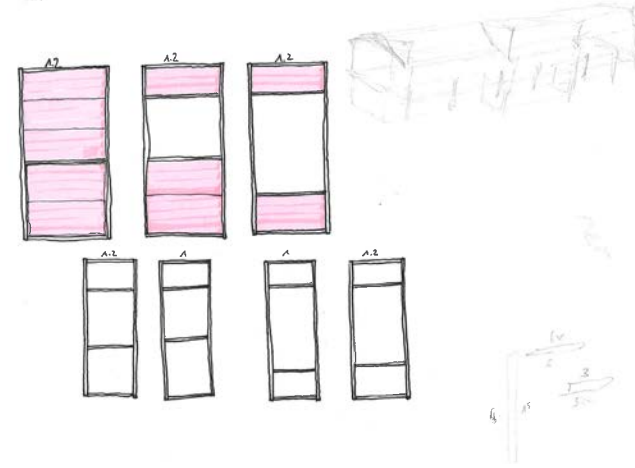
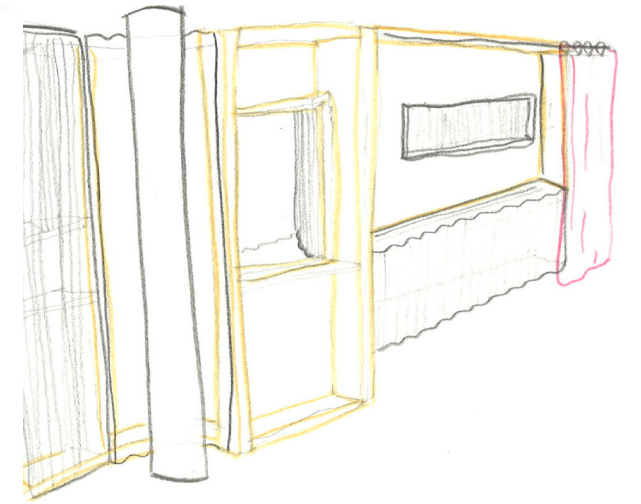
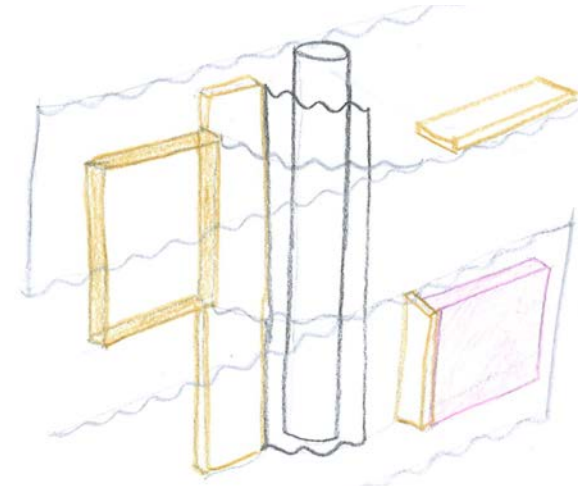
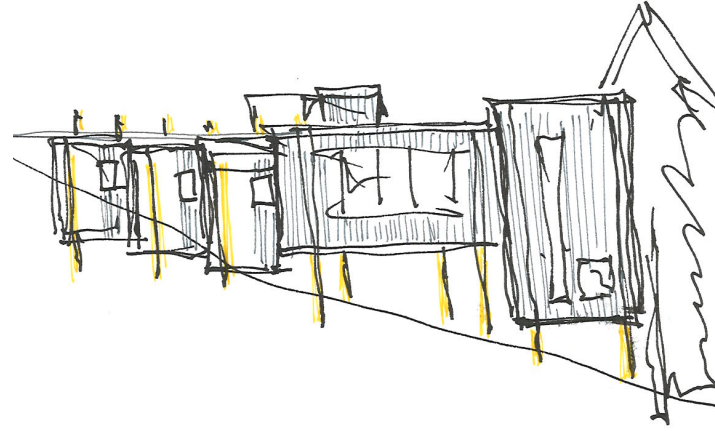
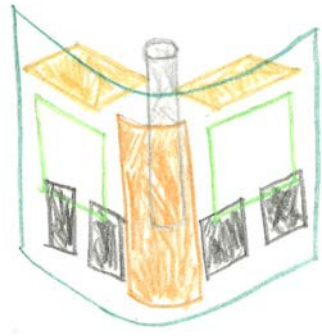

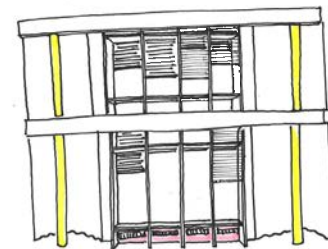
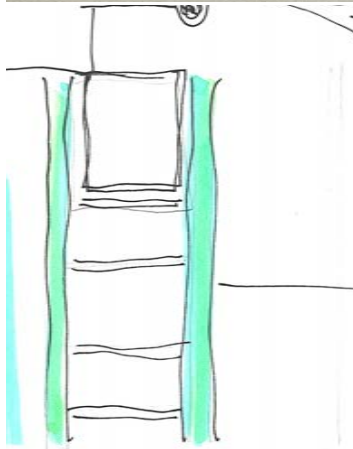
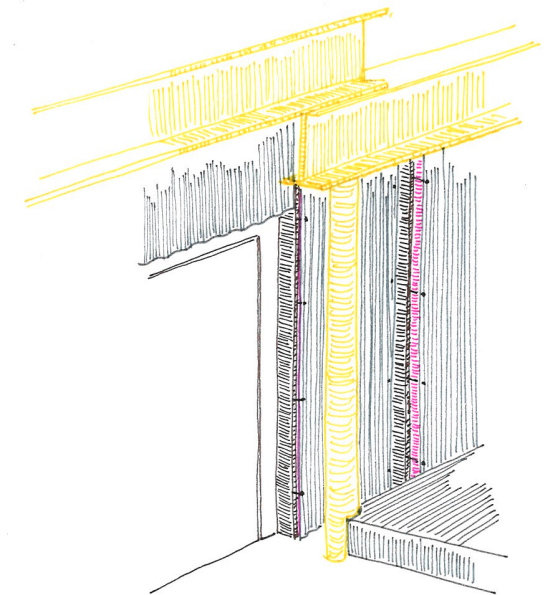
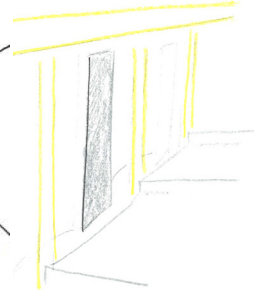
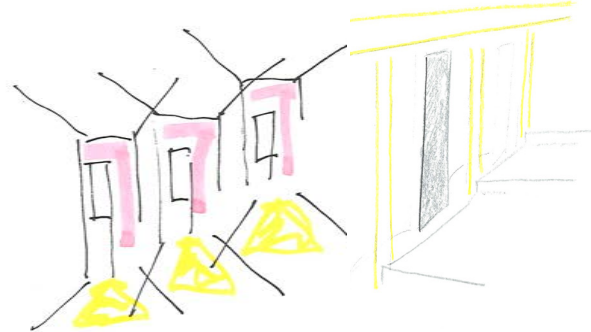
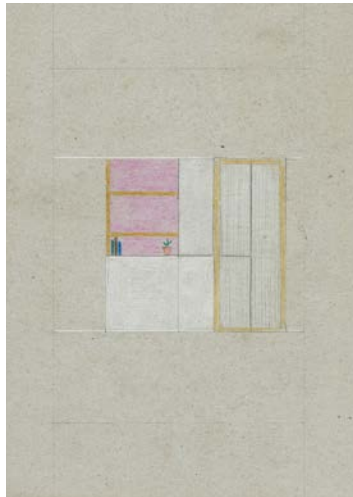
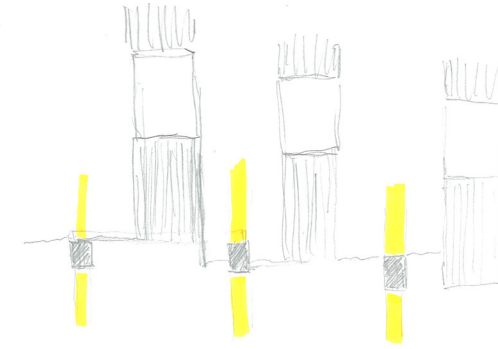
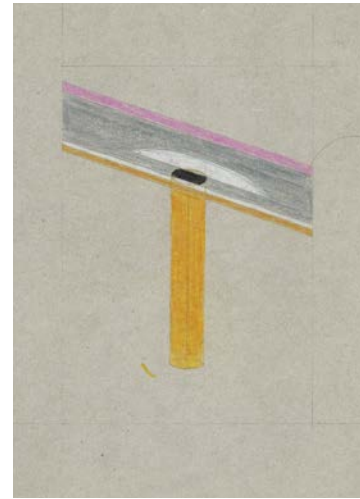
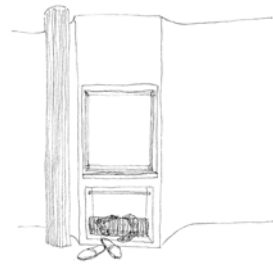
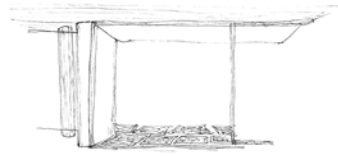
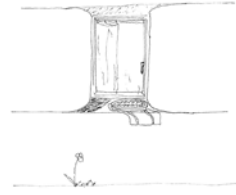
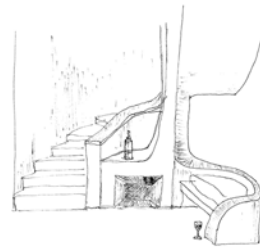
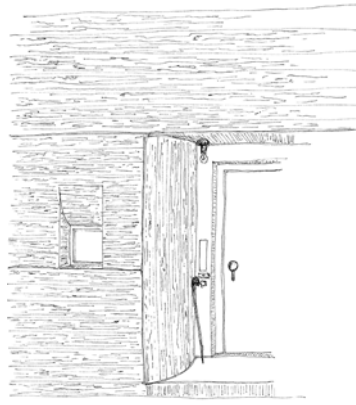
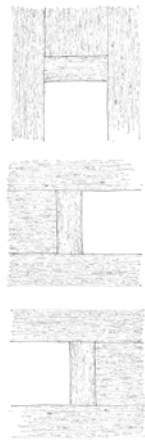

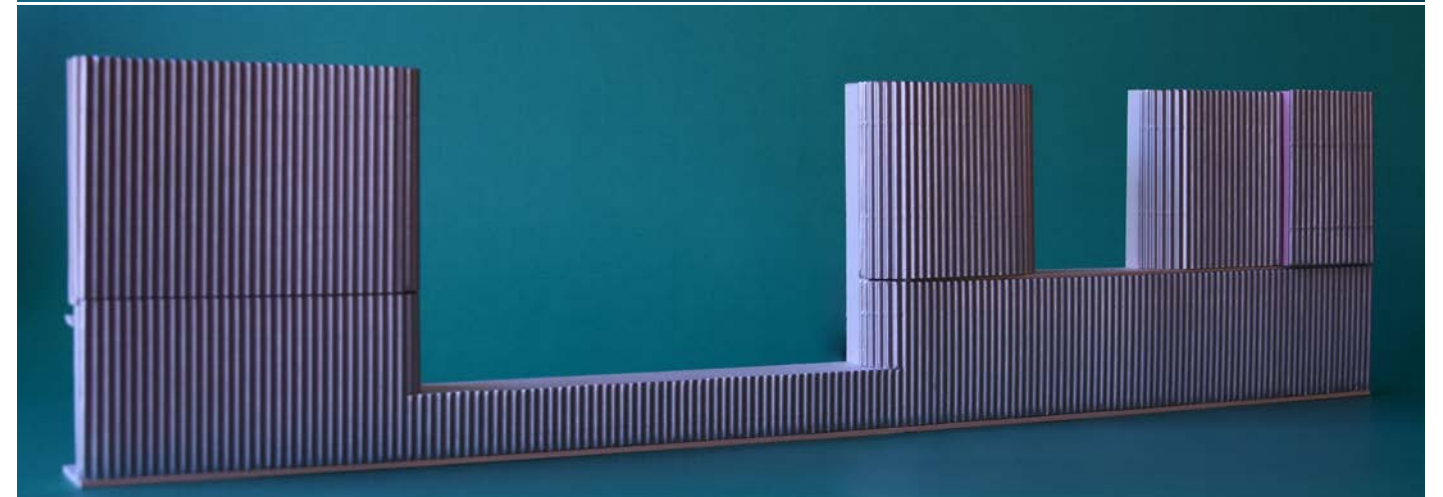
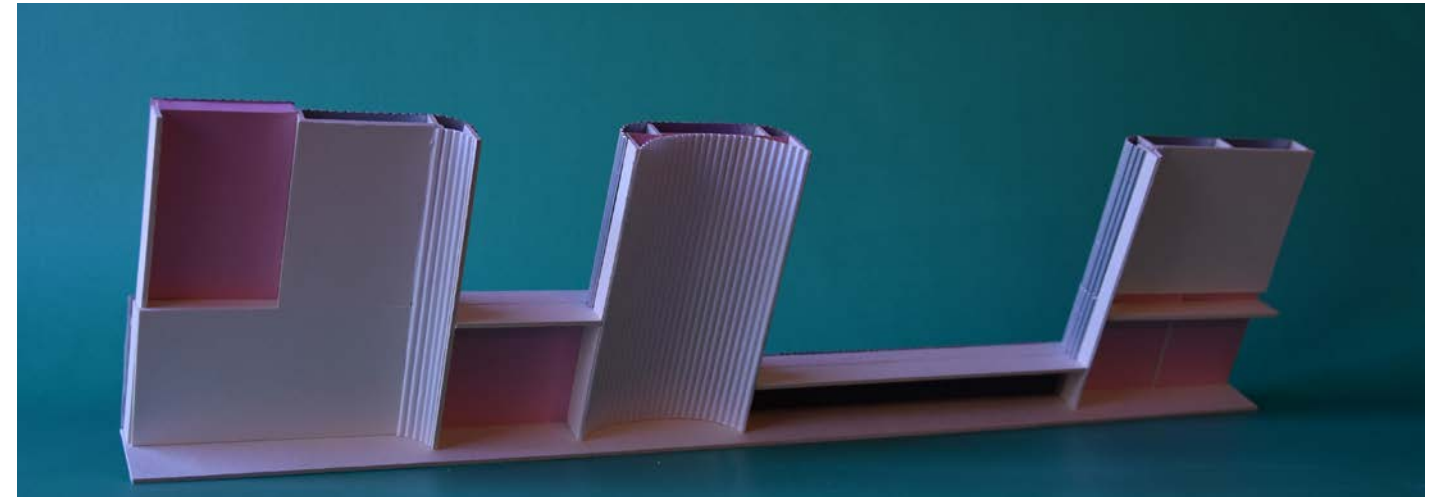
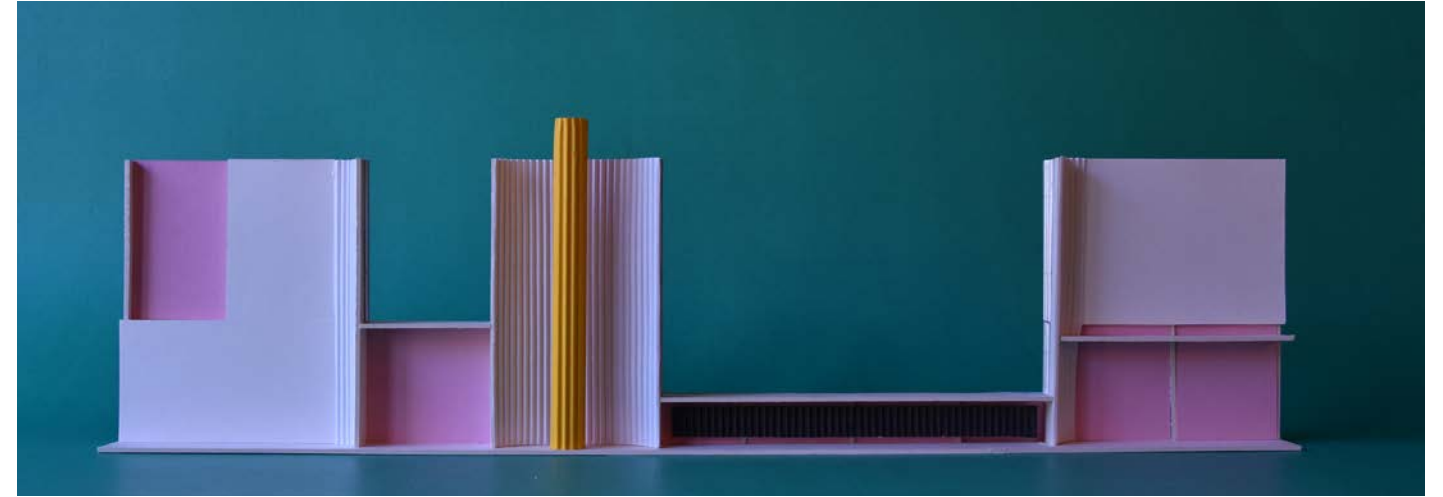
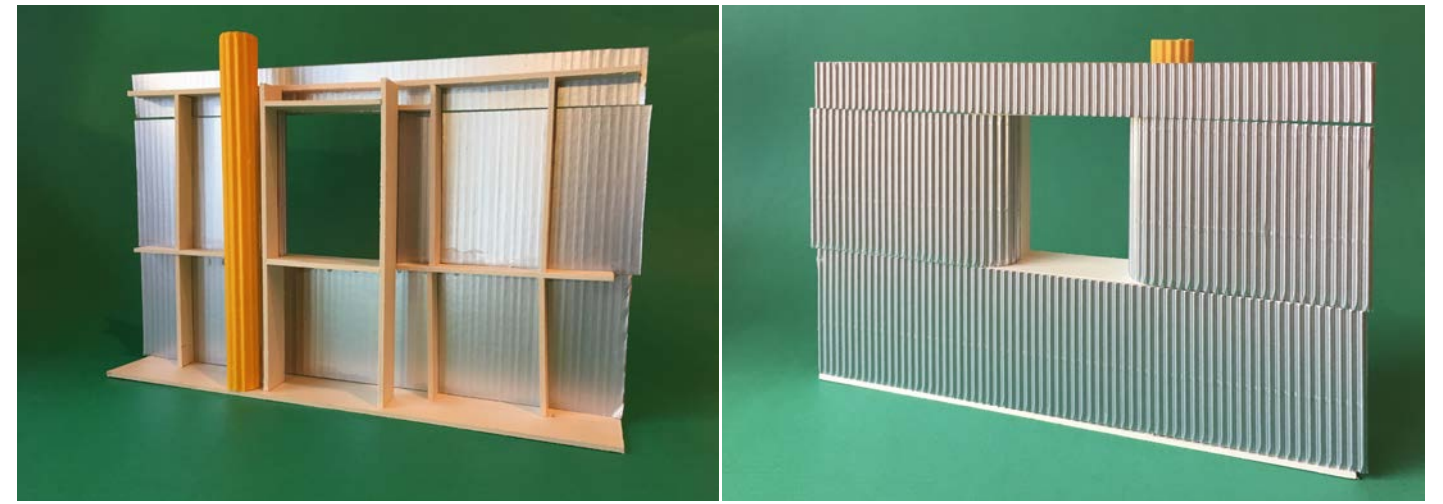
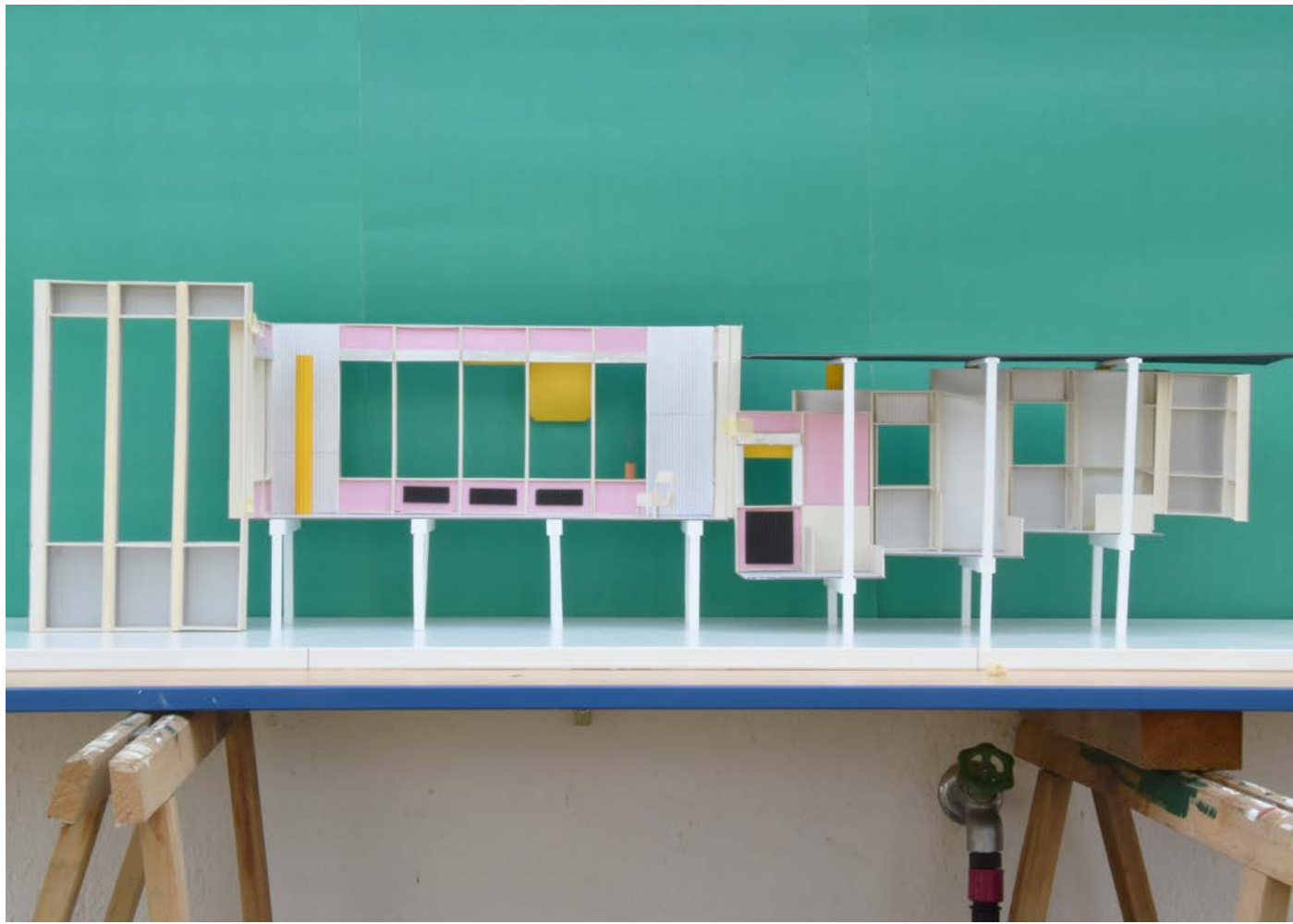

Chapter 0

0

universum carousel journey  
making meandering meaning - the studio

- 2 or 3 images of most representative drawings/images in one spread

Chapter 1

**Movement 1**

(group work, group presentation: 1 group / 3 students)  
Each group have studied each time 3 reference houses. Each time one of the other culture. And each time of another time or quality frame. As pointed out under 'making meandering meaning'.

- 3 images of 3 reference houses chosen by students
- one spread of wall movement 1
- series of images of models / drawings according to the narrative (could be 5-10 spread?)

Chapter 2

**Movement**

**2**

(individual work, individual presentation)  
Each group designed for each other house two neighbouring houses. Each student of each group took one of the neighbour houses as individual work. Each neighbouring house is a transcription of the reference houses studied in the first movement. The choice of cultural transcription is proposed by the students but each neighbouring situation should embrace all the different cultures.

- 2-3 images of most representative drawings/images in one spread  
(could be mix with M1 and M2)
- chapter of novel
- one spread image of overview of the presentation
- contextual axo drawing of the site
- series of images of models / drawings according to the narrative (could be 10-20 spread?)

Chapter 3

**Dialogue**

- contextual axo drawing of the neighboring projects of the colleagues all together

Archives

**A**

- series of small sketches/images/drawings that have not been shown

Epilogue