

universum carousel journey
re-practice prac-teach – a method
making meandering meaning – the studio
final review – spring 2020

Einhaus, Philip

Innocenti, Maria Margherita

Pitteloud, Stephanie

universum carousel journey – a studio
carousel journey universum – a practice
journey universum carousel – whatever
Studio Jan De Vylder
ETH Zürich D-ARCH IEA – FS 2020

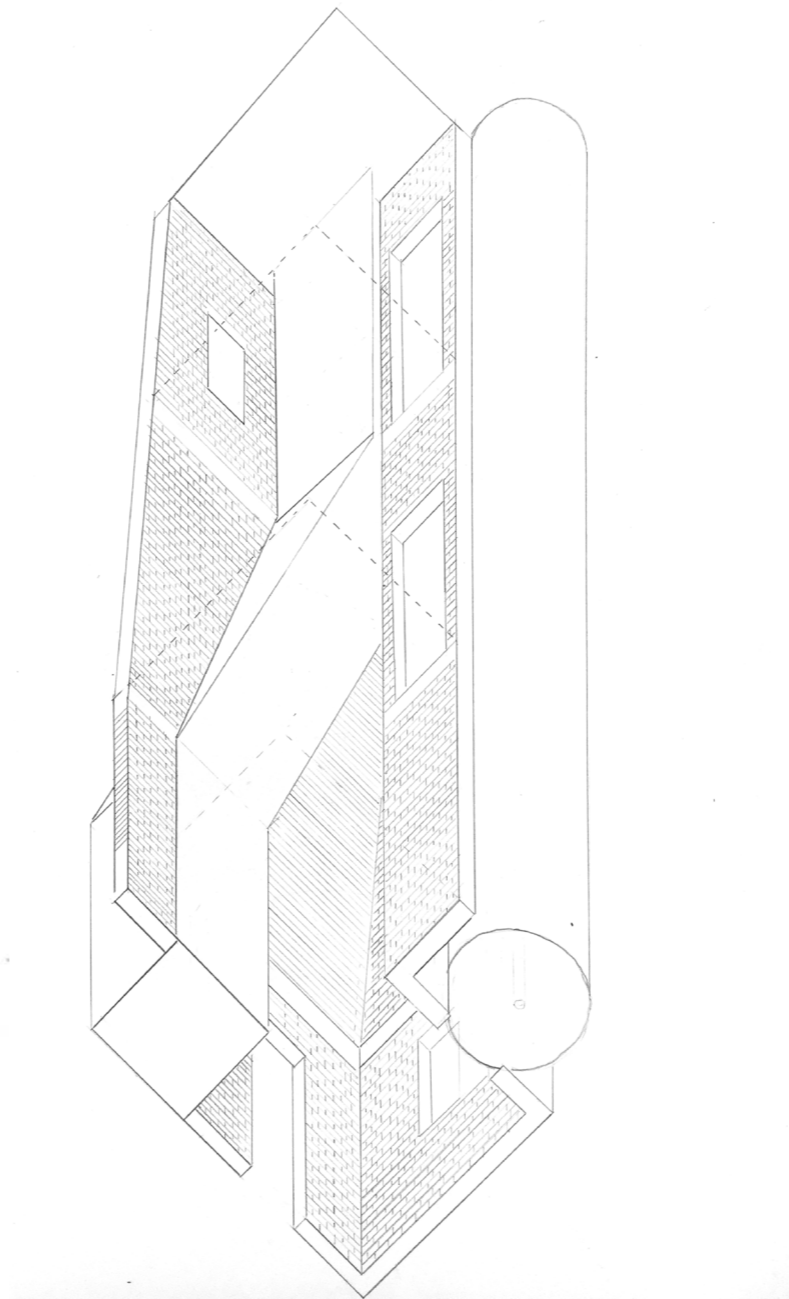

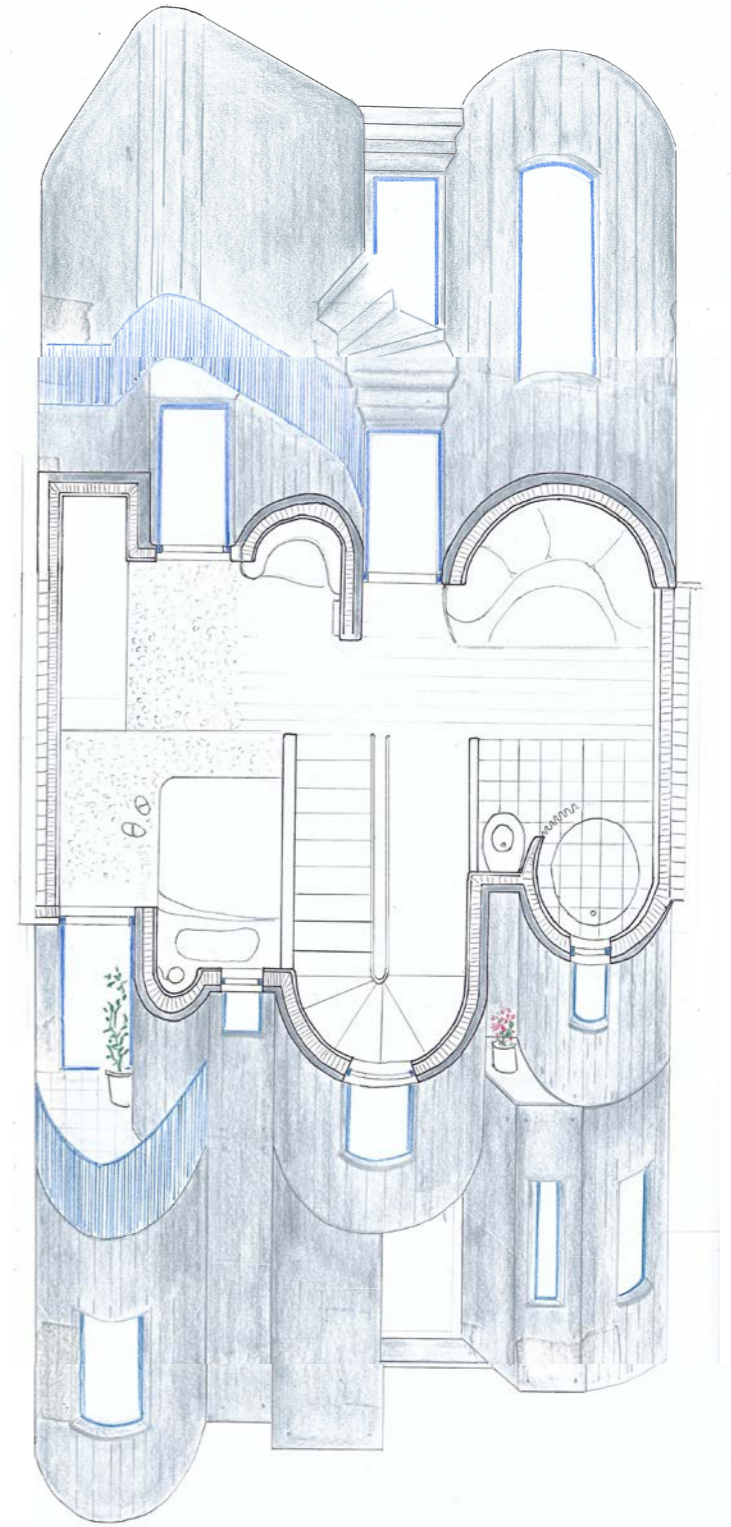
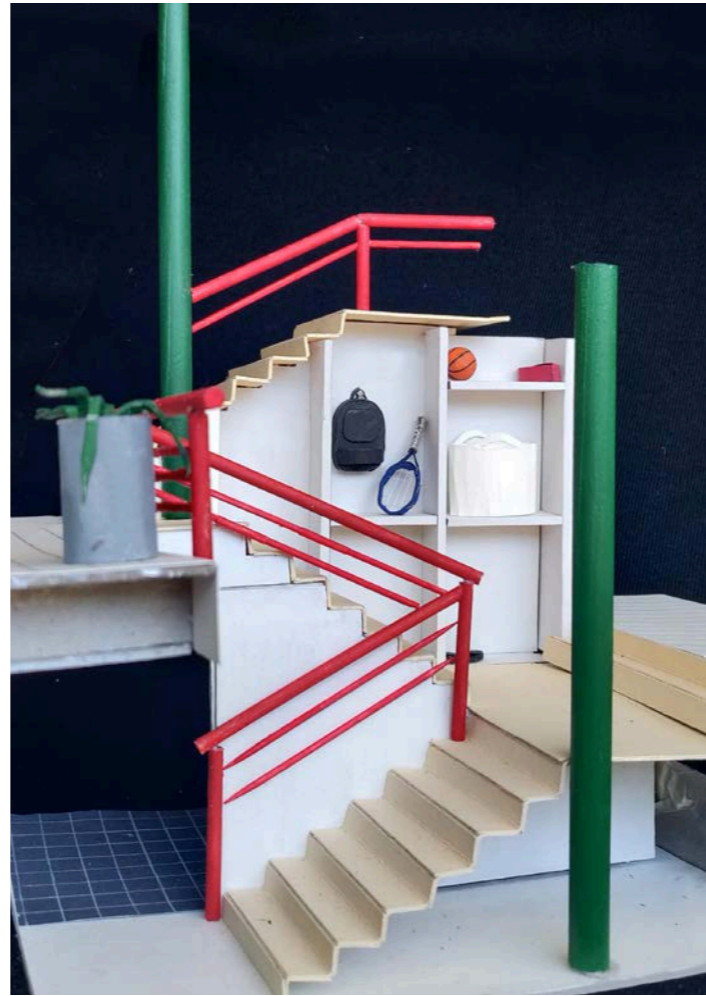
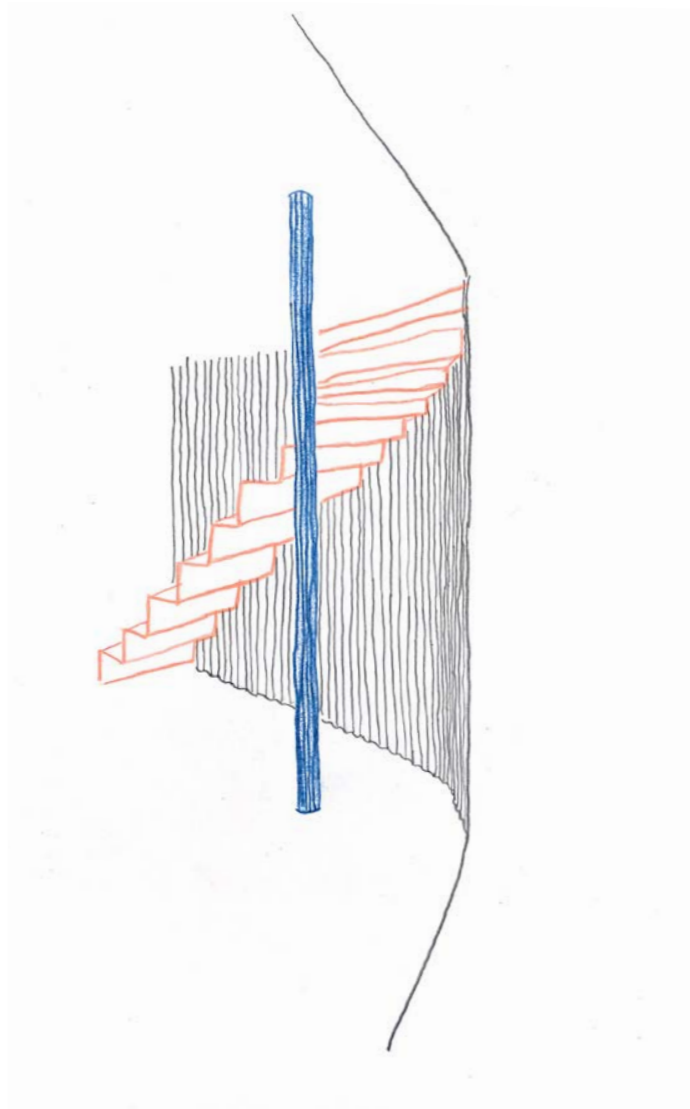

Movement 1

BE - Renè Magritte House

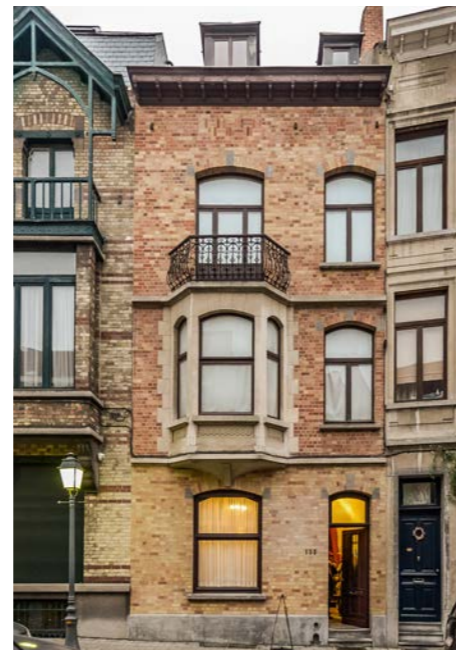

The hat

The street is empty, the day is
bright and the lamp is on.
I see him walking down the road
towards the front door.
Yellow, blue, green, then pink.
The easel is ready,
waiting in the corner.
He sits and starts painting.
Through the window he sees
the blue wall.
He draws the sky.
The pink room, the orange one.
The chessboard on the table,
the apple in the room.
Coffee pot on the stove,
water running in the bathtub.
Between us a door.
A room.
A staircase.
A chimney.
A coat hanger.
A hat.

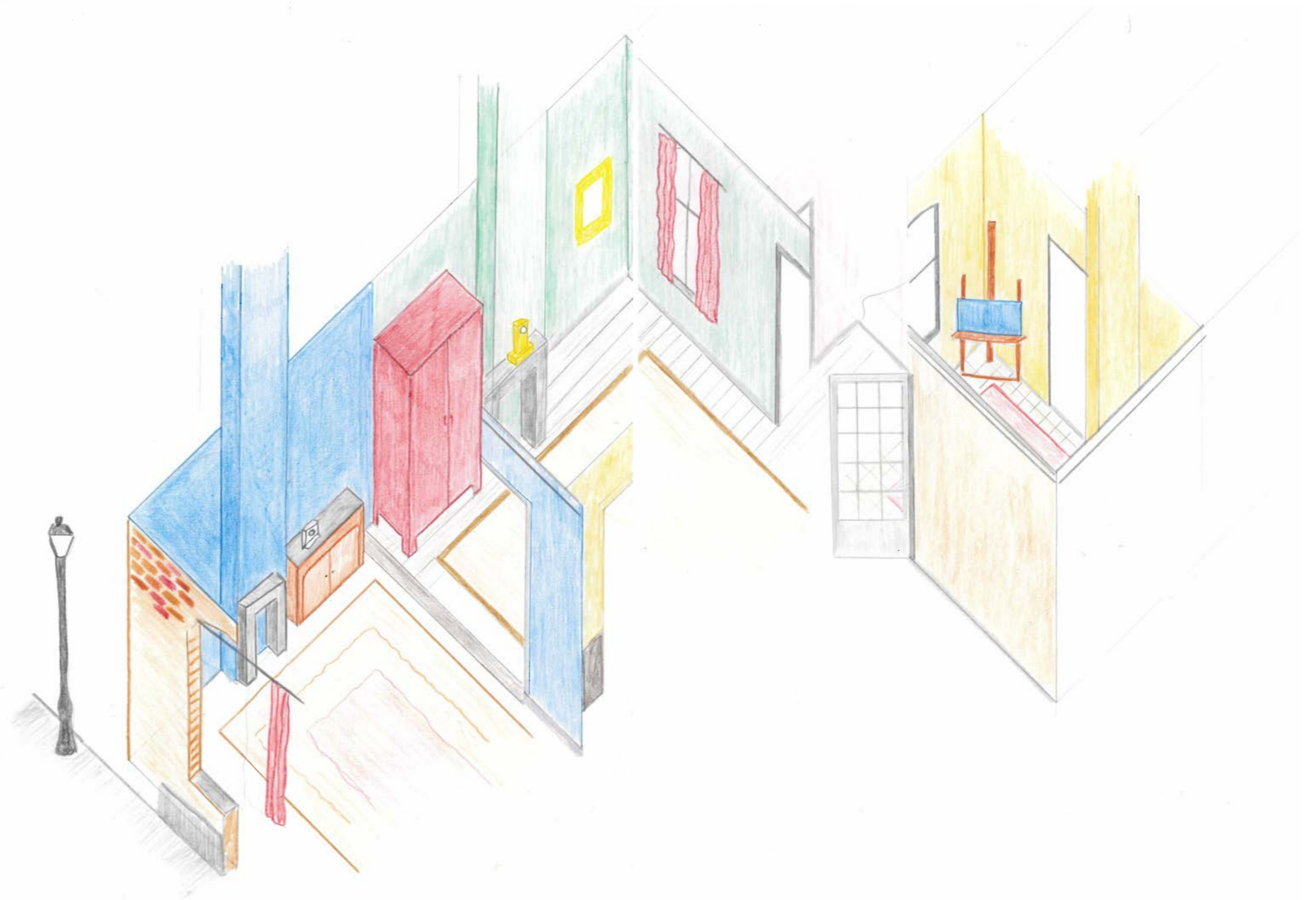

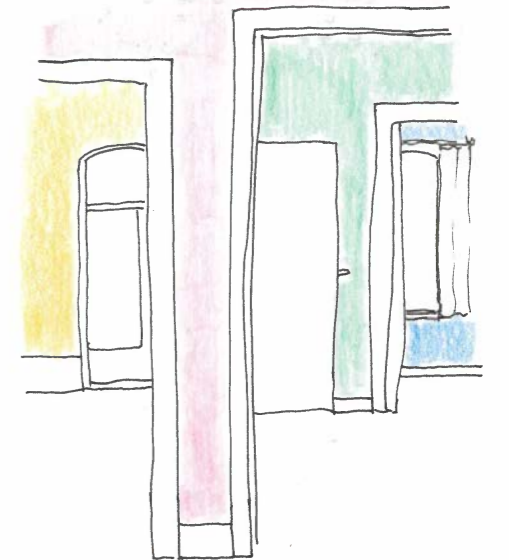
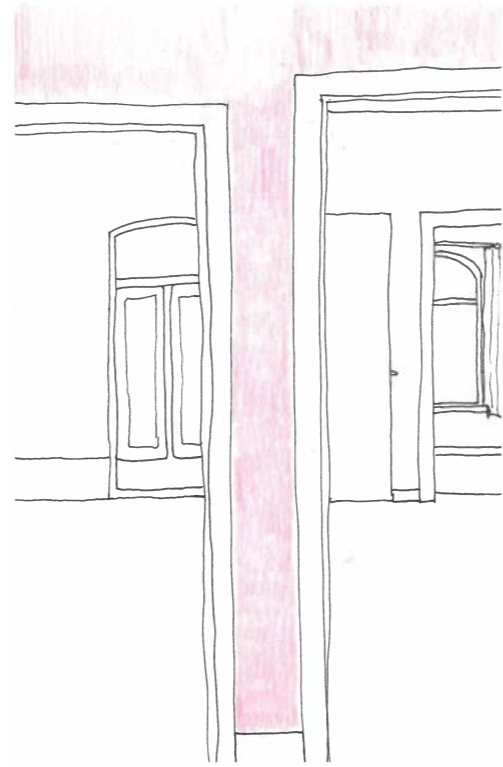

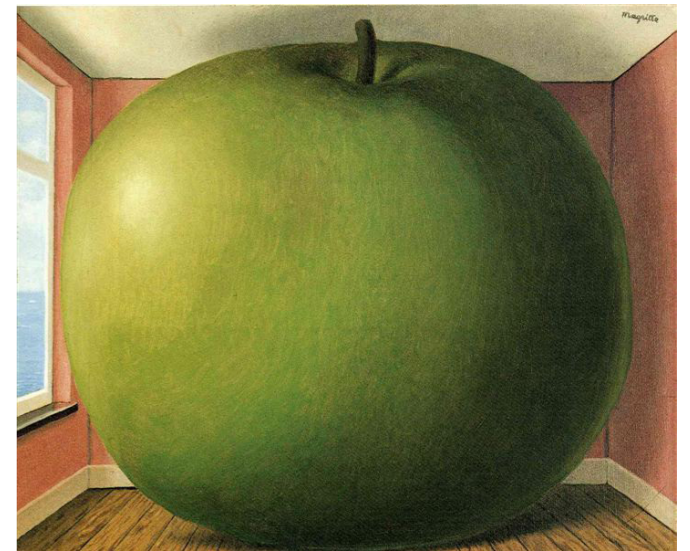
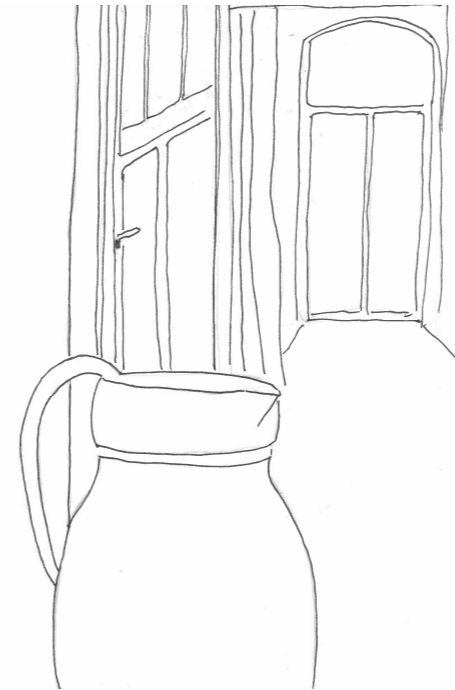
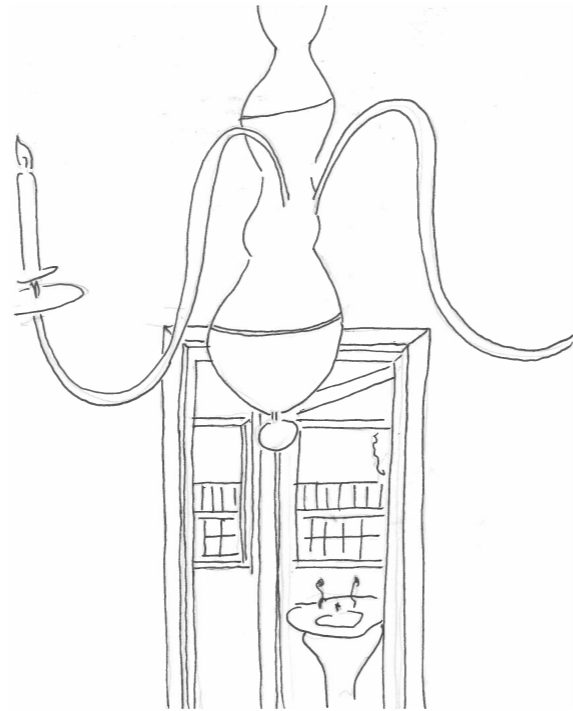
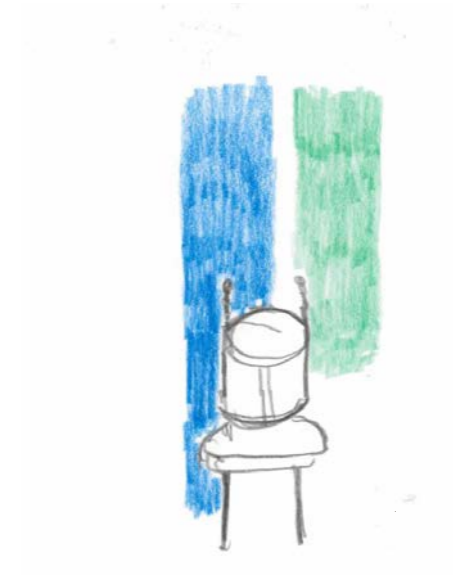
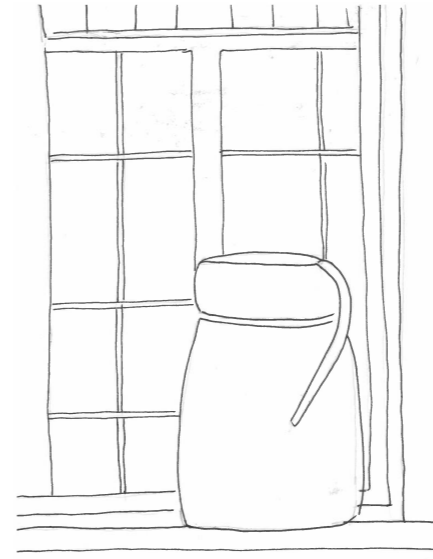
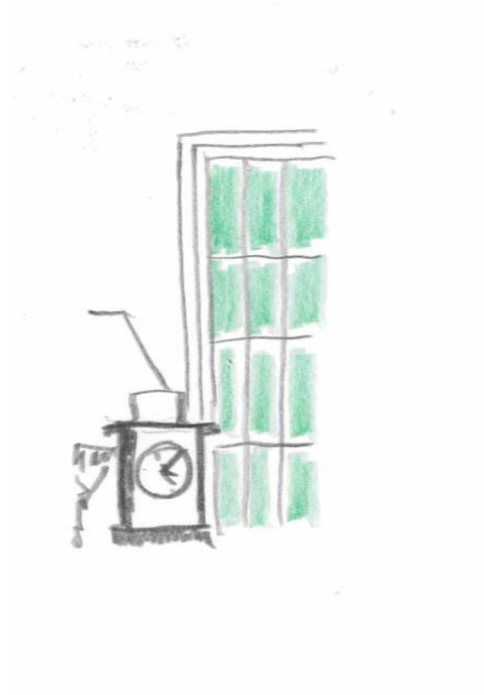

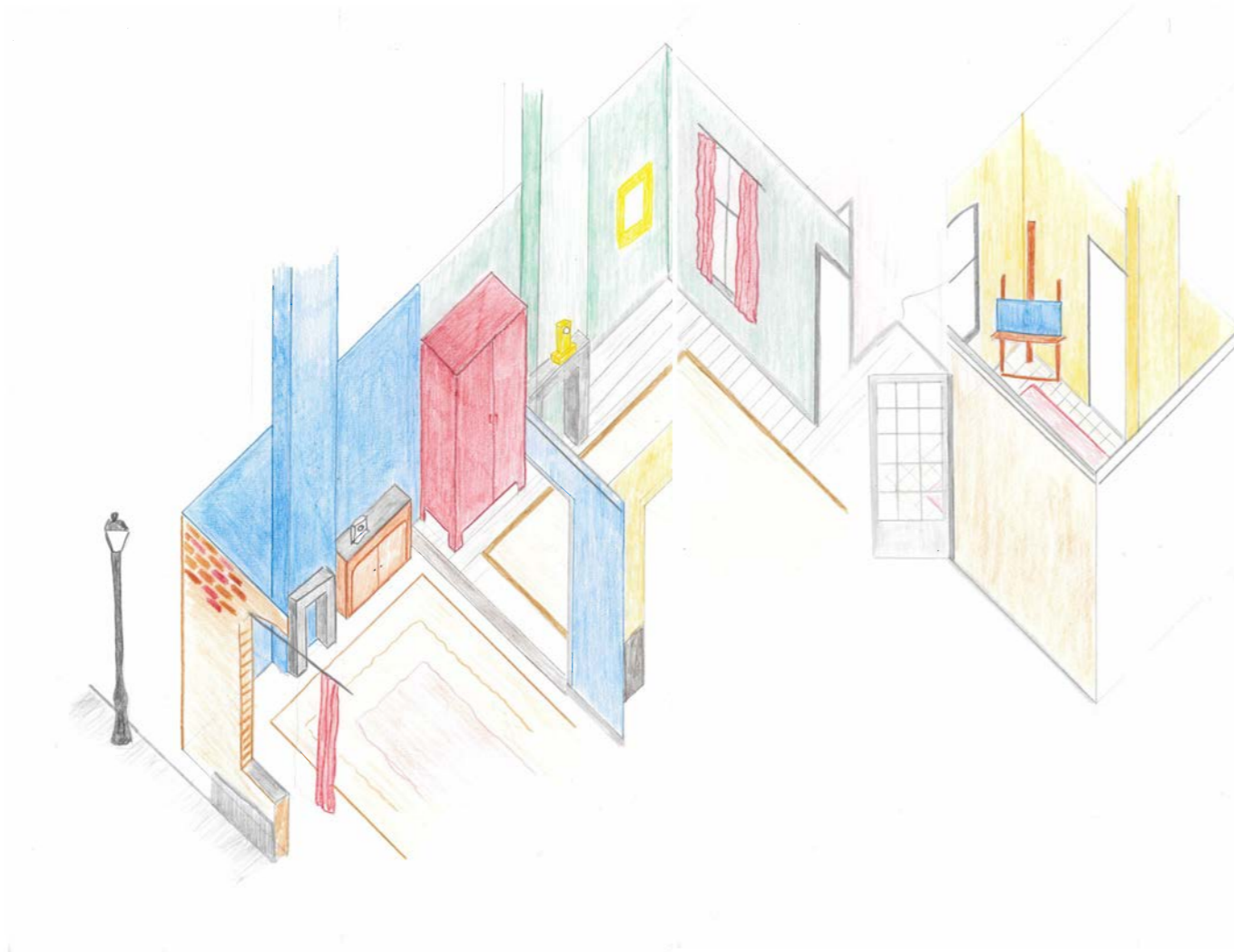

Movement 1

CH - Binningen II



The cat

I used to have a different shape, a simple one.

The others wouldn't even recognize me as one of them. Then they subtracted, added, shifted, deformed. Despite my many faces, I blend in now, seemingly.

But the others talk, and I remain silent.

The others move and I stand still. As the canvas of the sky resembles the canvas of my fur. While music resonates within the walls, and as a ball rolls down my feet.

As the swaying trees reflect in my eyes, while the sound of the dripping summer rain in the silver water pipe puts me to sleep.

Only to be awakened again by the metallic sound of the raising blinds letting through a warm ray of sunlight.

As people hover around me faster and faster
so fast that I don't know where I am anymore.

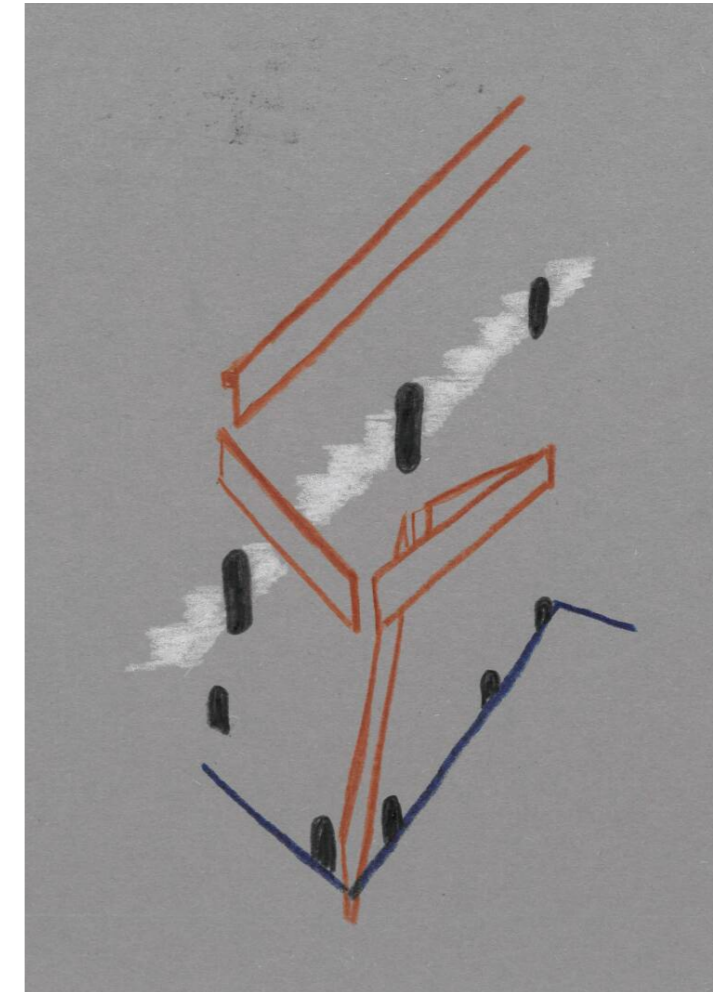

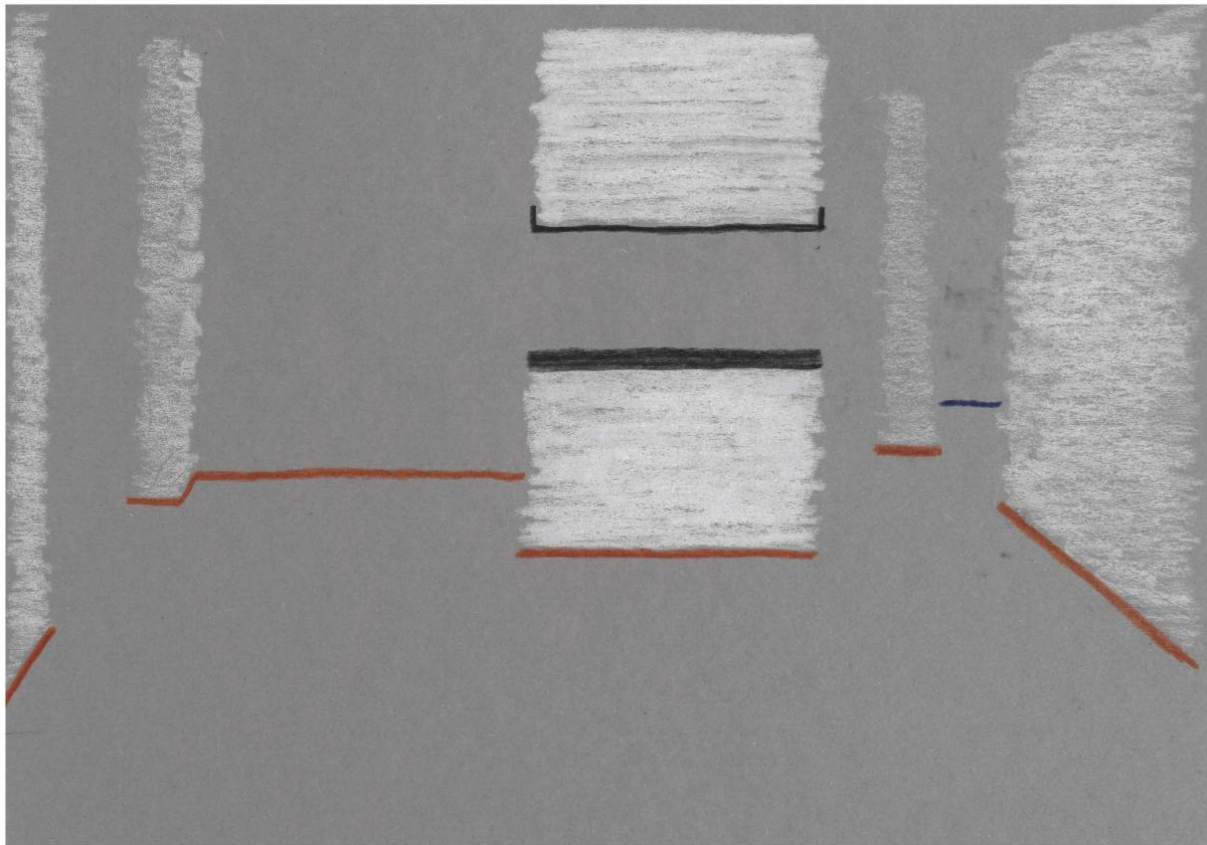

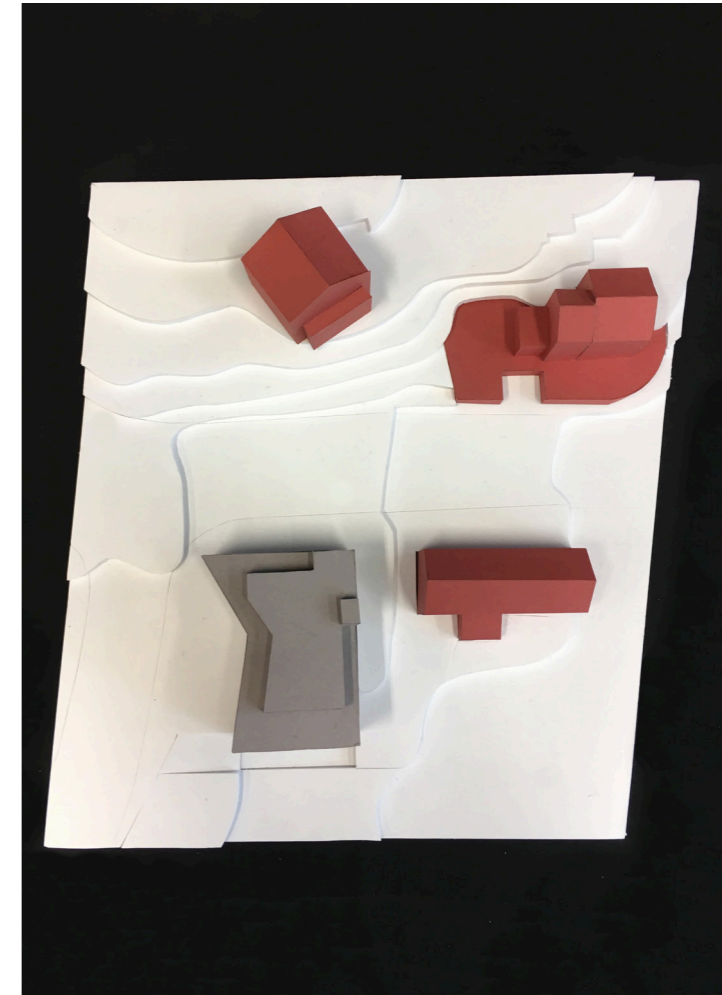
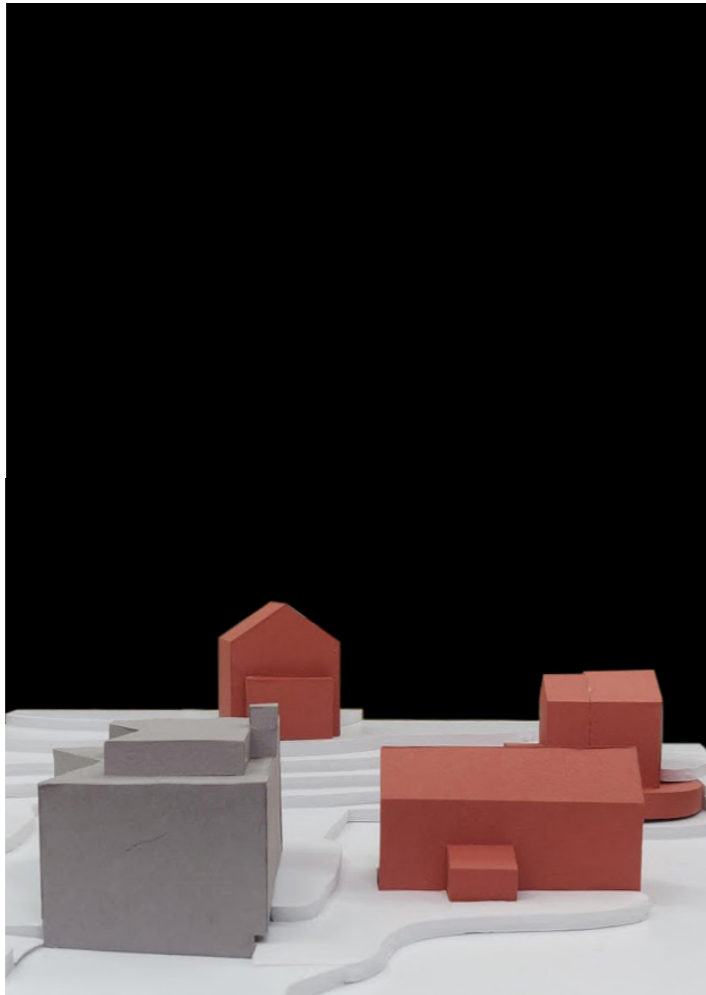

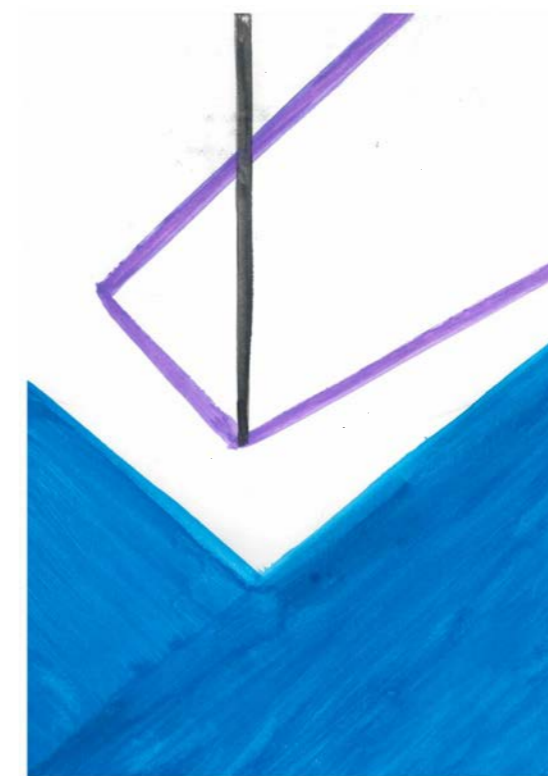
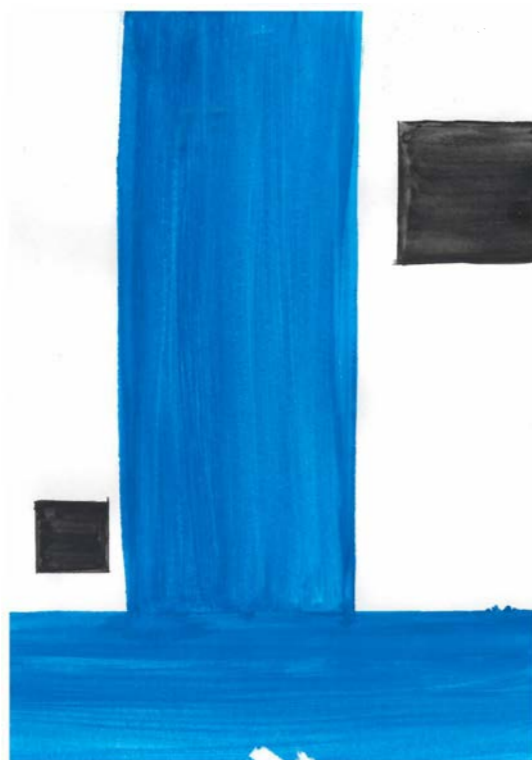
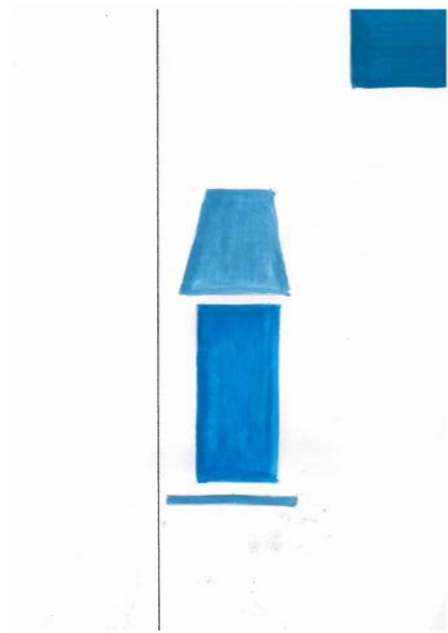

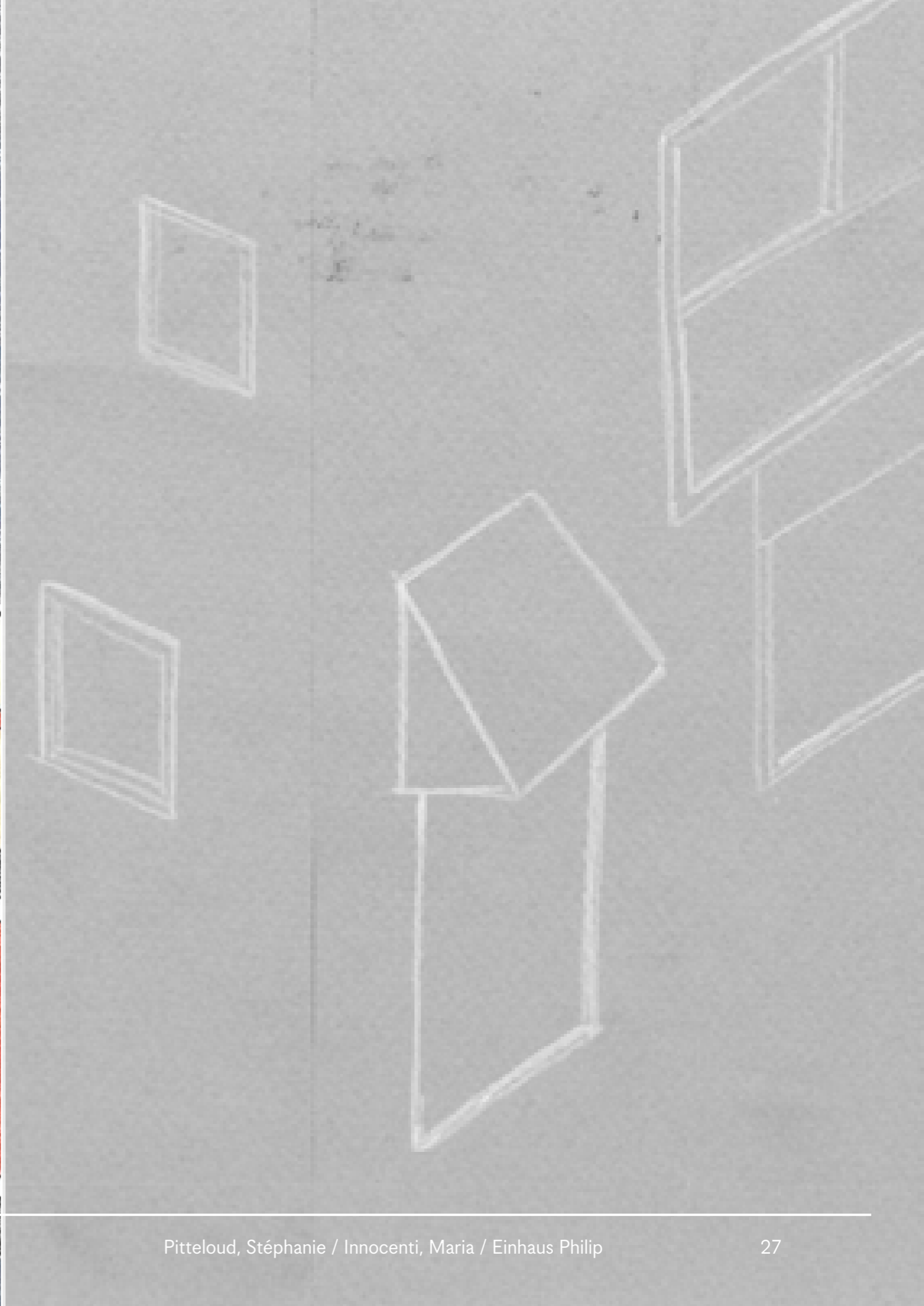
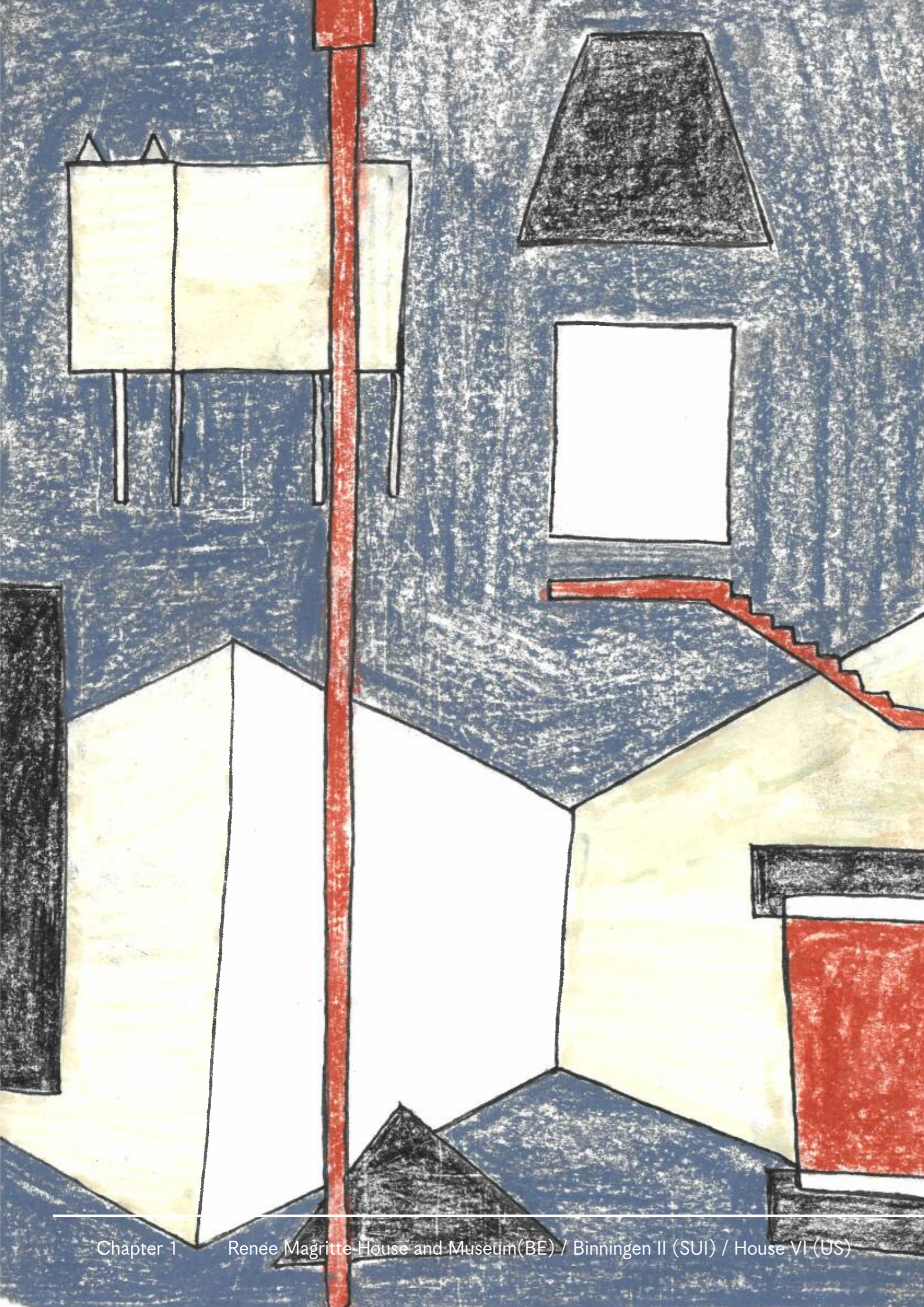

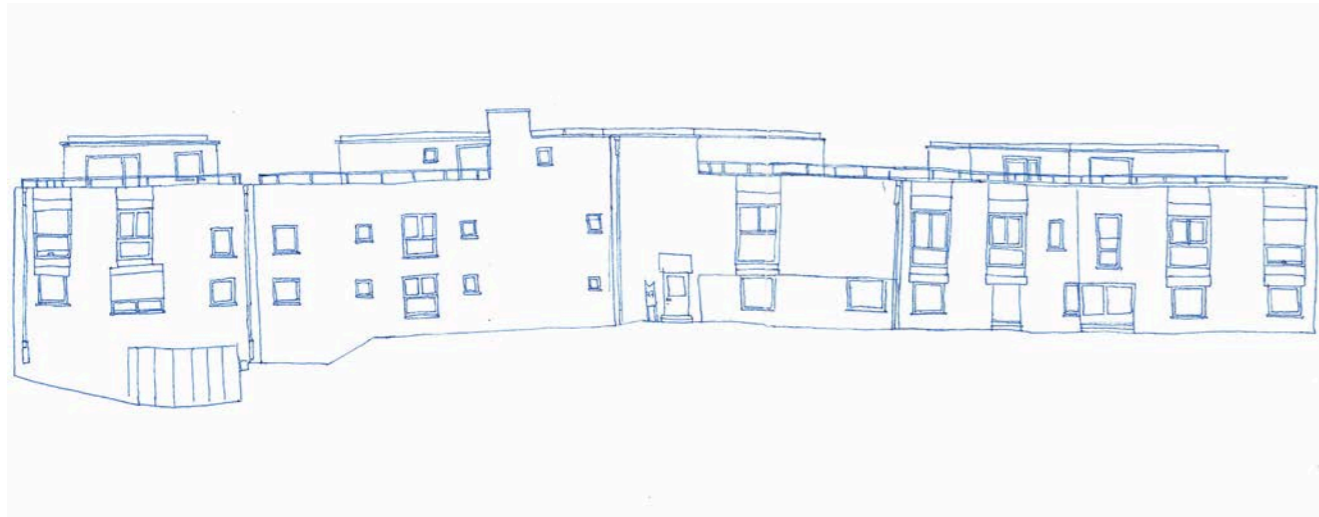

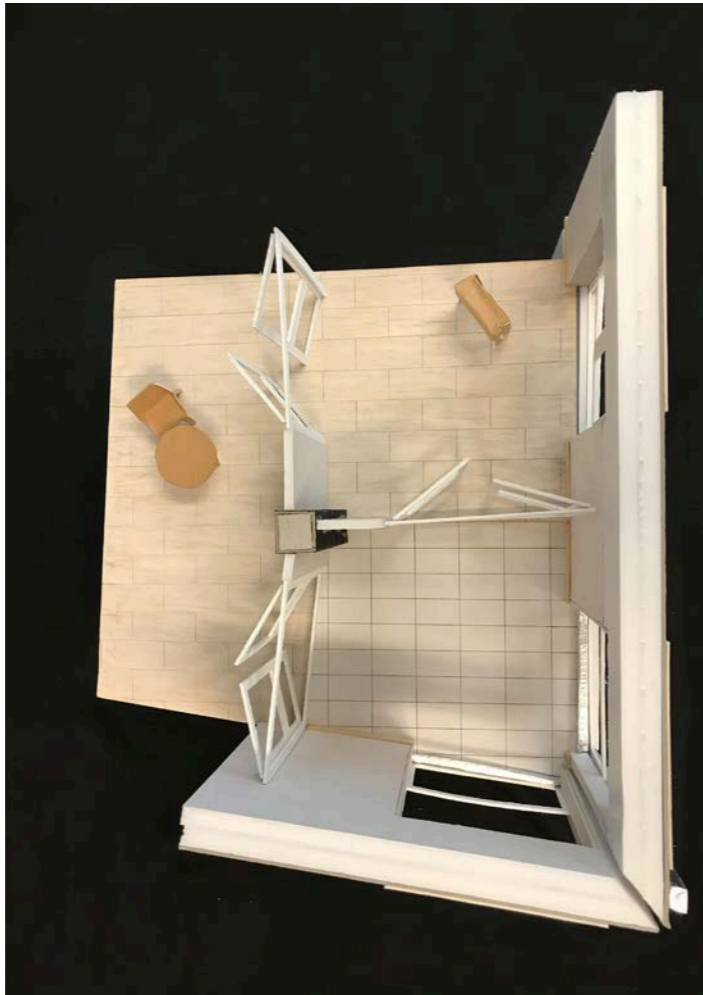

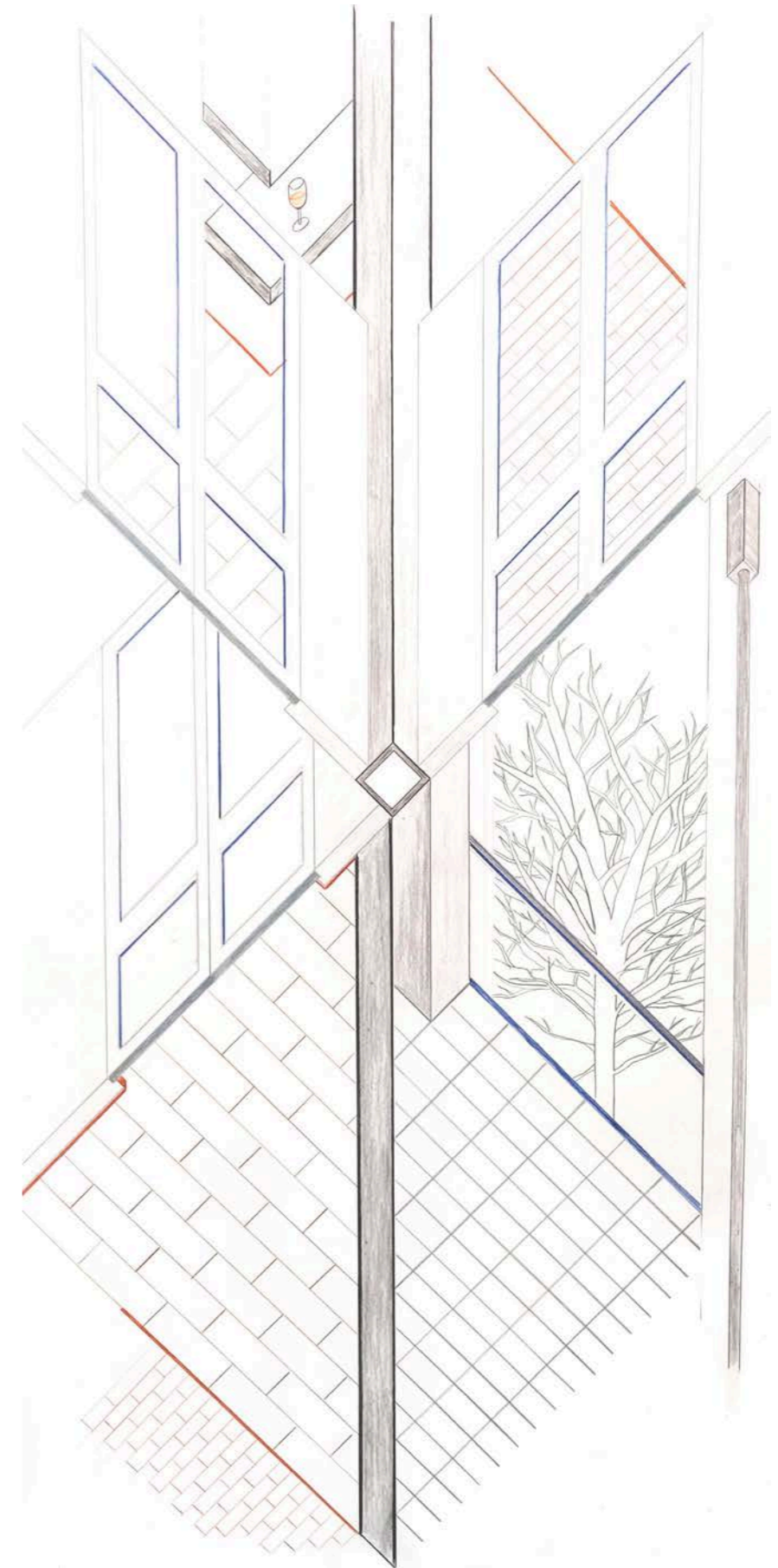
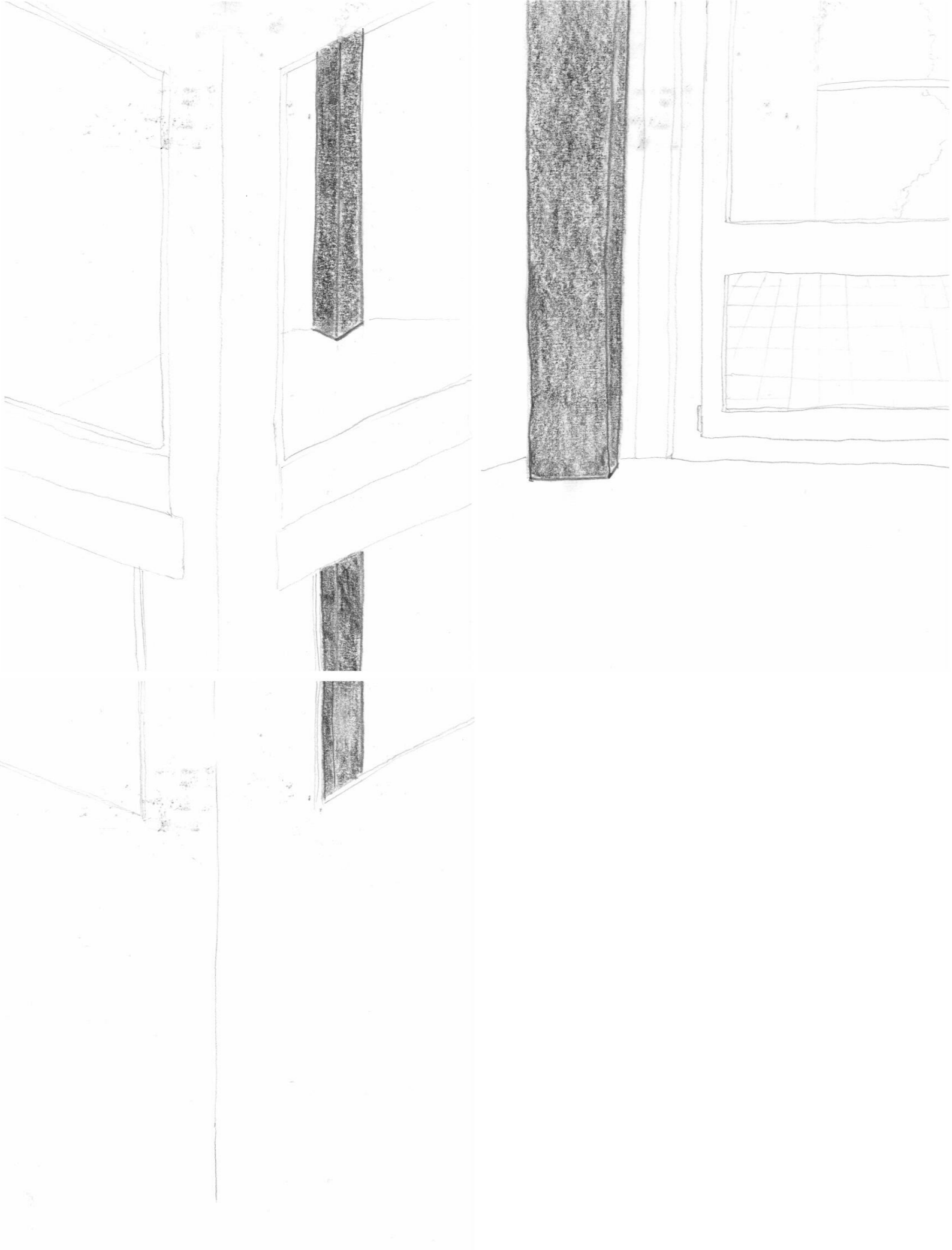

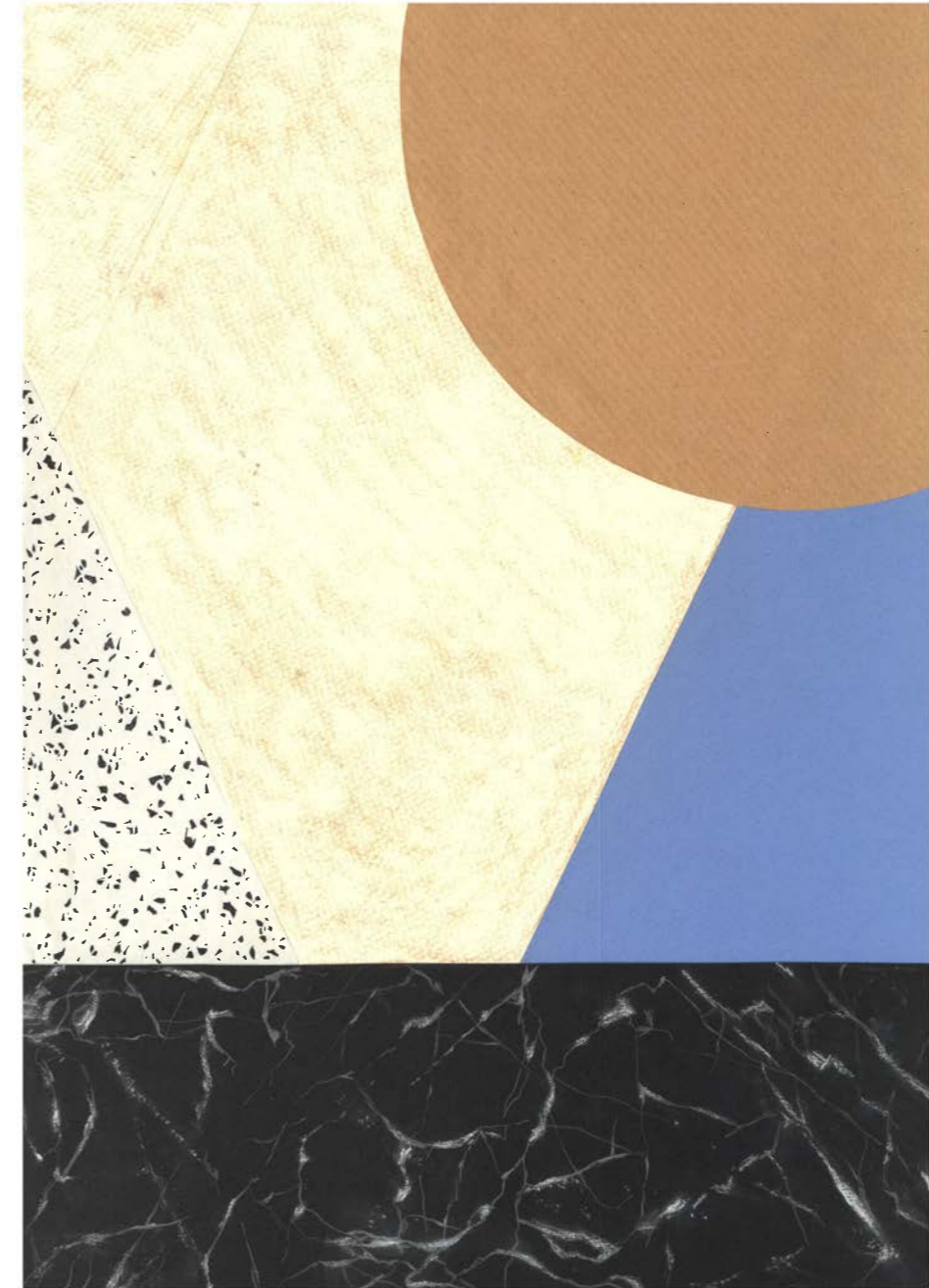

Movement 1

US - House VI

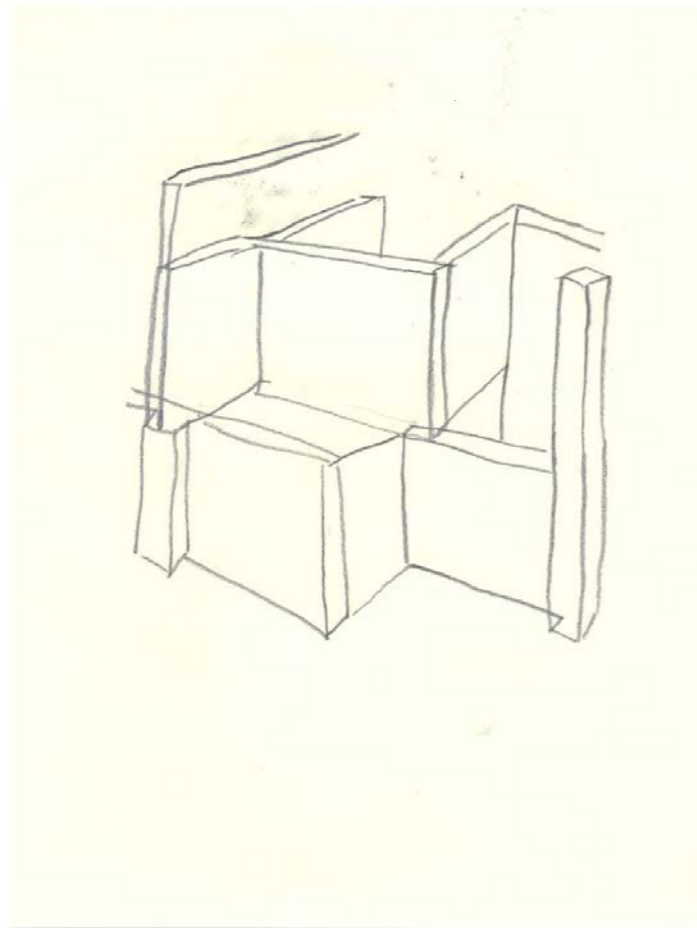

The house

As I arrive at the Rock, I see the house.
it is already dark outside, only the house
illuminates the trees around it.

I approach it, but i see no entrance,
I walk around it, twice, then i find it.
The slabs enclose me like a cave, but a
cave full of light.
This huge red staircase hovers above
the dining table as i approach my two
friends that are awaiting me.
As I take a seat, I realize, that two co-
lumns join our dinner. Instead of three,
we are five now, gathered around the
table.

I prepare my bed on the couch, lay
down and rest. I open my eyes , just to
see my friends trough a cut in the cei-
ling, getting ready for bed.
what a confusing night we had, the five
of us.



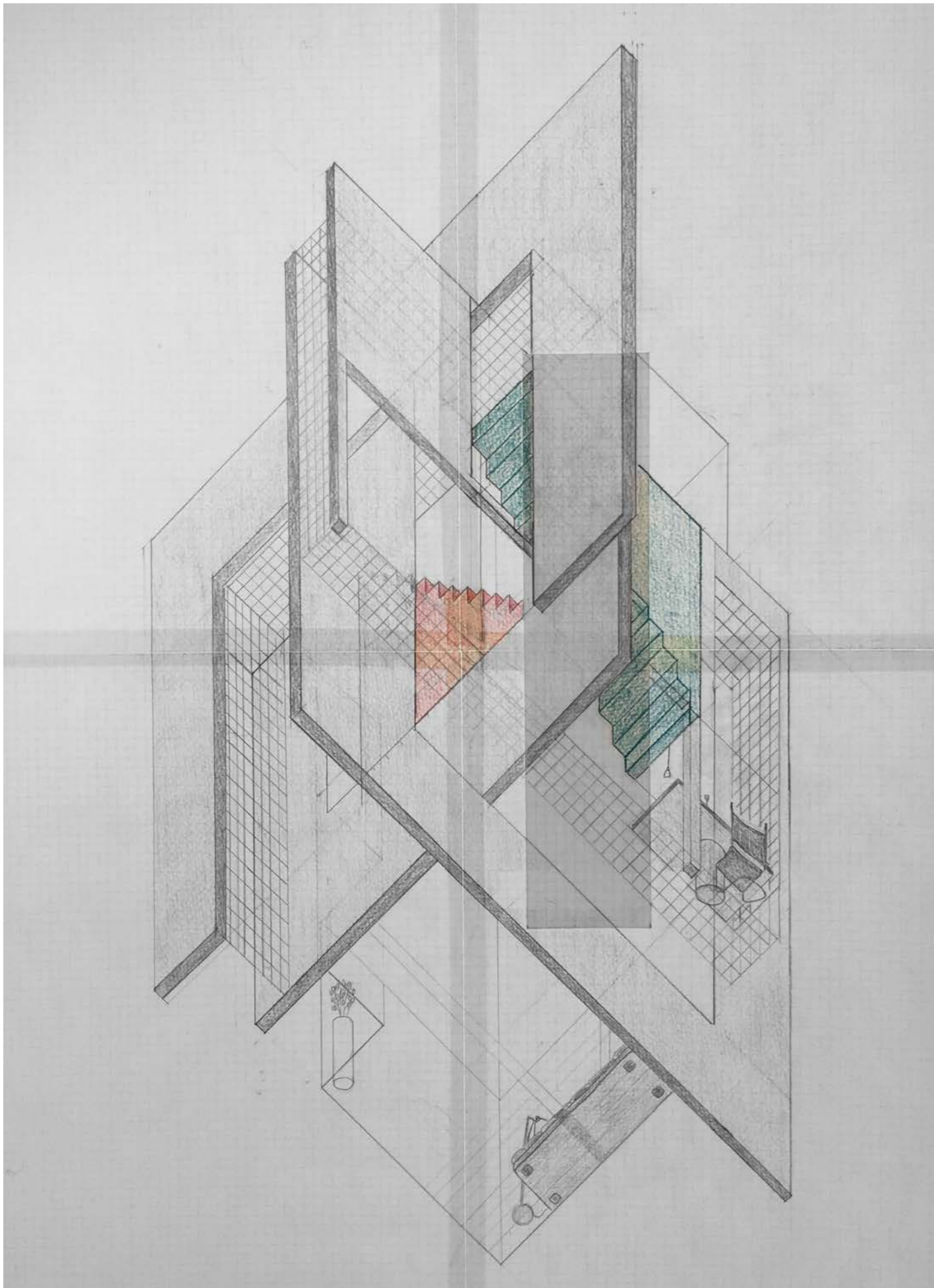

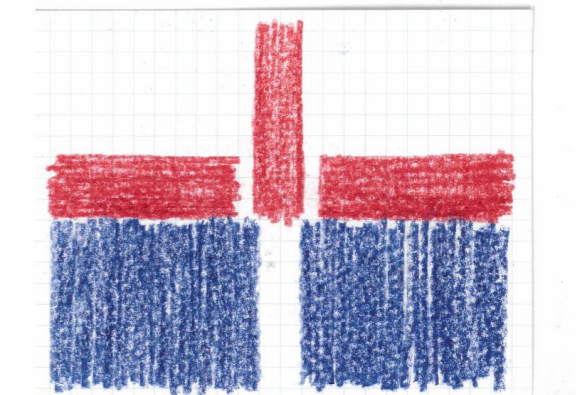
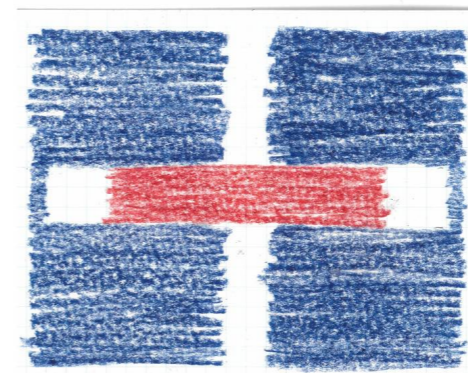
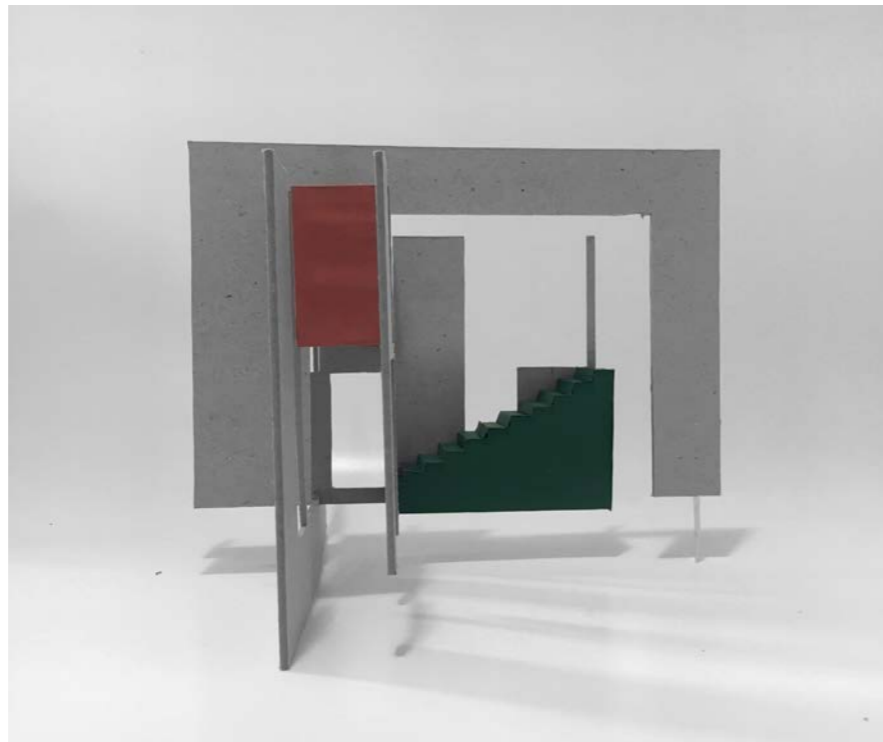
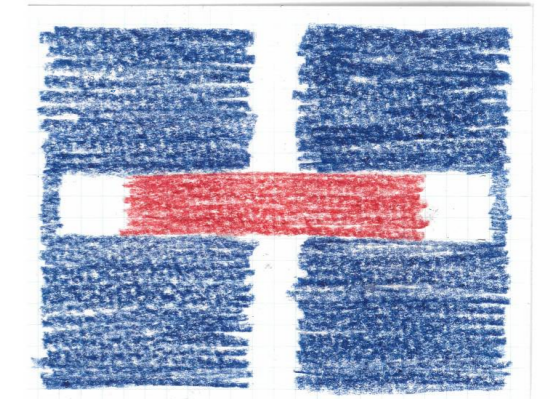
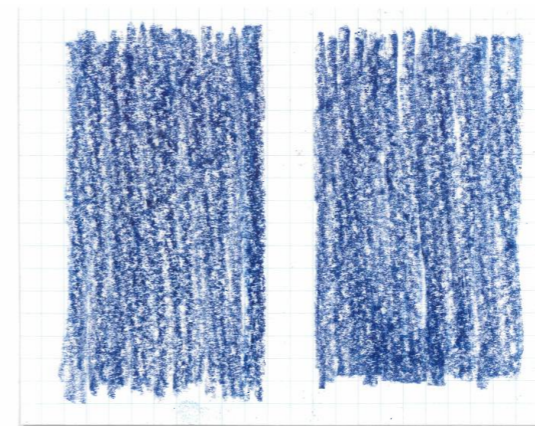
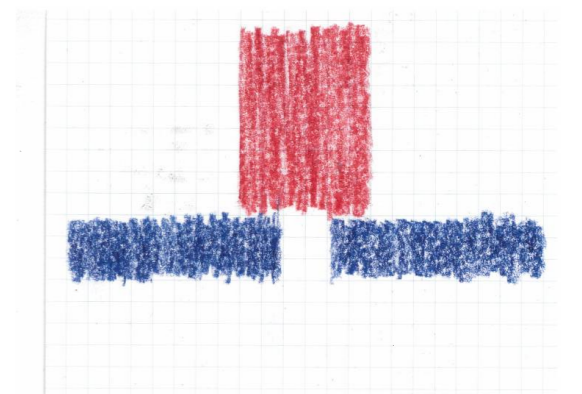
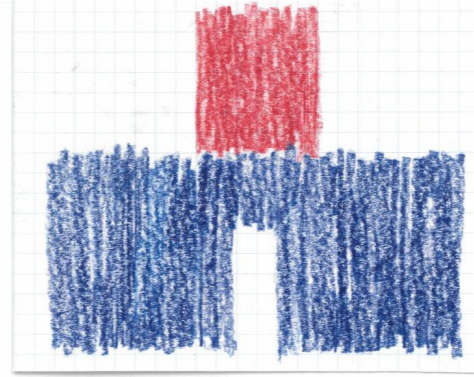
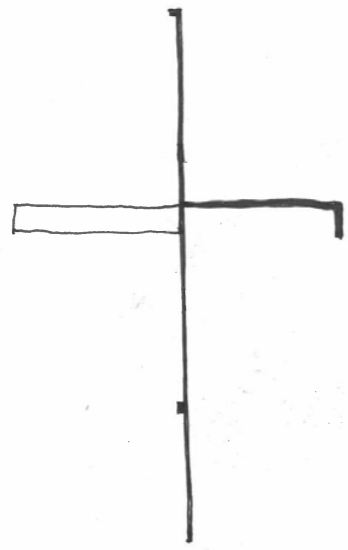

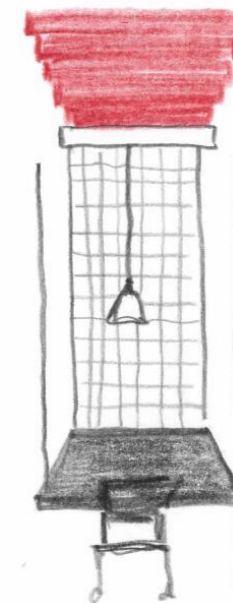
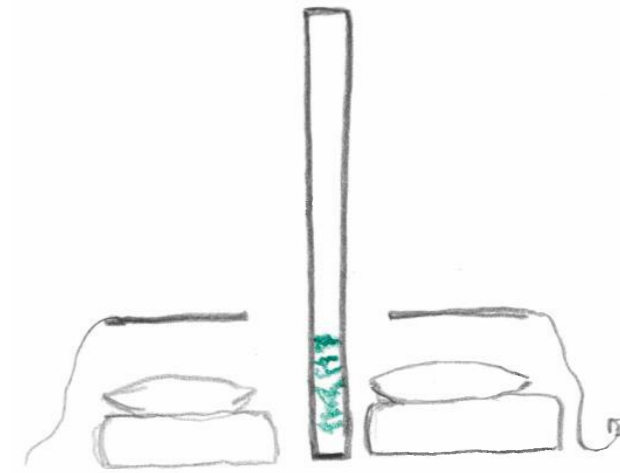
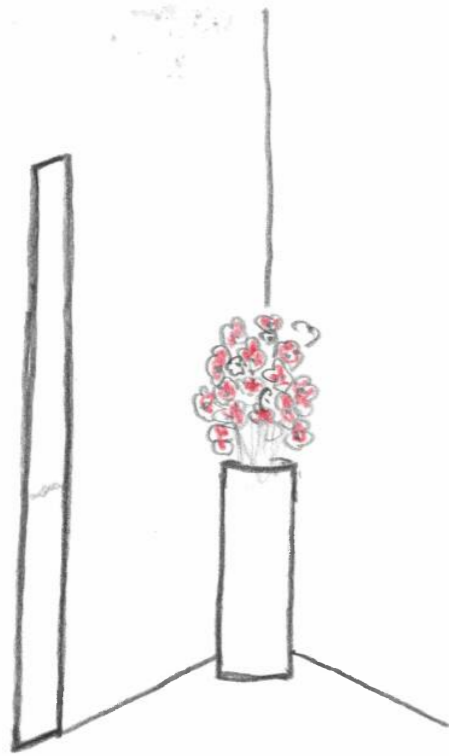

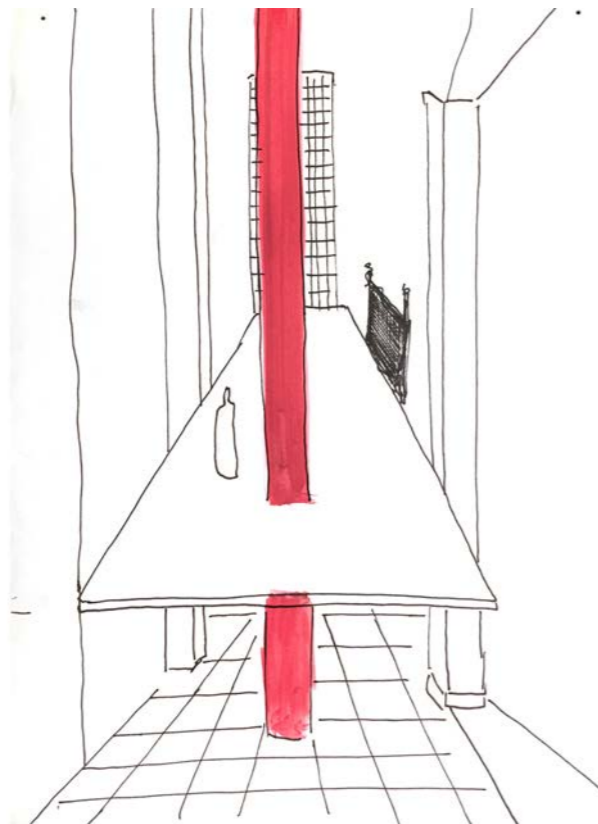

Movement 2

America

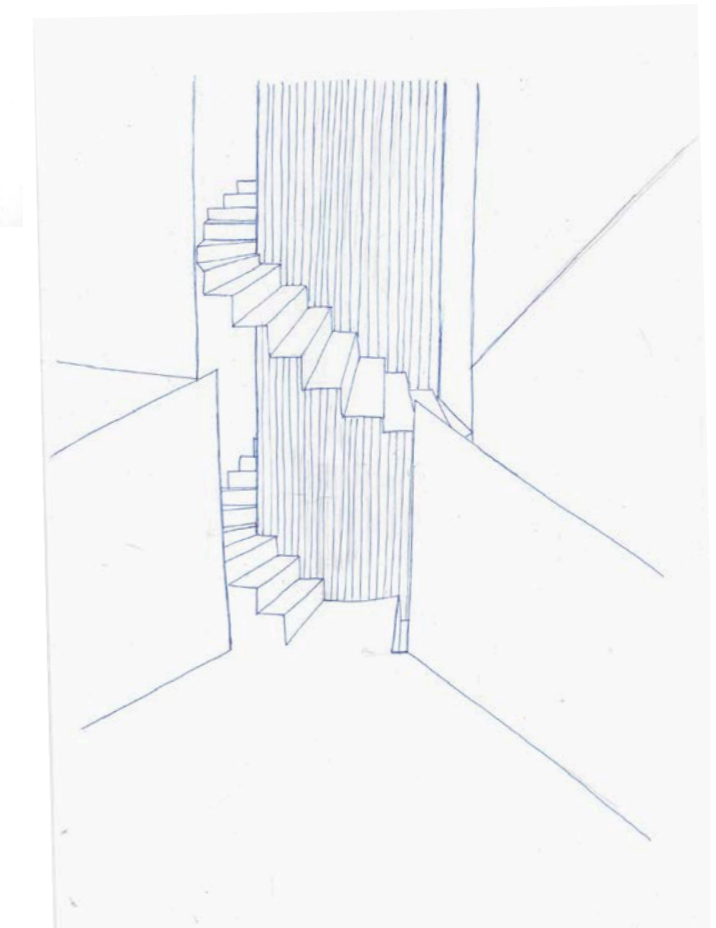
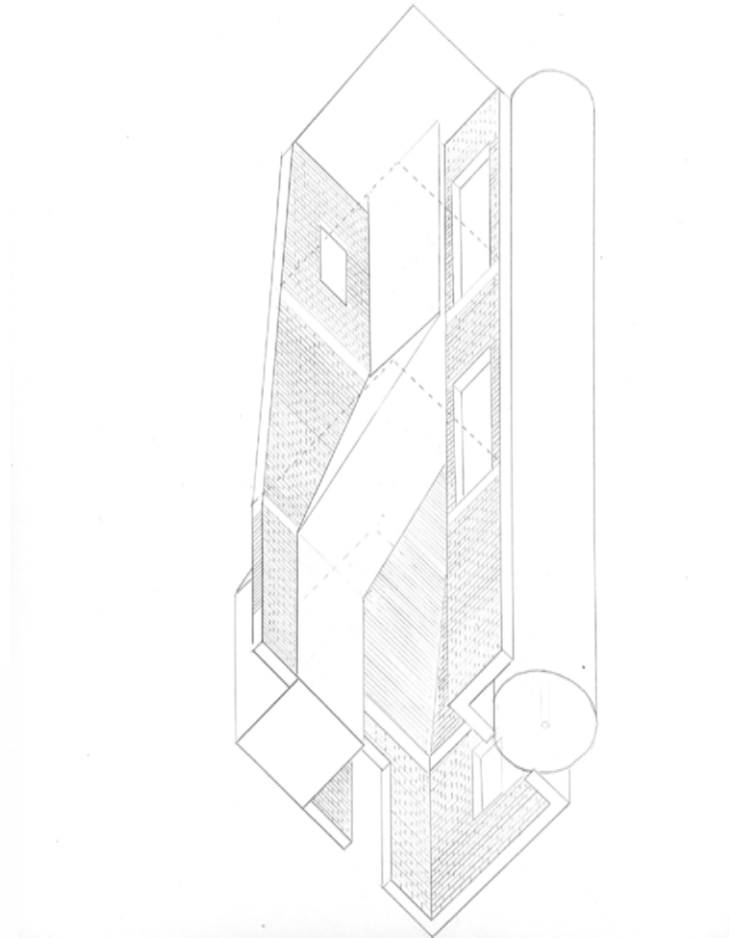
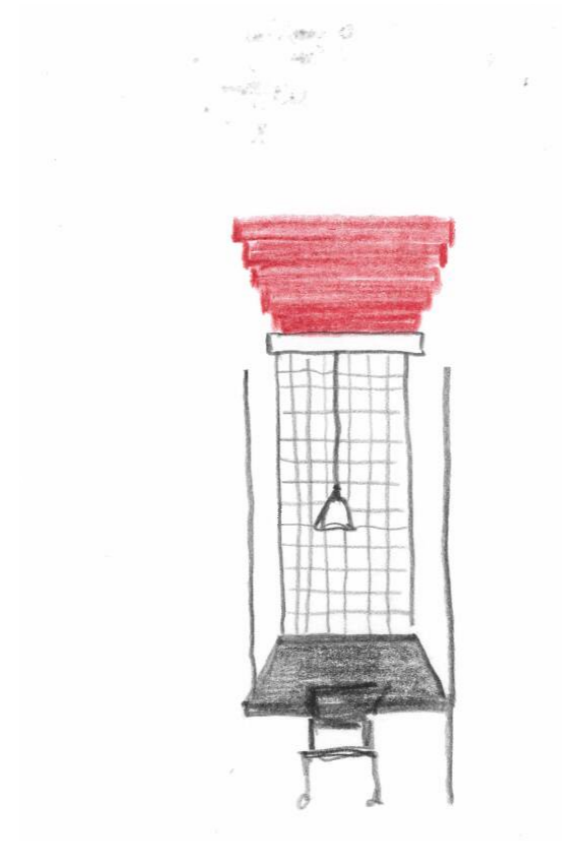

Movement 2

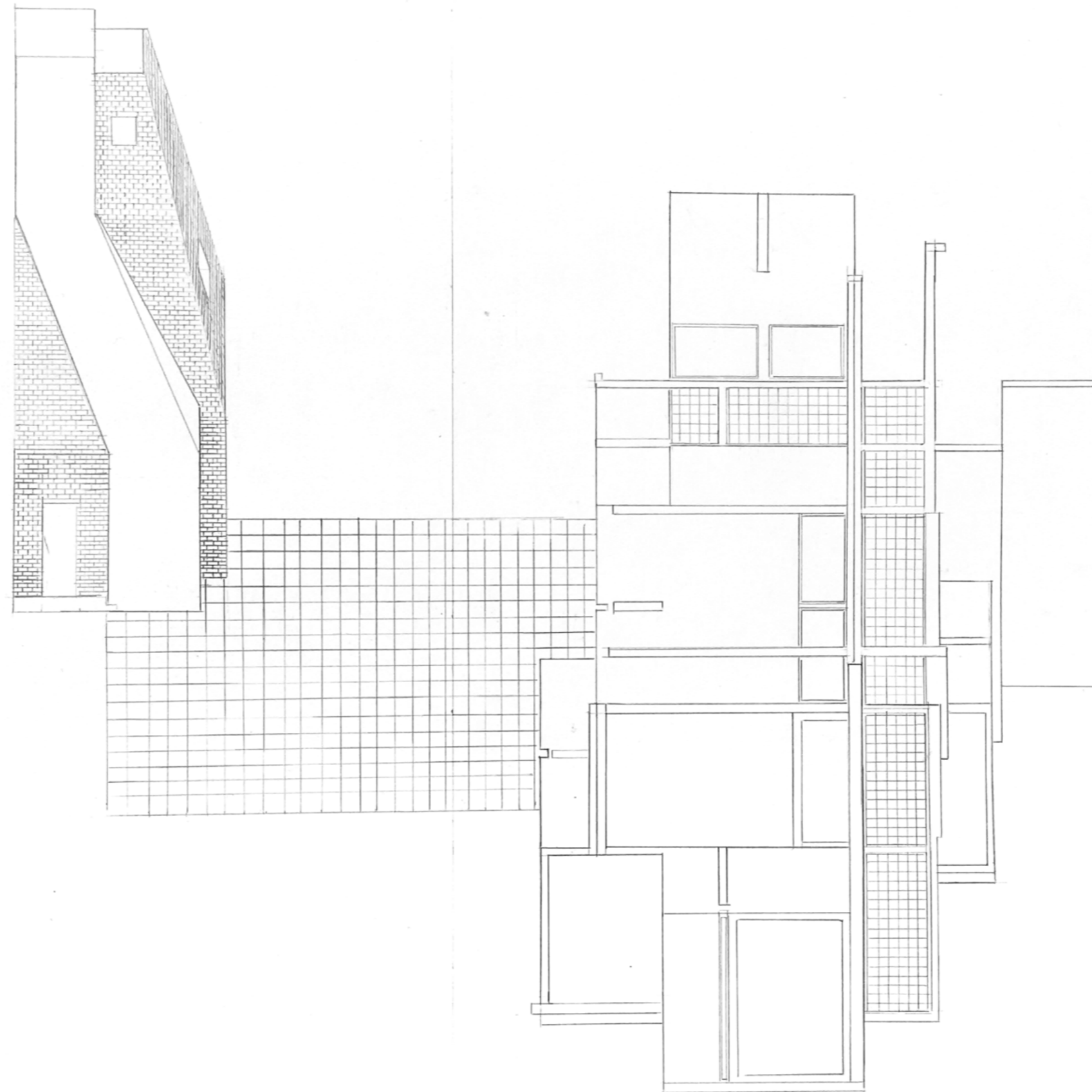

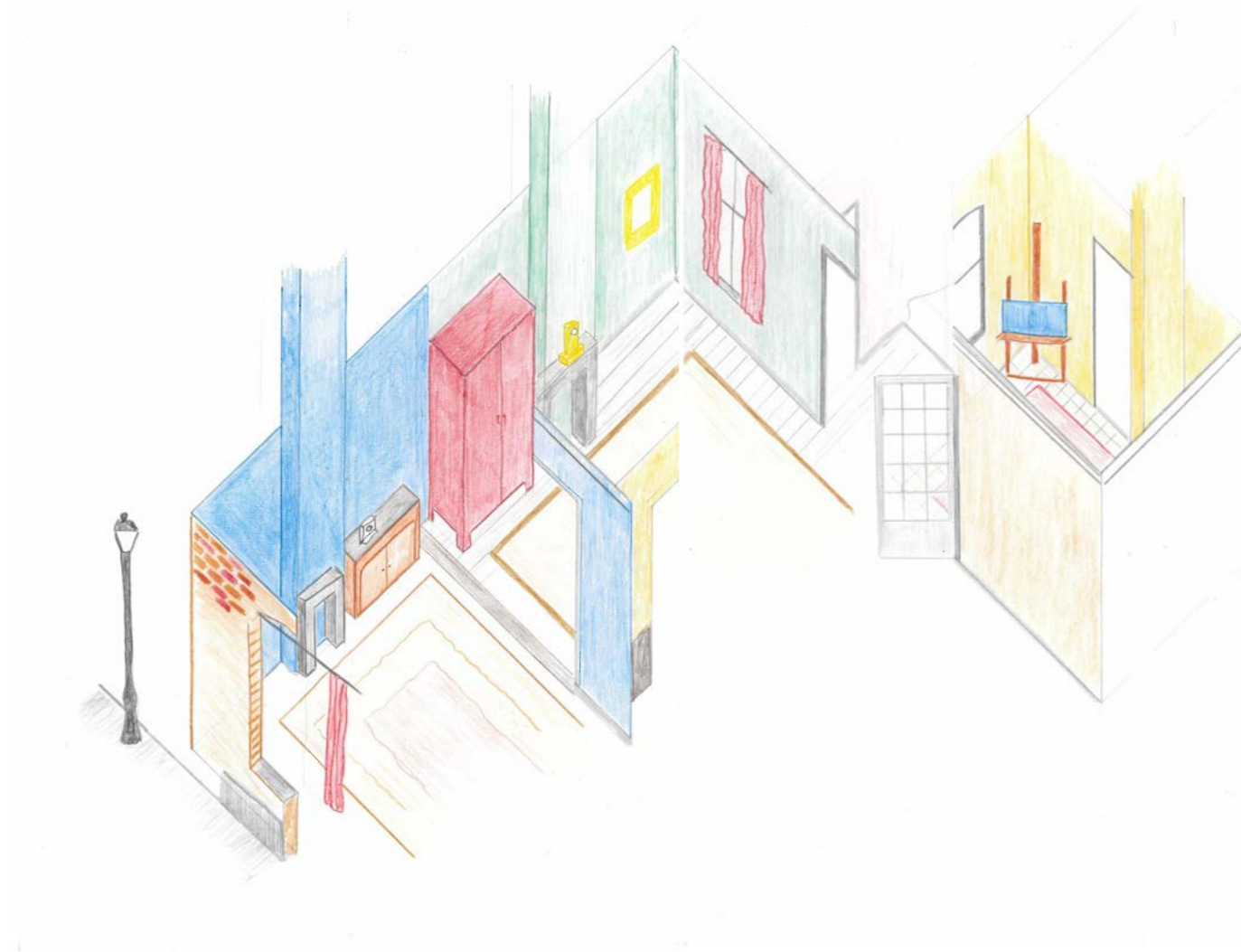

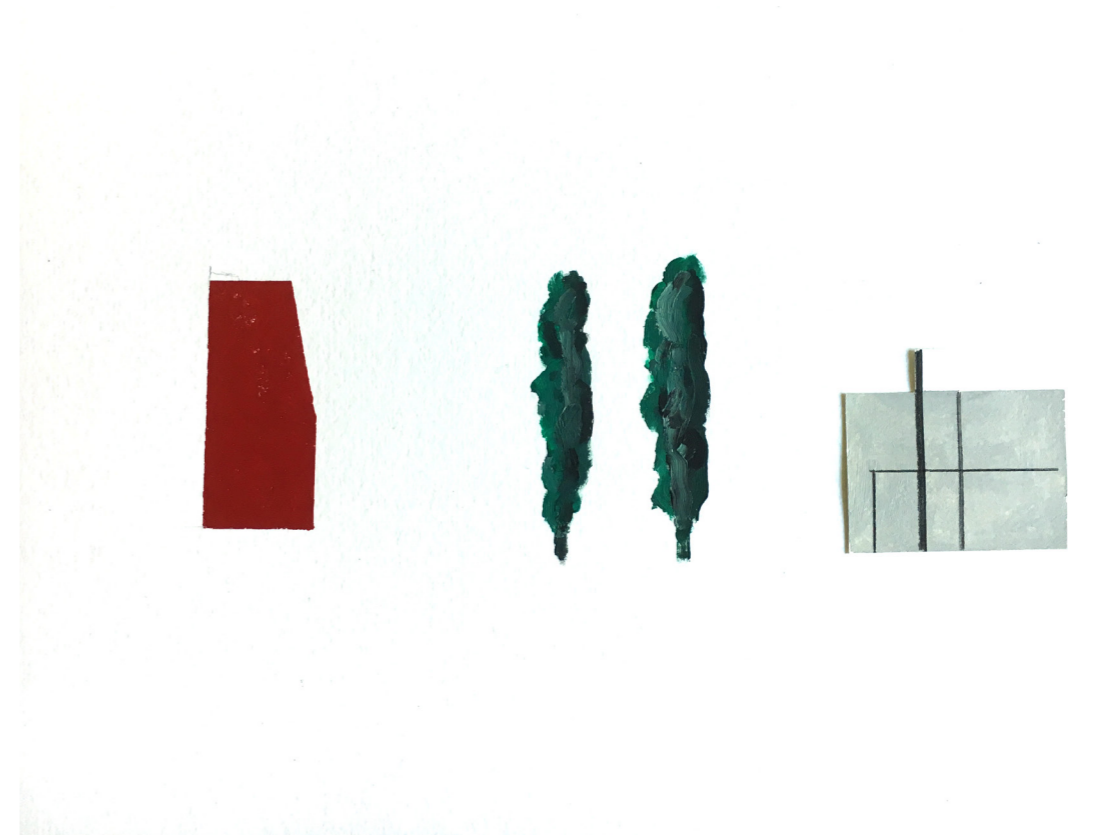
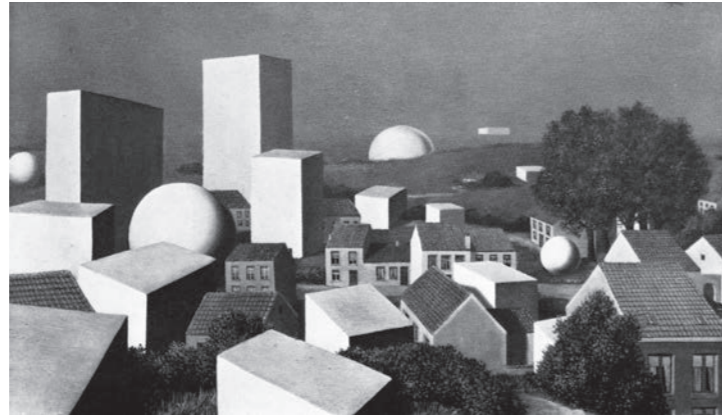

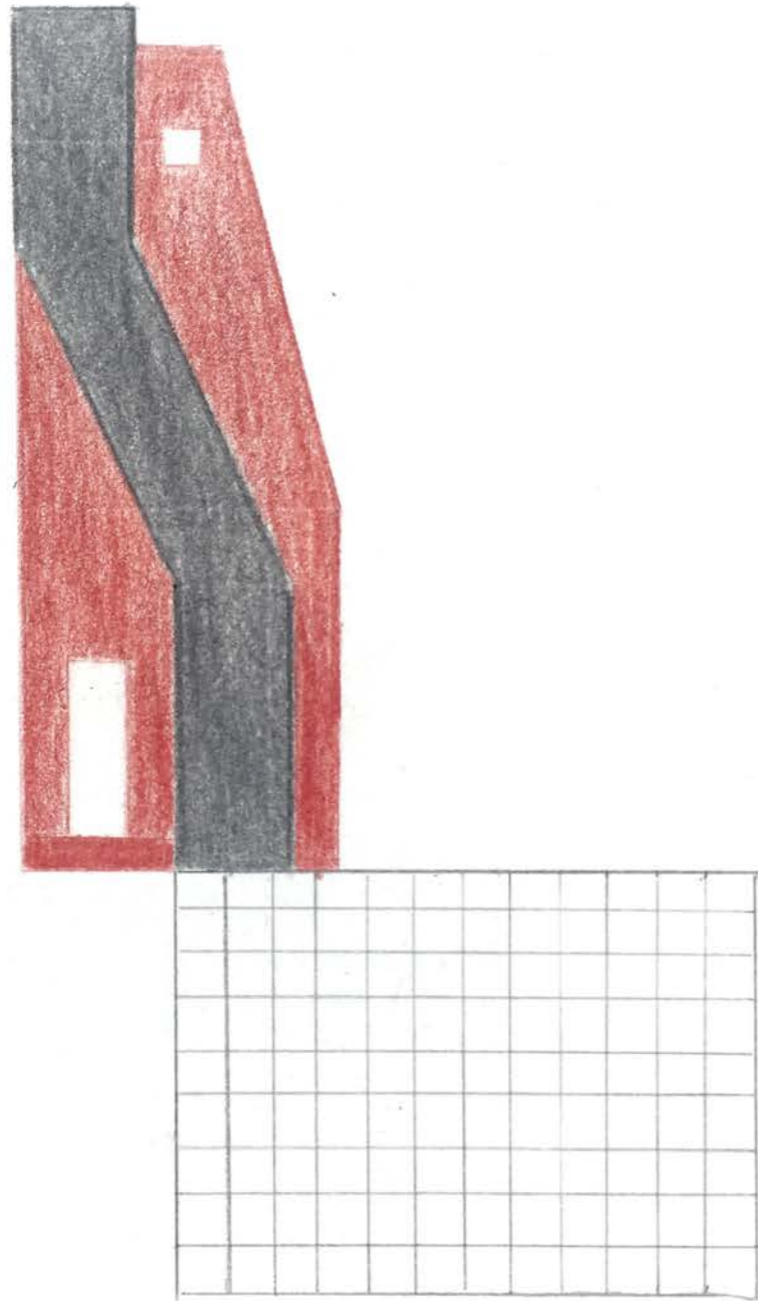

An Imagination how things can be ...

Back when the cook still lived
in the city, he had a chimney in every
room of his appartement.

He liked their polite presence,
just stepping a bit outwards each wall.

While looking at how they
disappear in the ceiling, he sometimes
wondered wether they continue to
stand still, or start to dance as they
rise towards the roof.

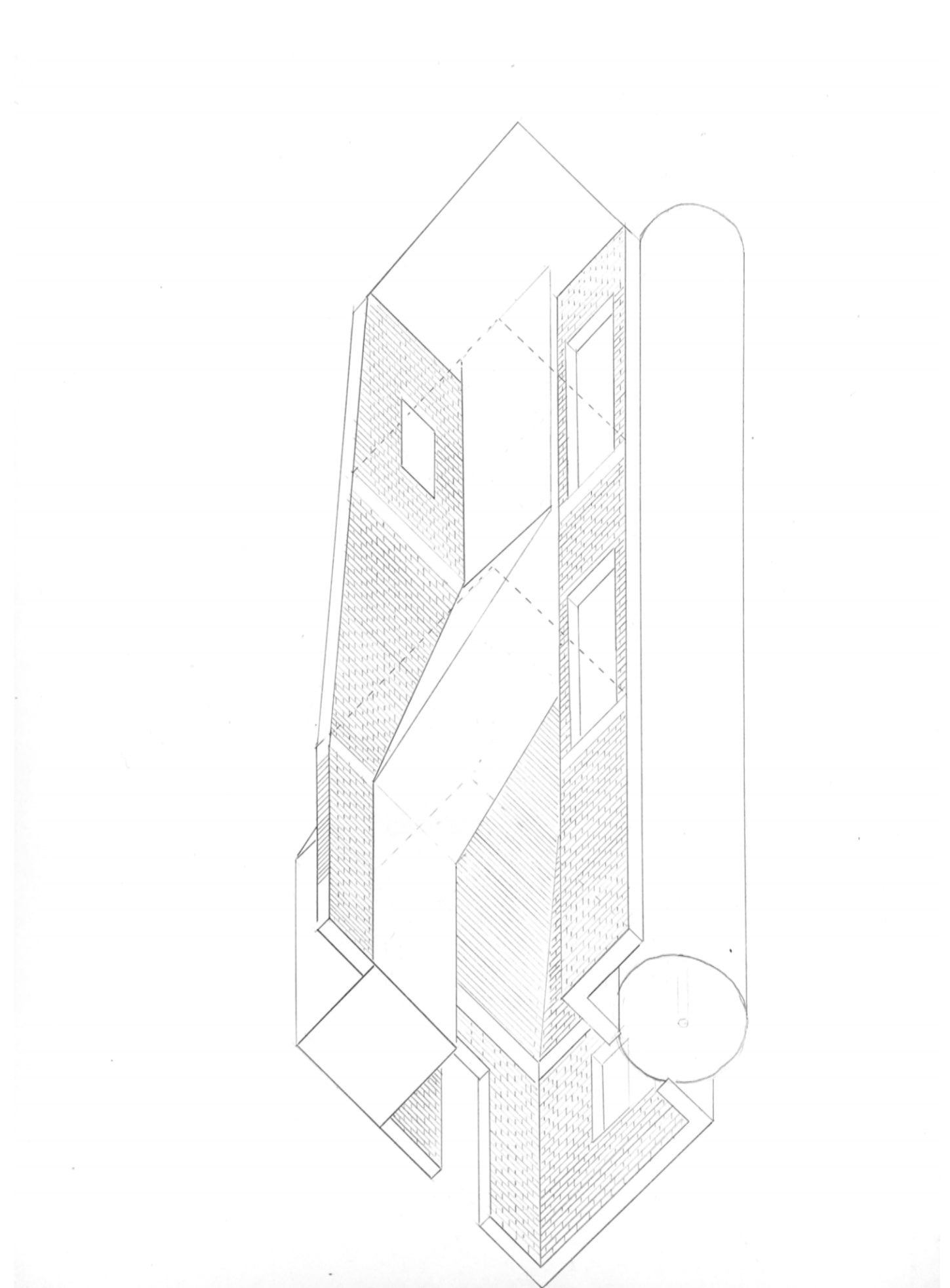

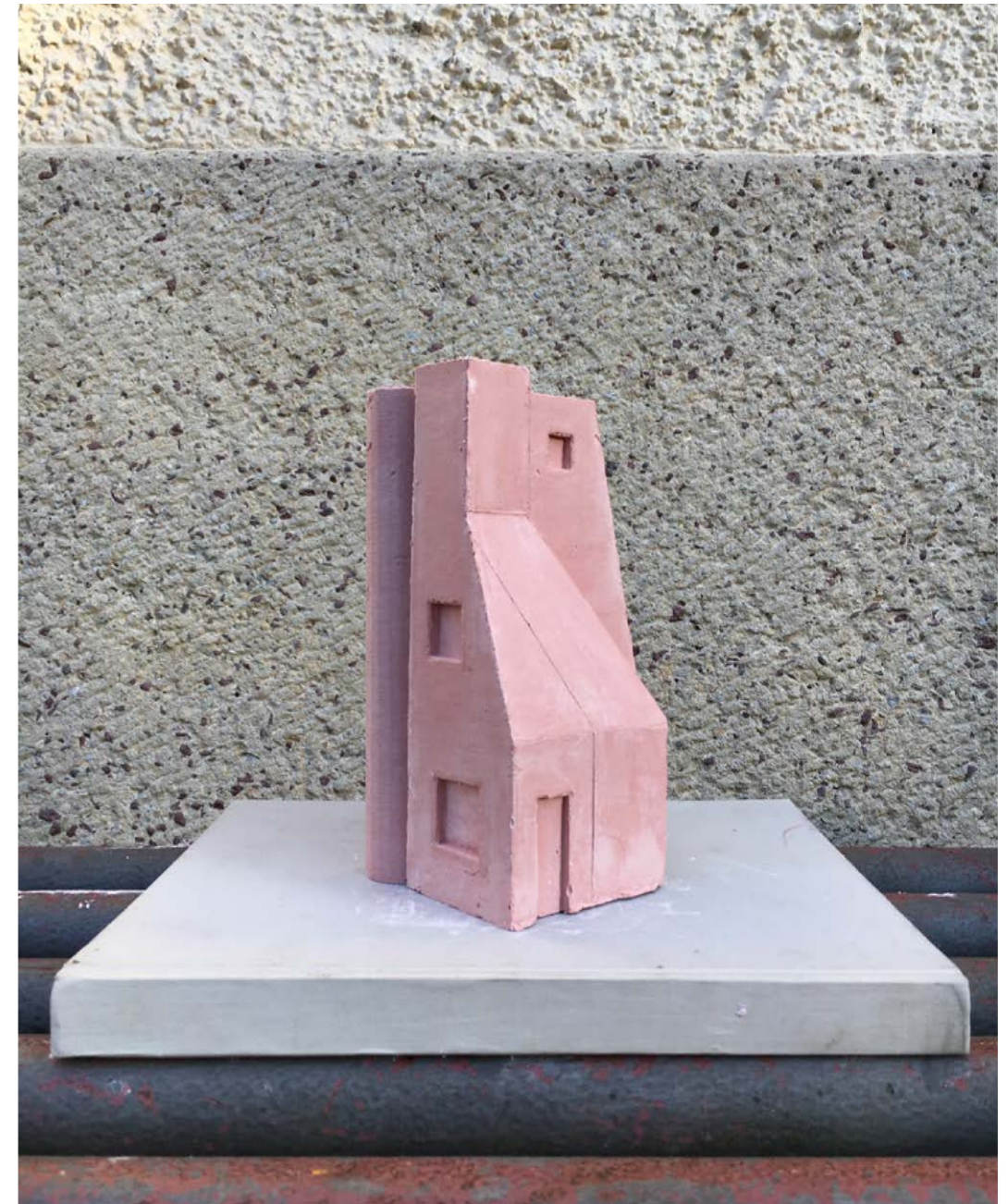

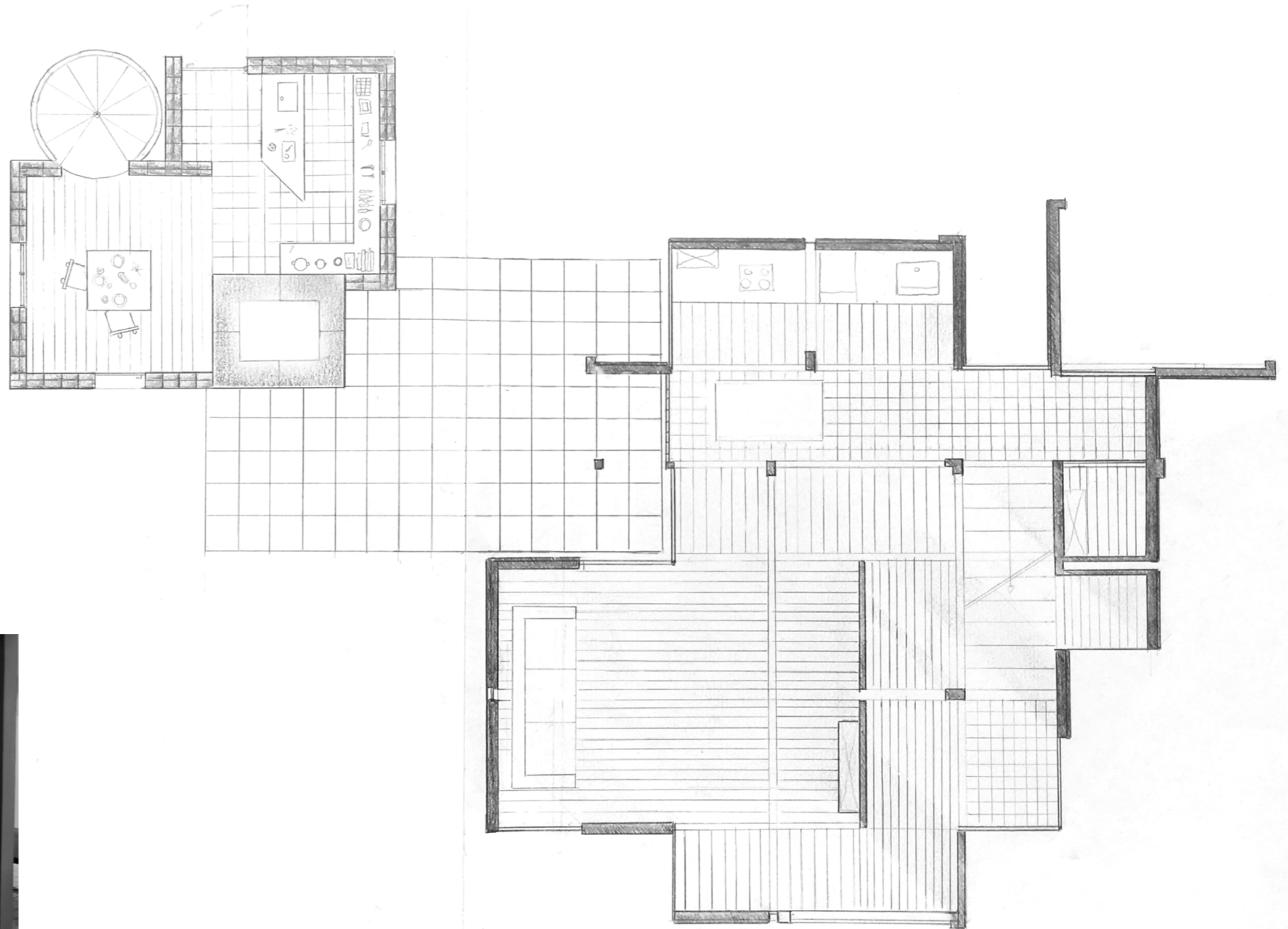

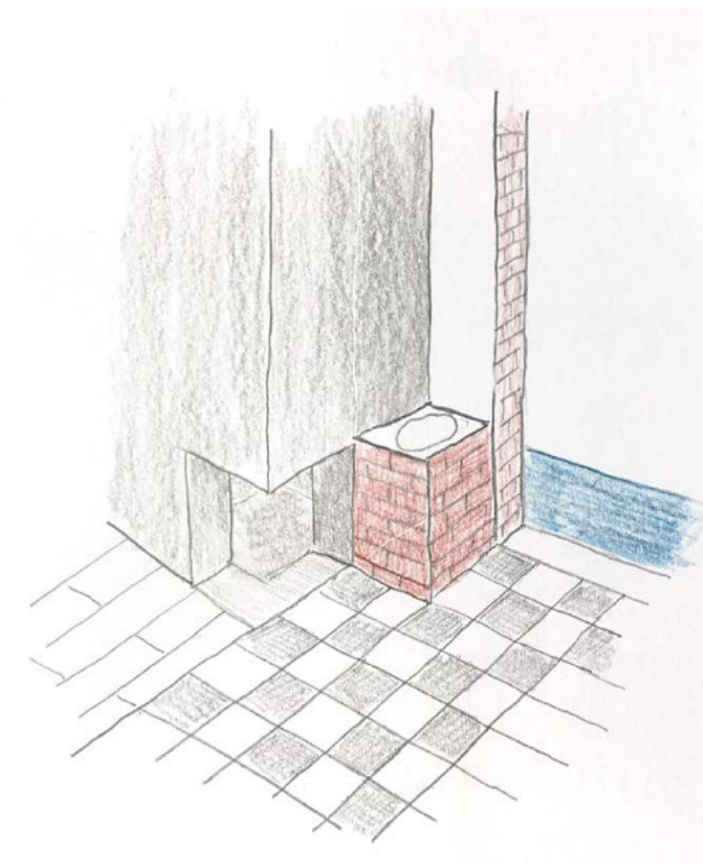

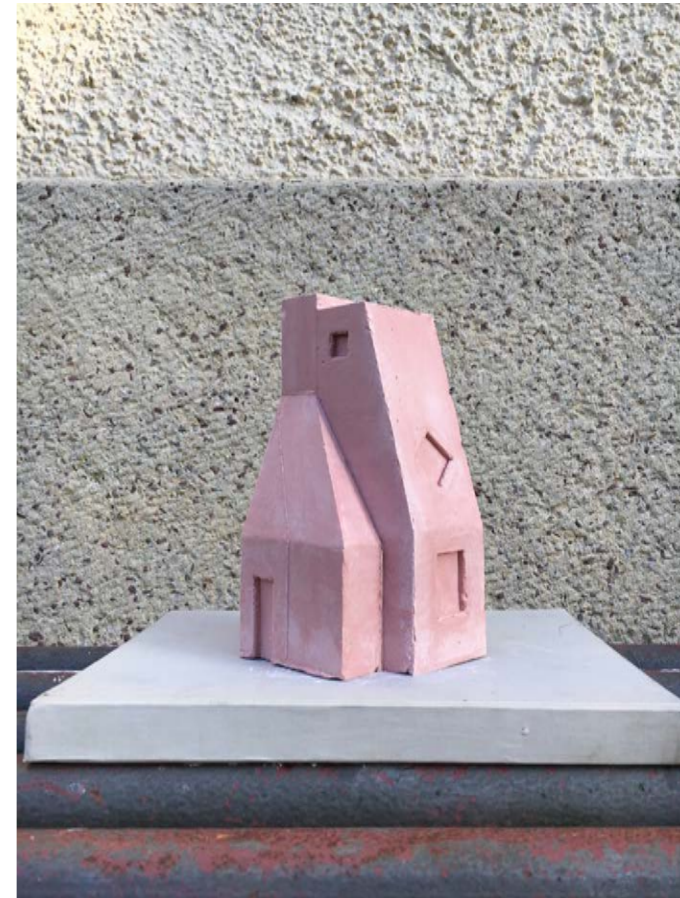
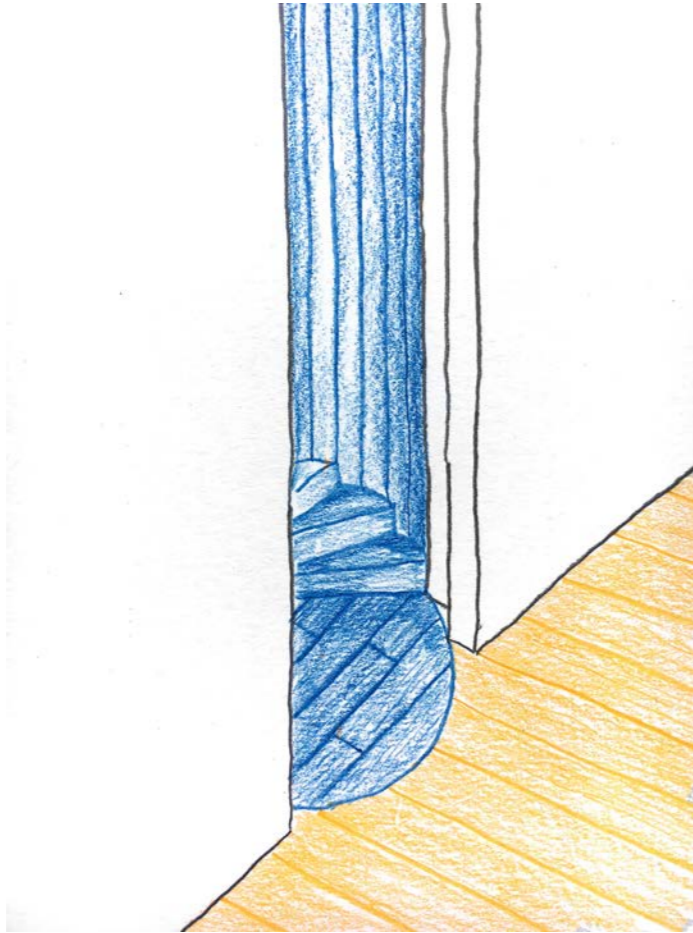

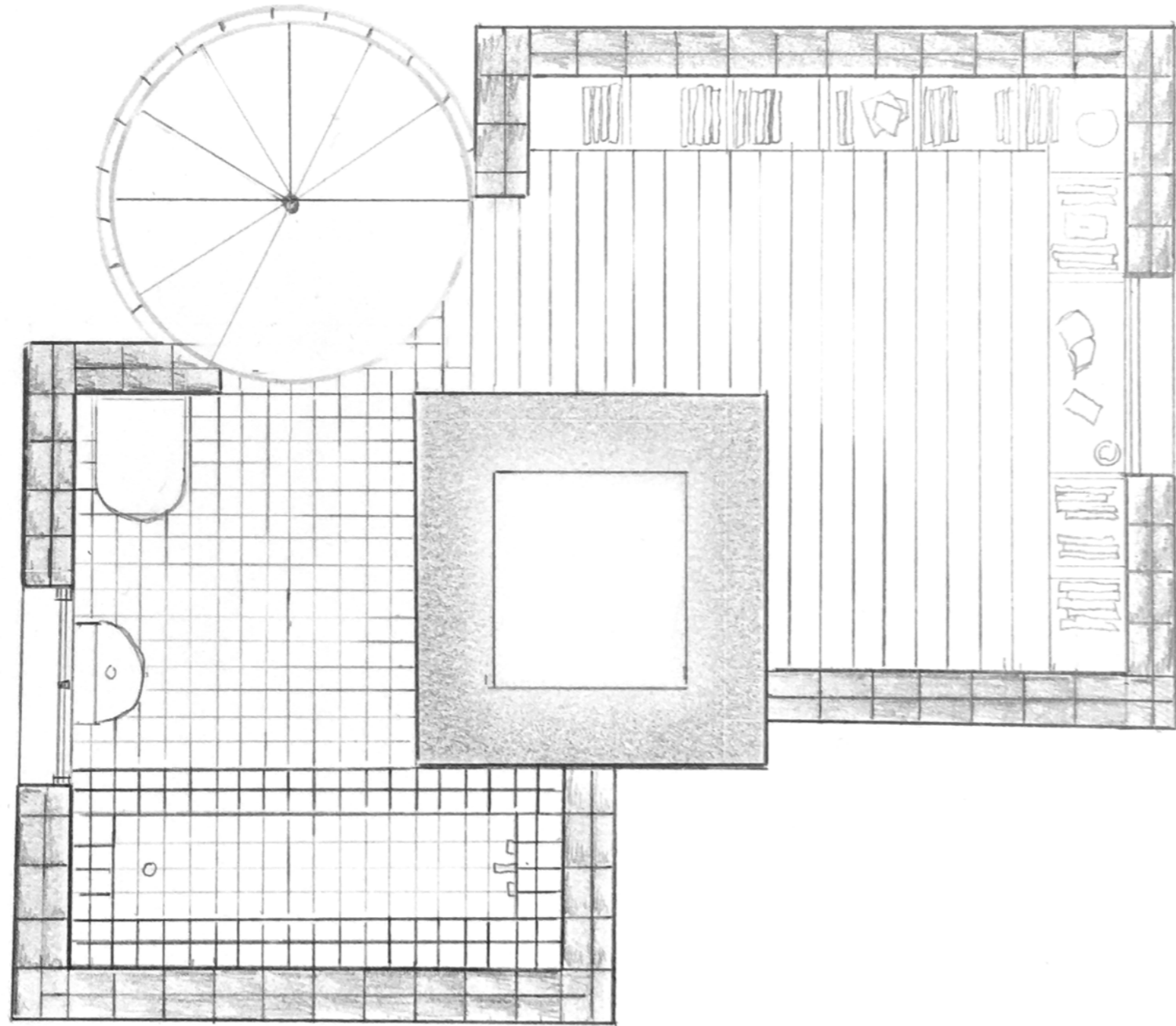

Imagining how things can be ...

As he walks up the spiral staircase to the bathroom, the warm chimney pipe seems to follow along.

One thing that he enjoys the most, is the water not losing its temperature while bathing.

Leaning his back against the warmth he could look outside the window into the forest.

He put in two logs of wood in the fire, knowing it would keep him warm for a while.

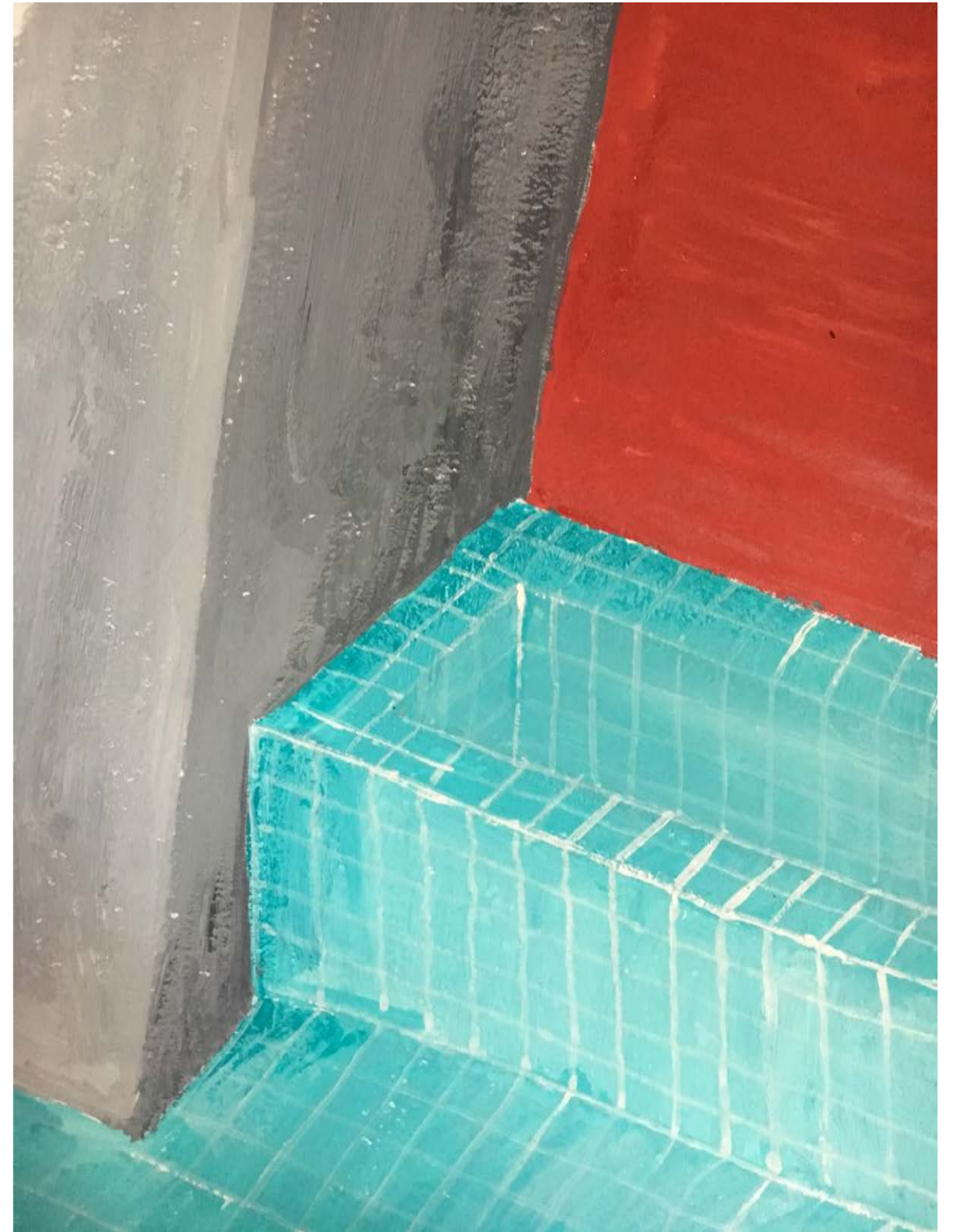

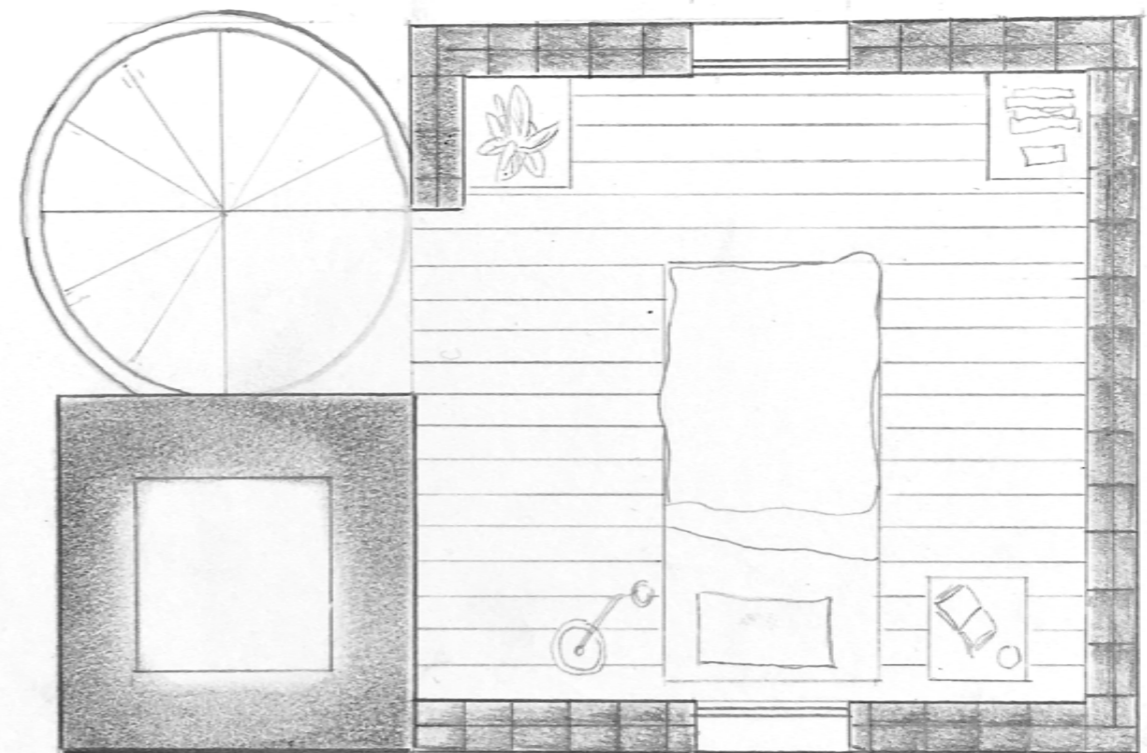
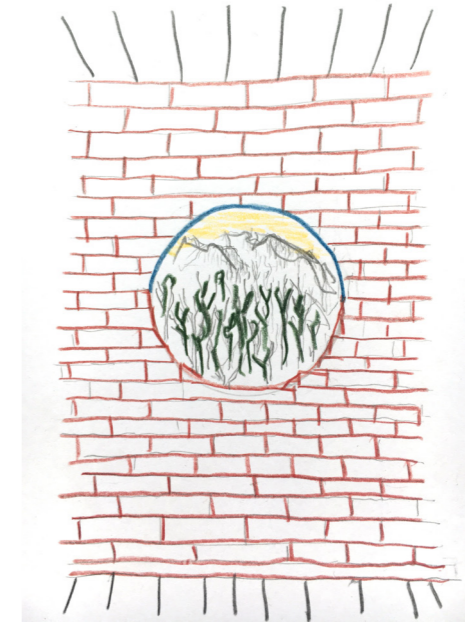
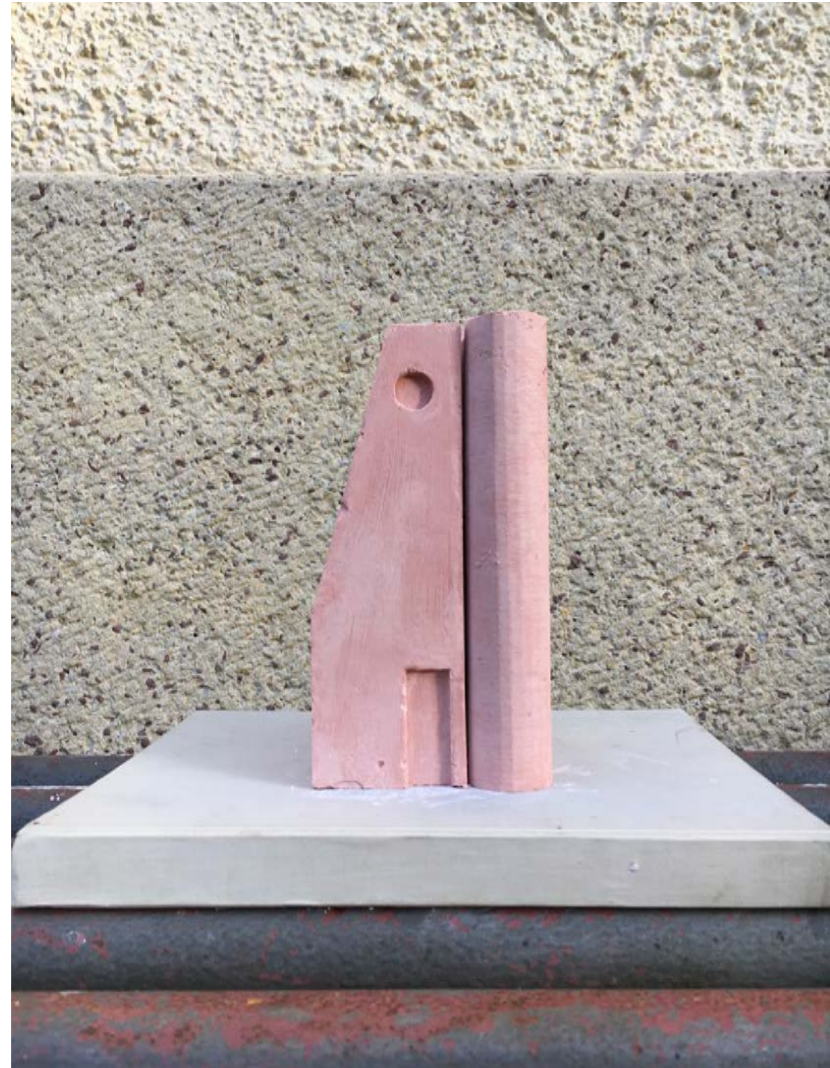

... and the house with the missing chimney

“In 1972, when the planning began, my husband wanted a fireplace because, to him, burning logs in the winter meant extra warmth and a communal gathering spot...”

“...We never knew what happened, but a fireplace was never indicated in the plan...”

- Suzanne Frank, the clients response

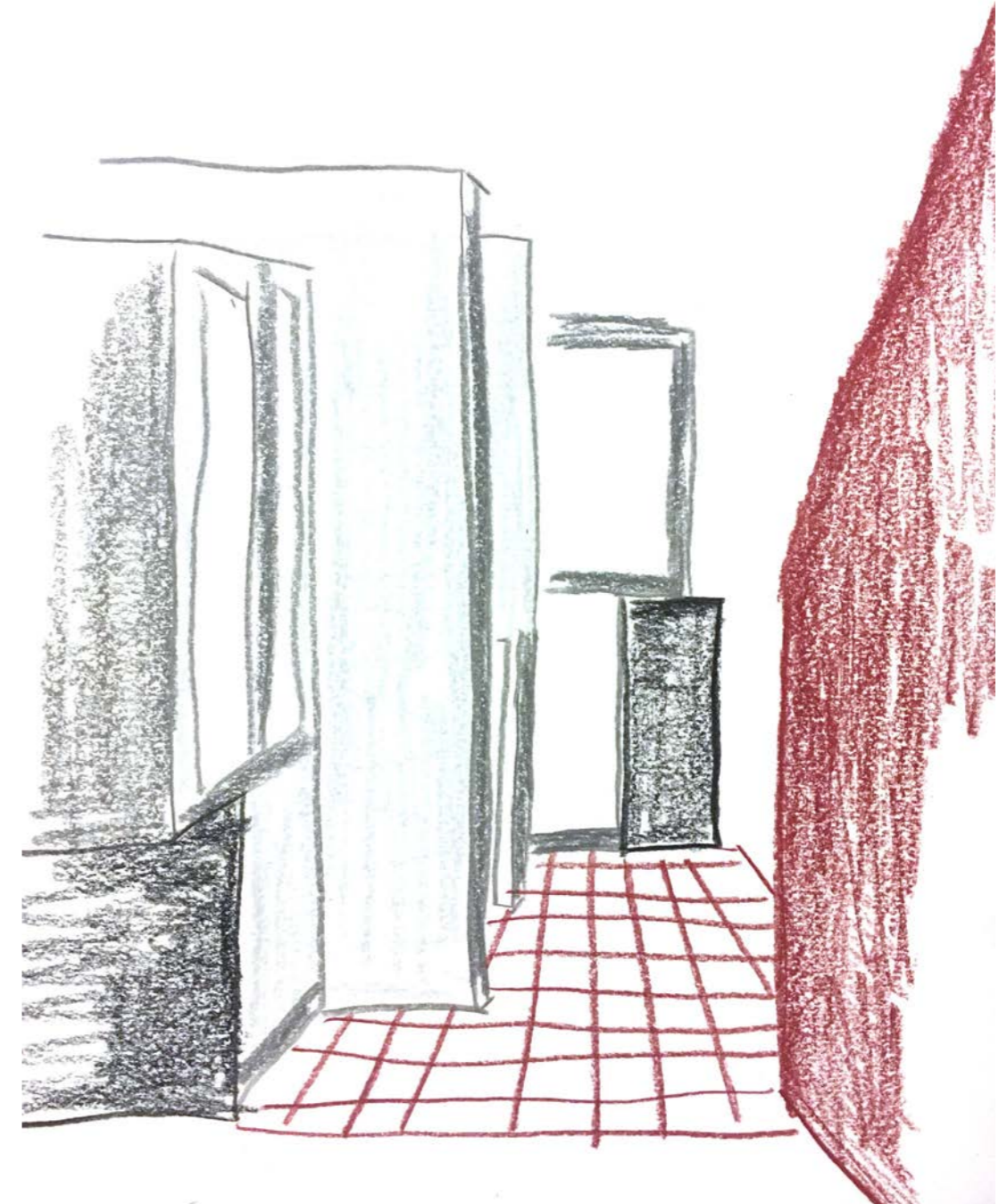

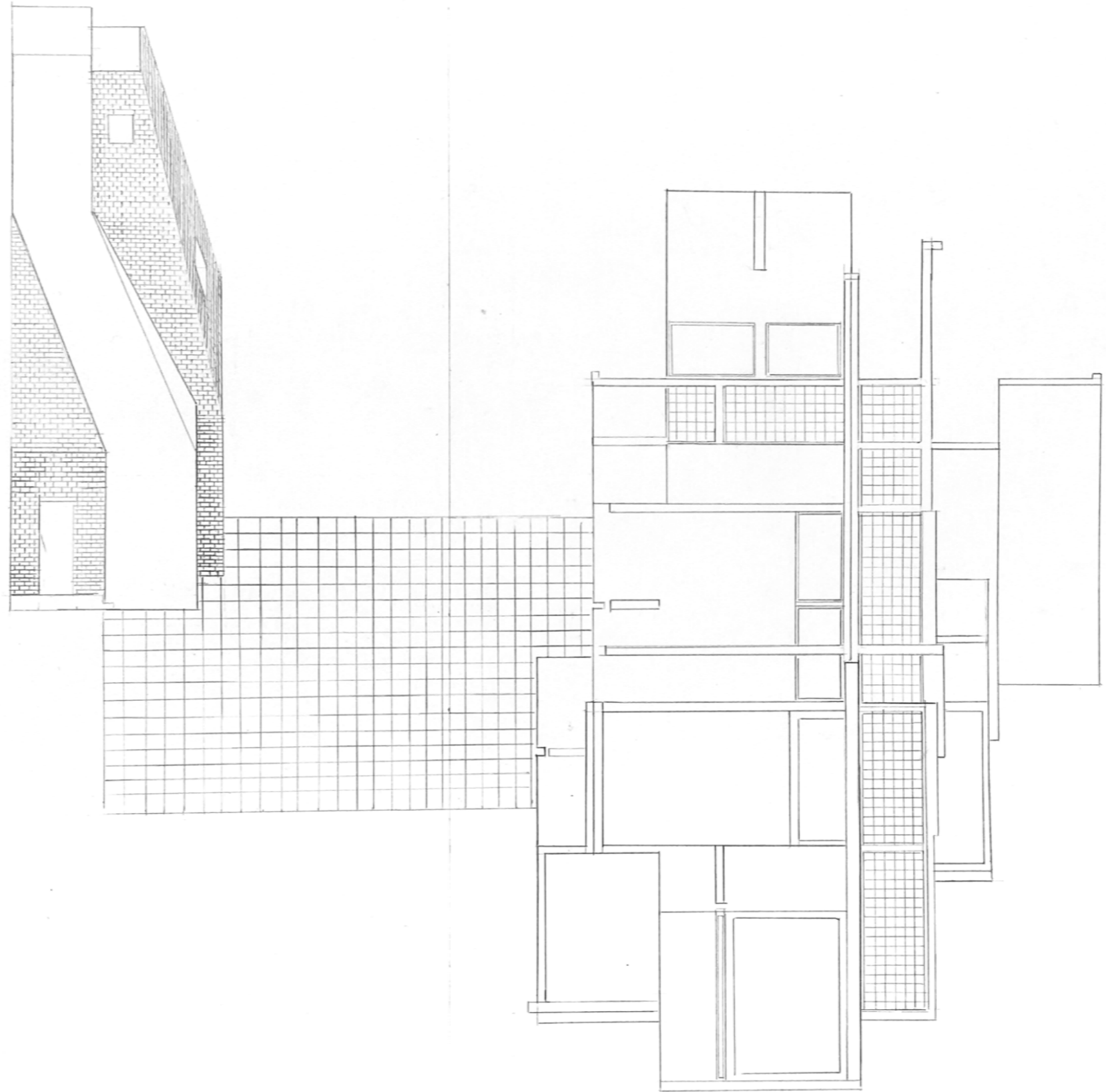

Movement 2



CH in US: House for a daughter

There I am, out in the open in my parent's house.

Their gaze is upon me, like an omnipresent companion. Through the window, I can barely see the contours of my house.

But as the night begins to fall on the house and its inhabitants, the need to leave it becomes almost overwhelming.

Quietly, I leave the warmth of this home and walk through the garden, along the trees.

And there it is. Tall and lonely.

I step forward, relieved. Light is on in the kitchen.



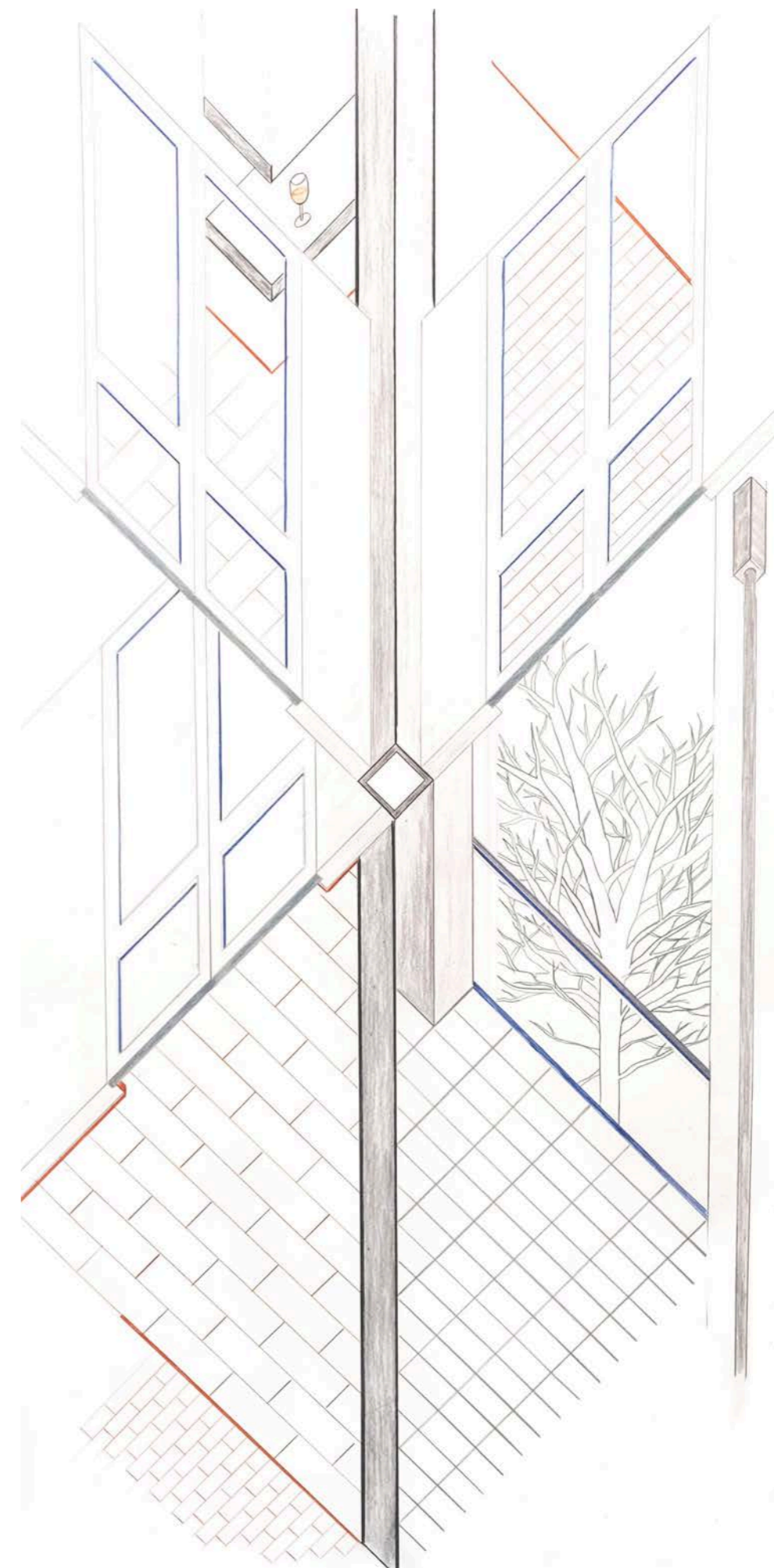

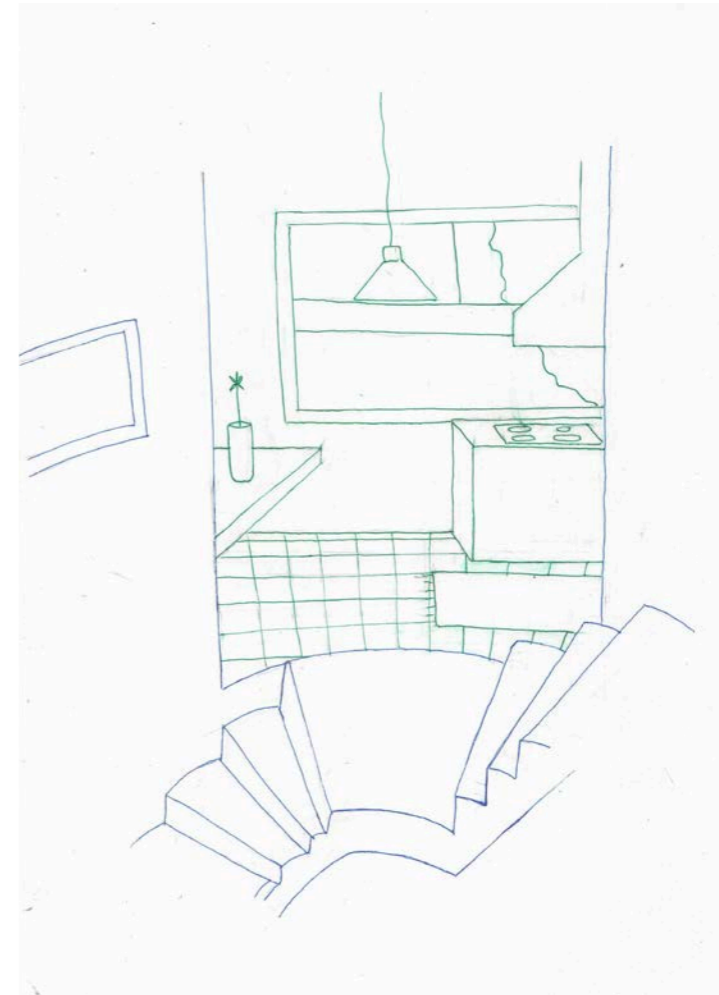
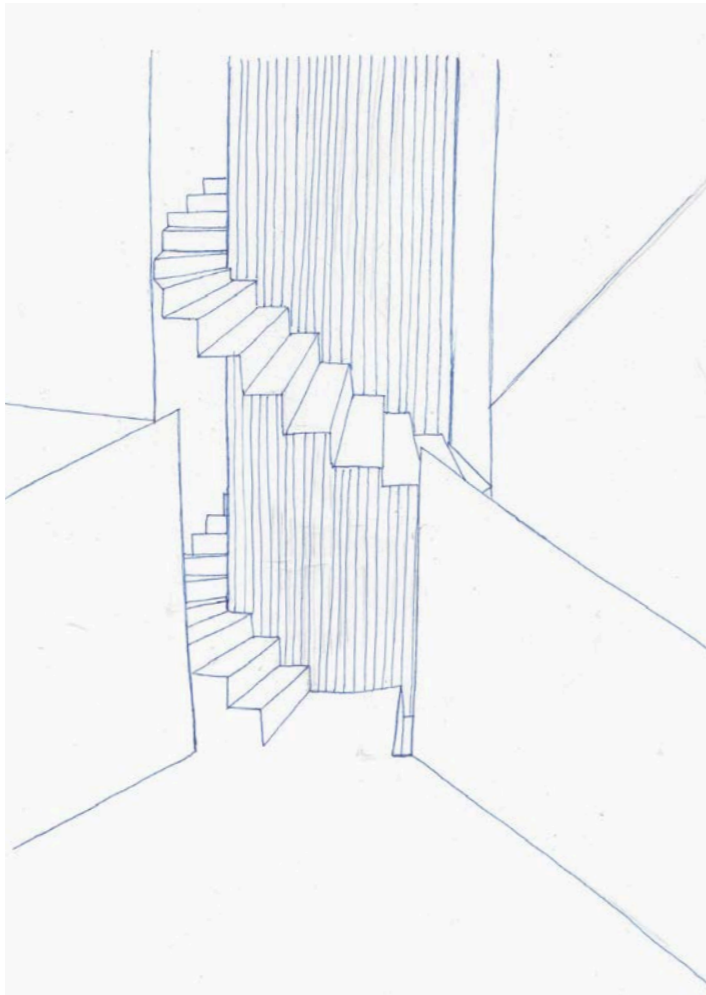

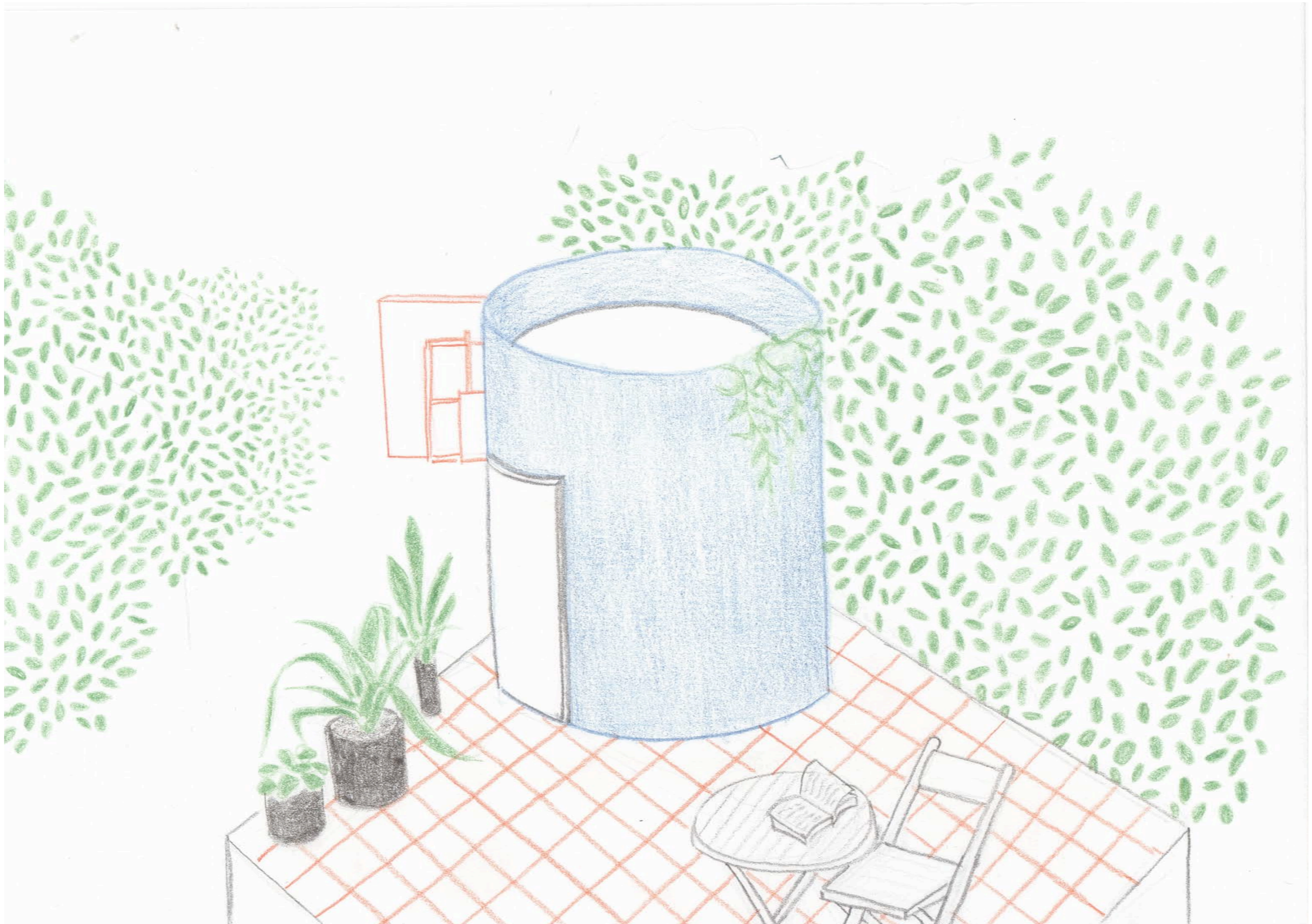

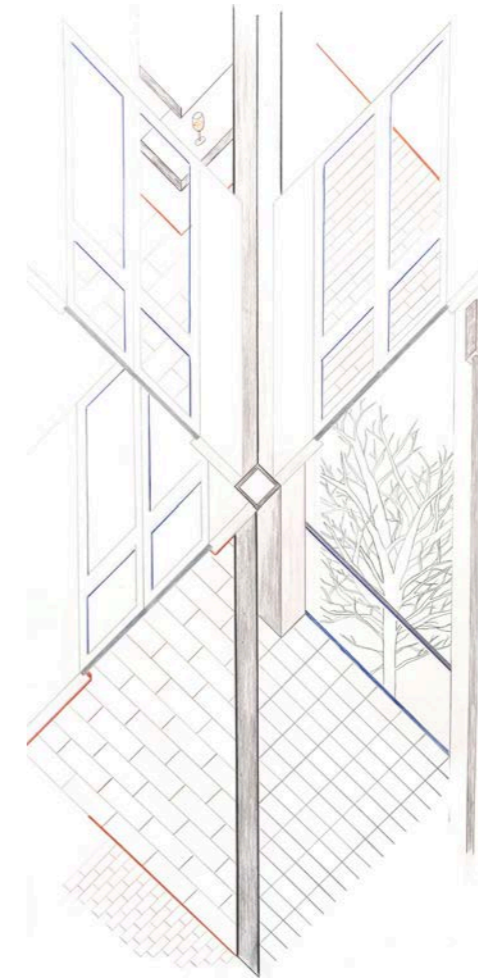
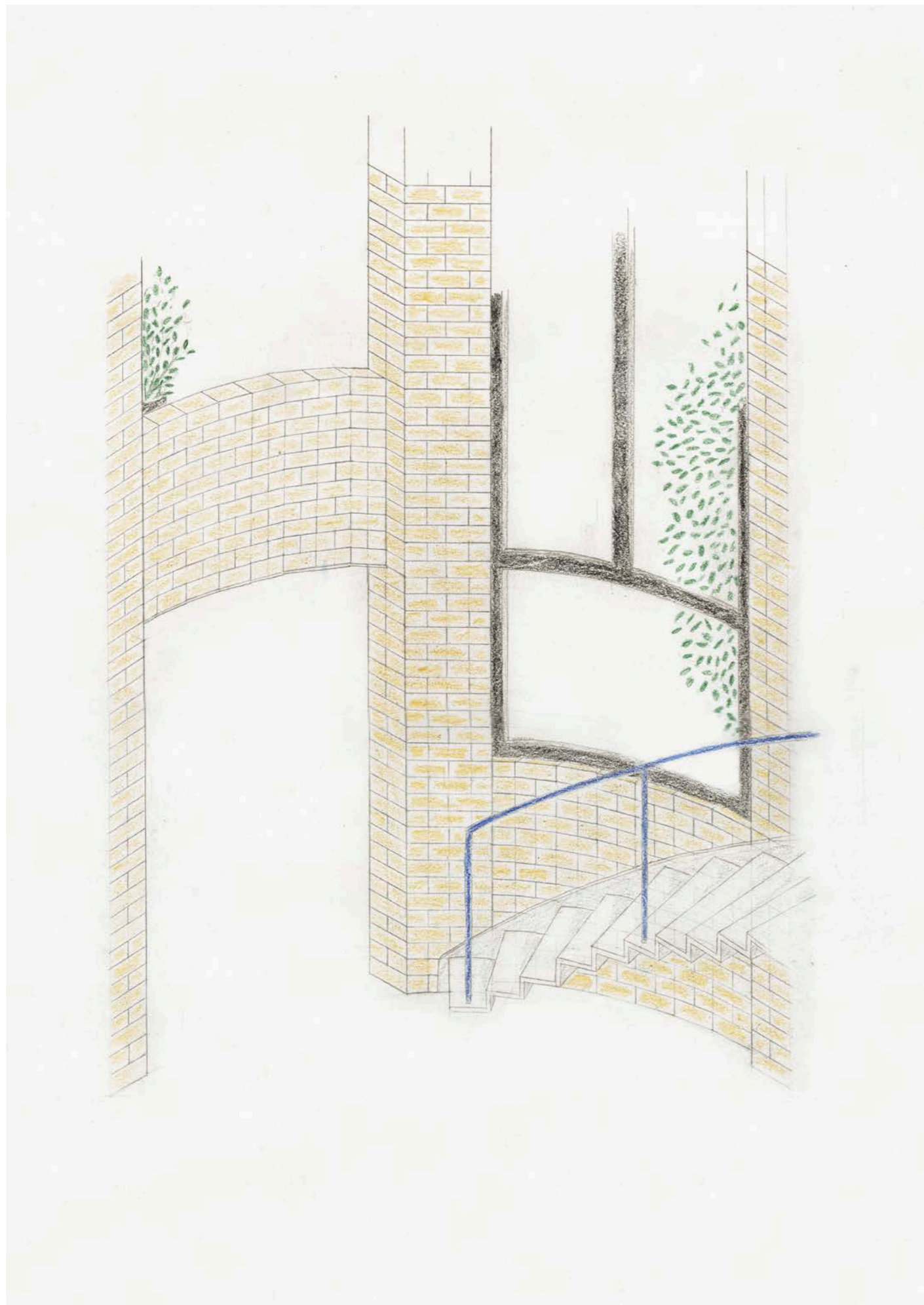

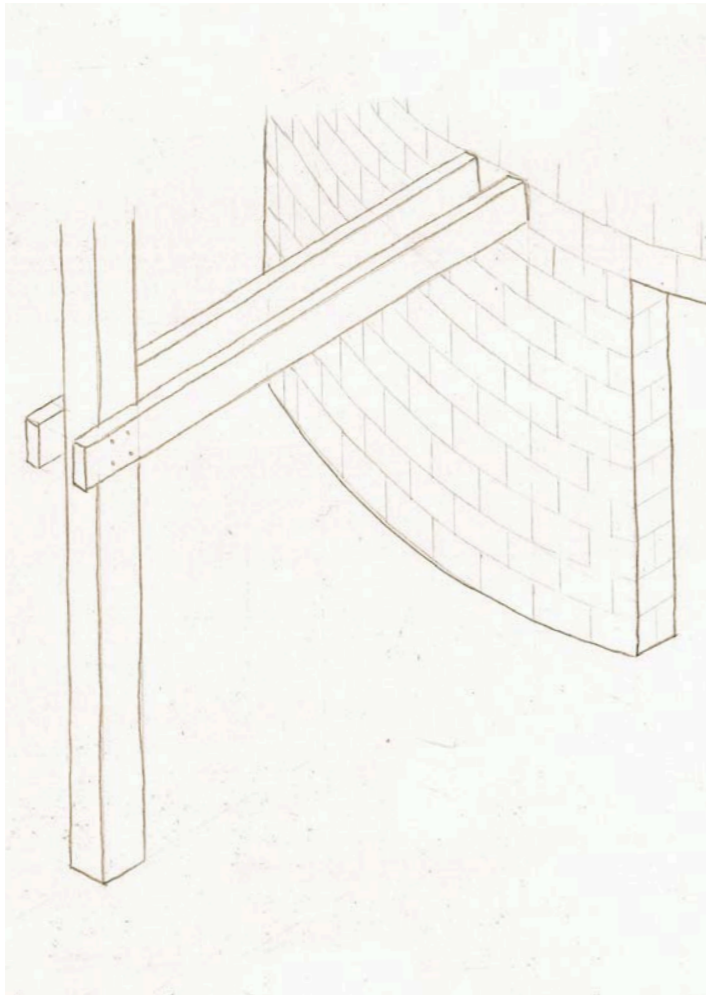

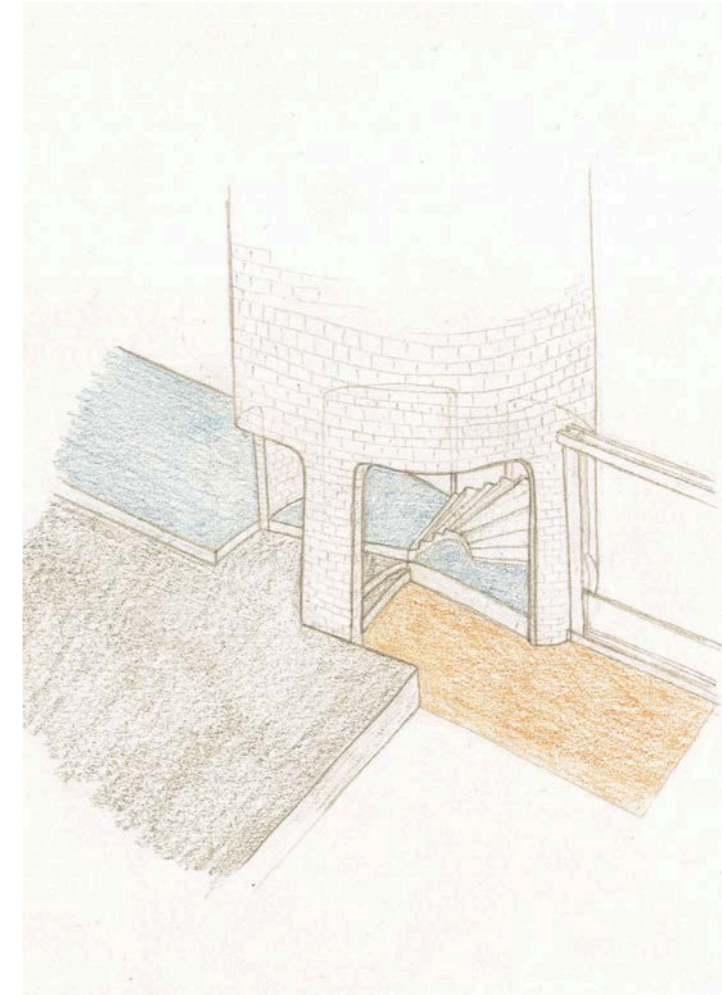
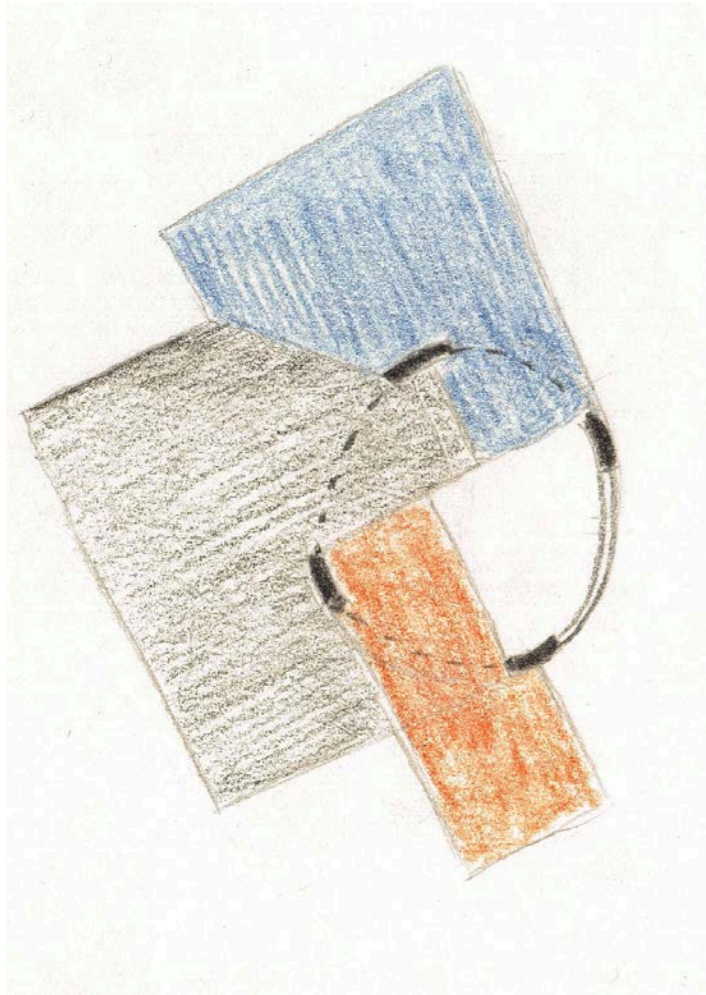

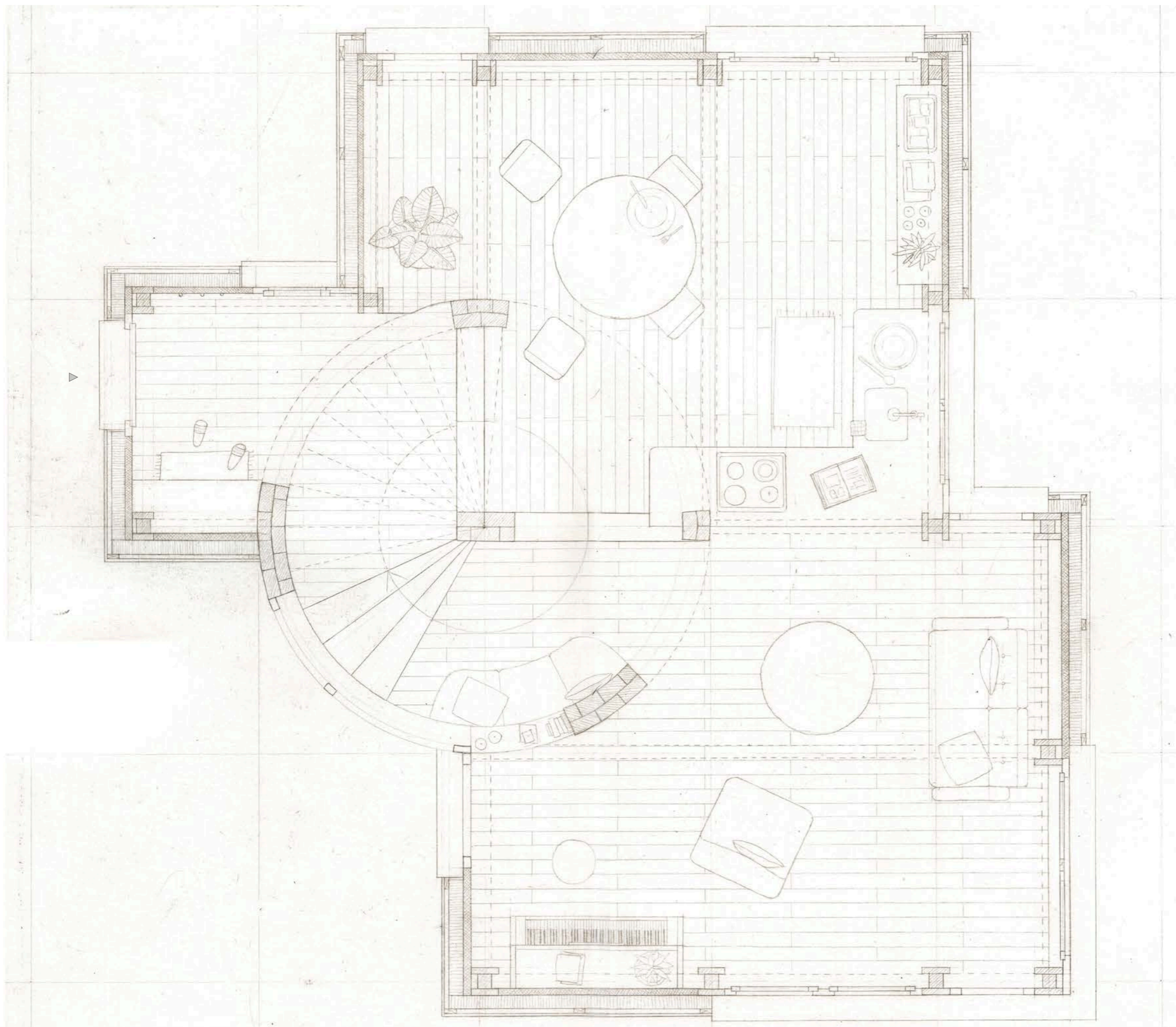

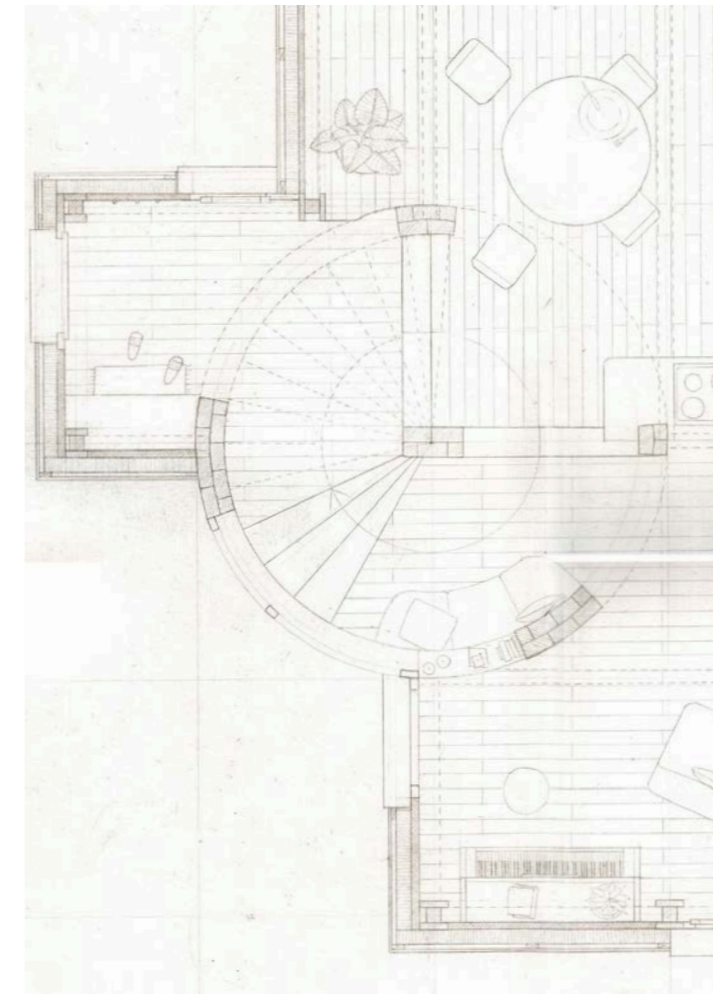

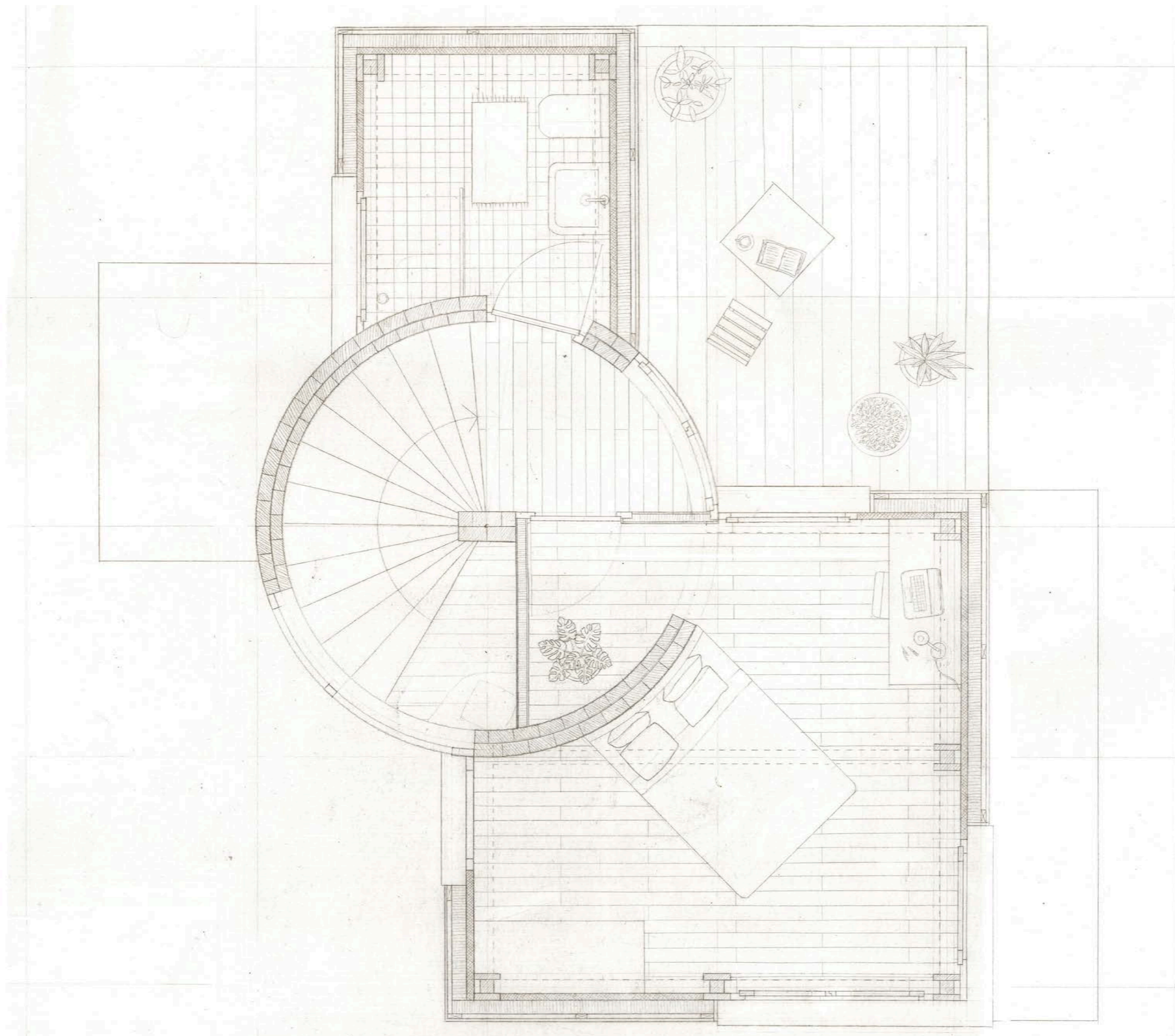

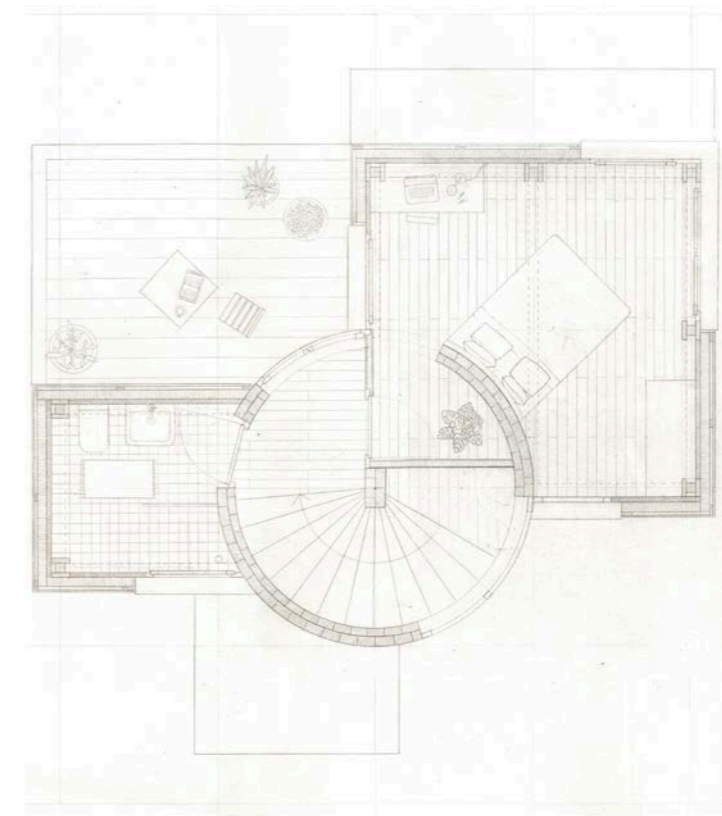
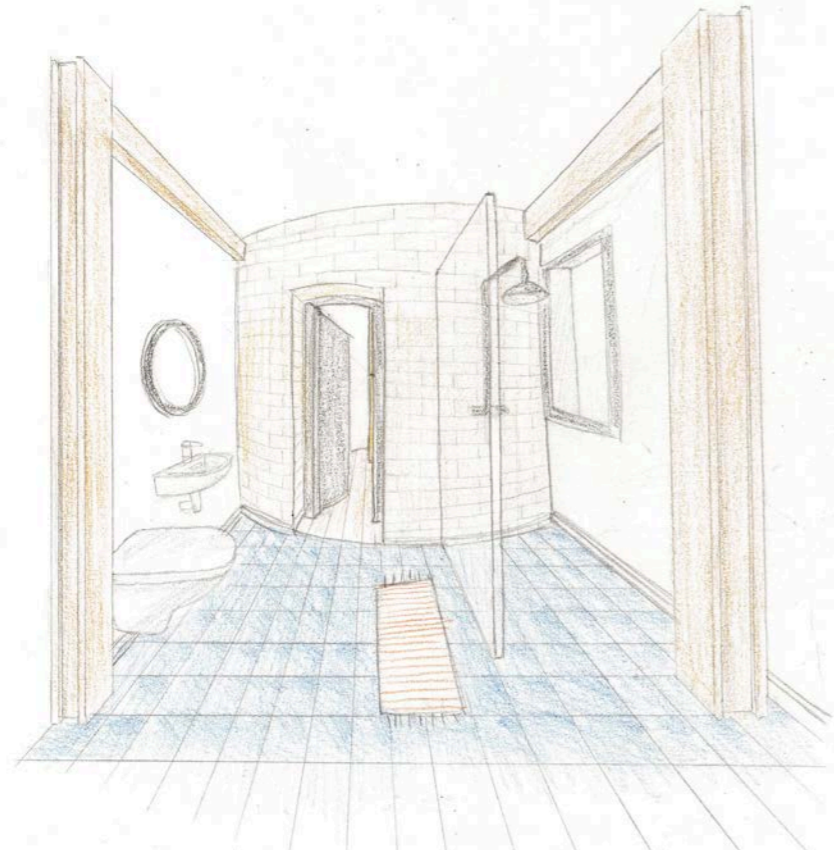

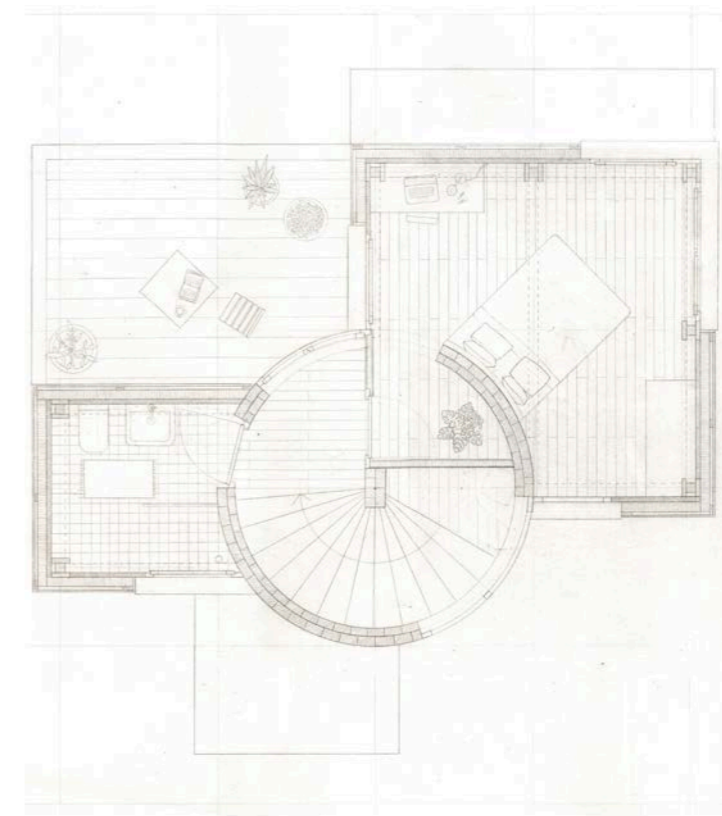
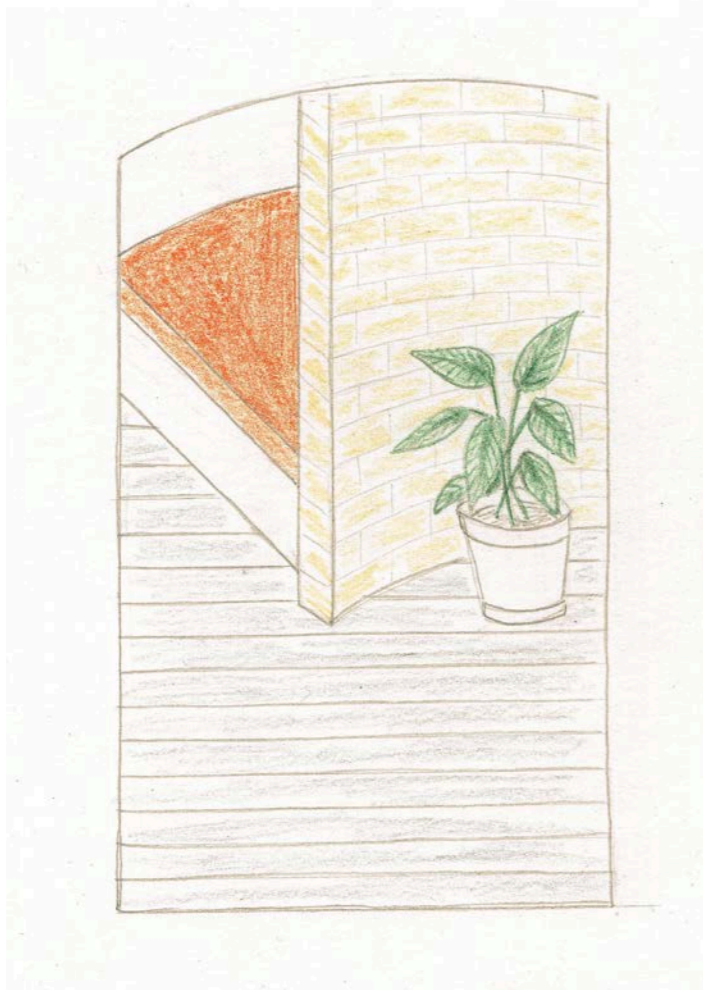

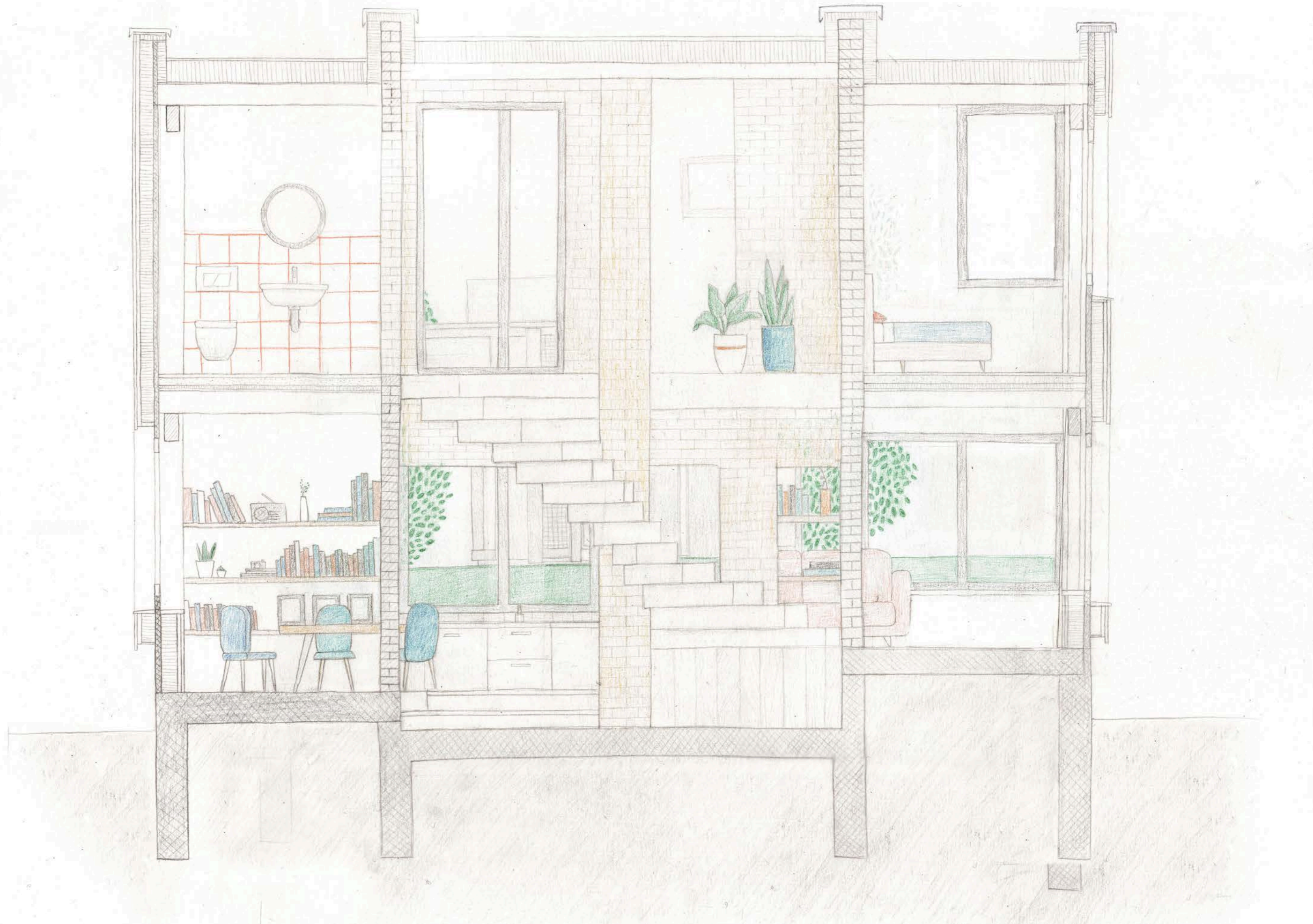

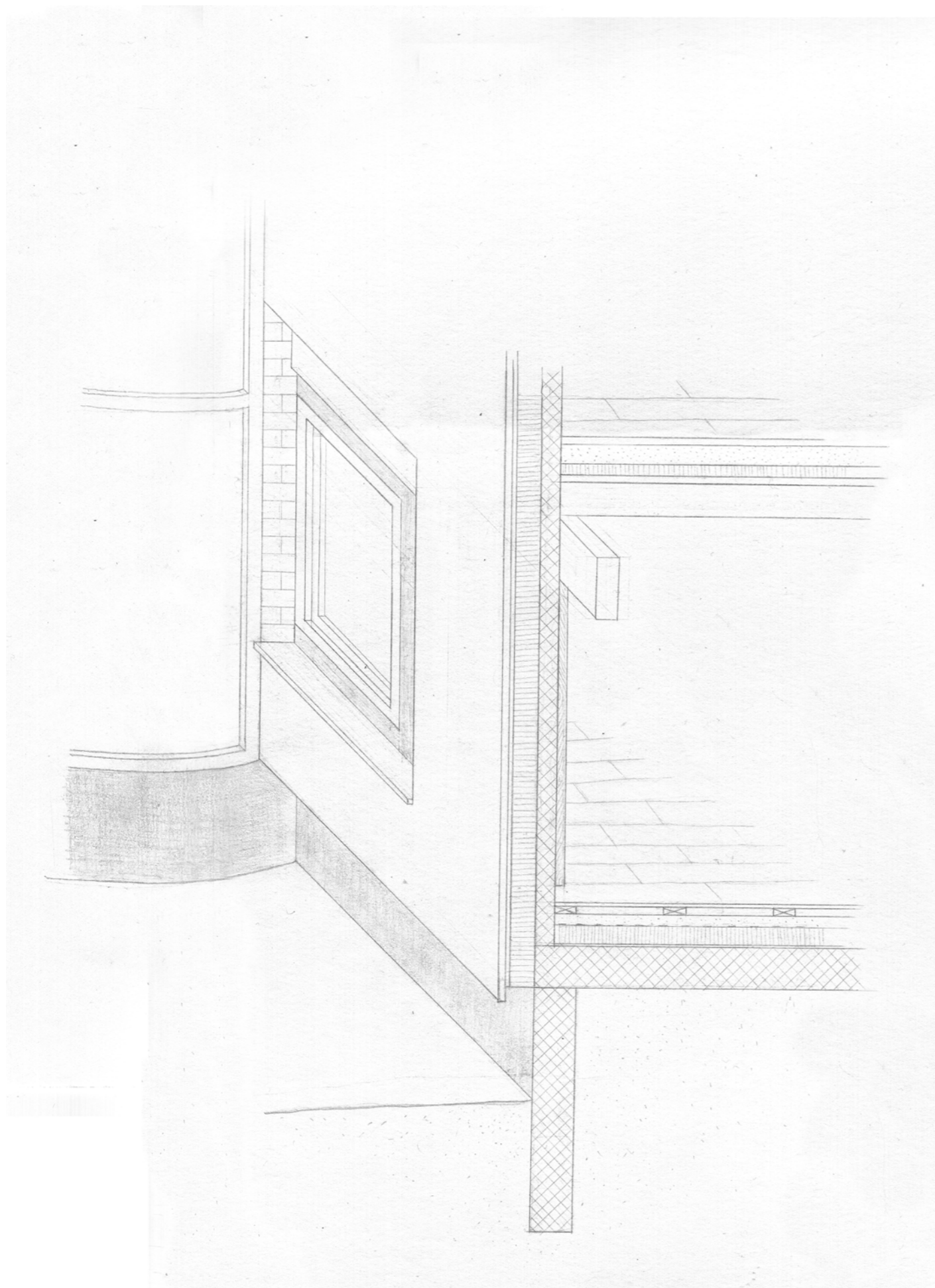



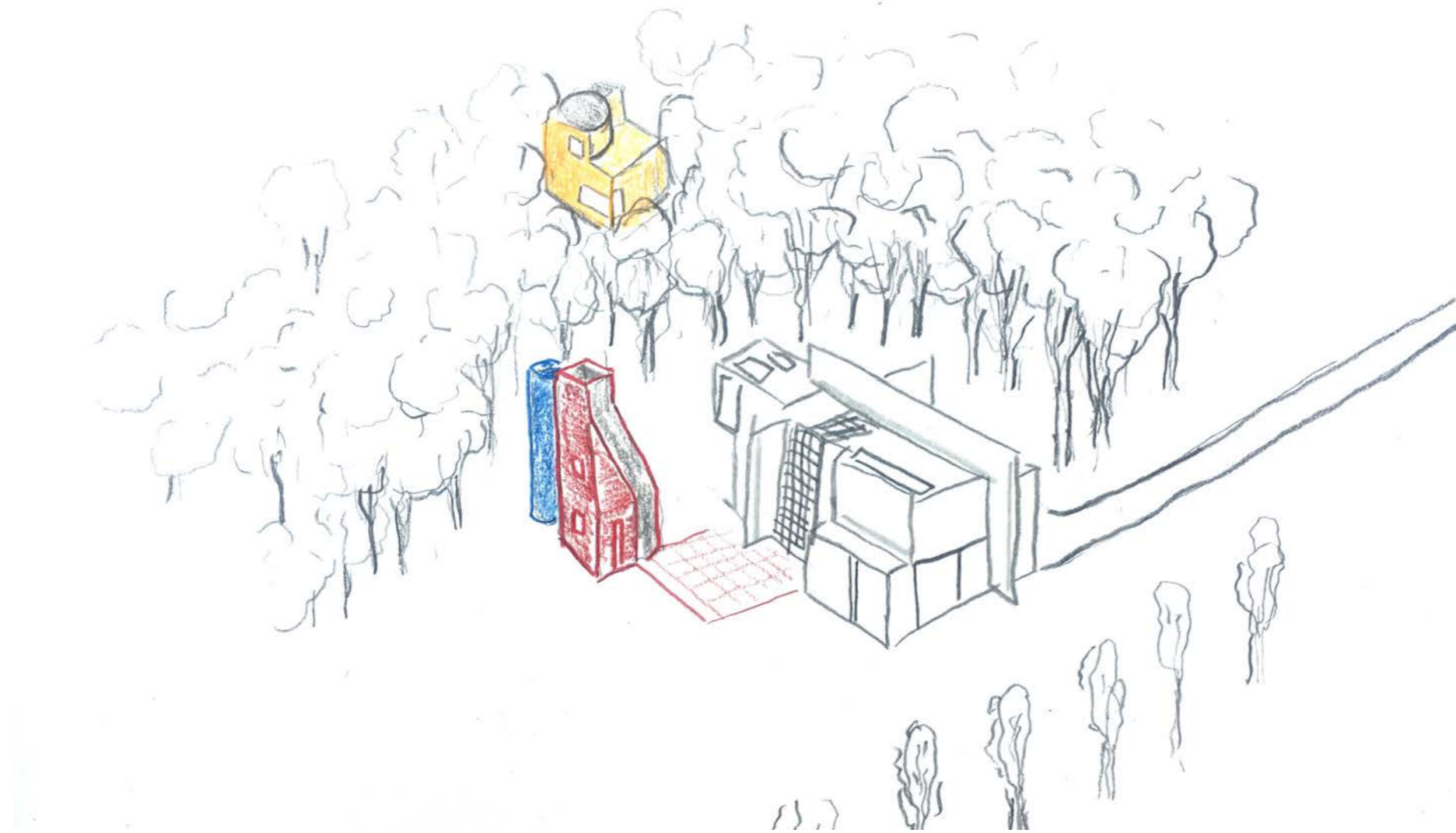

Movement 2

Switzerland

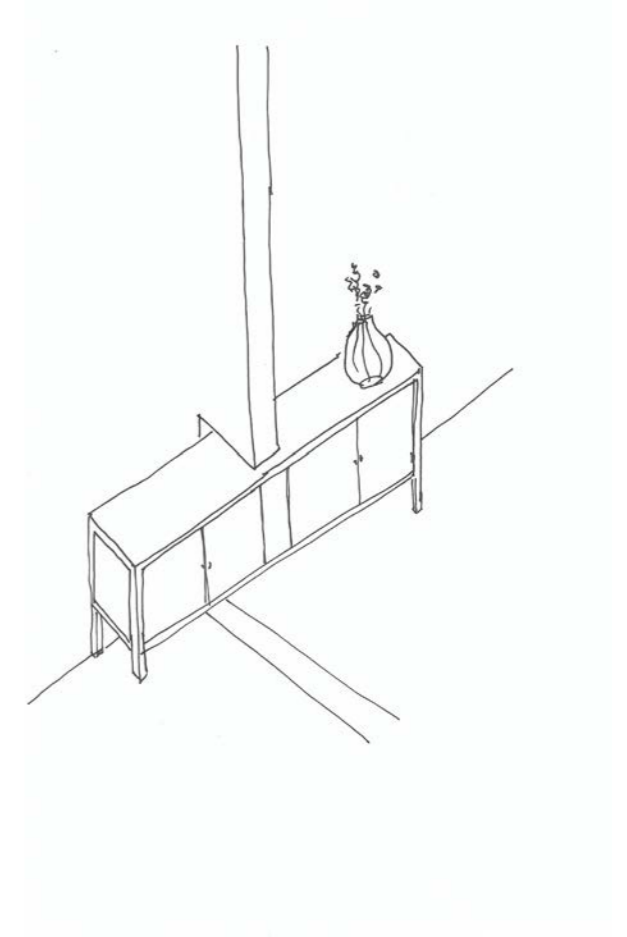
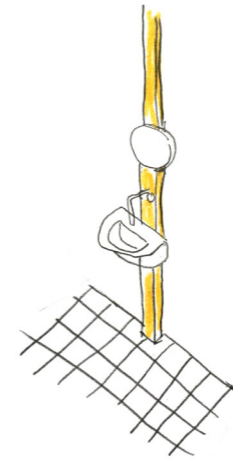

Movement 2

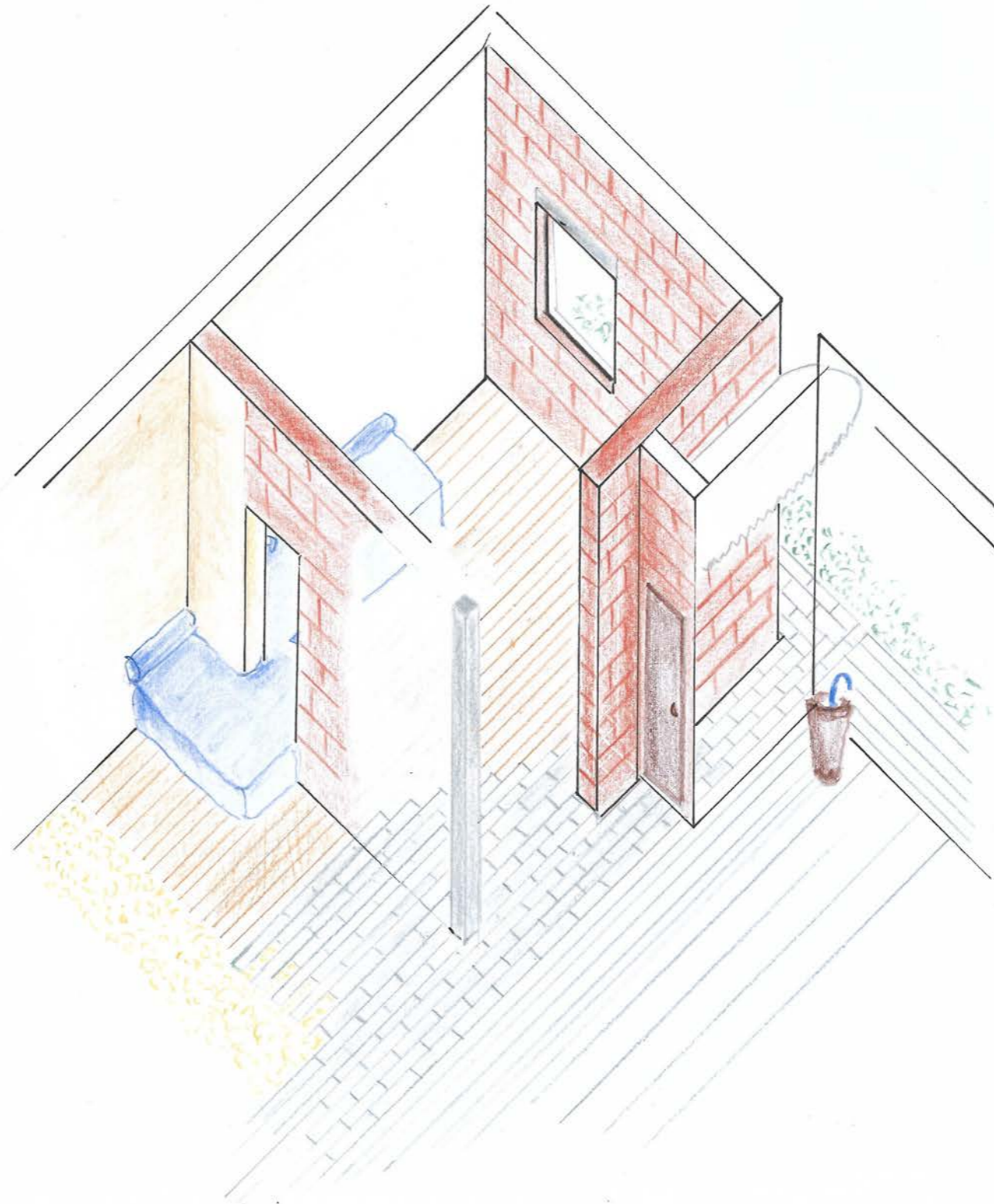

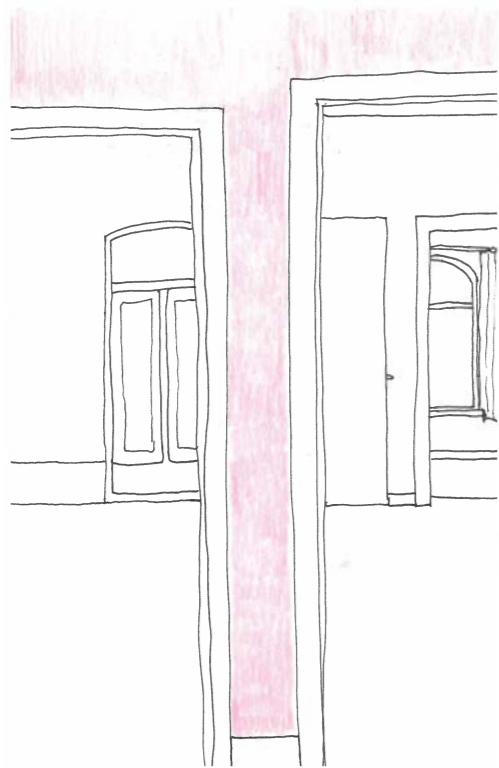

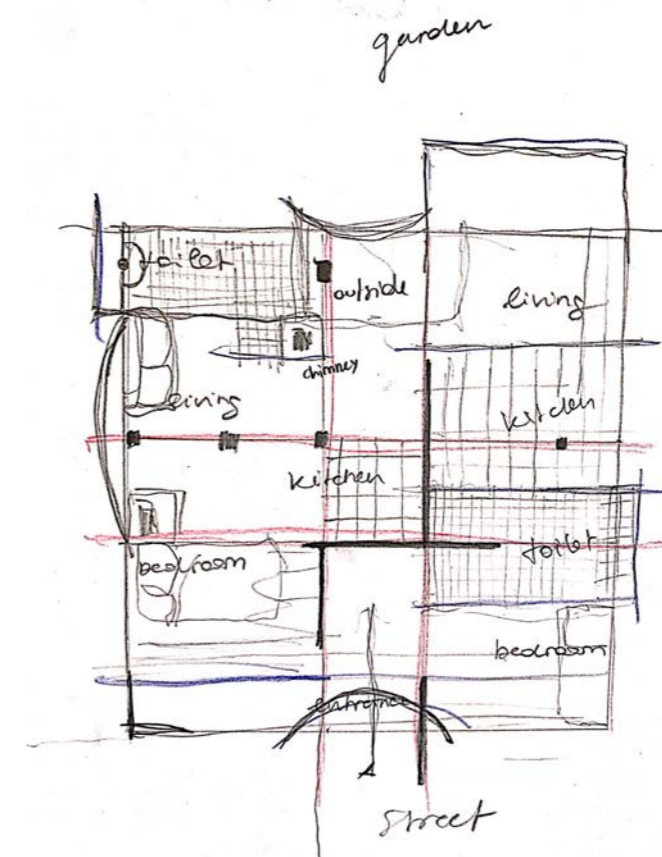

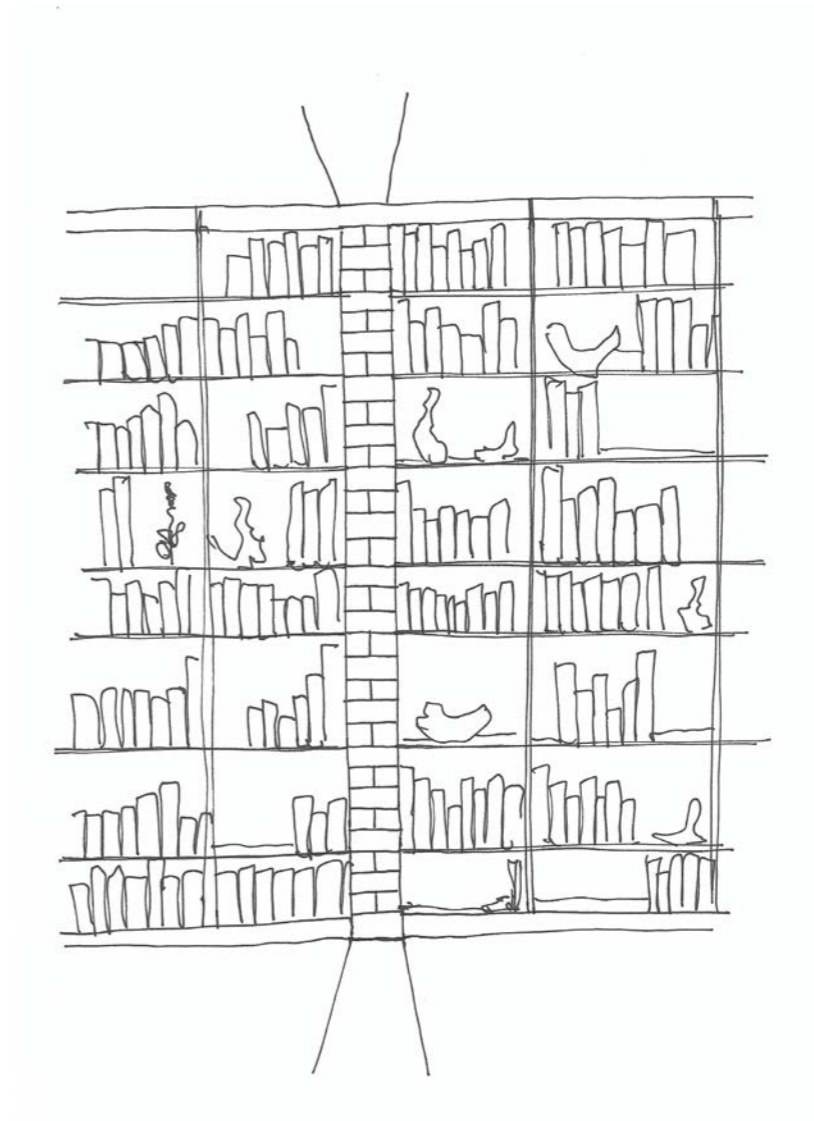
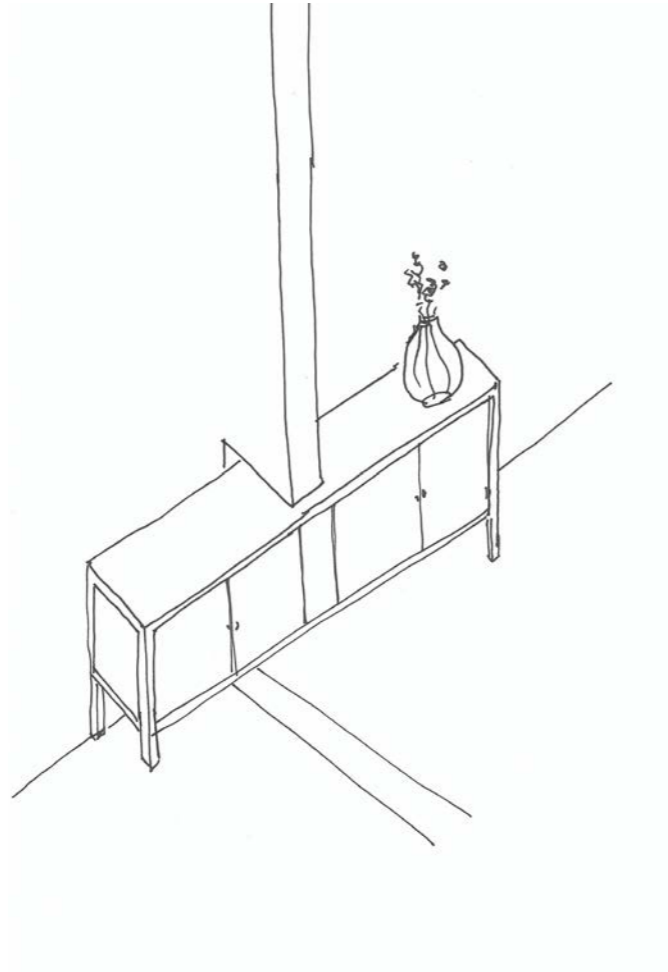

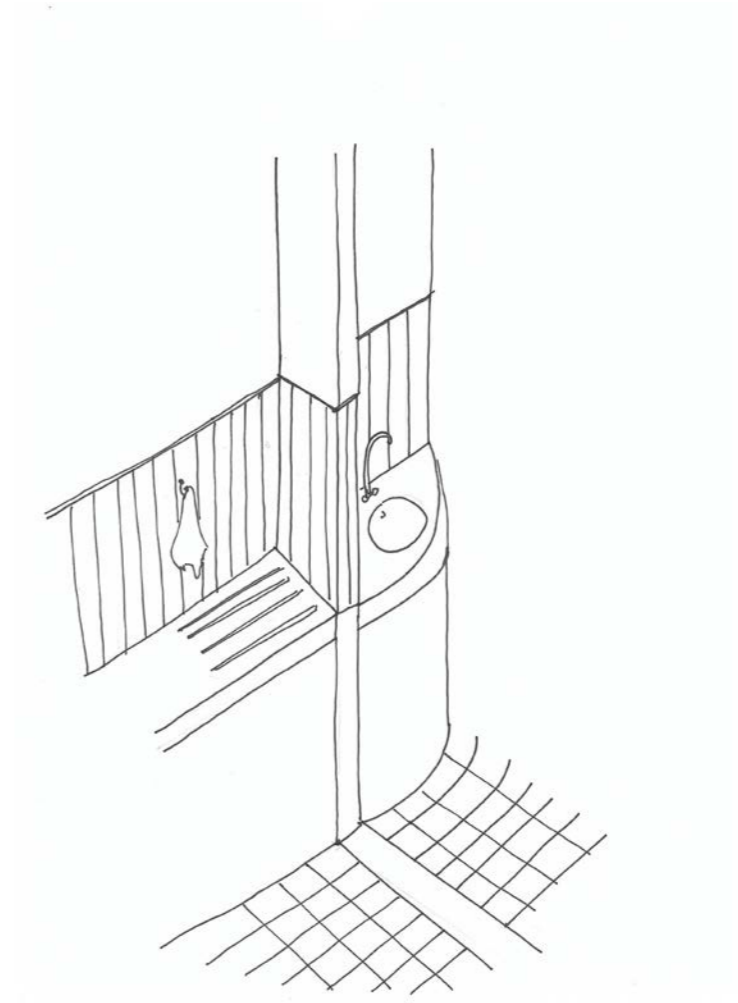
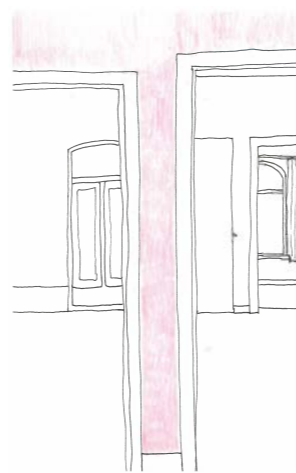
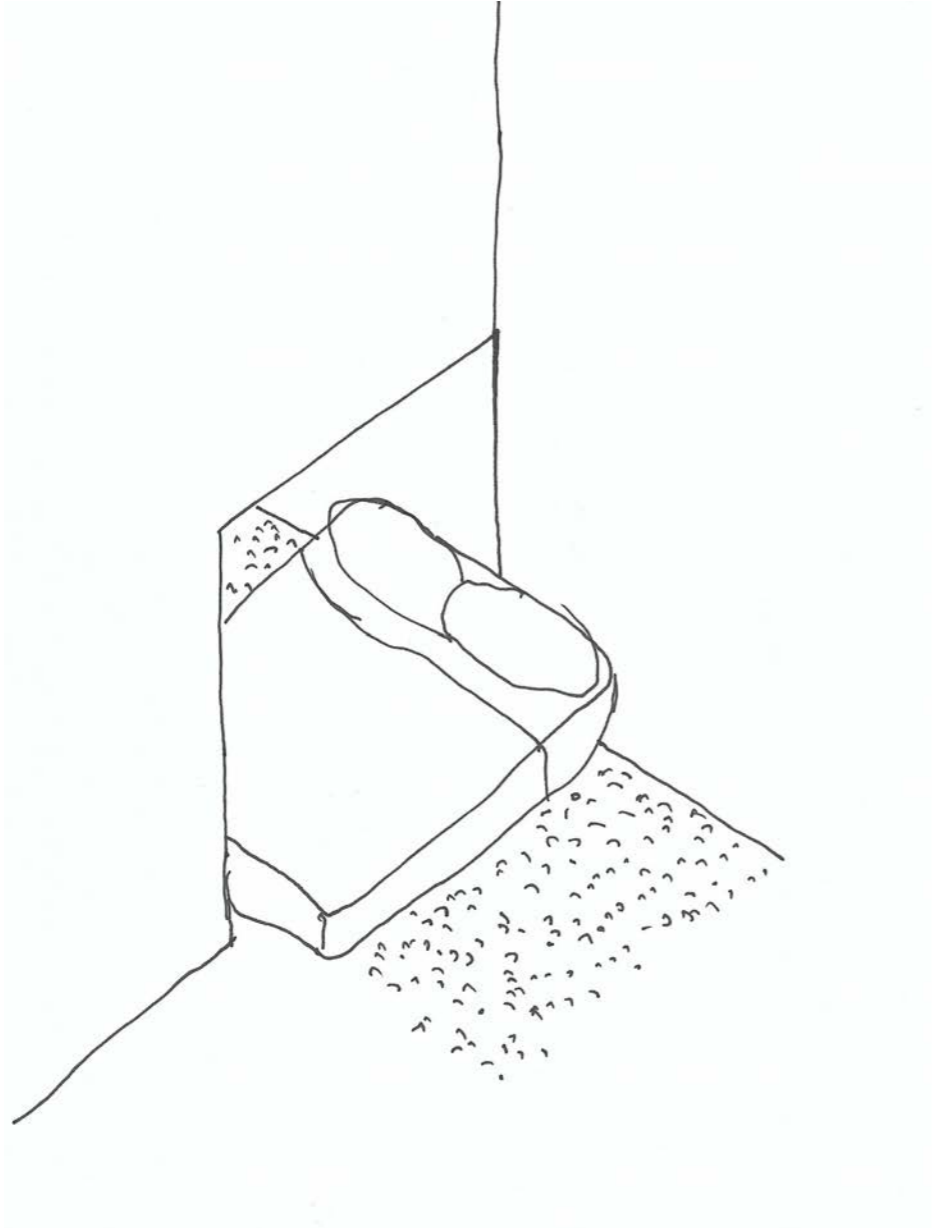

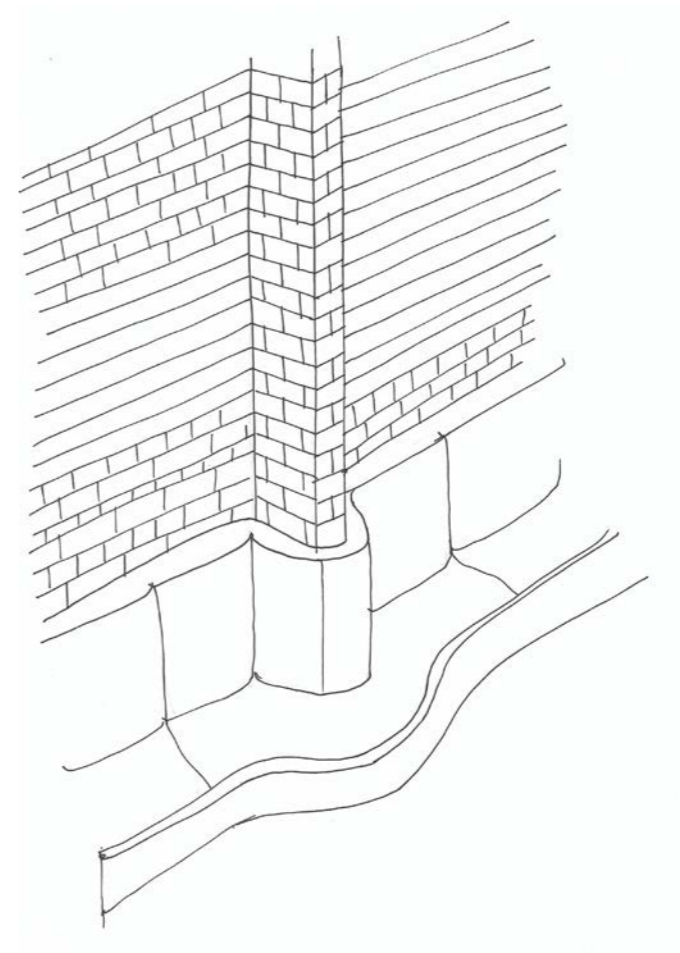
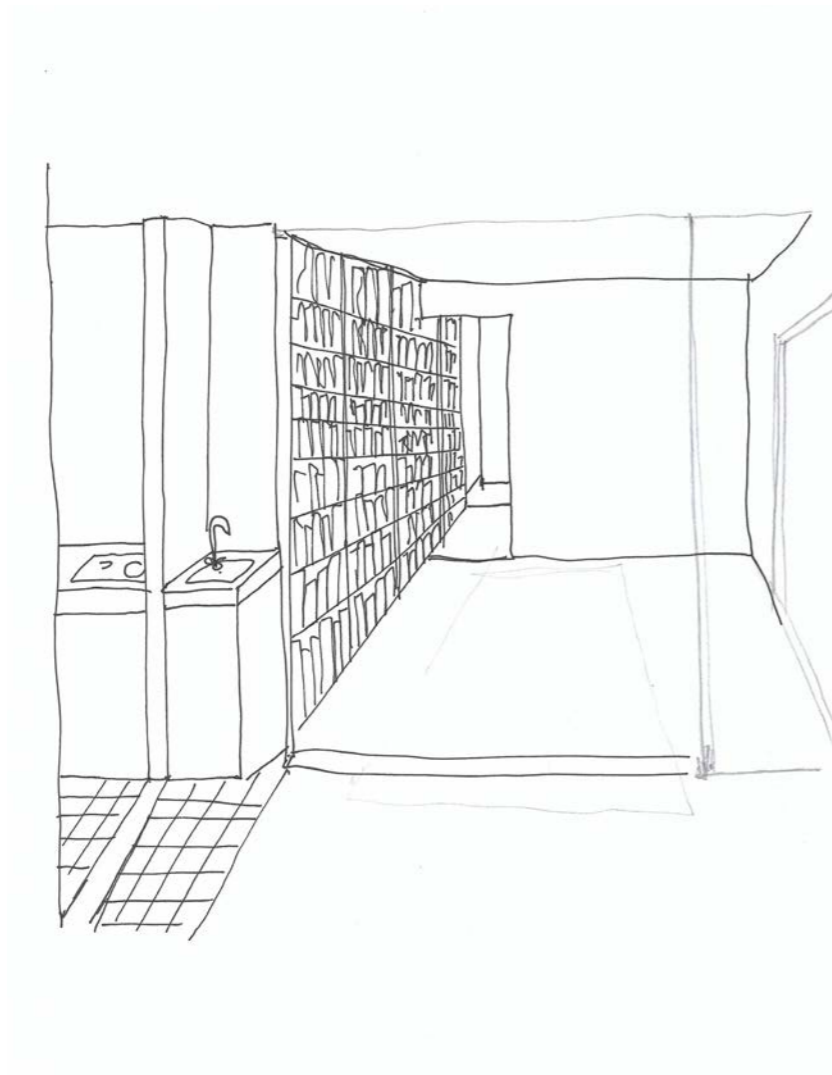



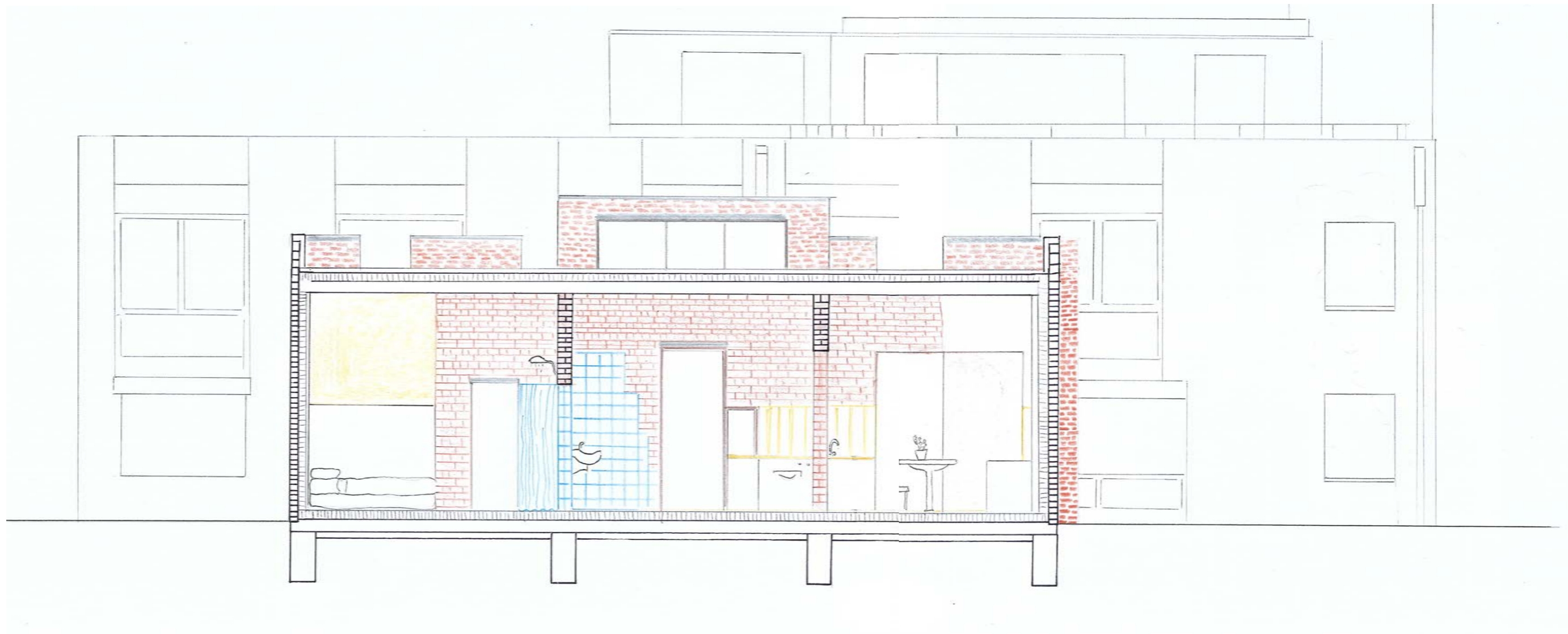

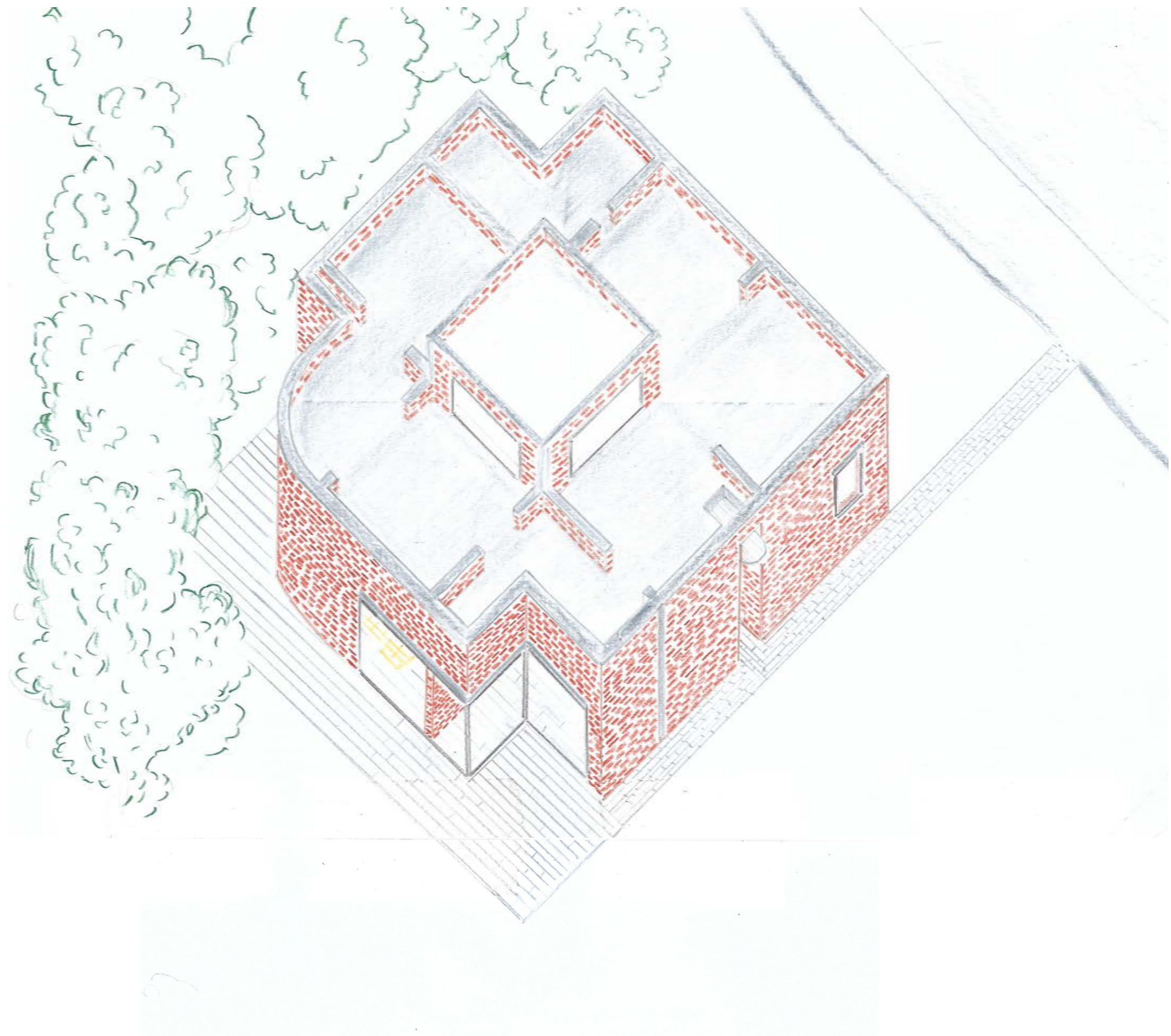

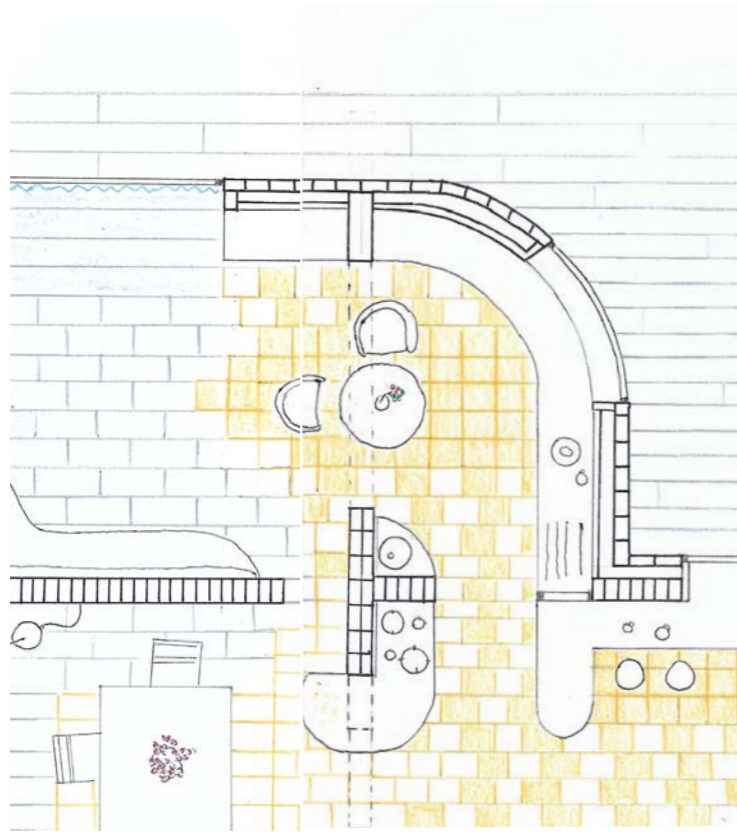

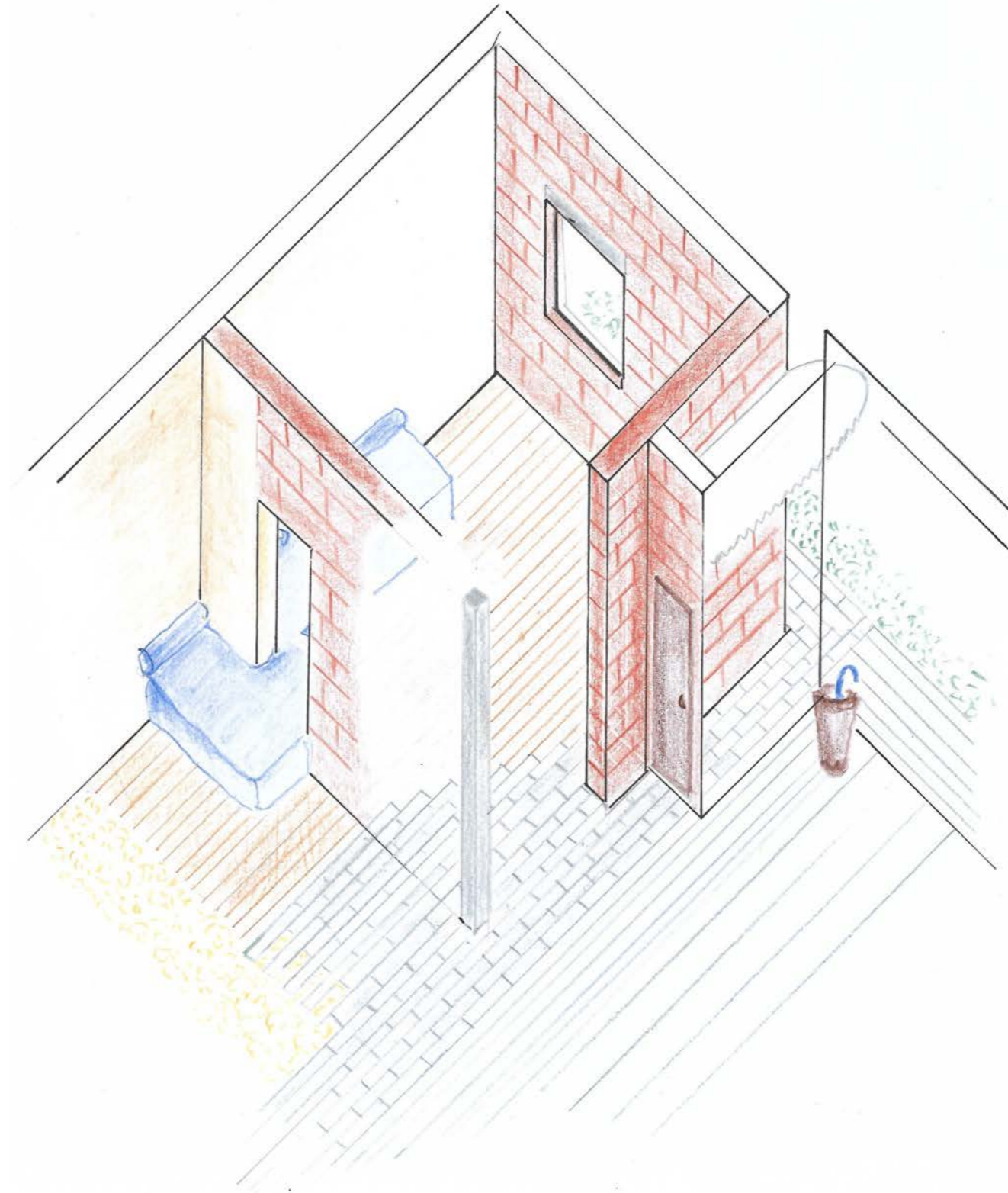
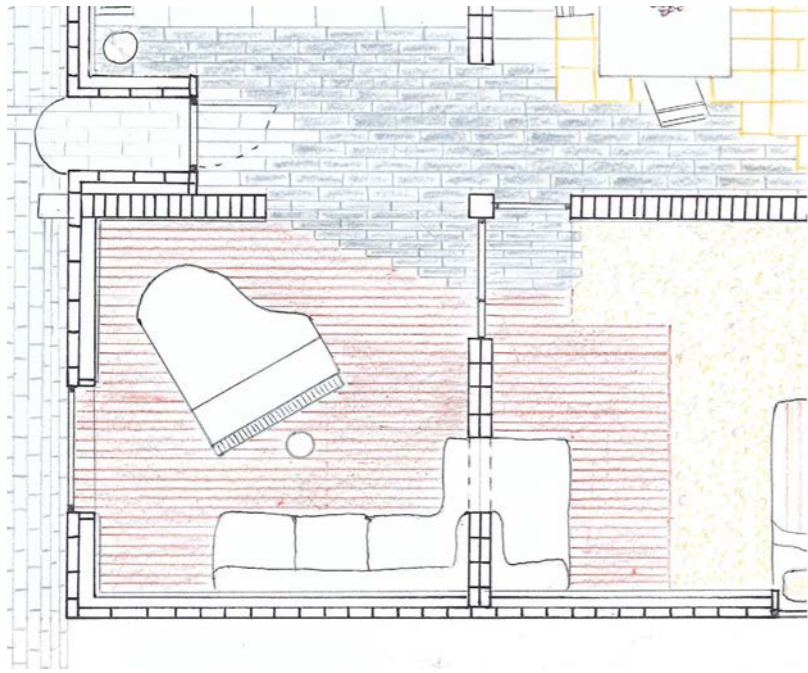

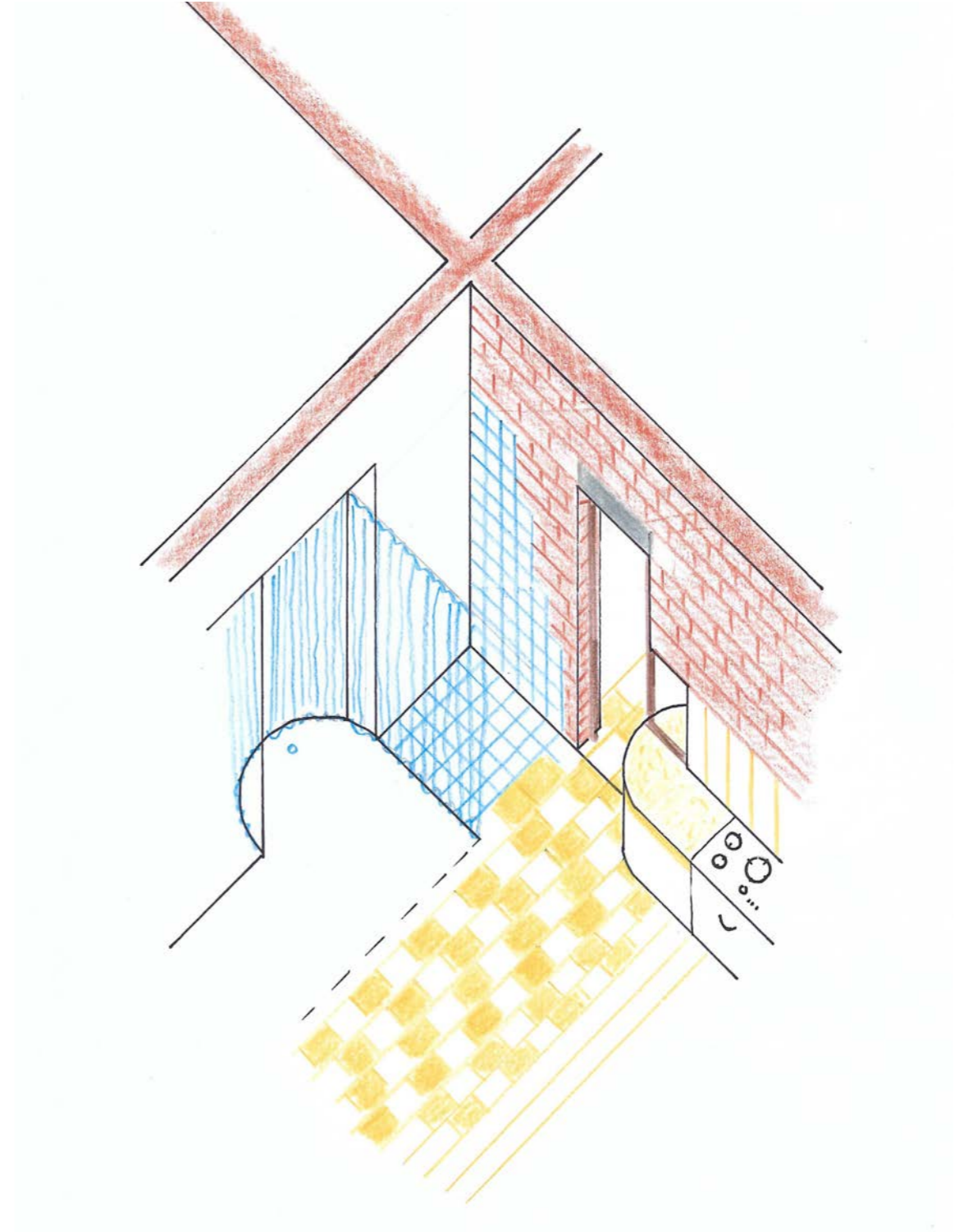

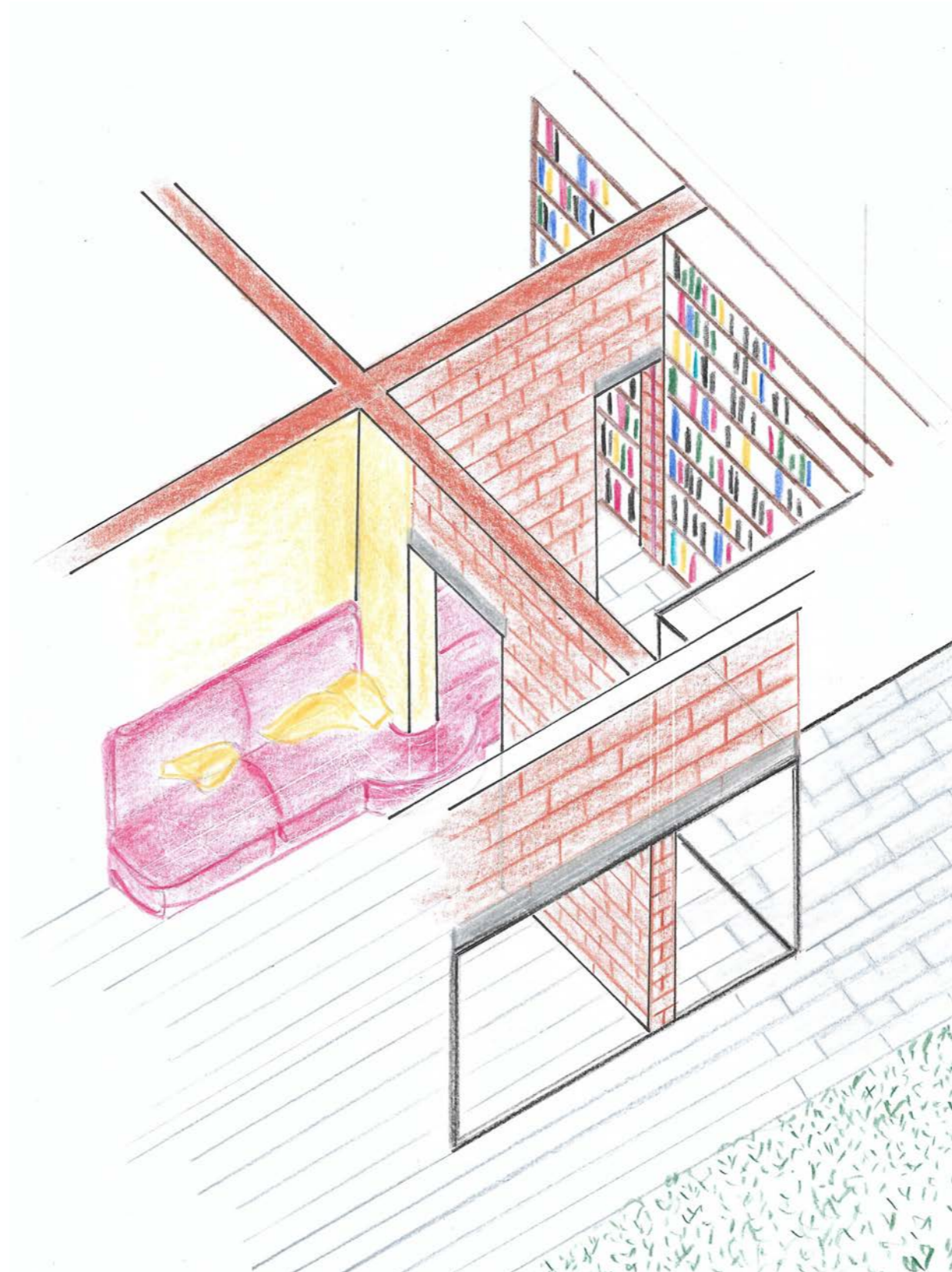
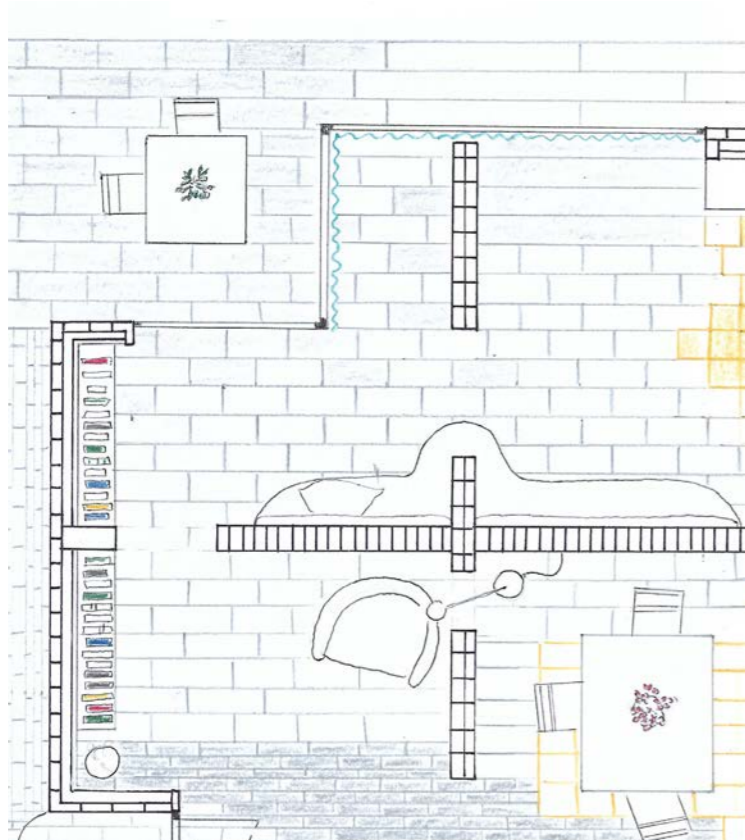

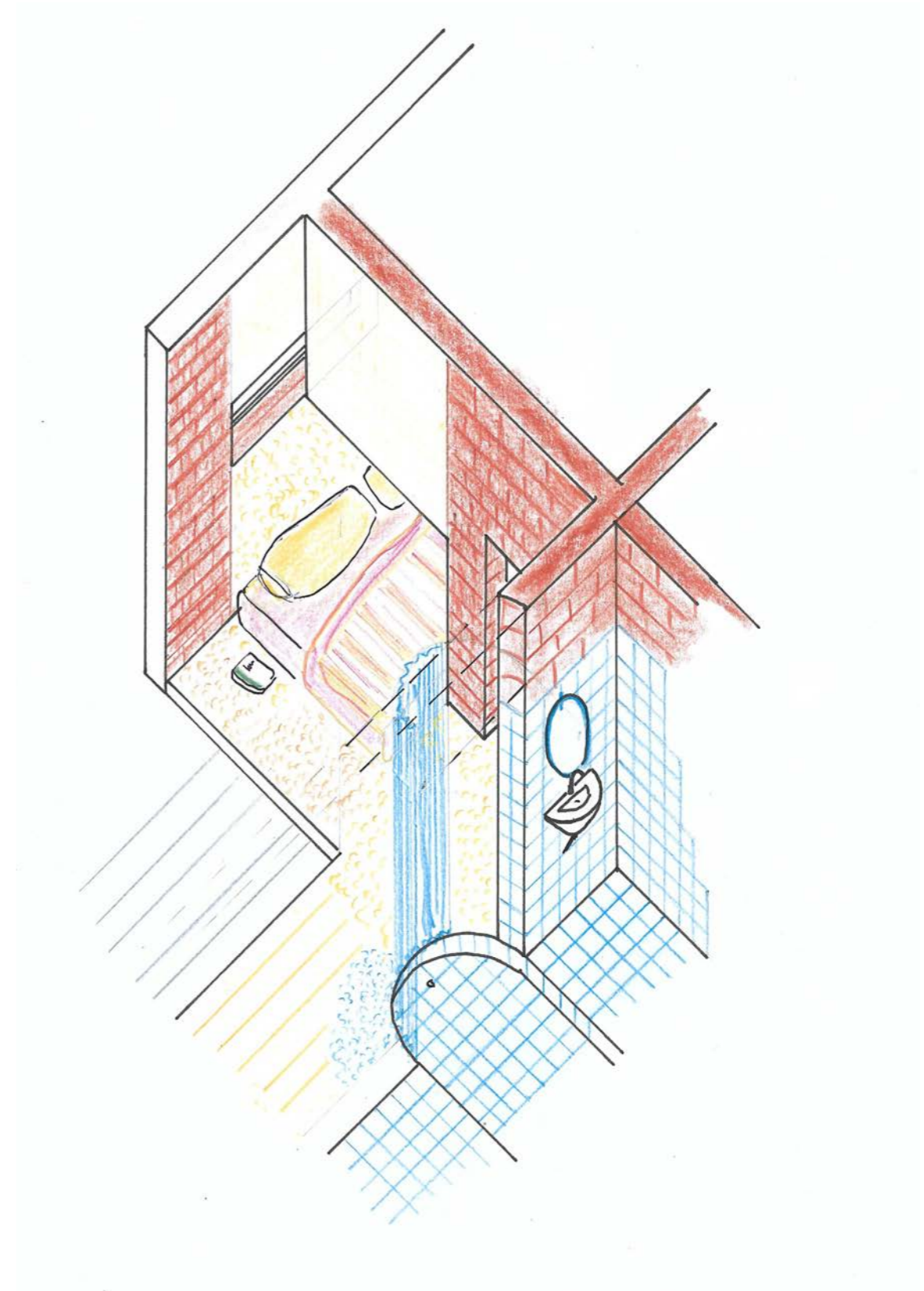
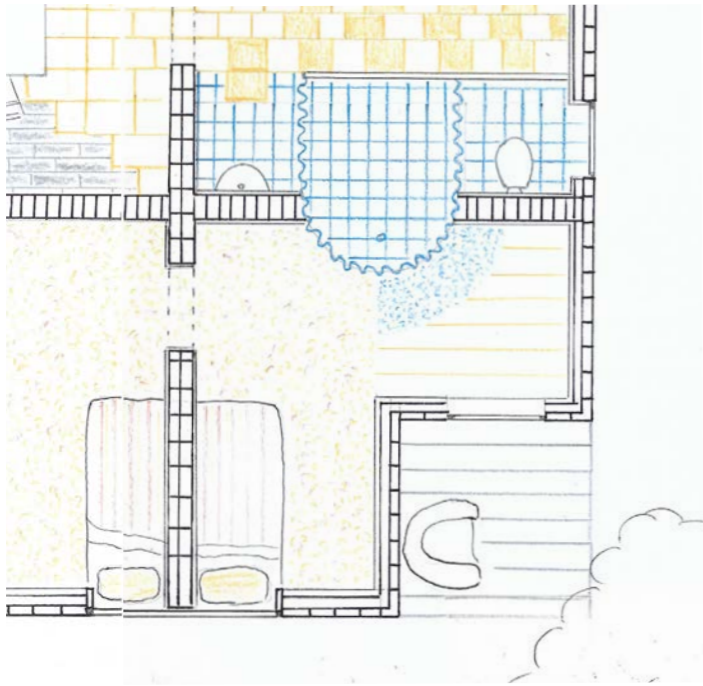

Movement 2

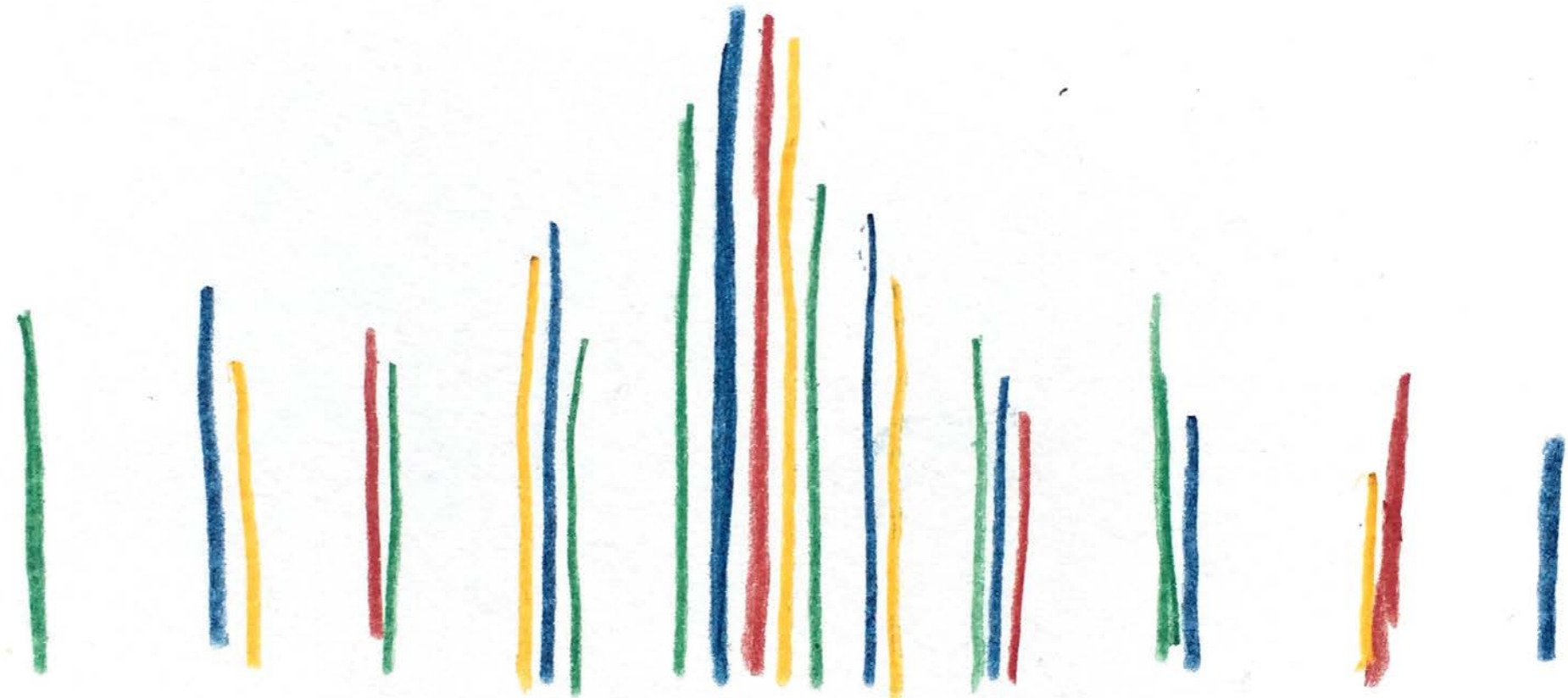

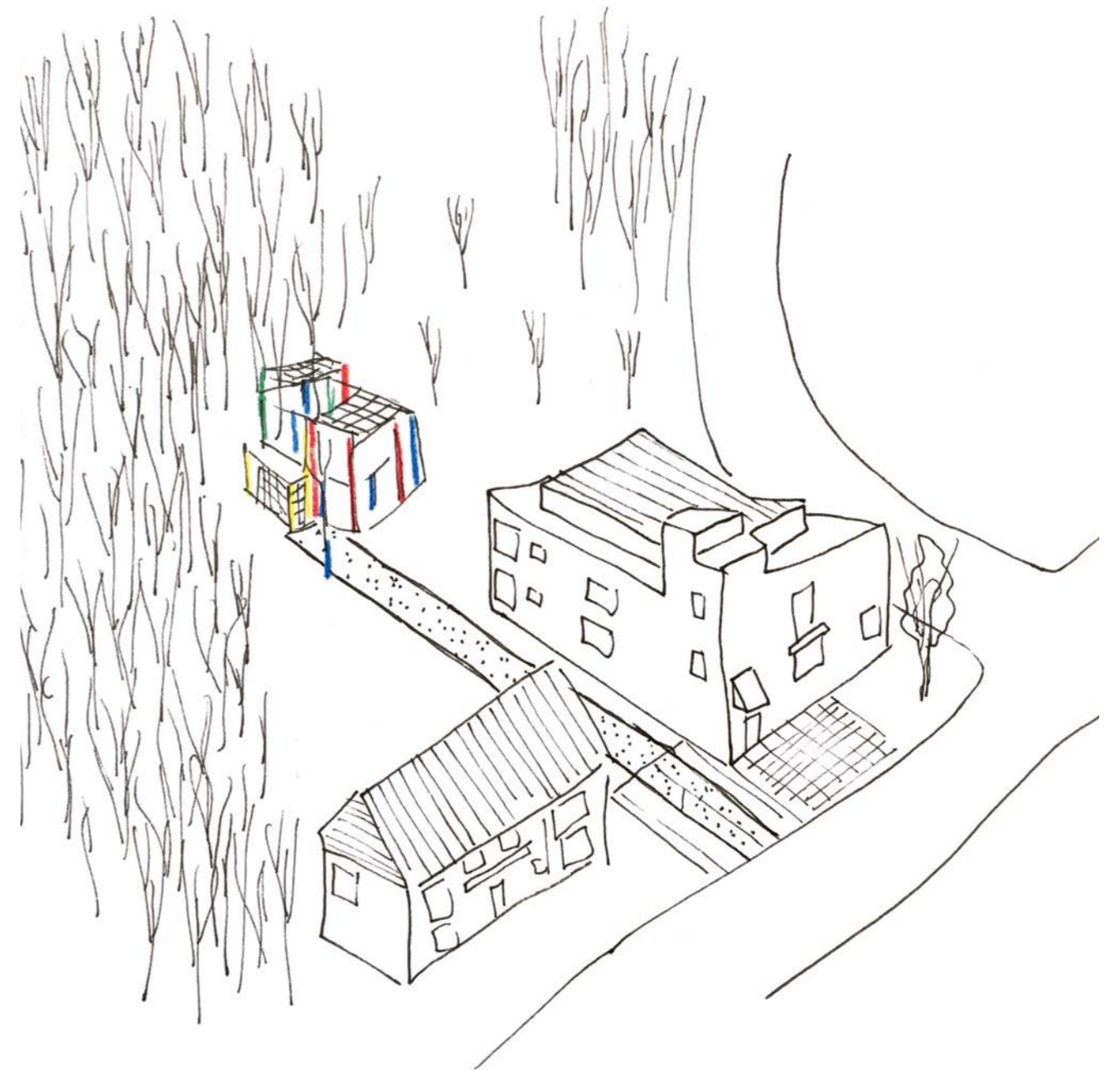
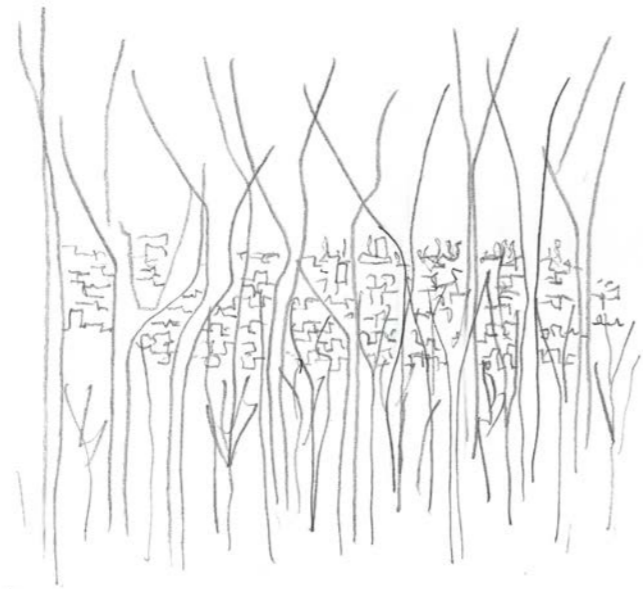

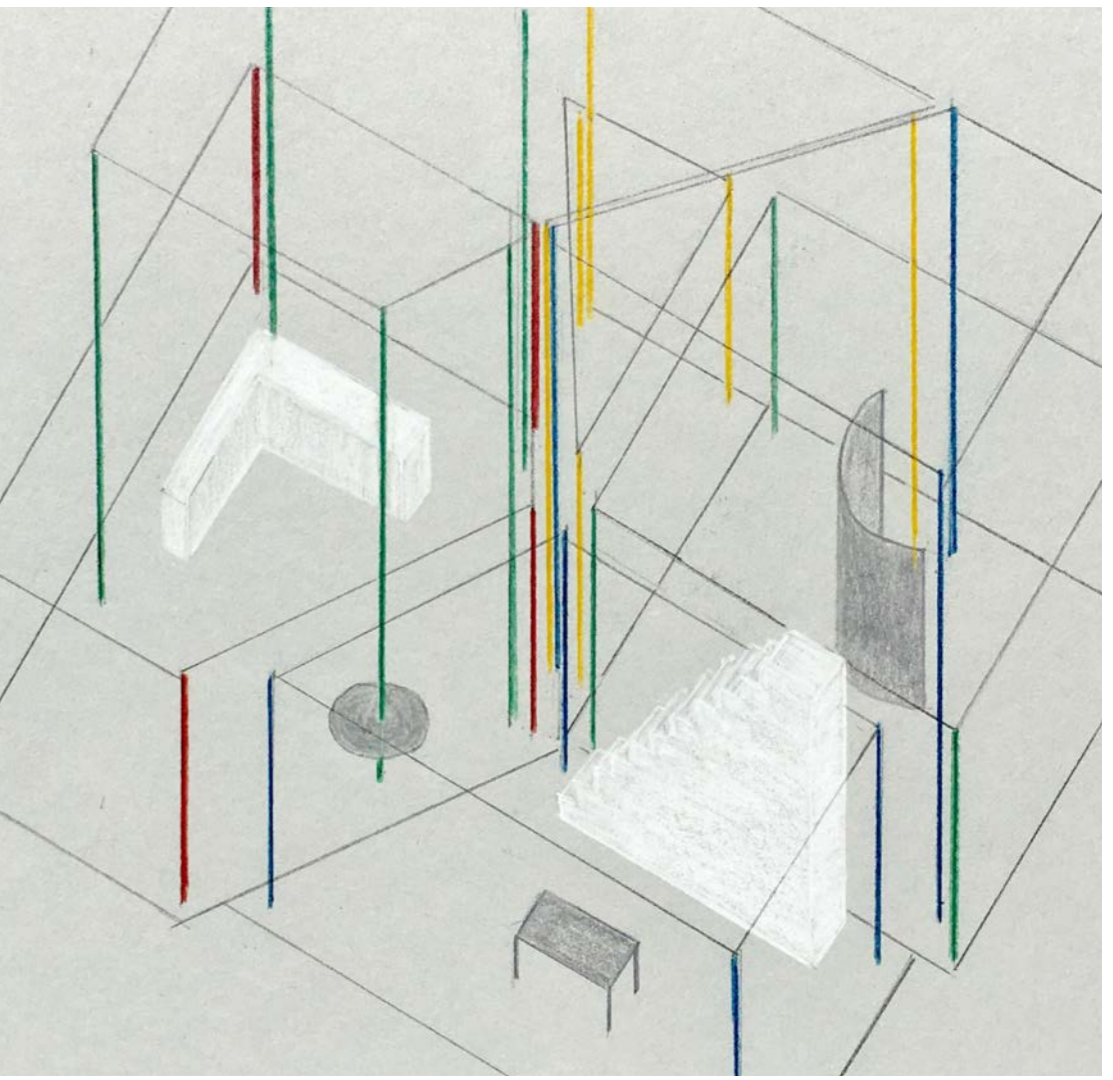
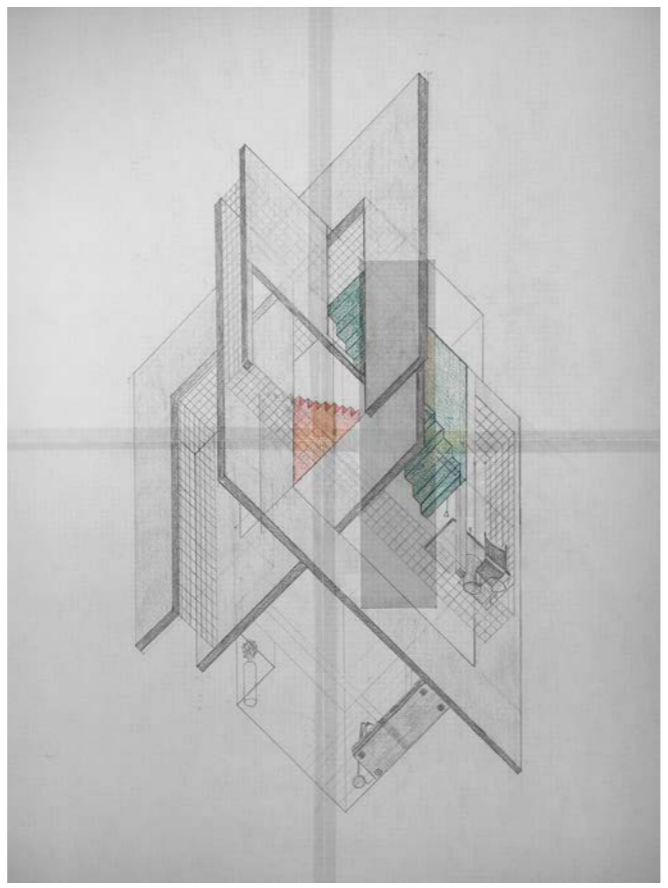
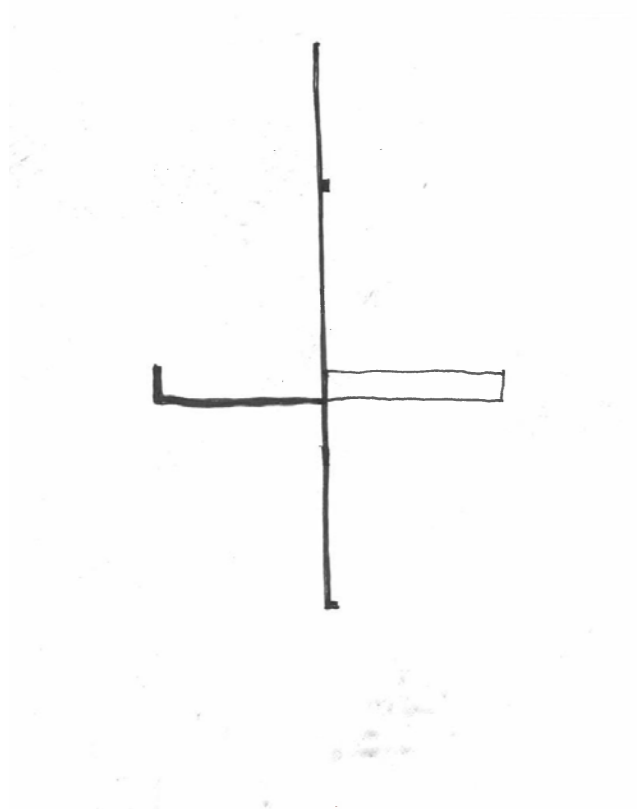

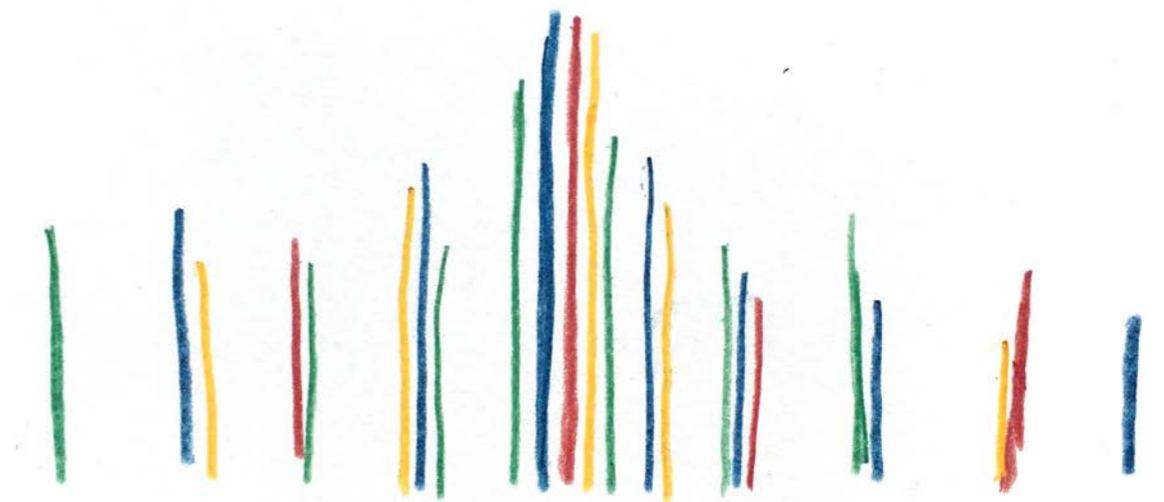

contradictions...

I live alone, but I like company...

I love music but i seek the
silence of the forest...

I enjoy the whole,
but I prefer the moments..

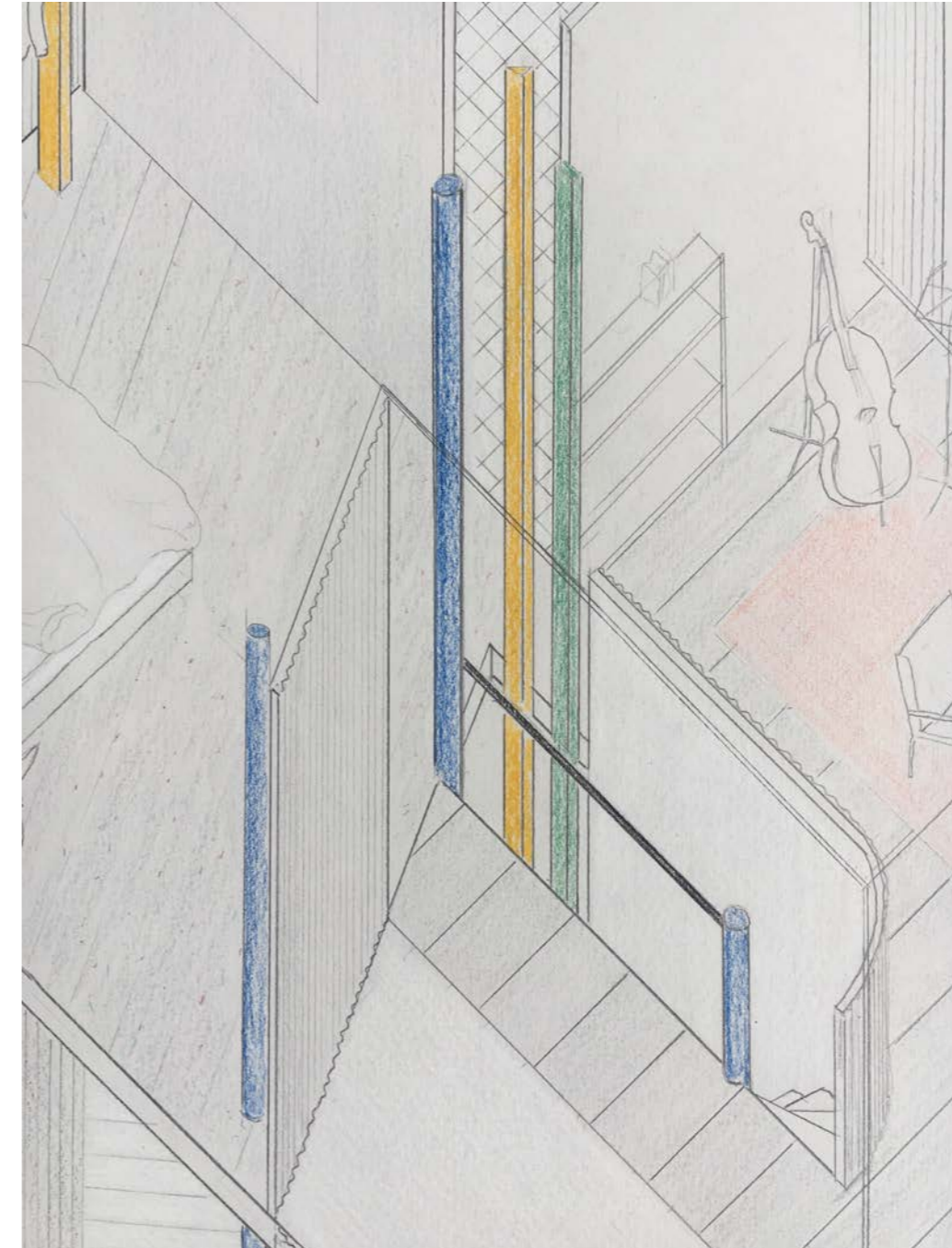

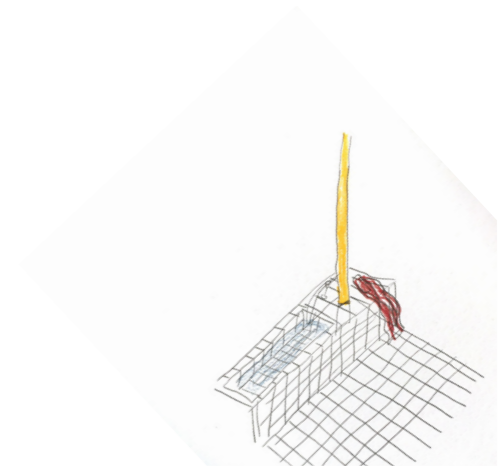
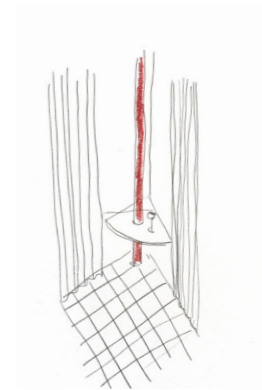
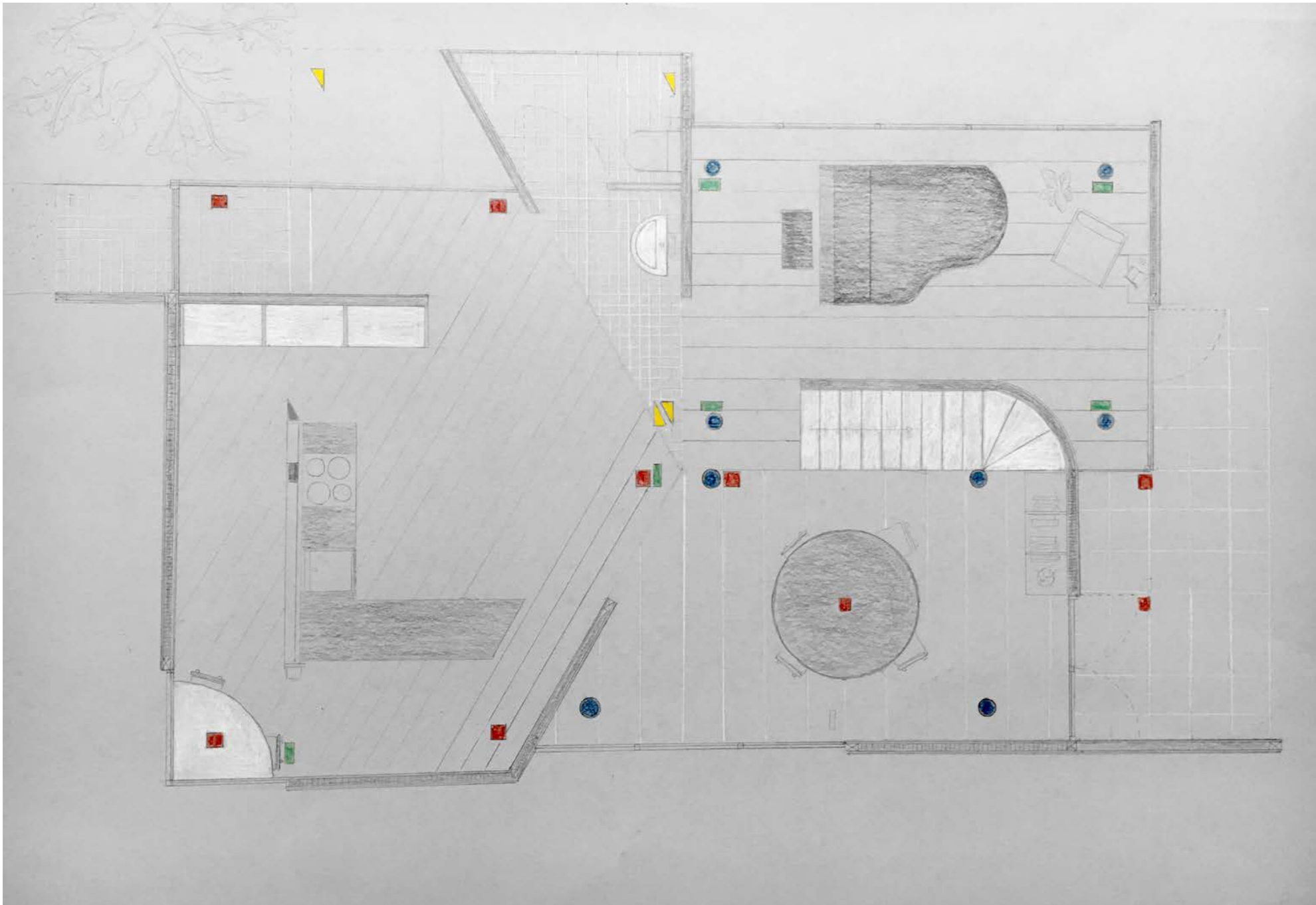

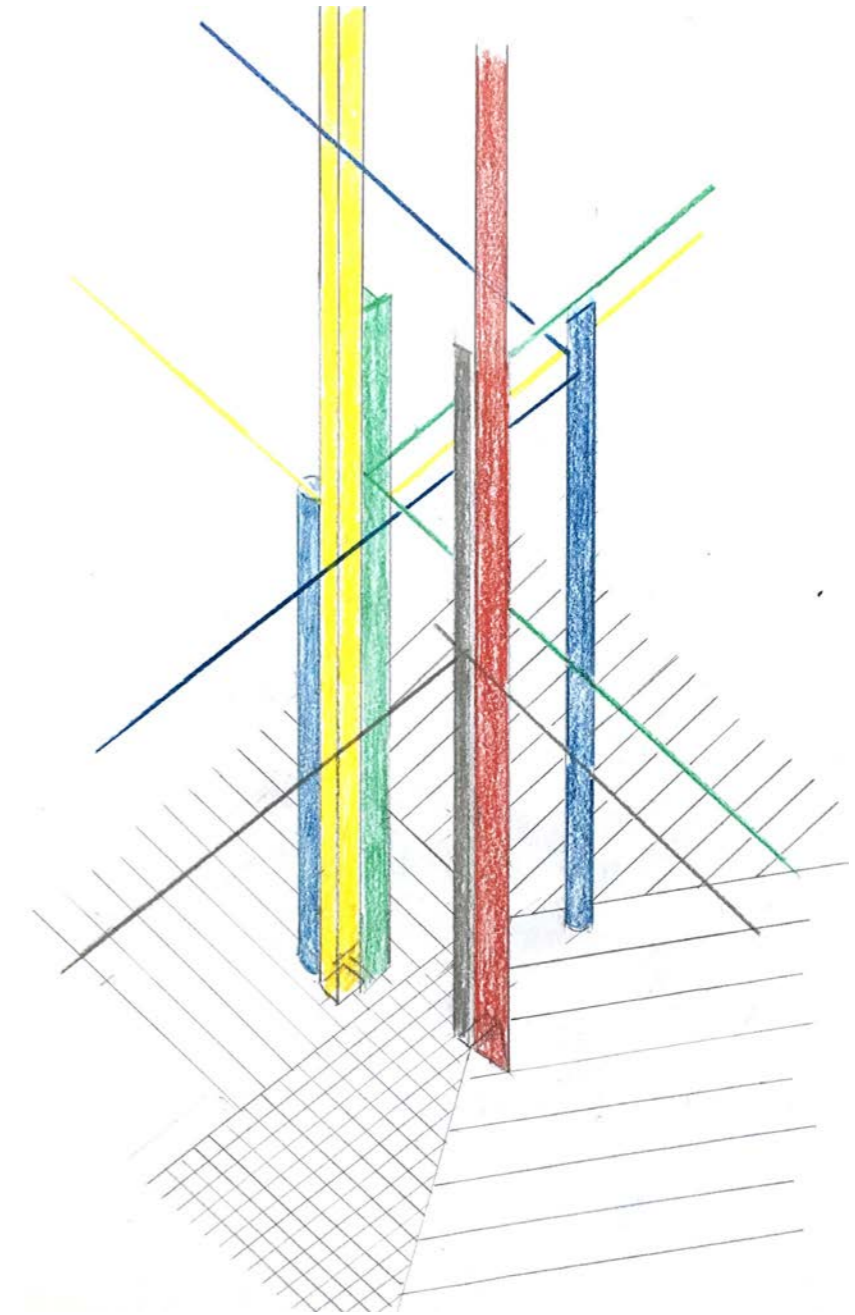
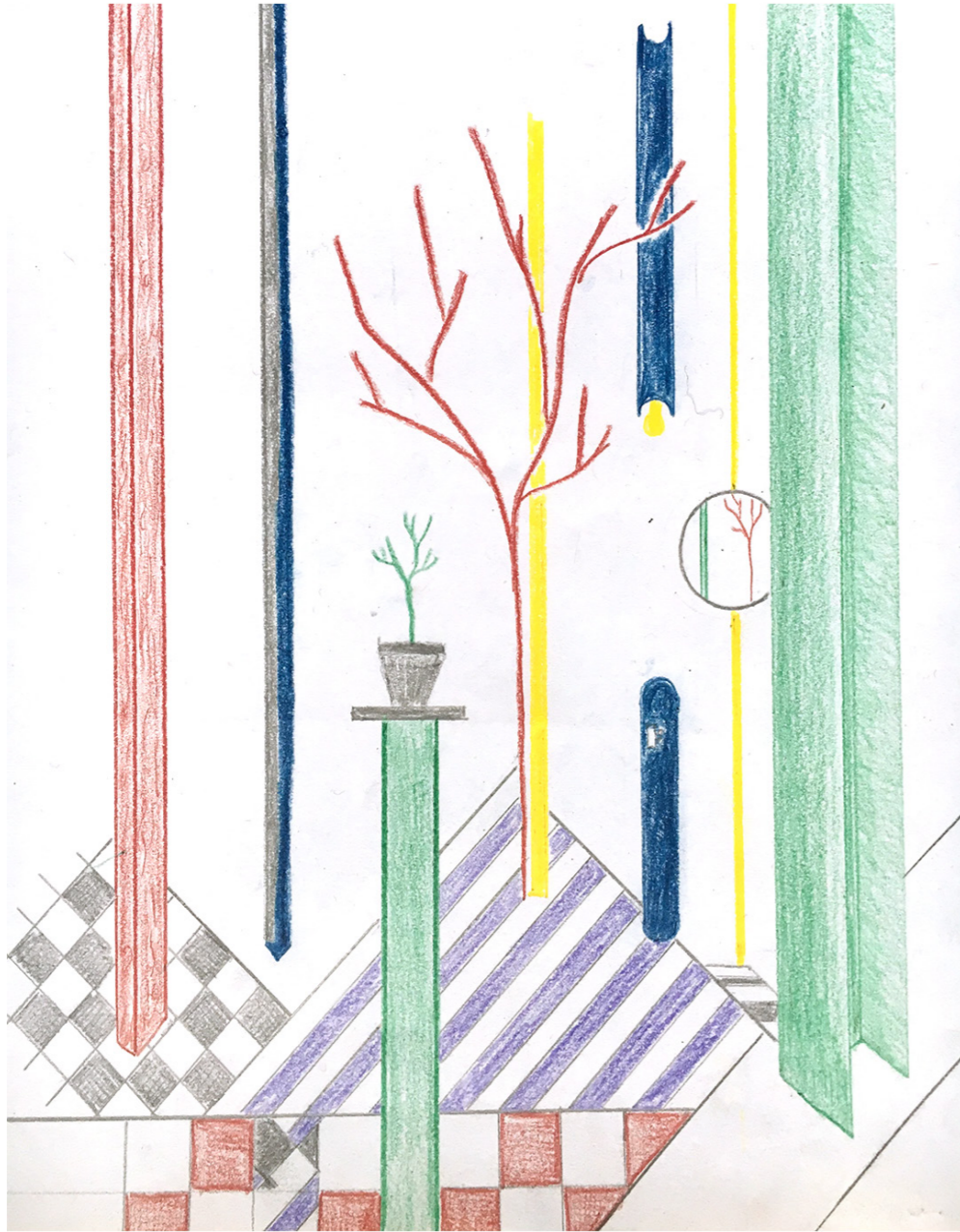

house for a musician

I knew where the grammophon belongs.
If I had to paint music in the afternoon, I would paint it blue.
If I had to paint Per Gynt in the morning, I would paint it green.
The grammophon belongs in the center.

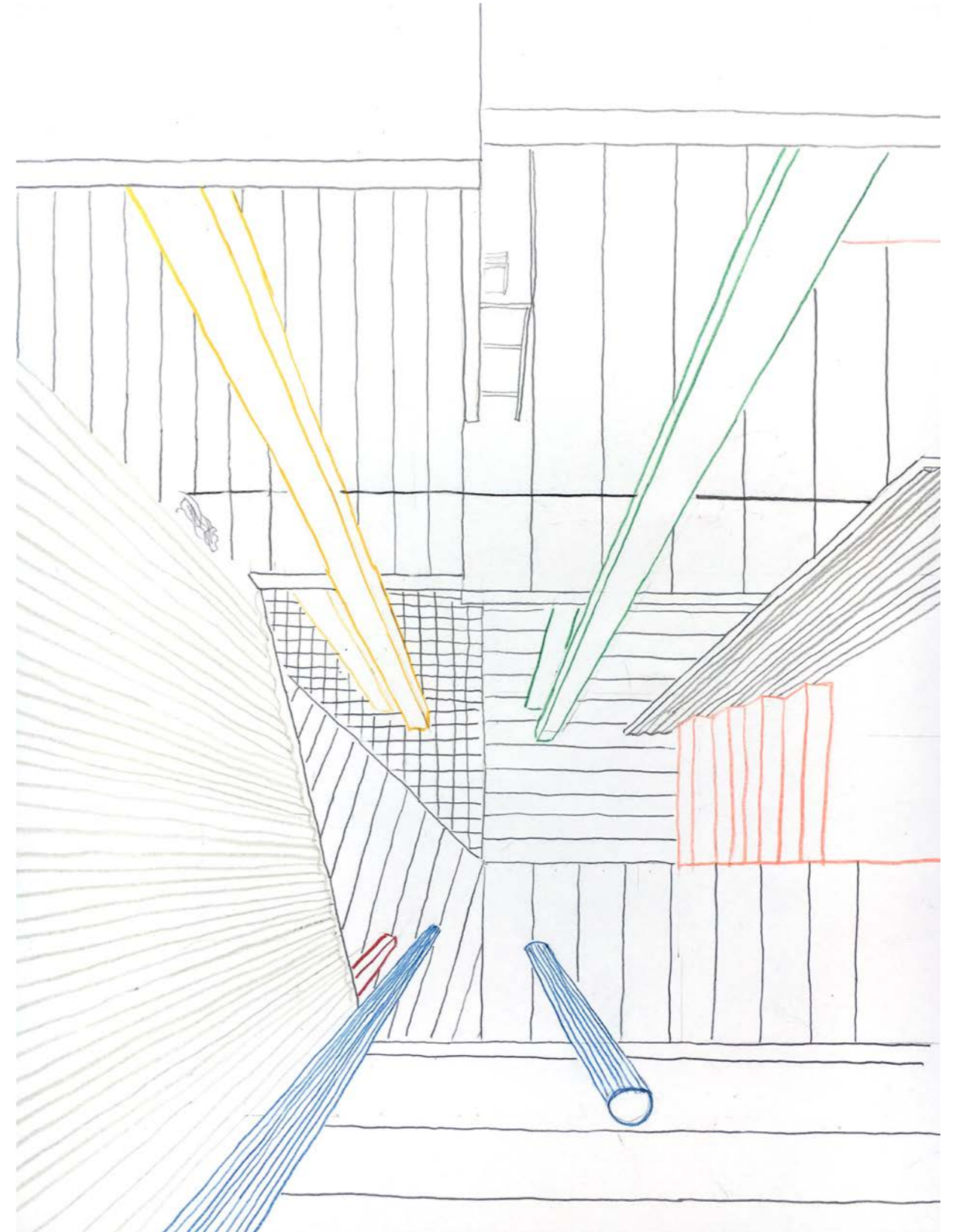
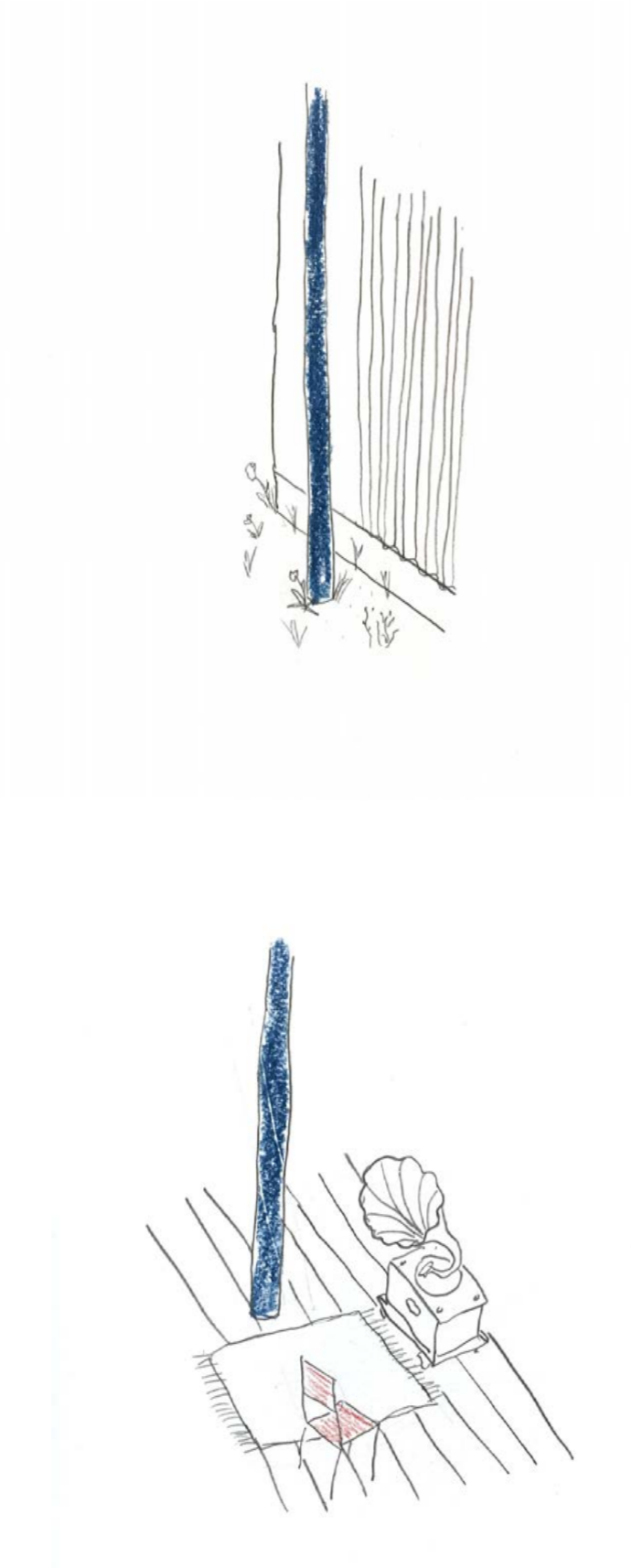

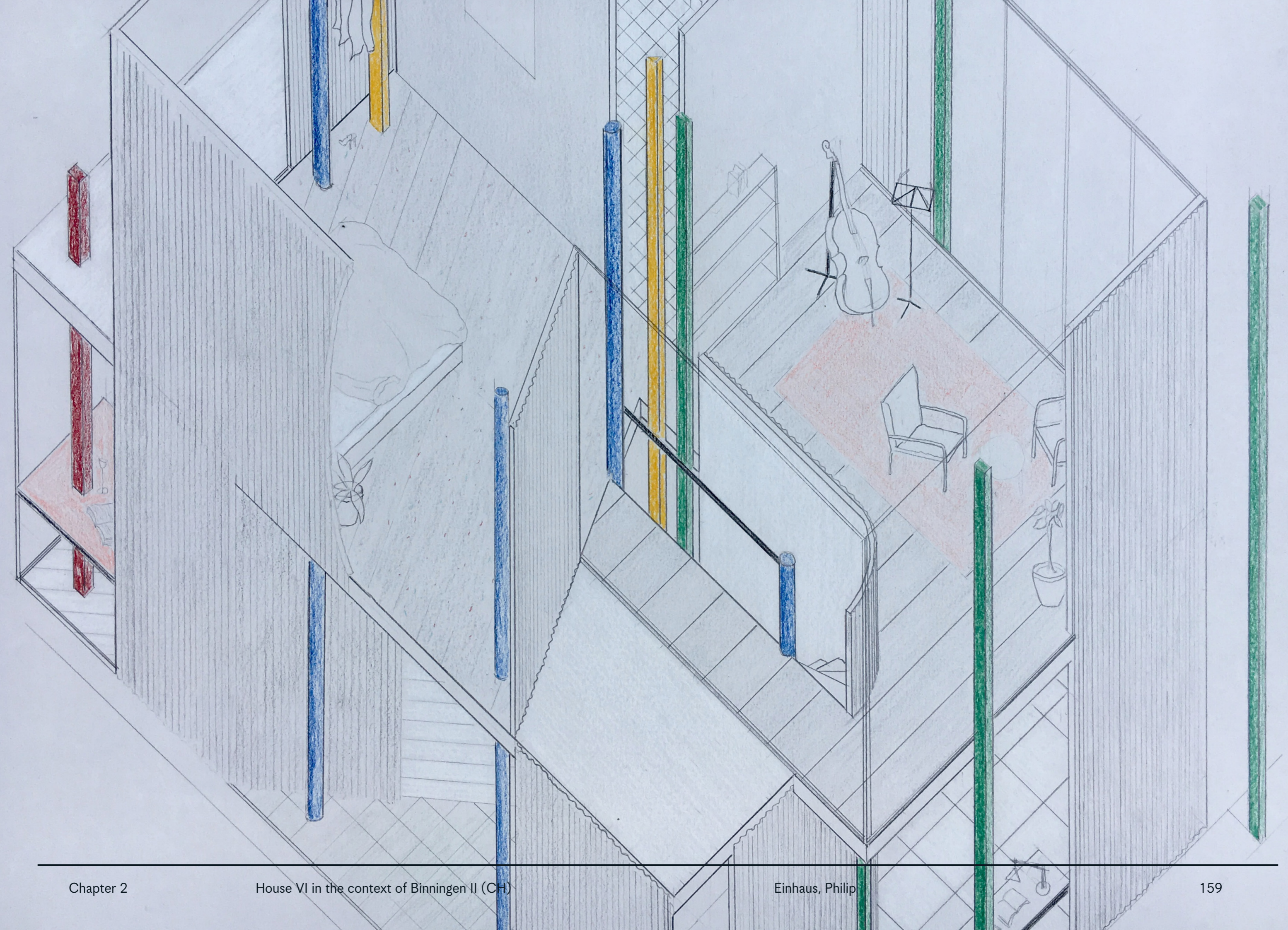

contradictions...

I need order, but sometimes I
enjoy distraction..

I am adaptive, but I like to take
over...

I like red, but not without
green...

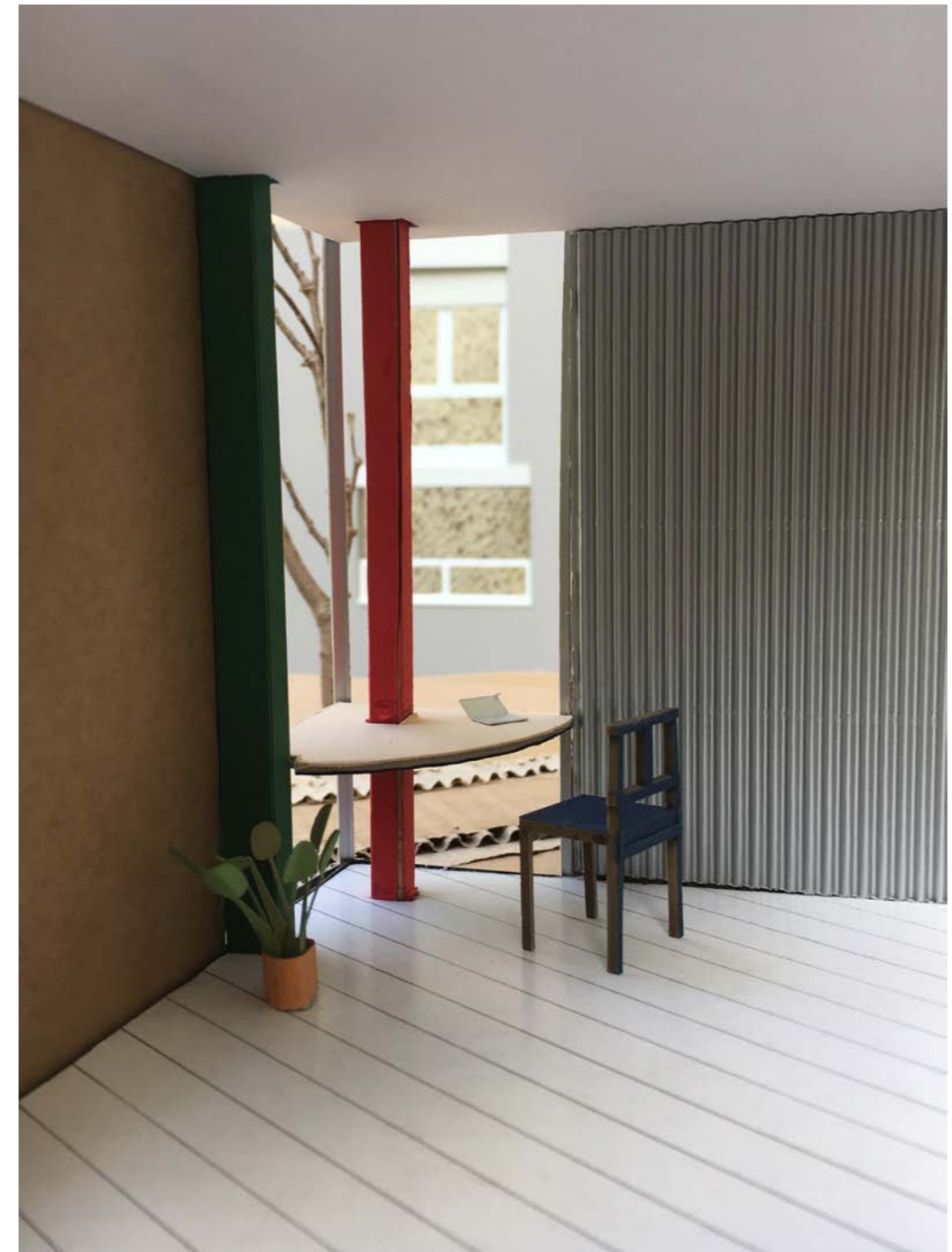
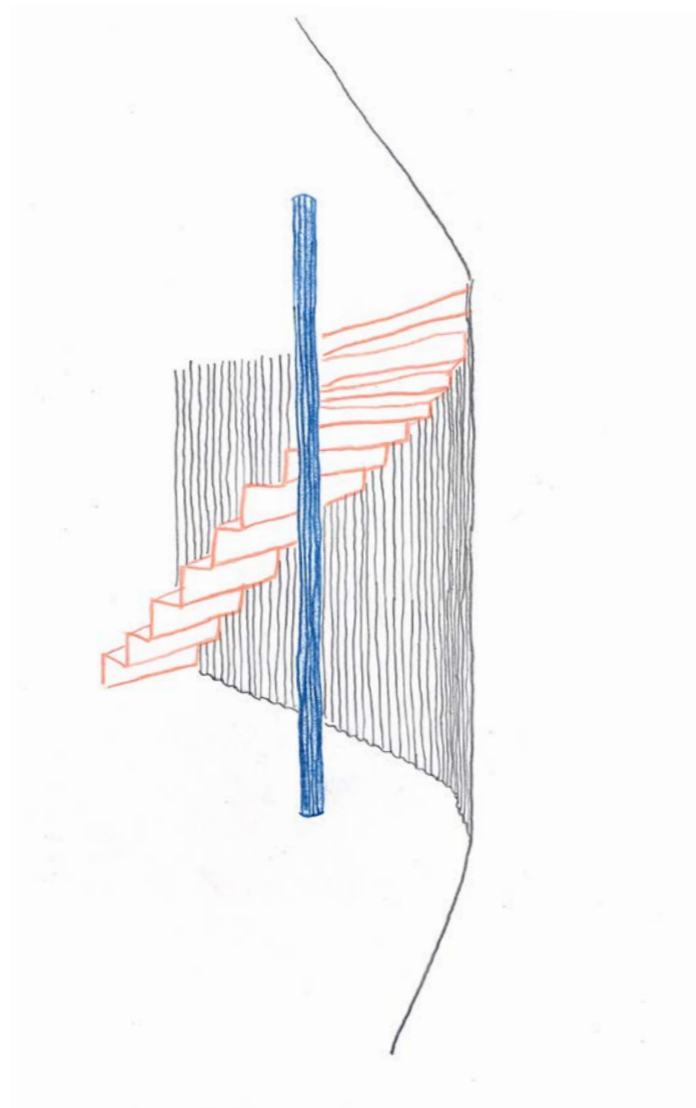

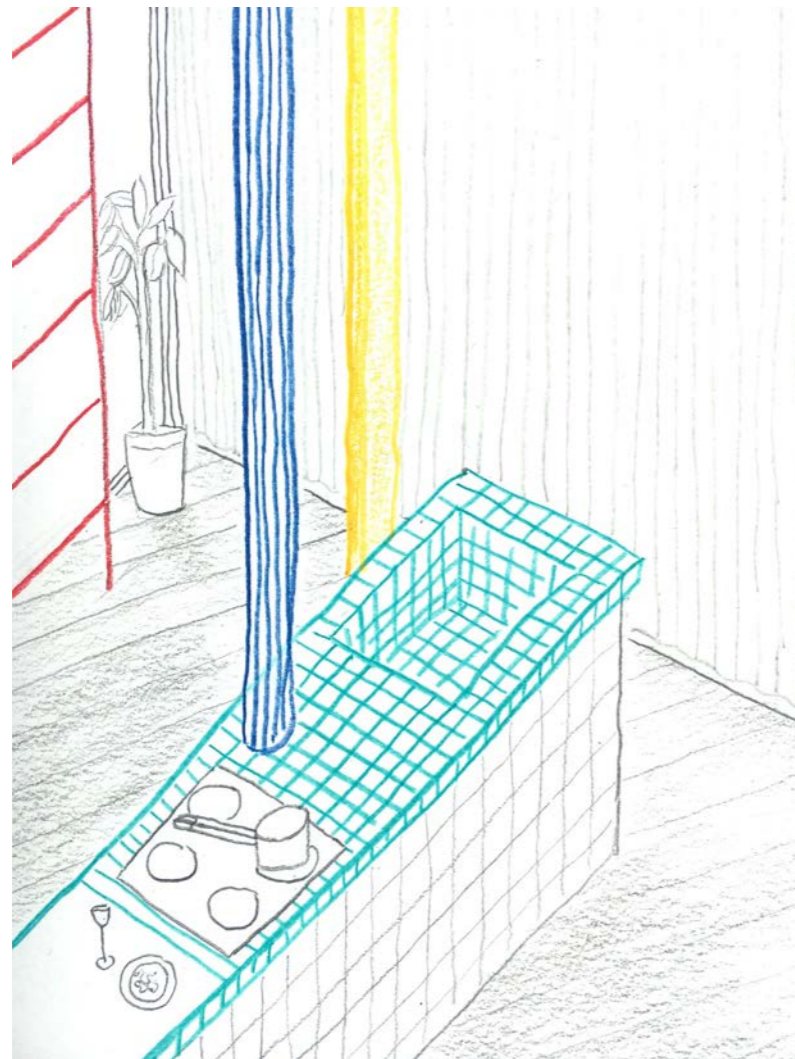

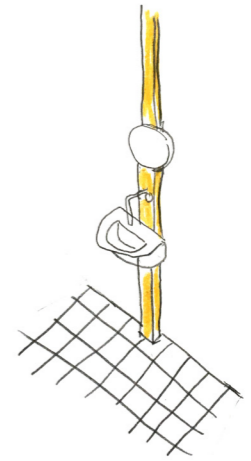
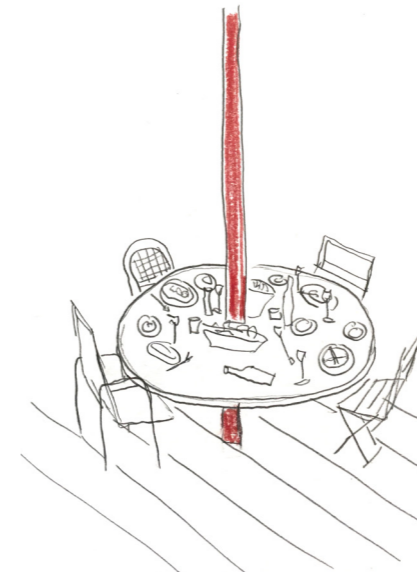
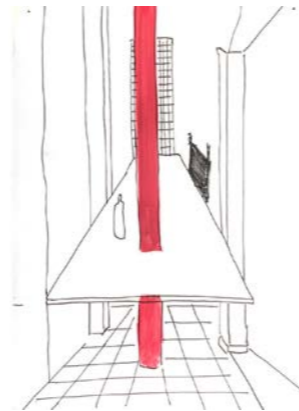

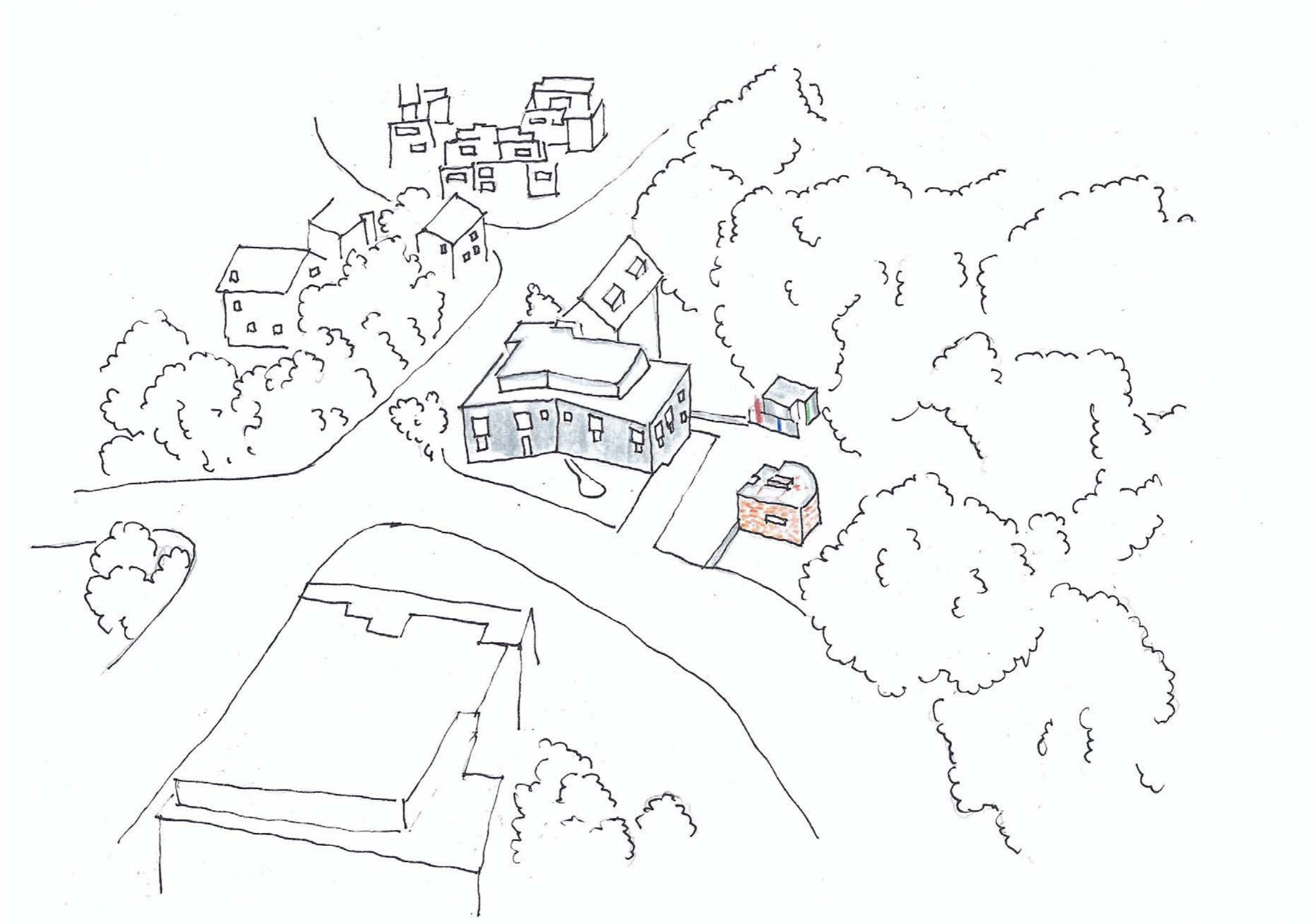

Movement 2

Belgium

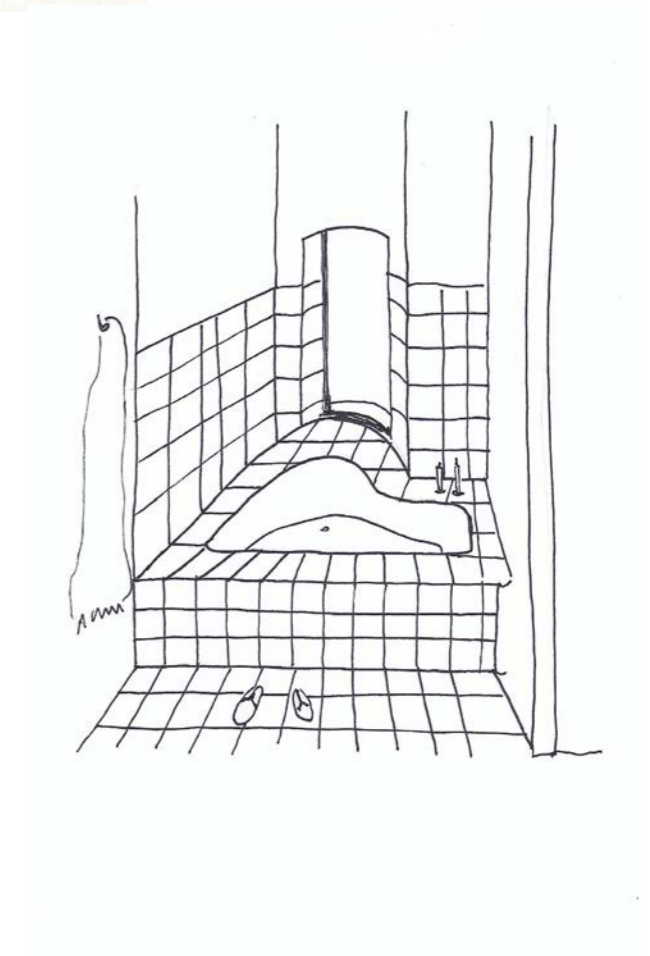
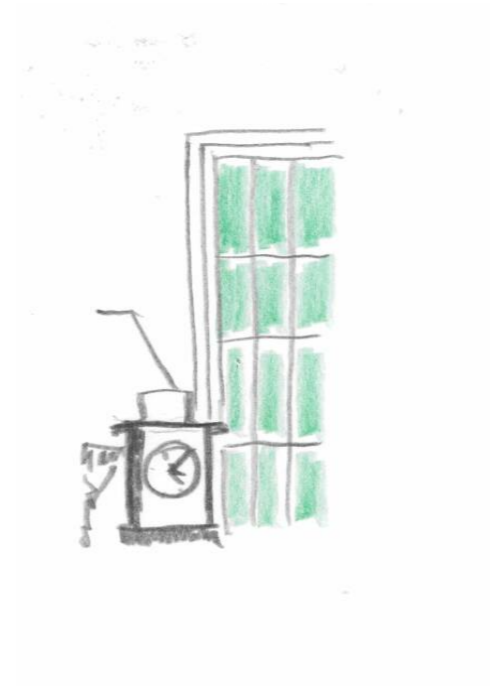
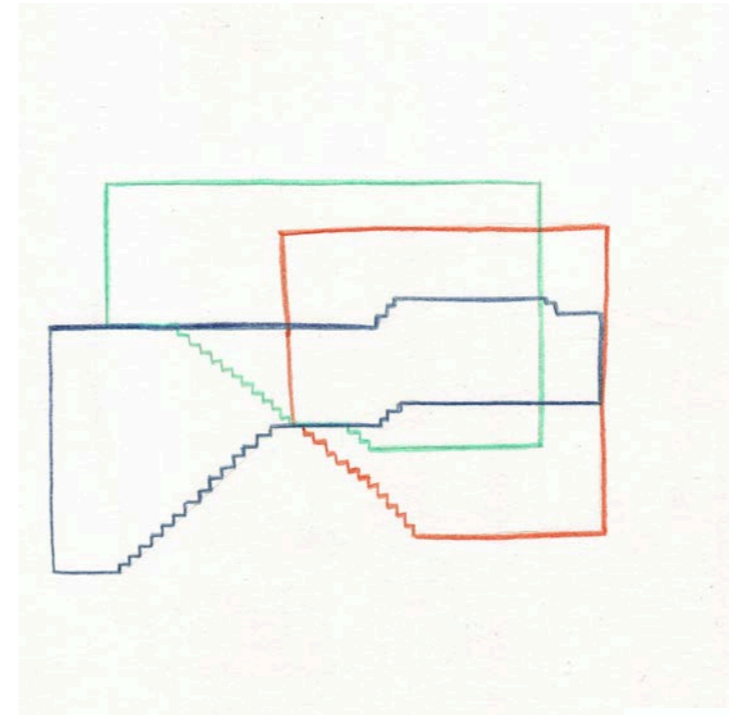

Movement 2

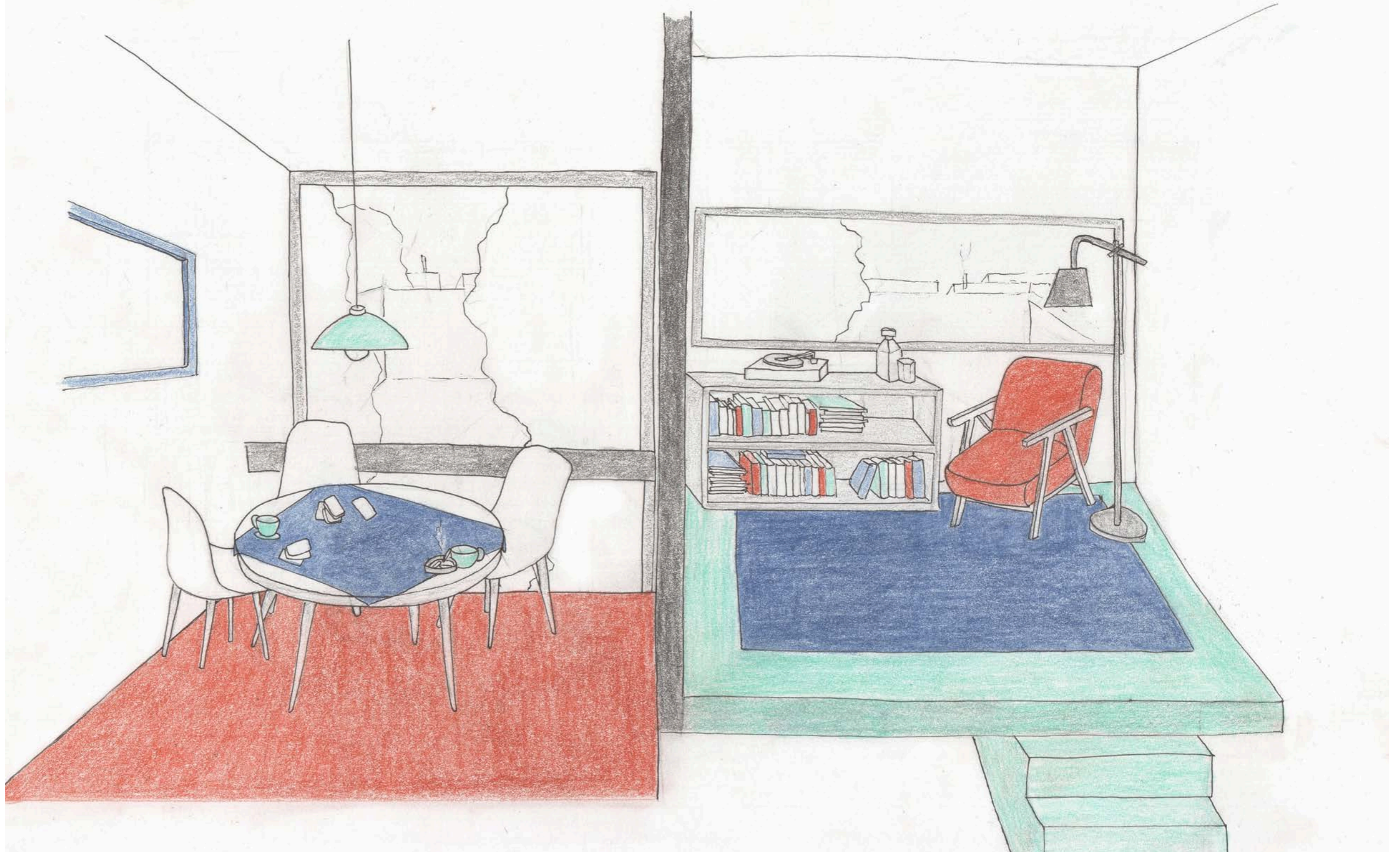



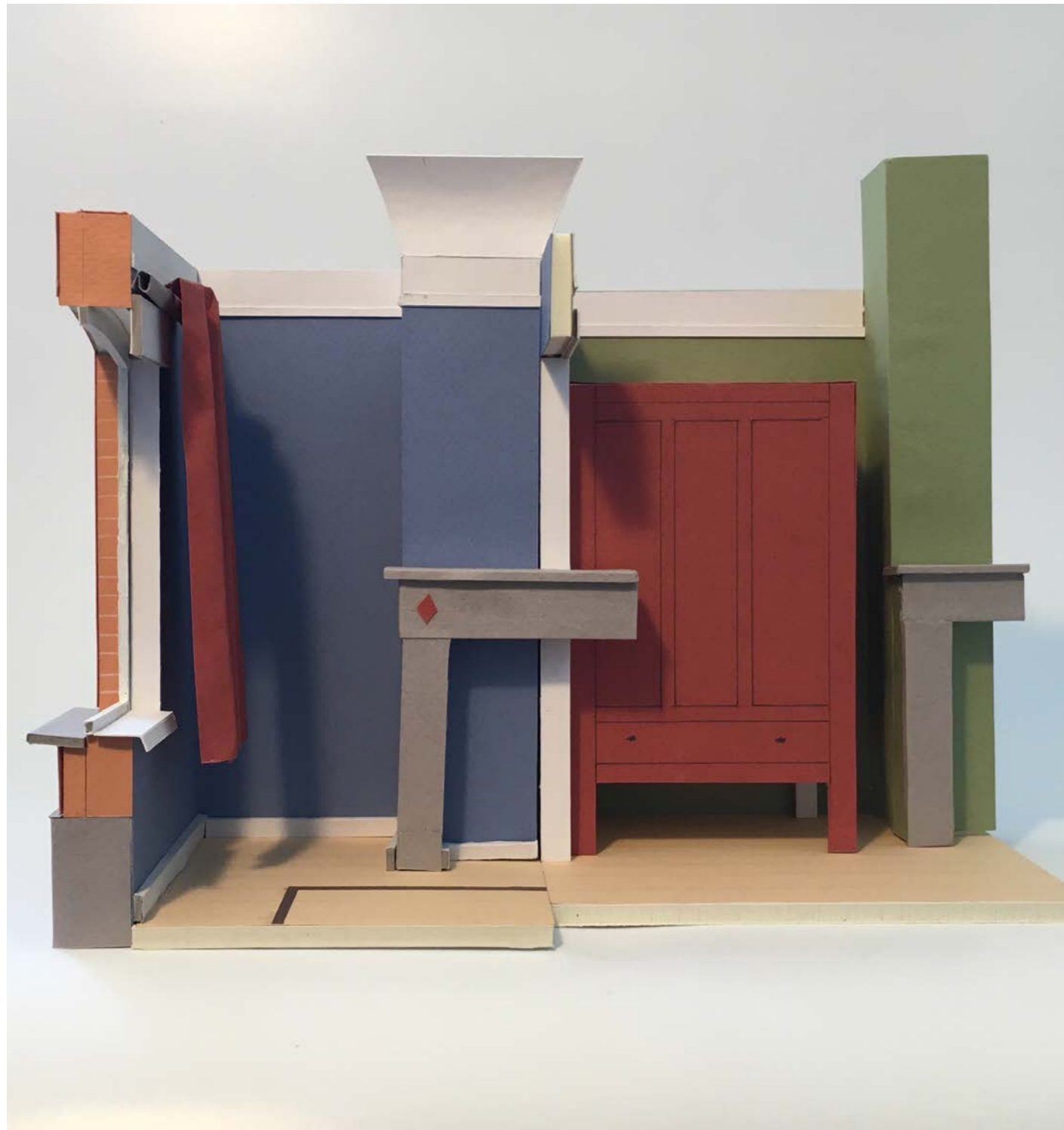

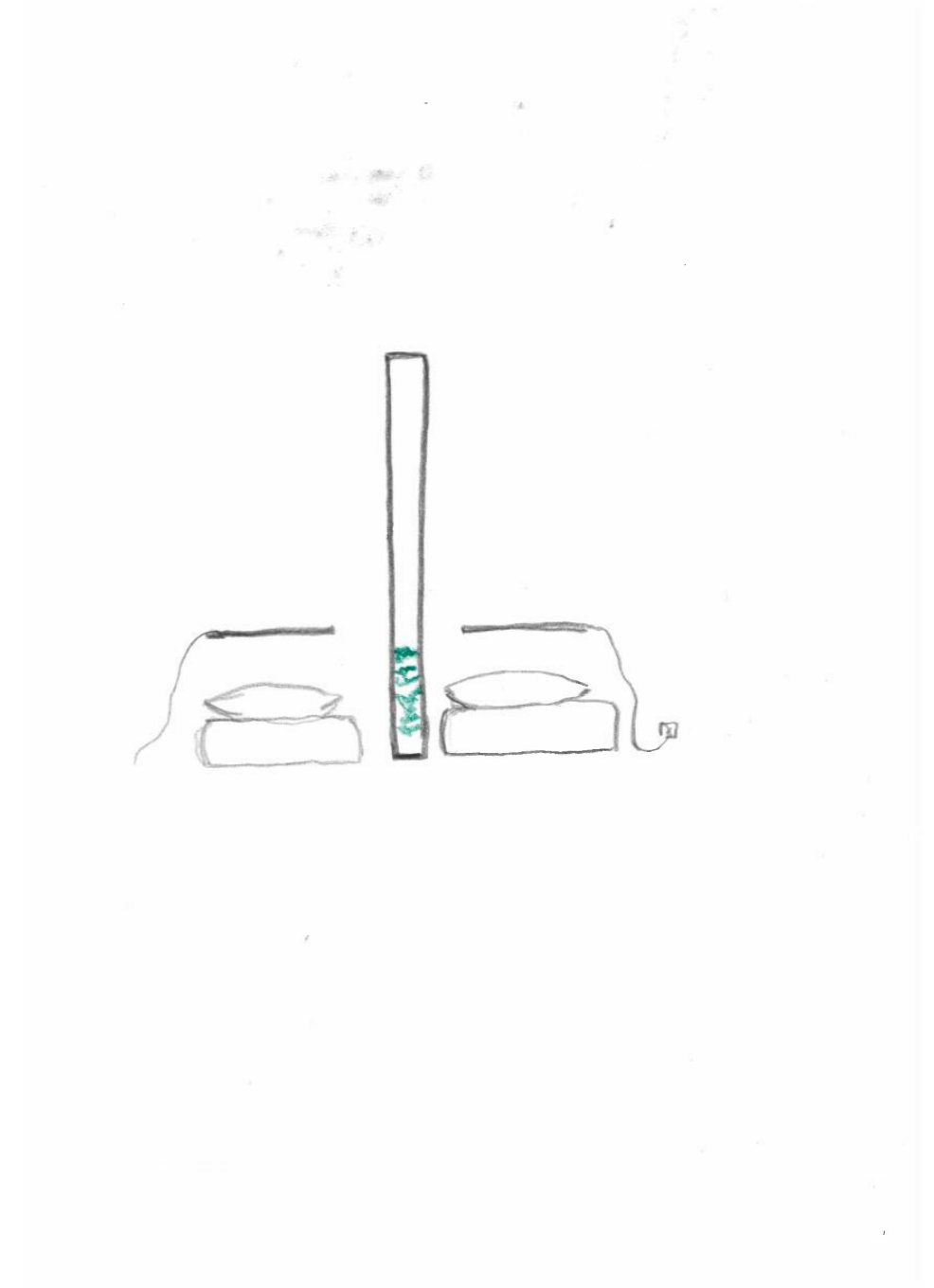
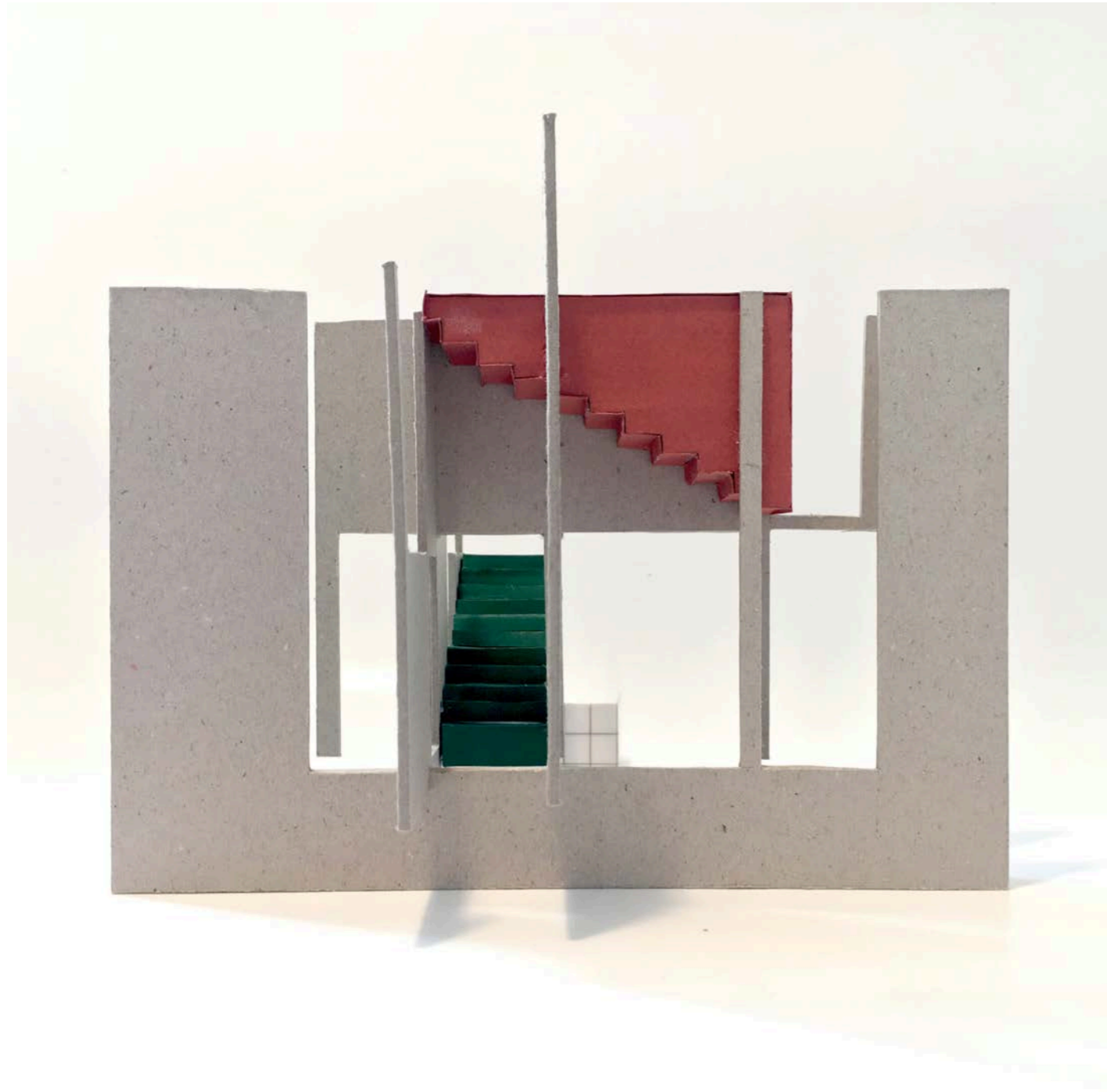

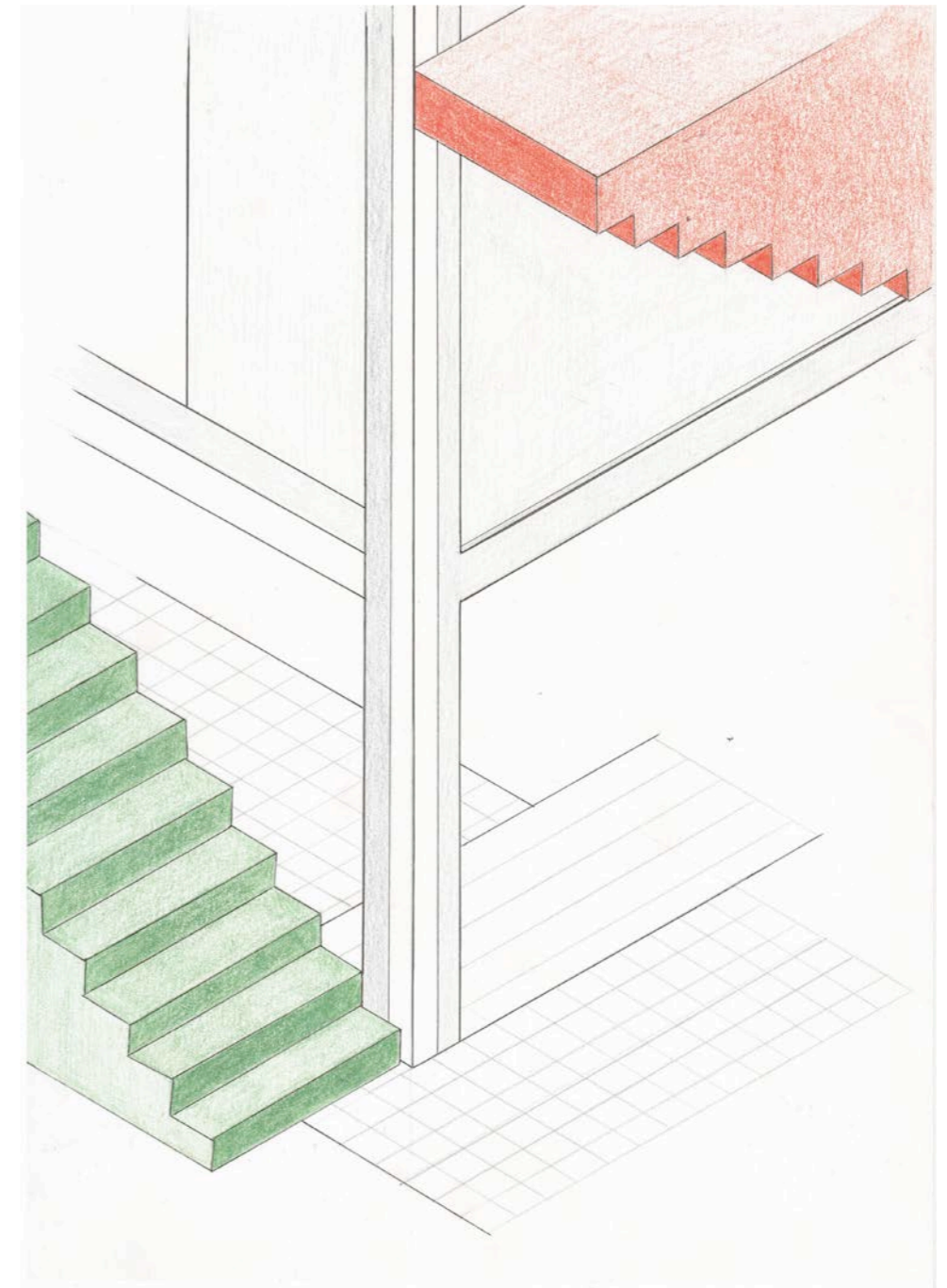
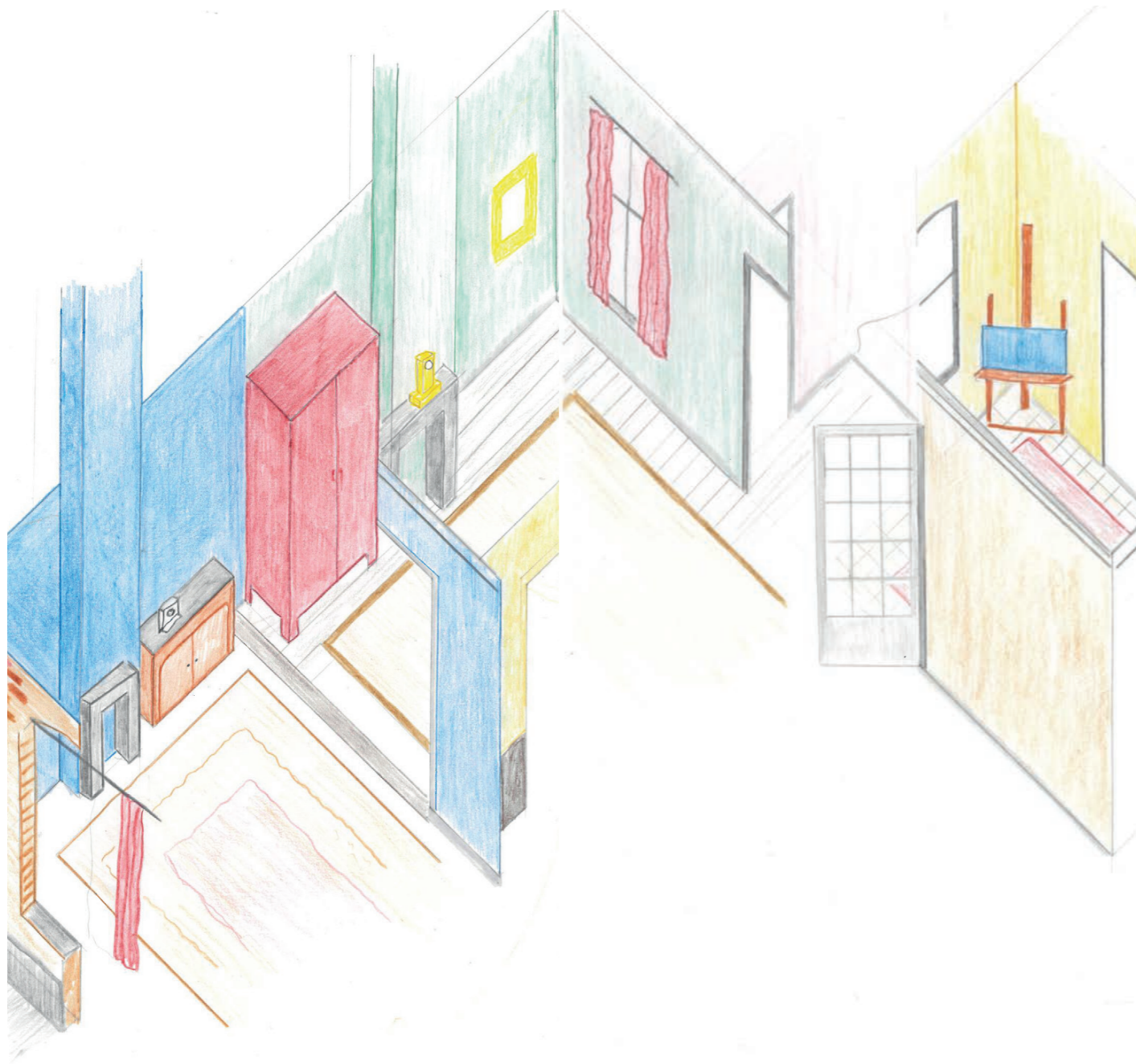

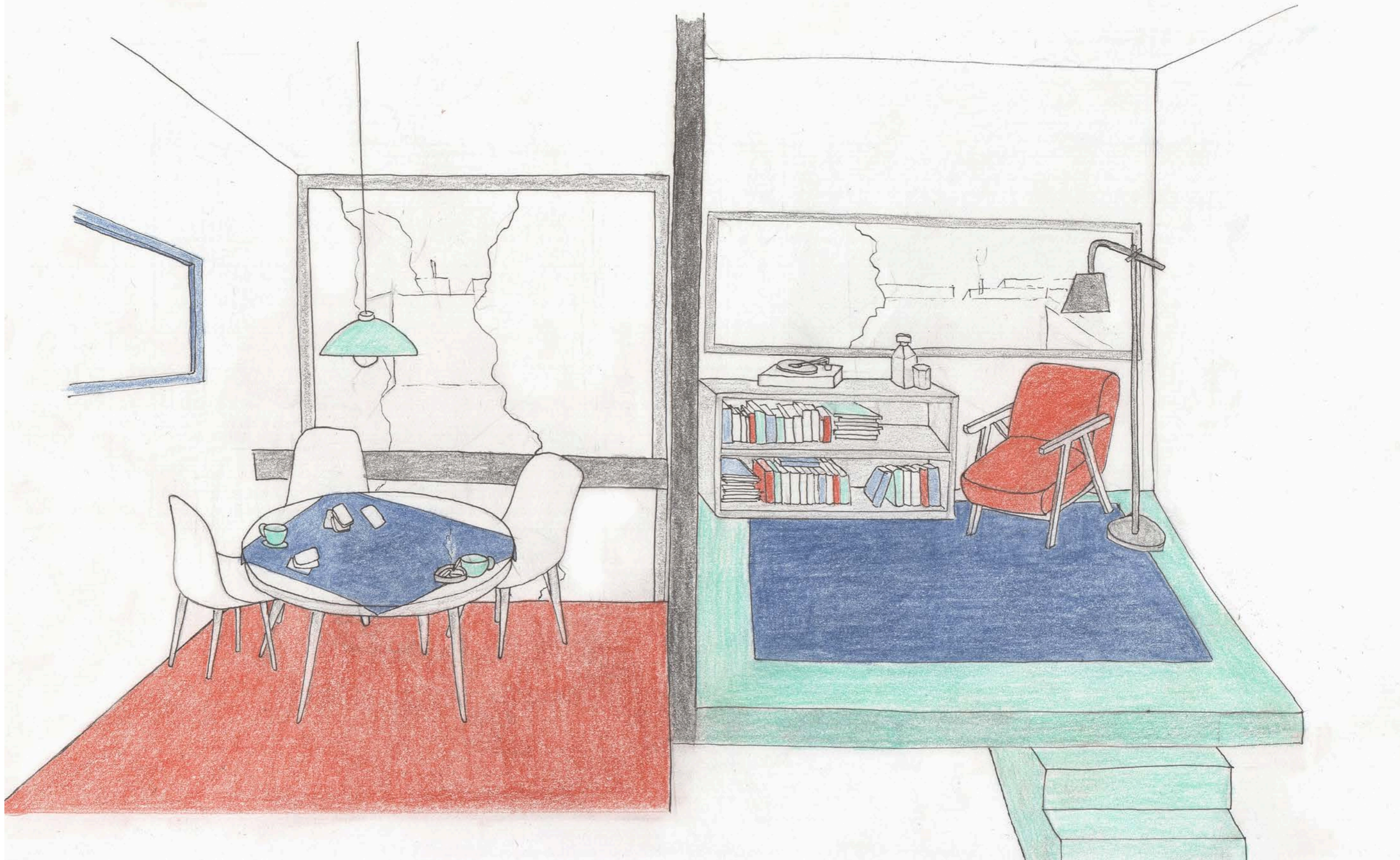

US in BE: House with three sections

HIM¹, THE OFFICE

He always sits on the window's side, his back facing the empty garden. It is better that way: even if he enjoys the sound, he always gets distracted by the view. Overall, this is the place where he can best focus on his work. That is mainly because he is almost always sitting across him. The typing sounds always gets him in the mood for work.

HER, THE WORKSHOP

She opens the window. She can feel the busy atmosphere of the street below. When working, she tends to sprawl out: brushes, drawings and stains usually end up all over the place. But she is always careful not to touch his project.

HIM², THE WORKSHOP

He likes to come here after dinner. Working with his hands really helps him to disconnect. Sometimes, she is still here, working. Other times, she already done for the day. Now, he is building a chair. When that will be done, he will fix her easel, as he promised.

HIM², THE OFFICE

He likes the window's view, to see what is happening in the garden: Somebody sunbathing on a deckchair, taking a smoke break, the sound of an argument on the phone. This always inspires him to write. He also enjoys it when he comes around to work and his images scroll across the computer screen.

HIM¹, THE REDROOM

Her pictures are dry. He takes them down while looking at them: it is funny how differently she sees things. Everything is now in place, the red light fills the room. He can start his work.

HER, THE REDROOM

She is so glad to have a room such as this one. It really was not necessary for her. She did not even know how to use it before she moved in. But now he taught her, and she has been doing it ever since. She likes to come here once every two weeks, or whenever she needs a little bit of fun.

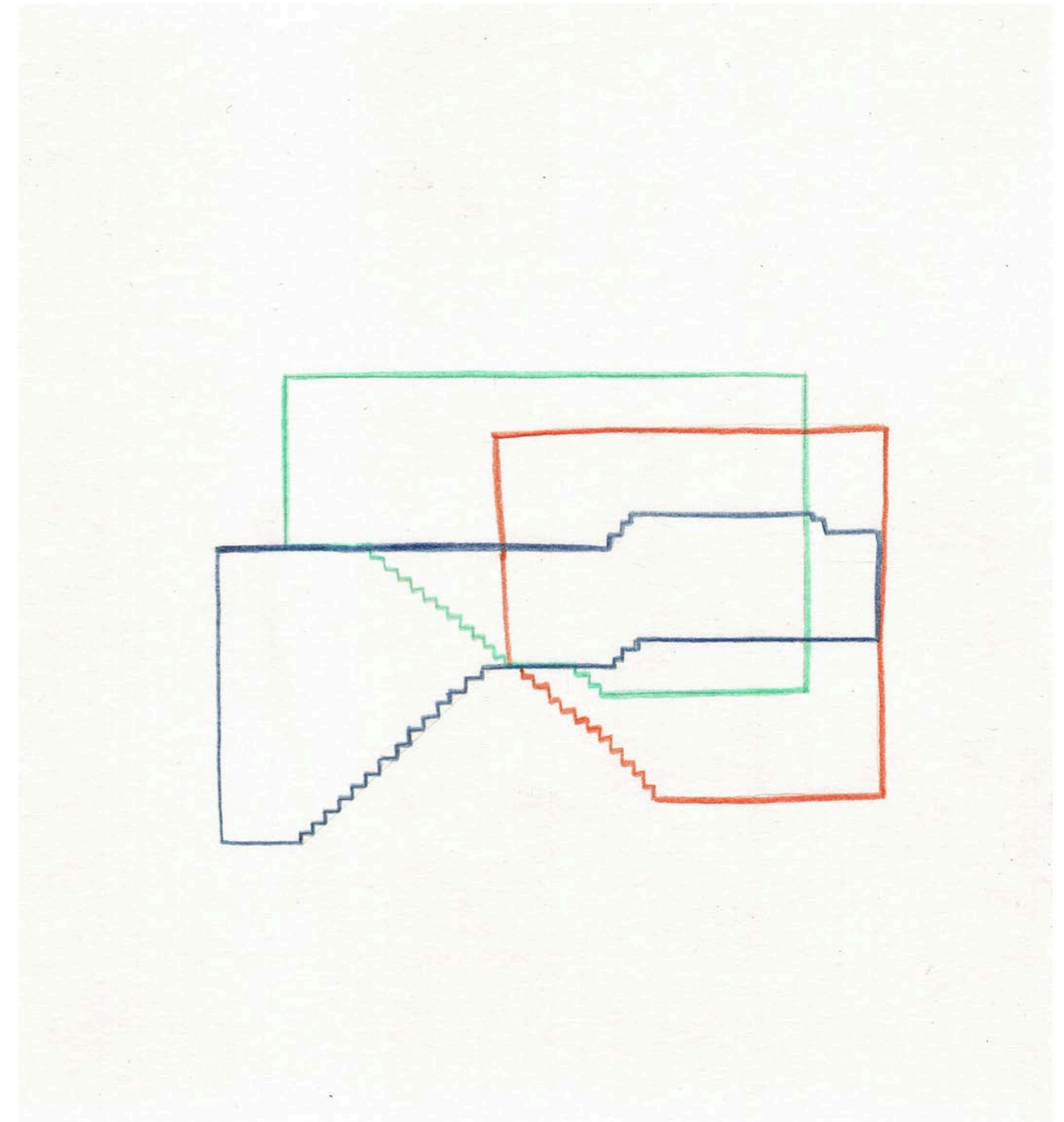

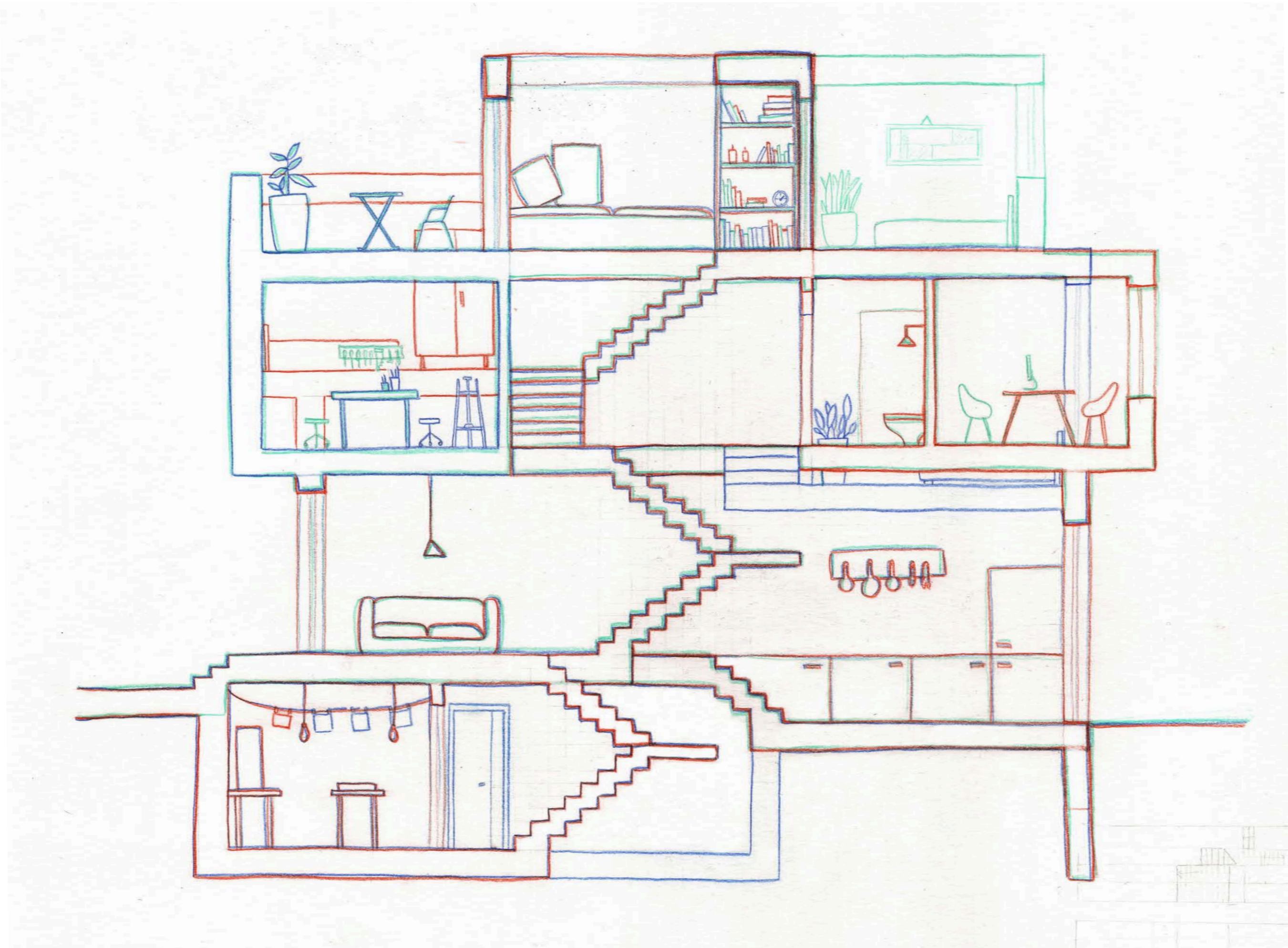

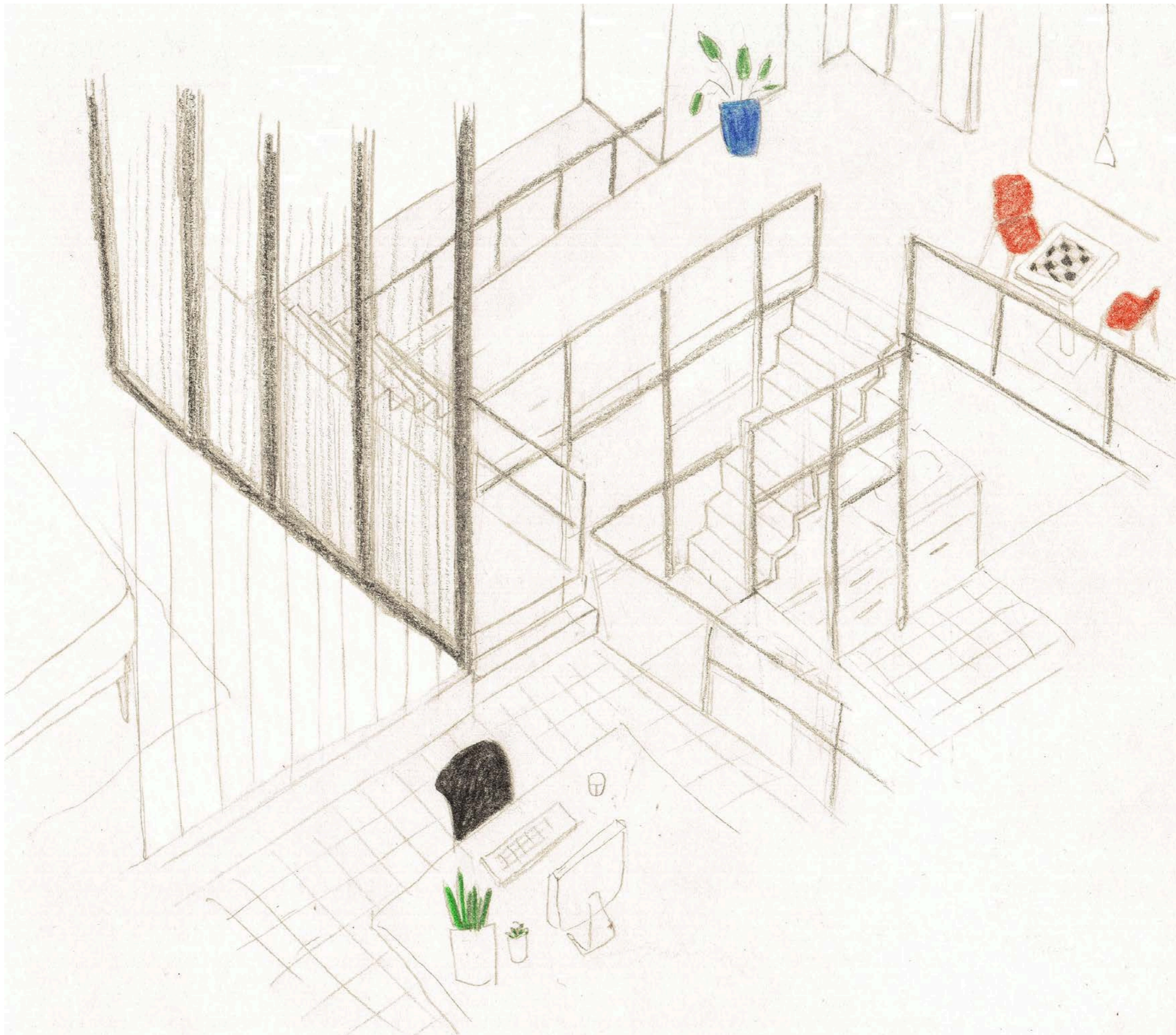

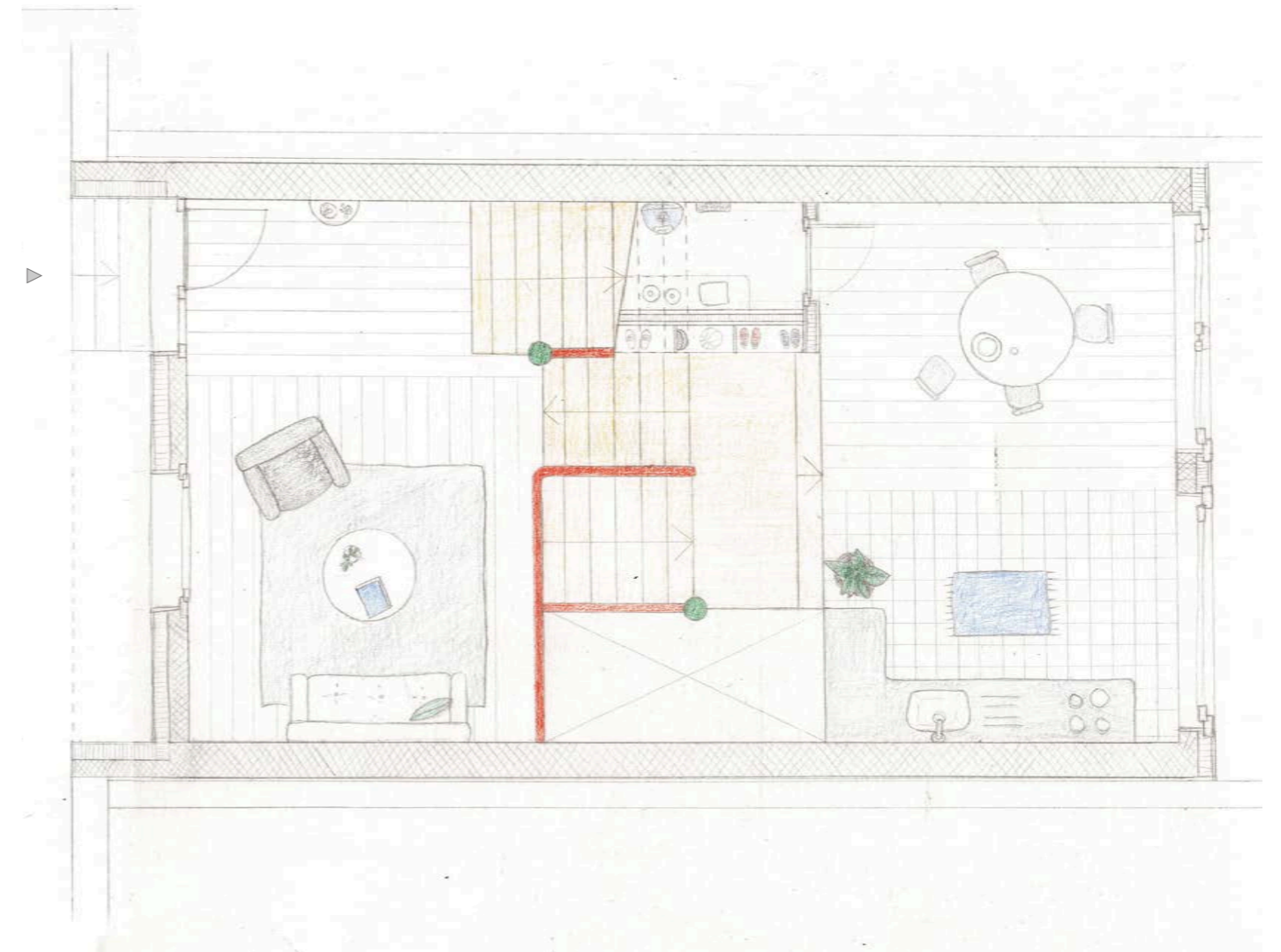
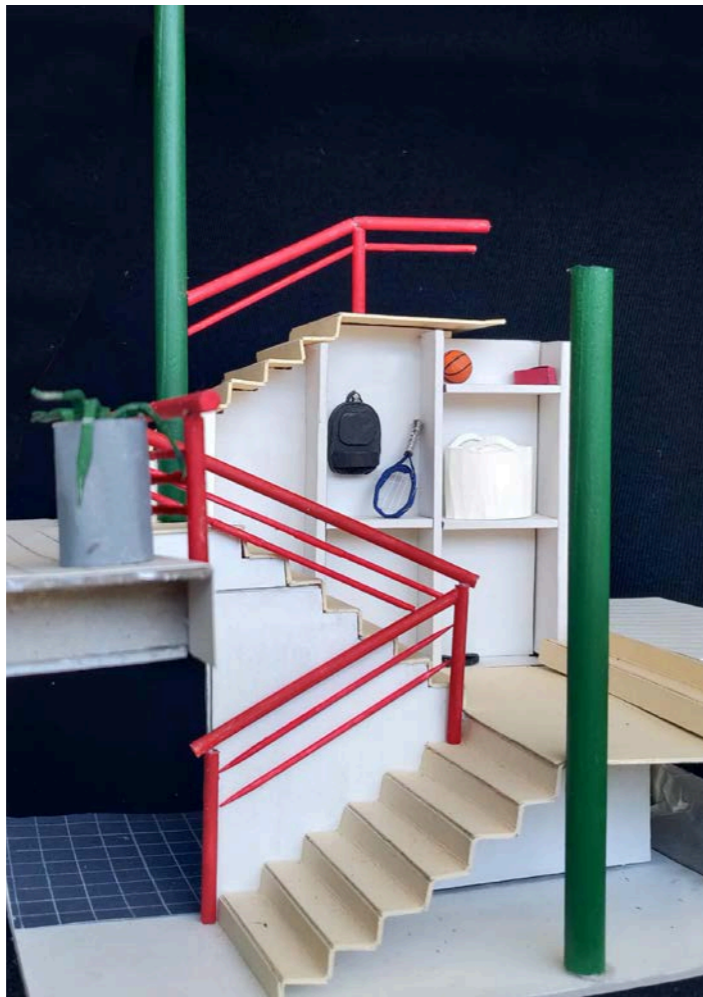

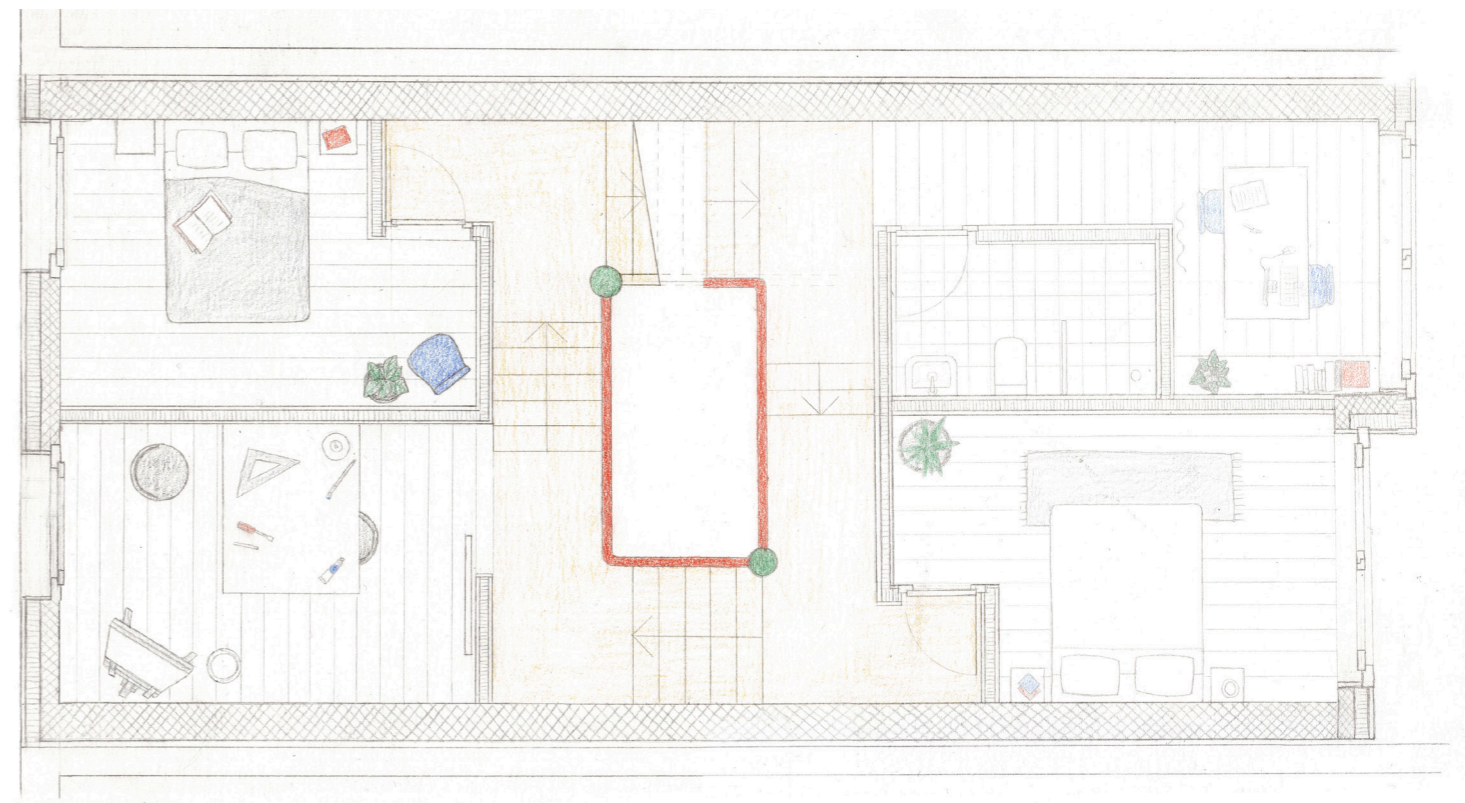
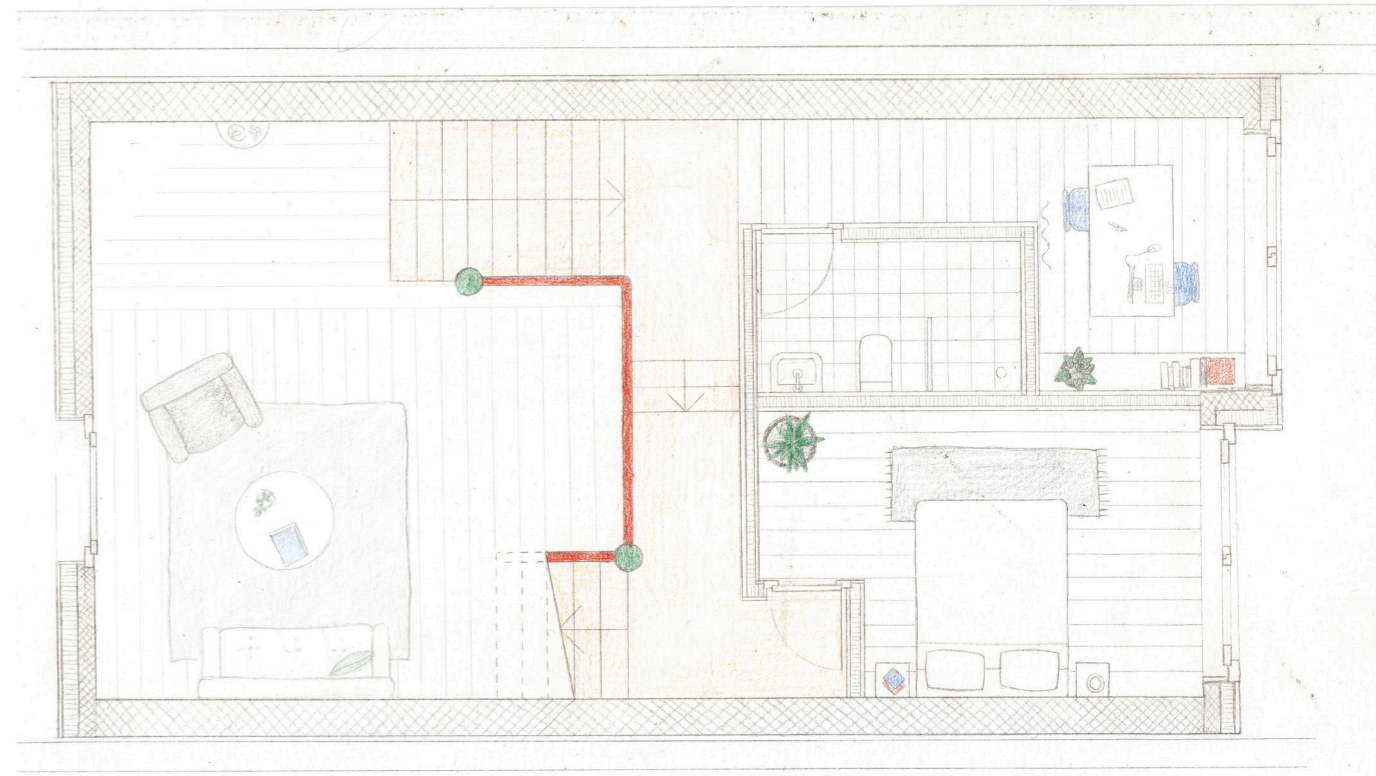
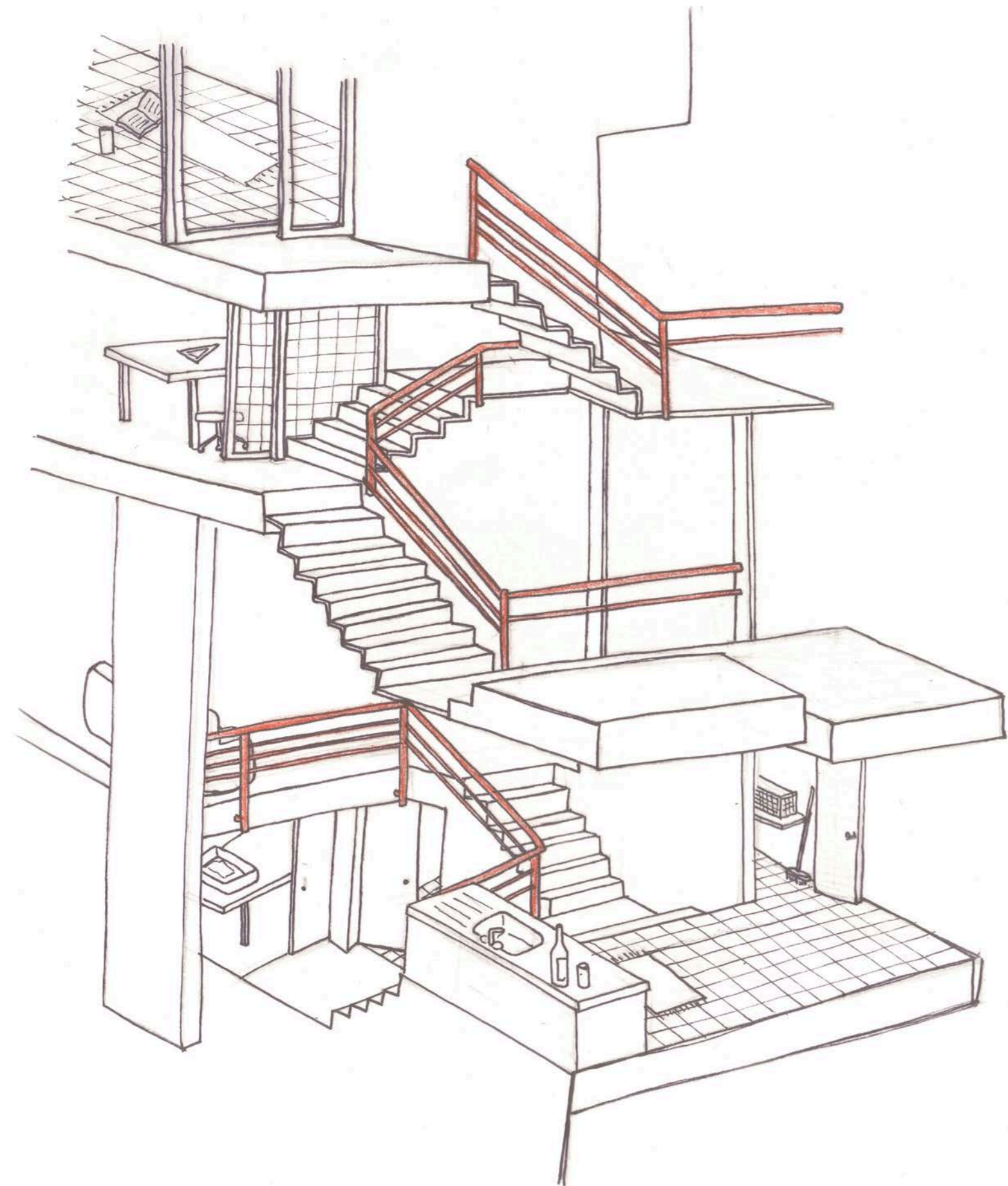

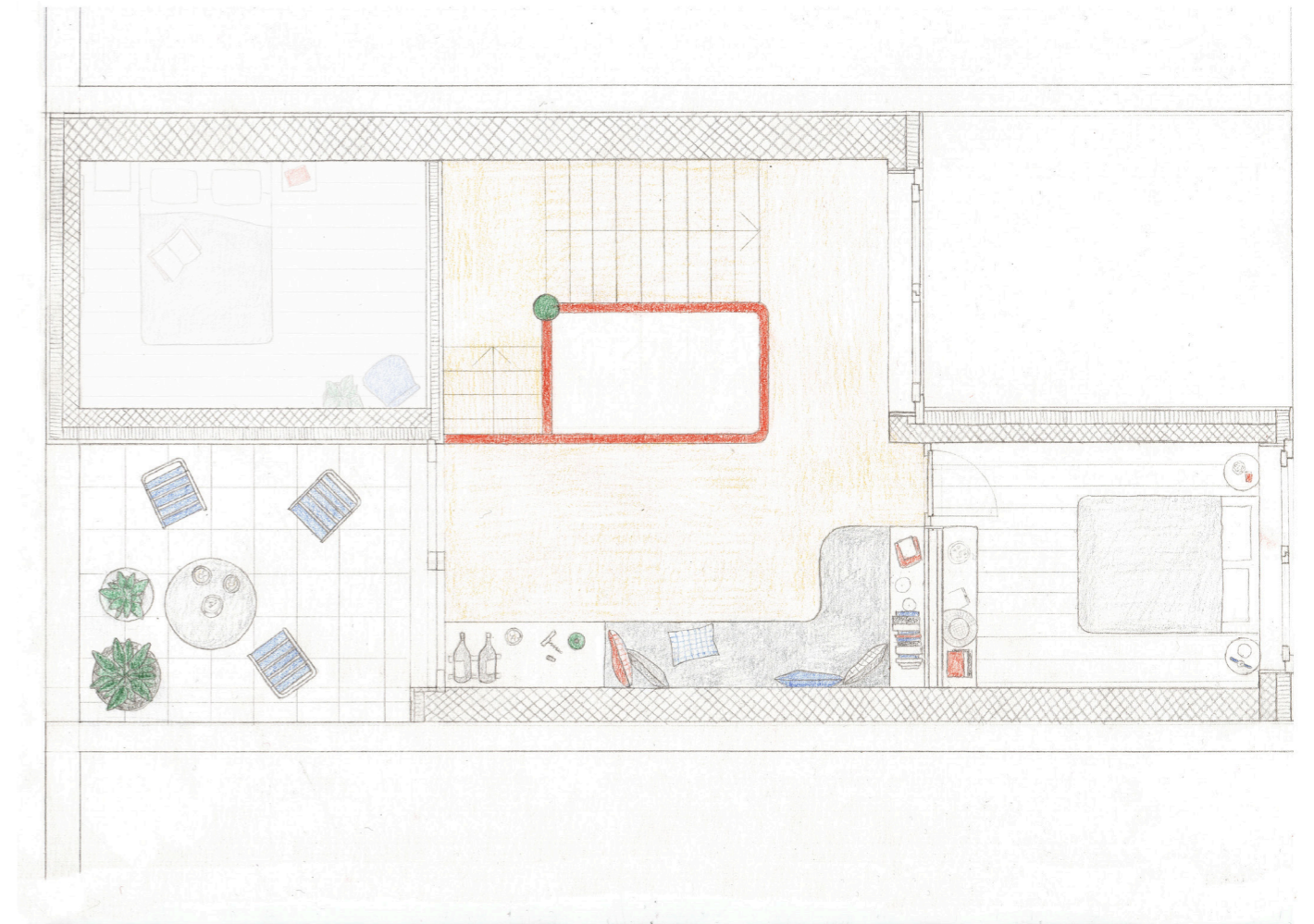
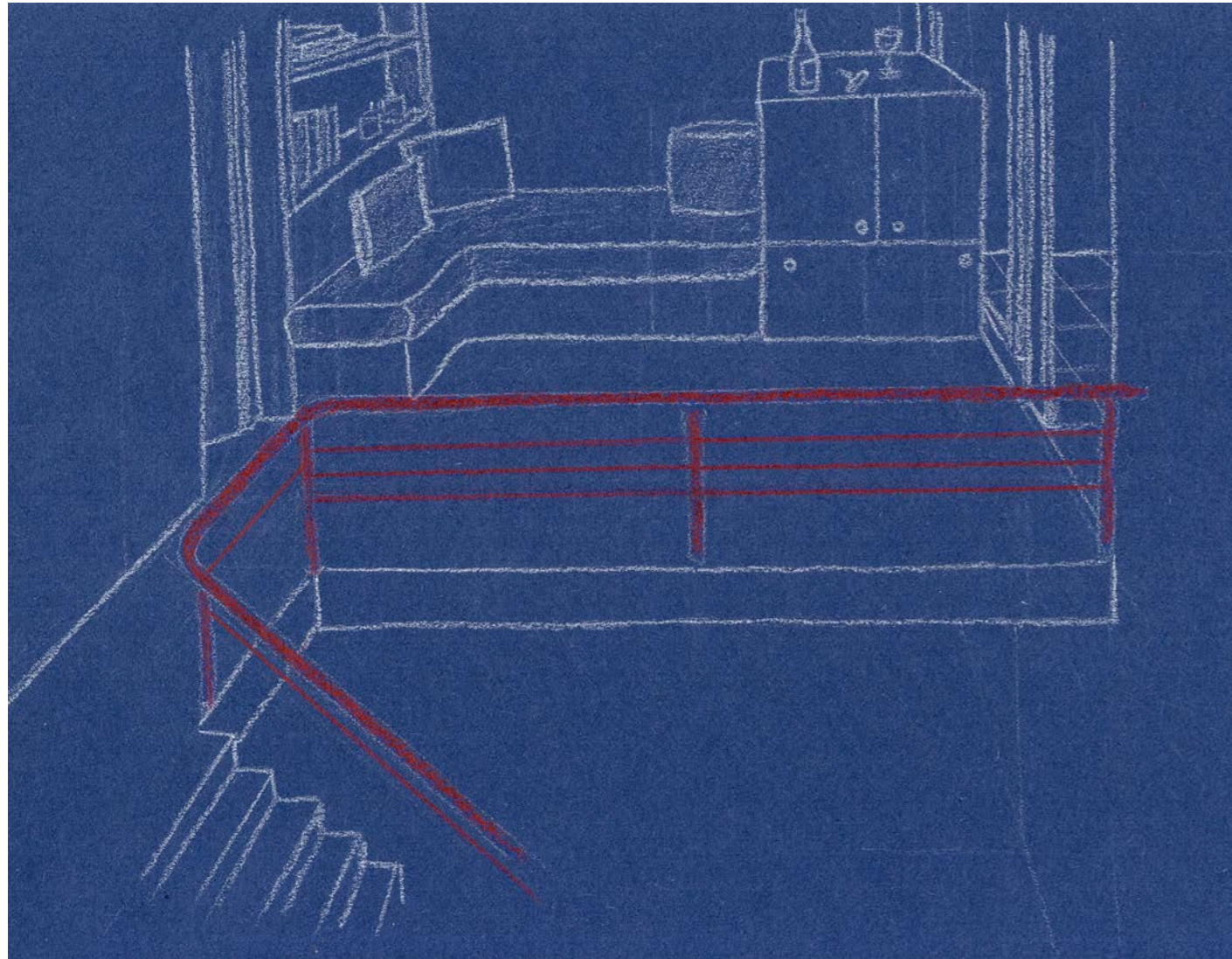

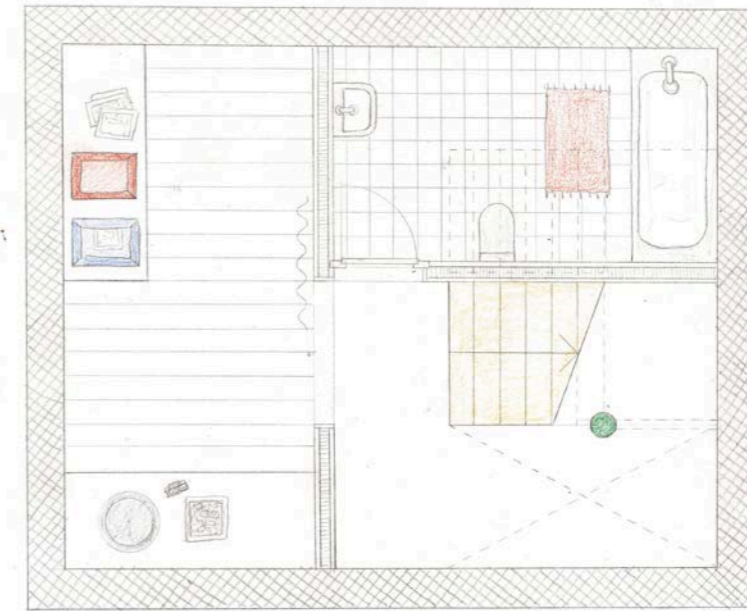

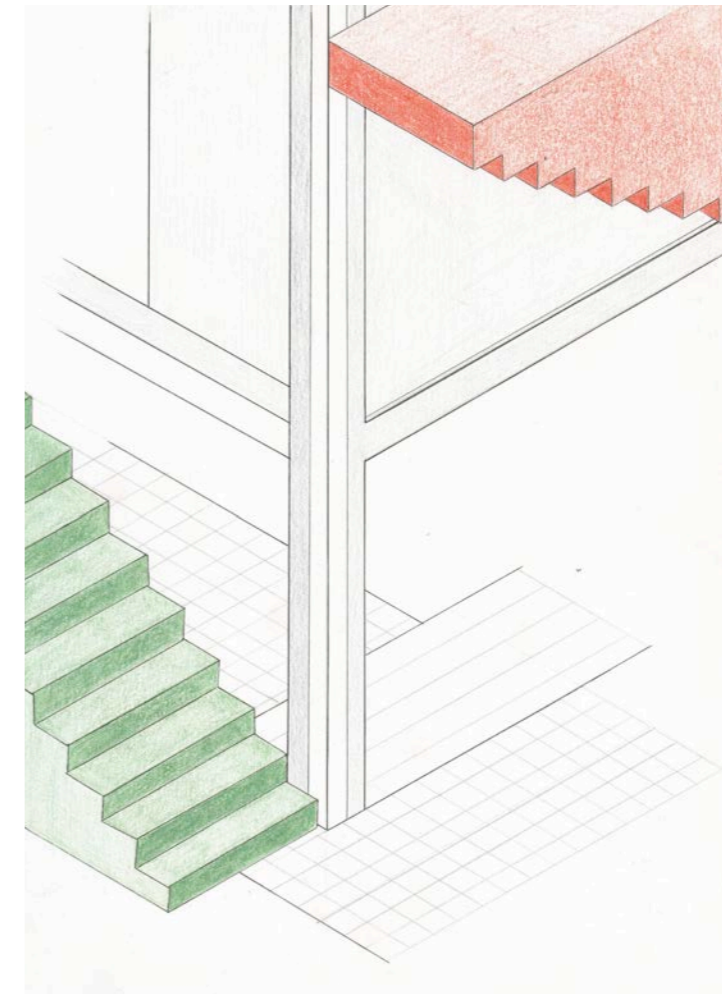
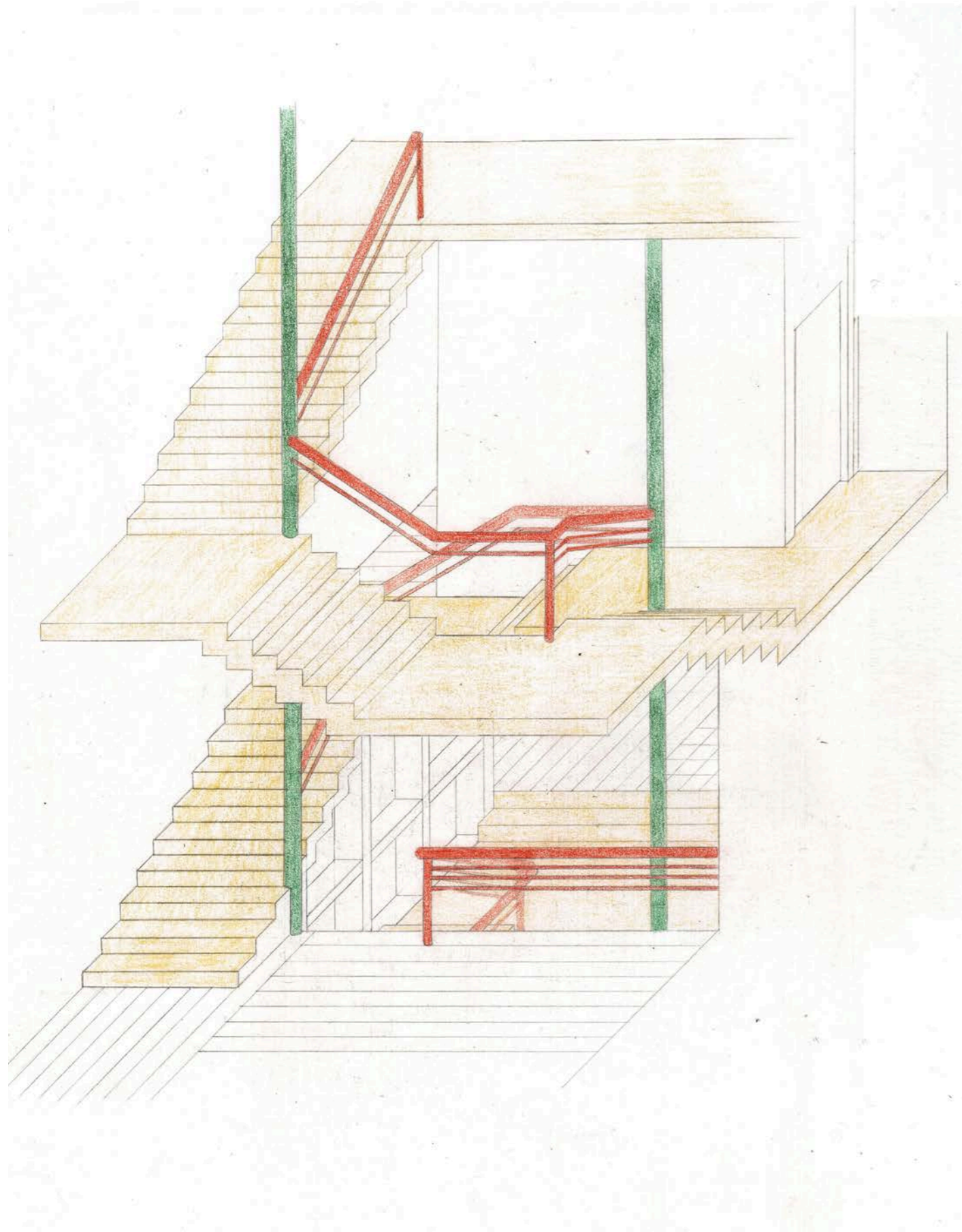

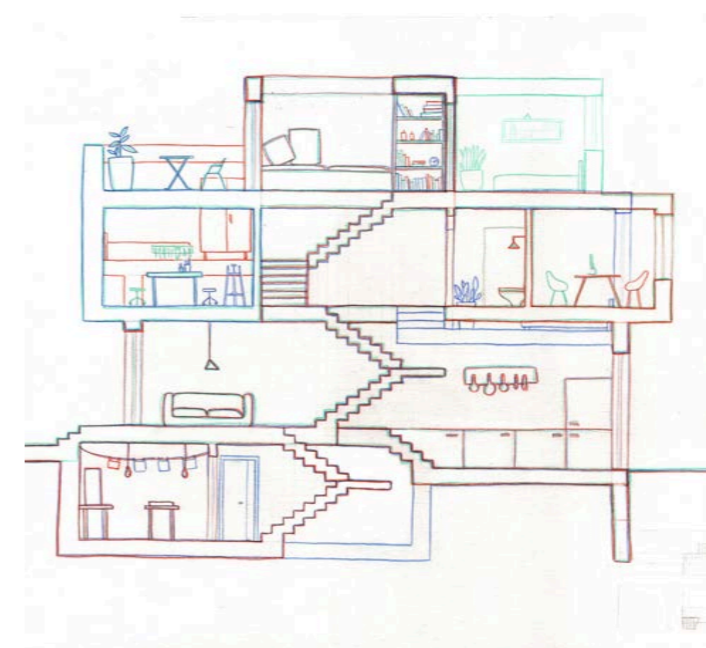
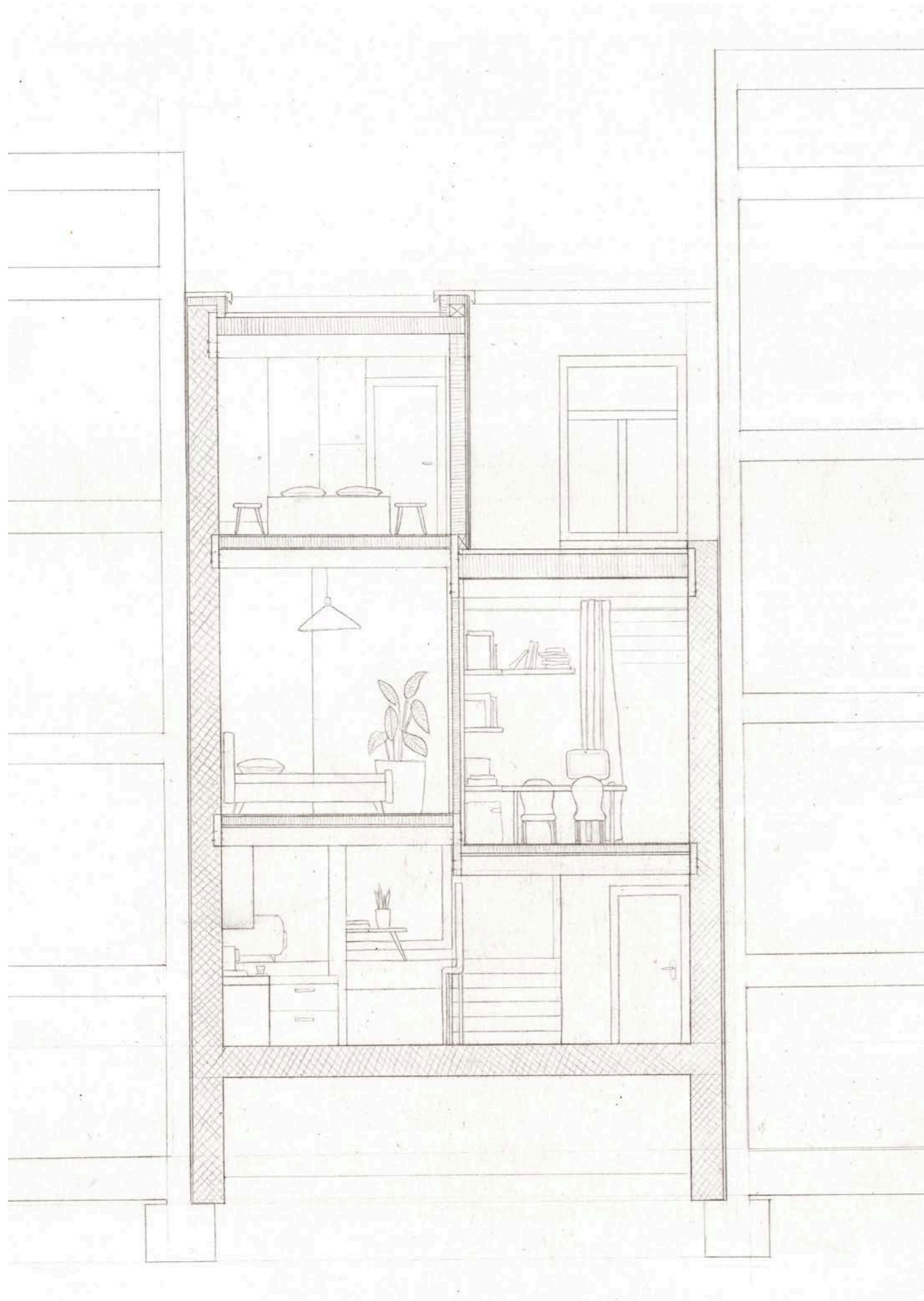

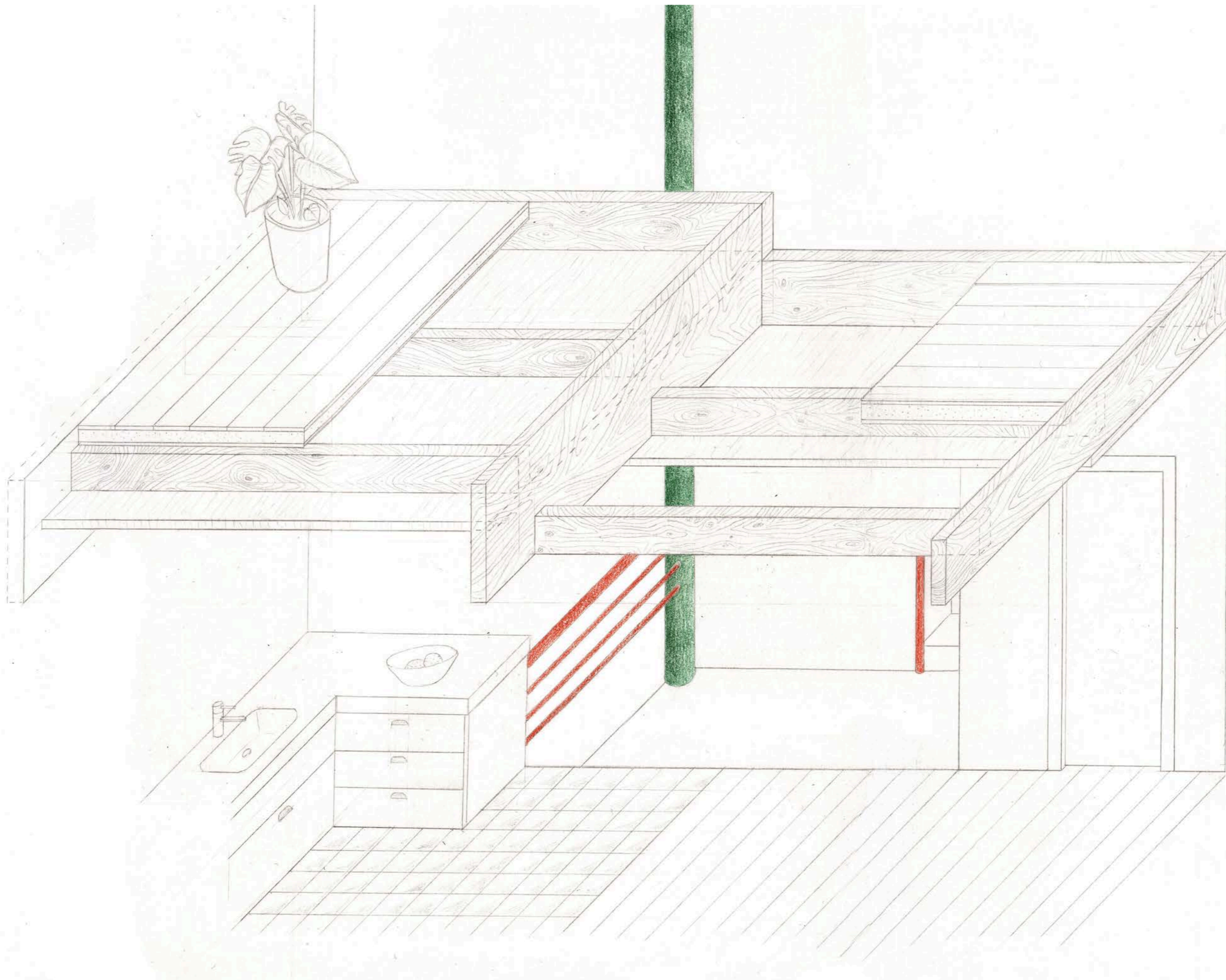

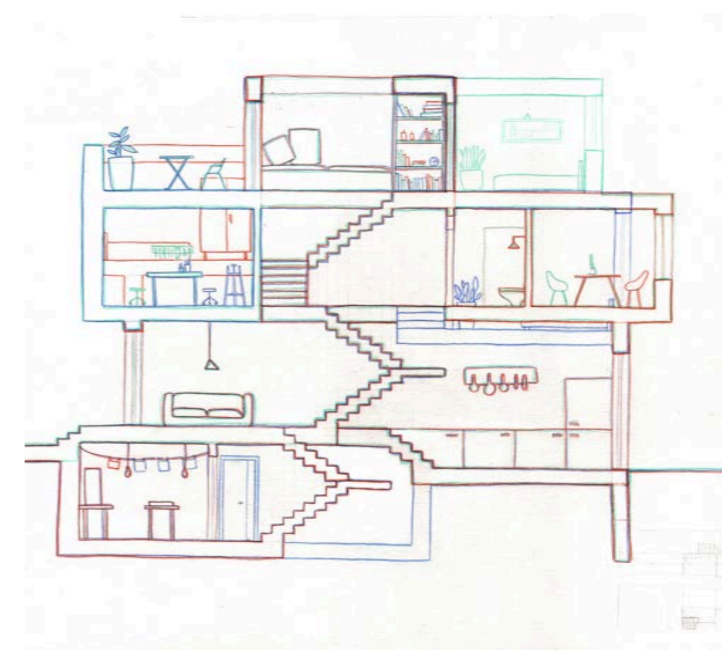

Movement 2

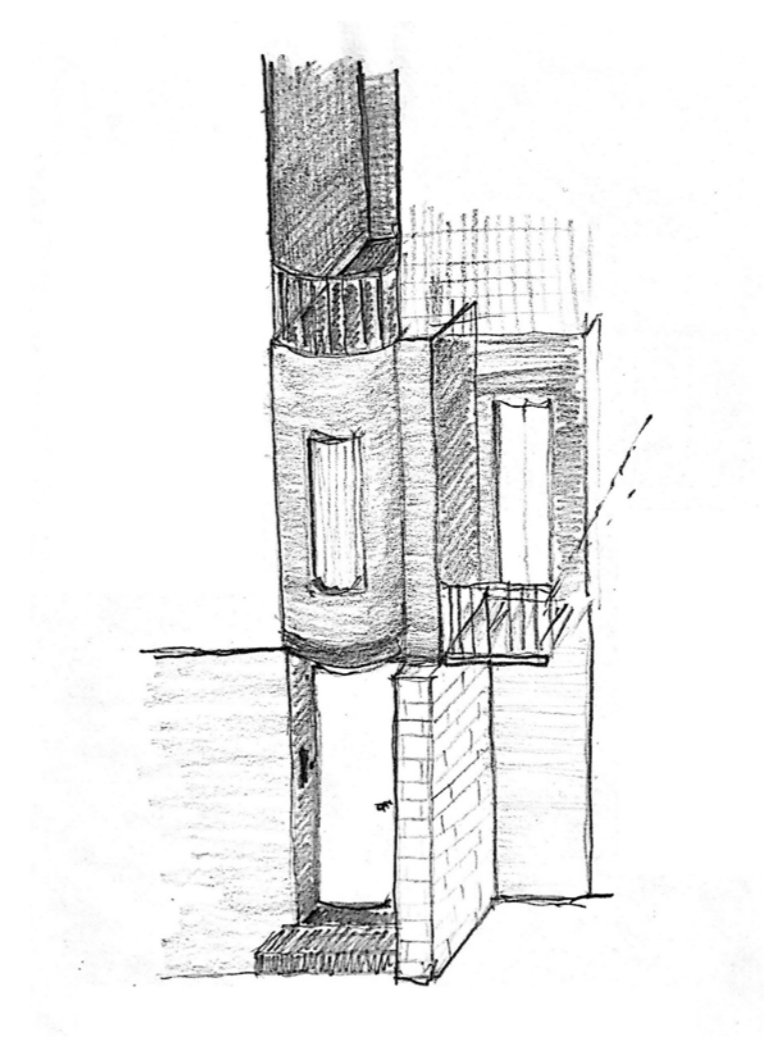

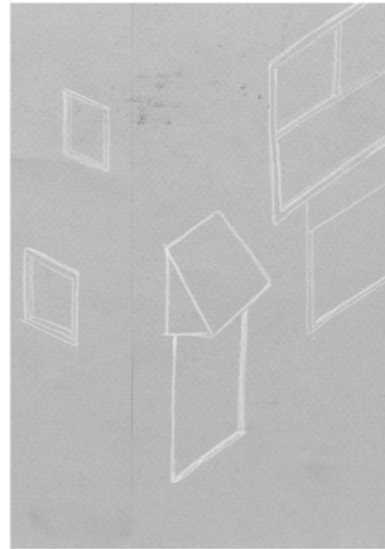

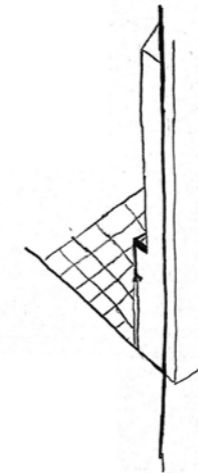
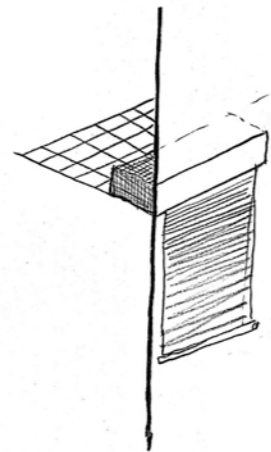
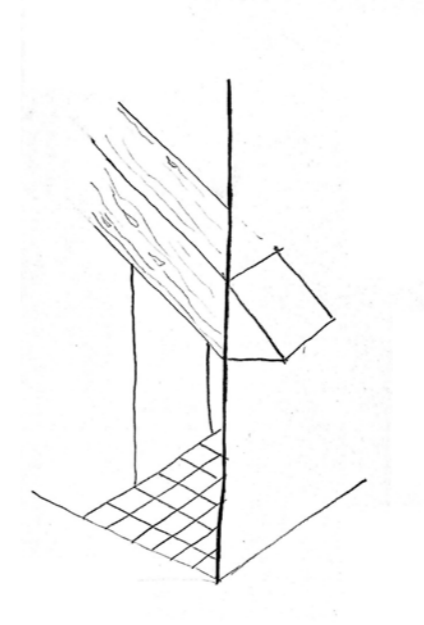
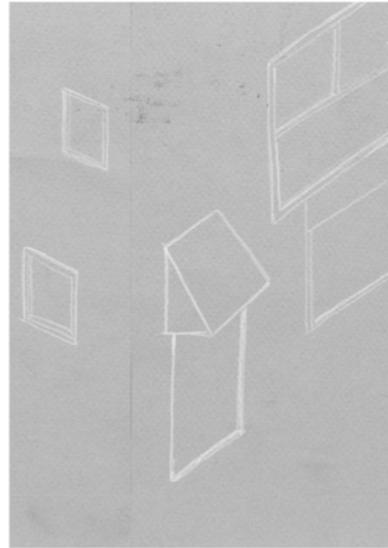

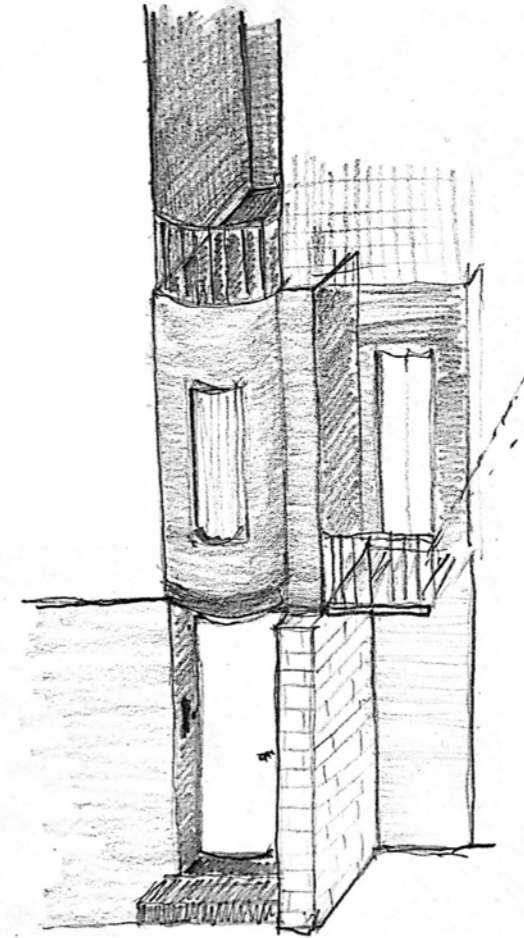
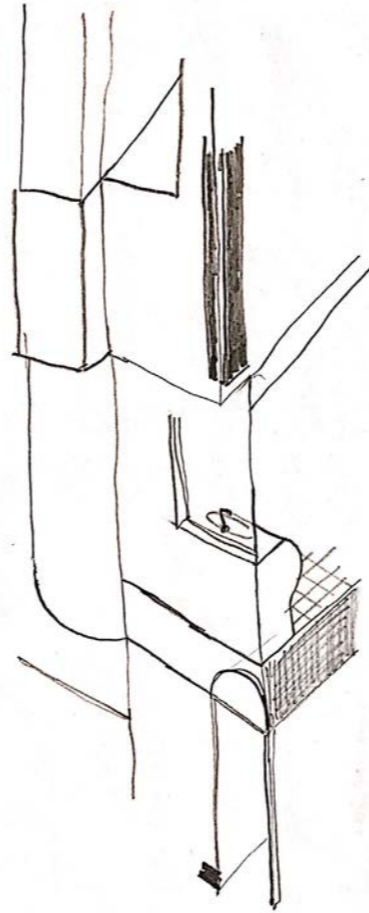
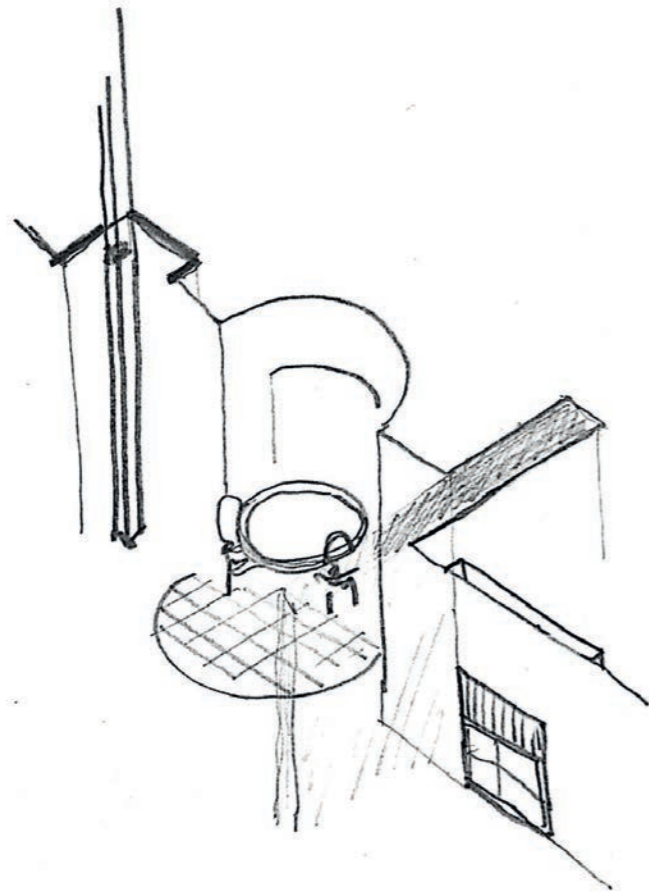

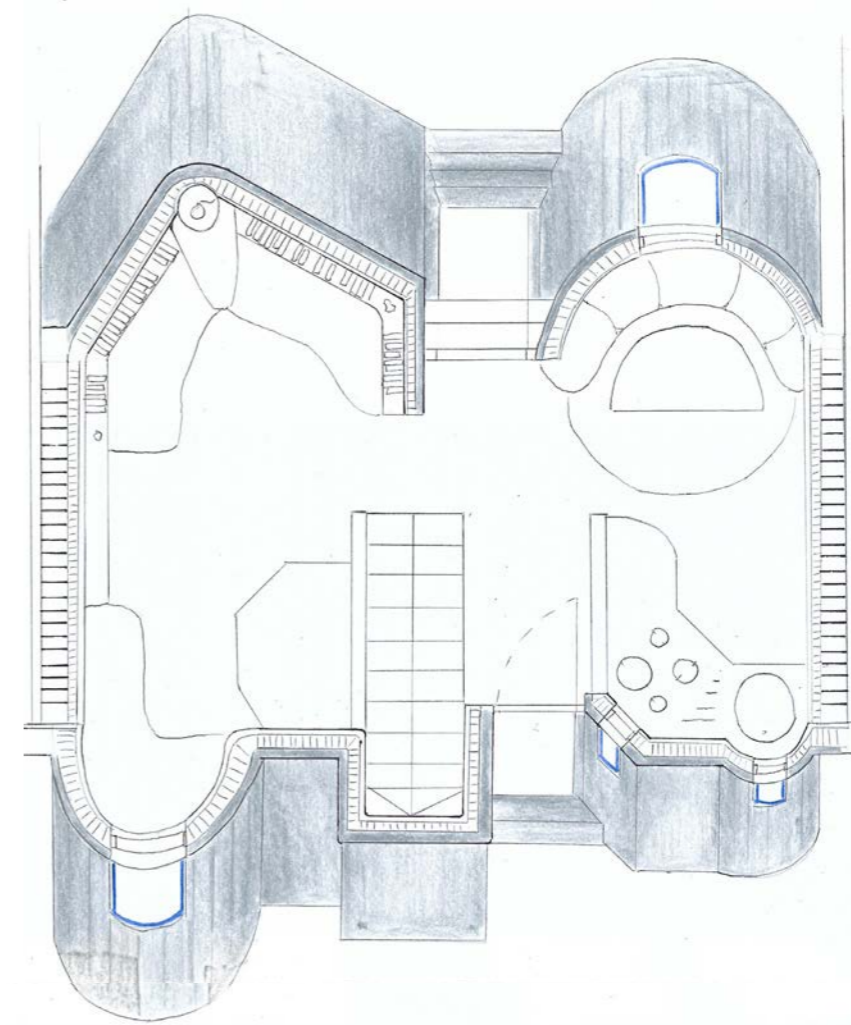
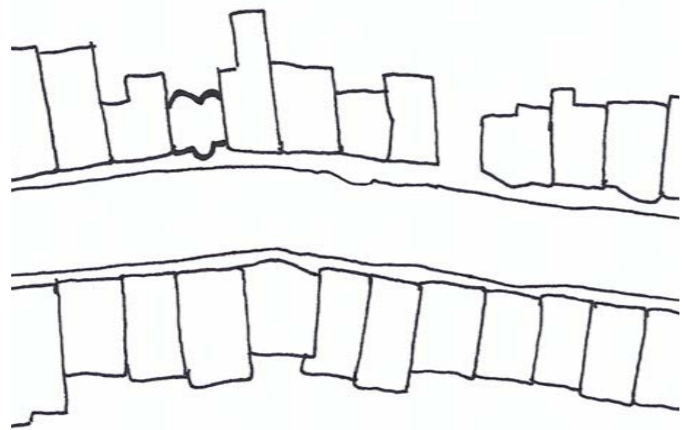
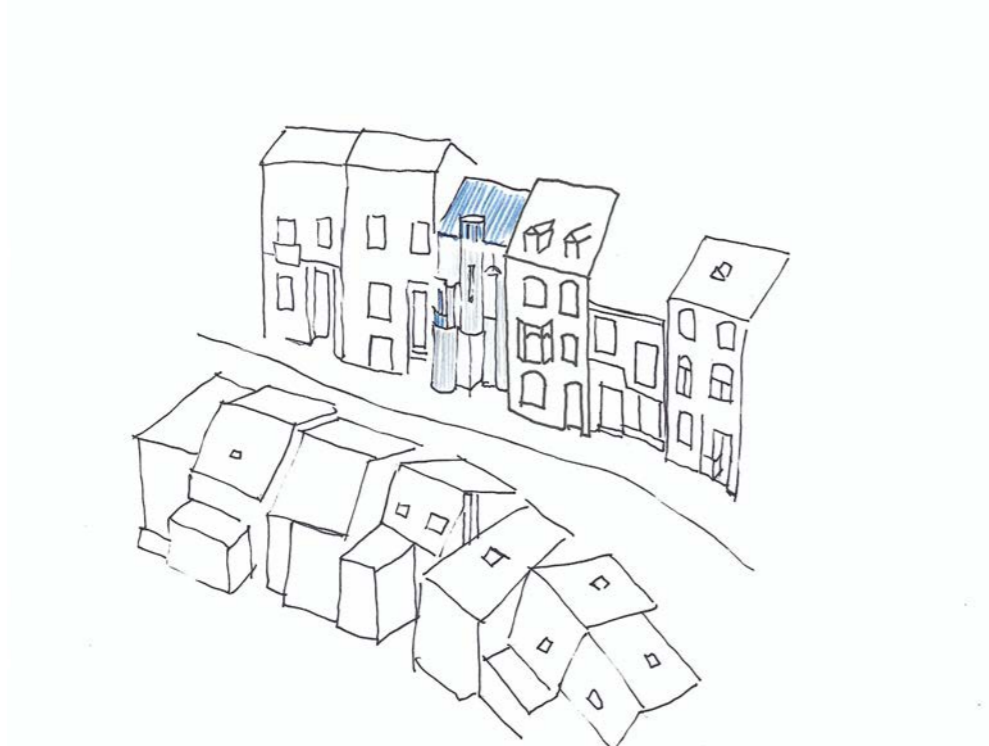

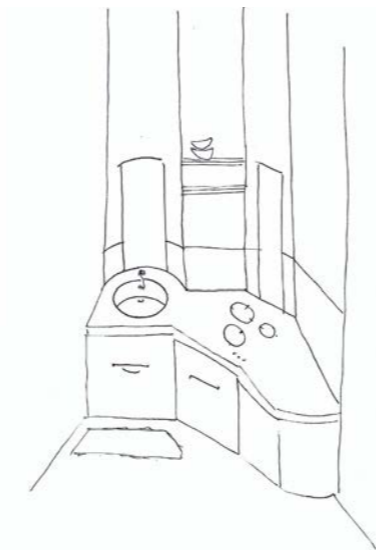
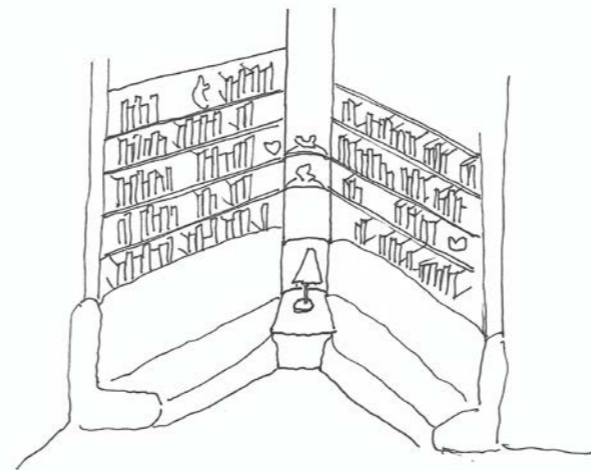
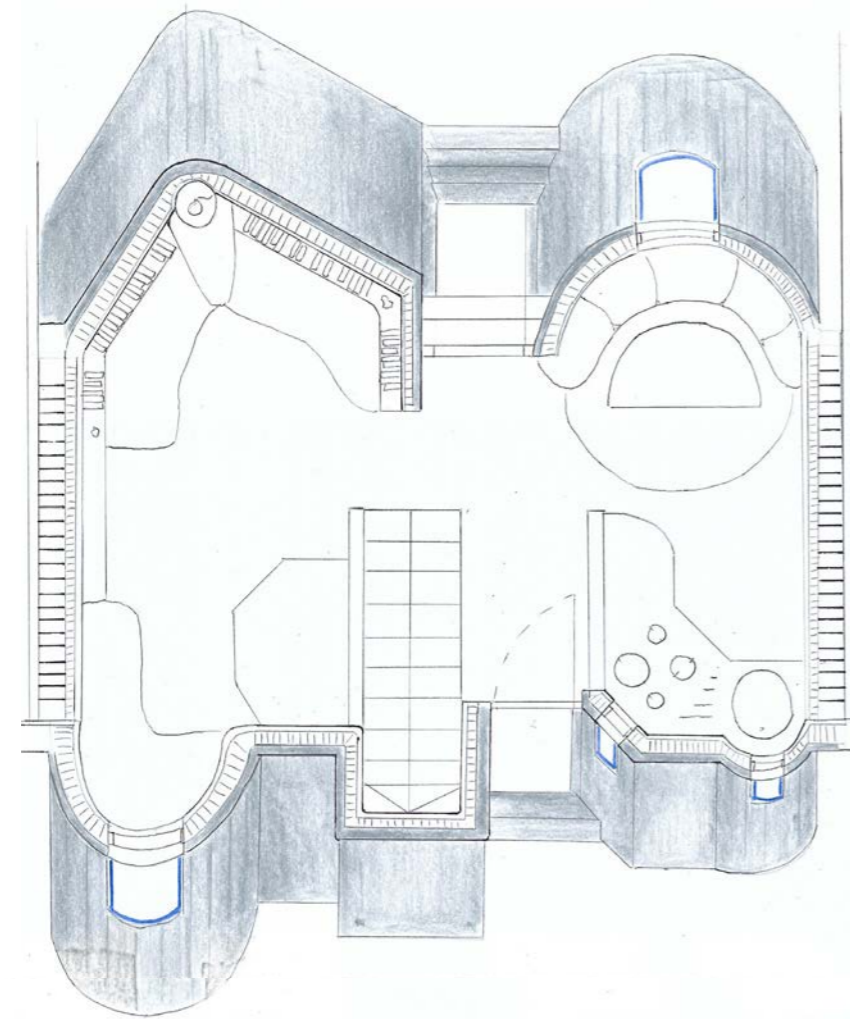

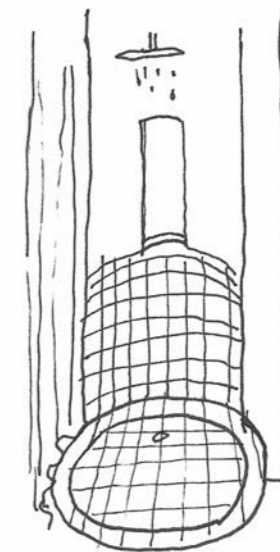
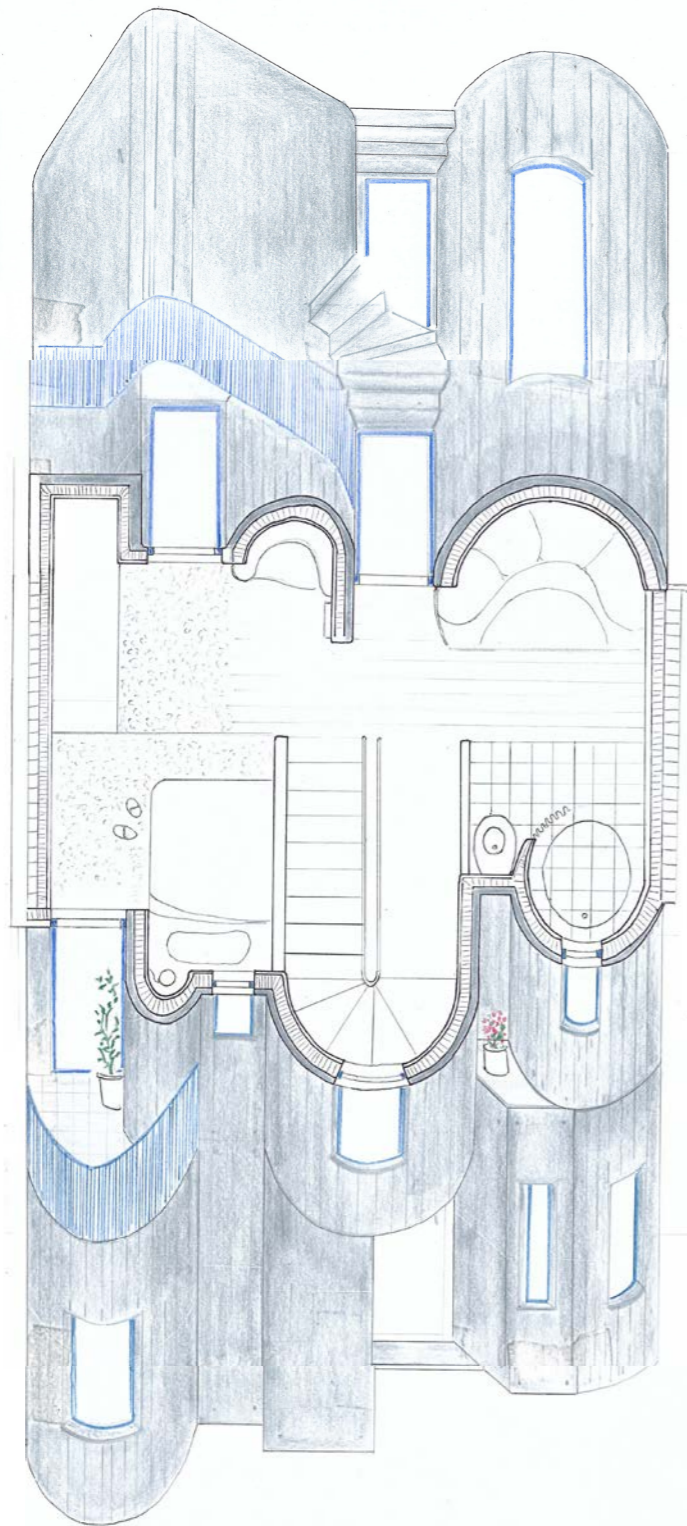

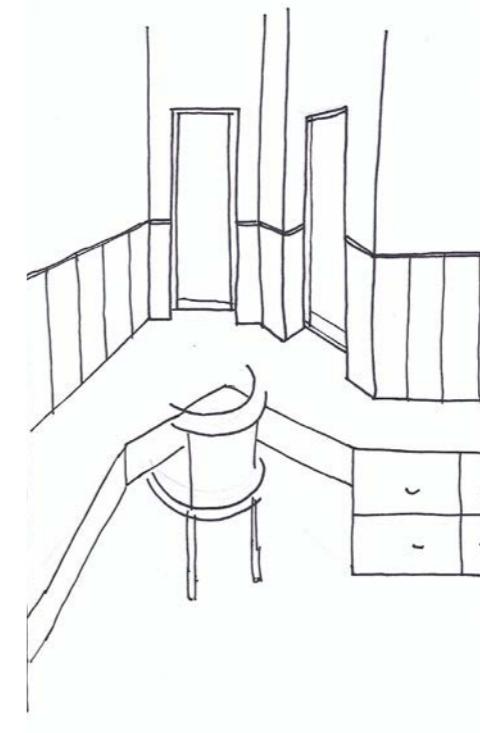
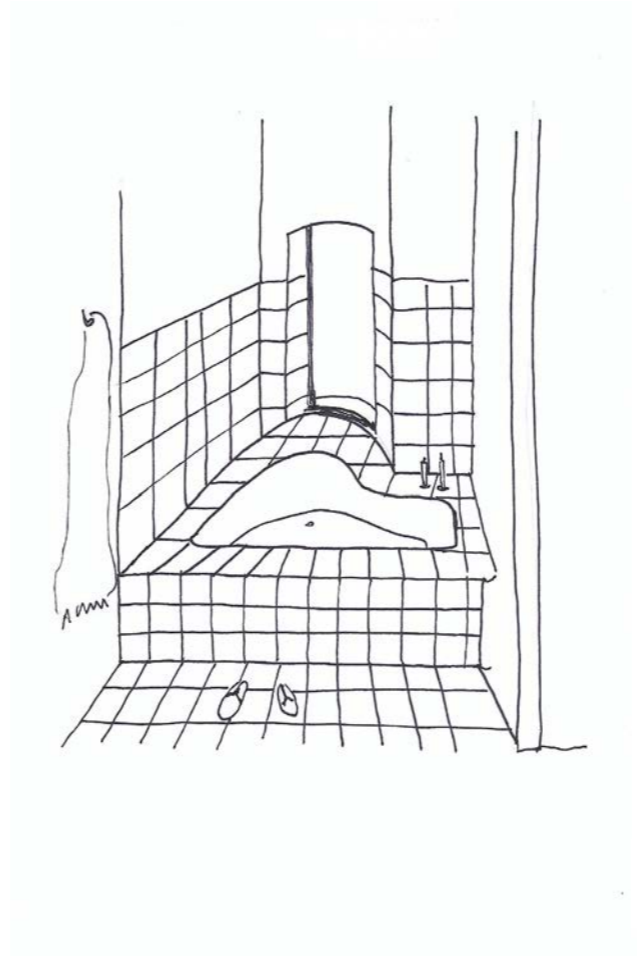
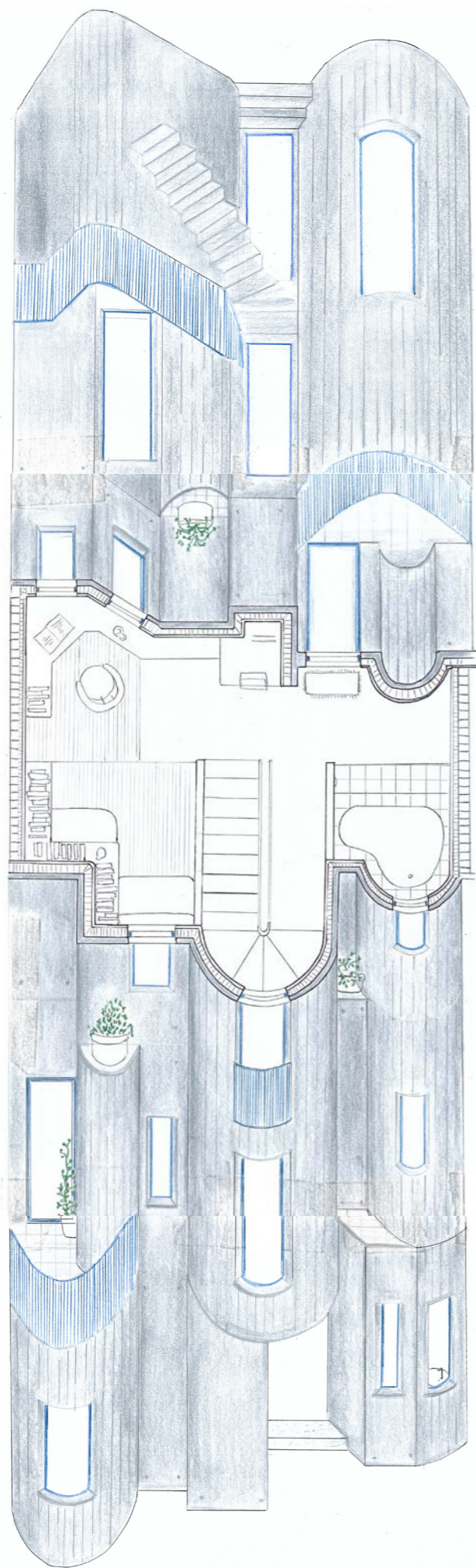





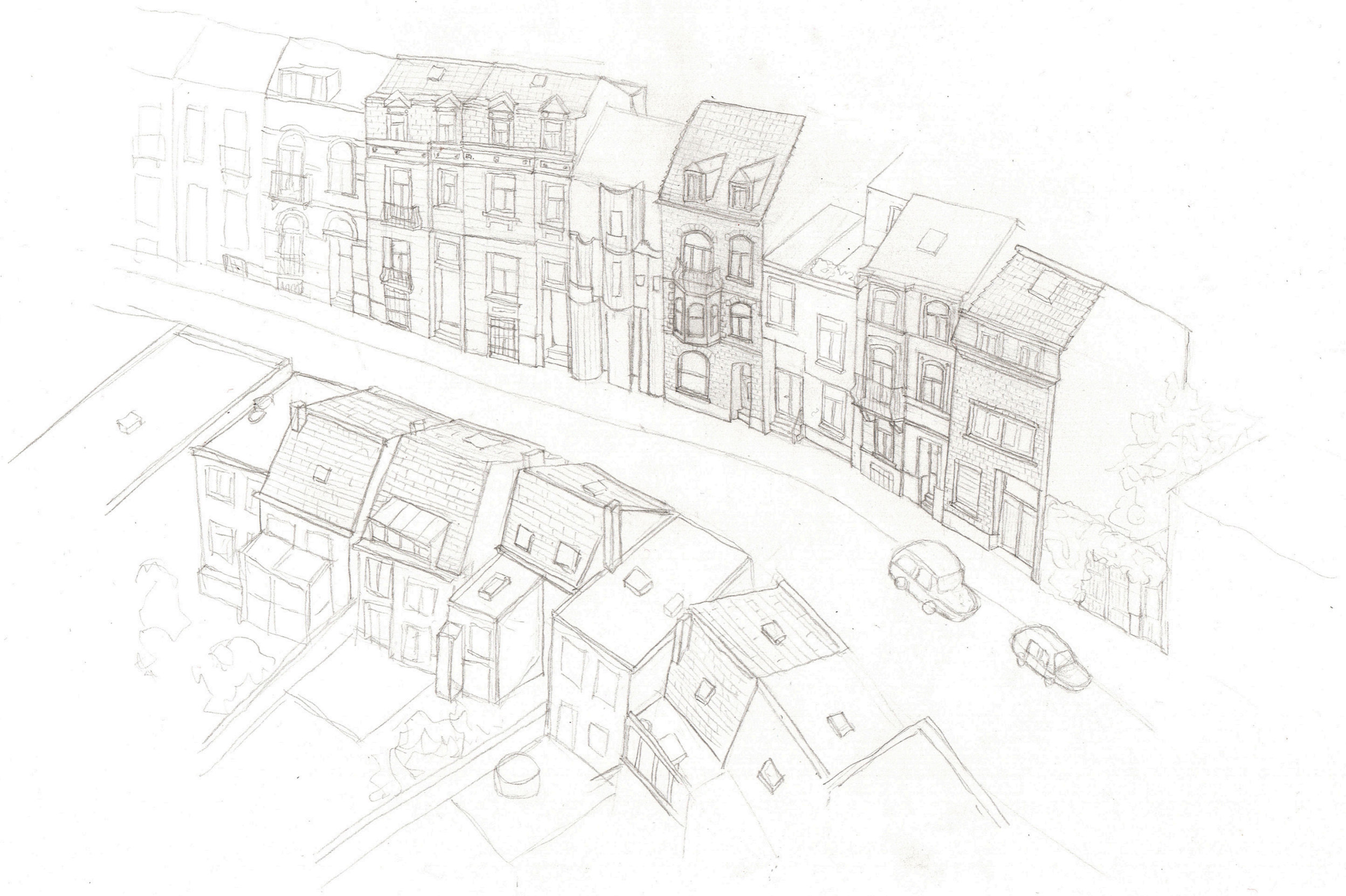

A

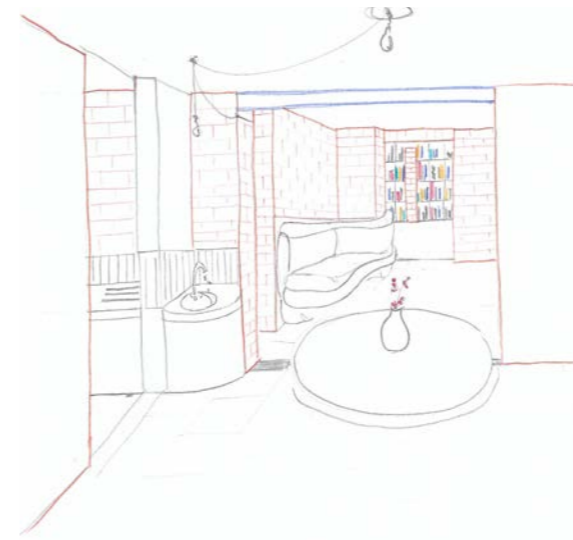
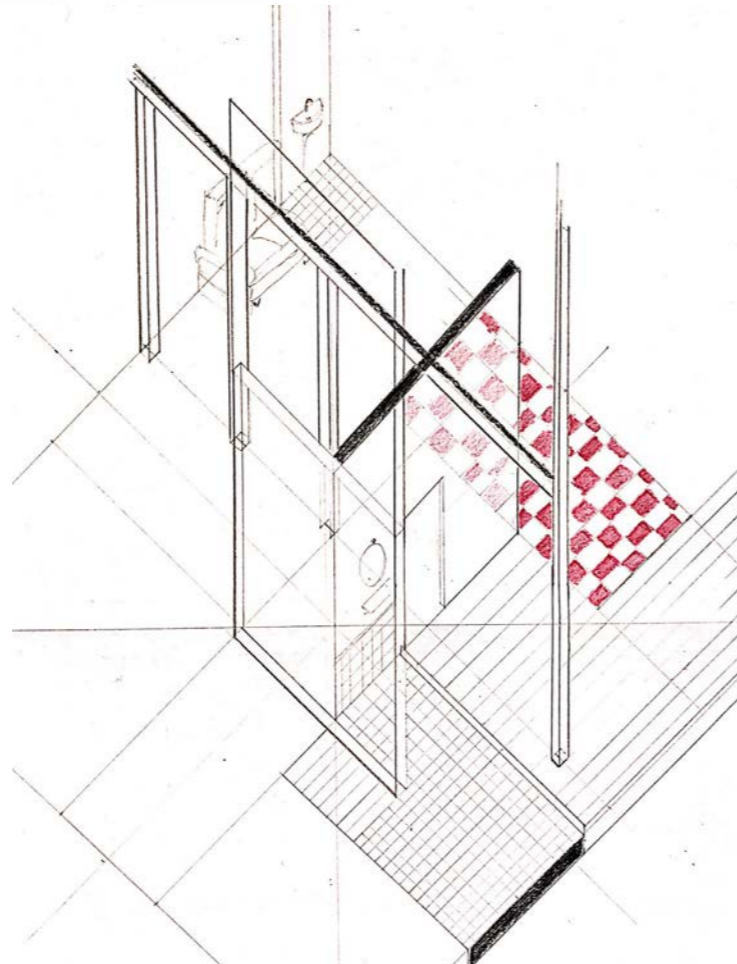
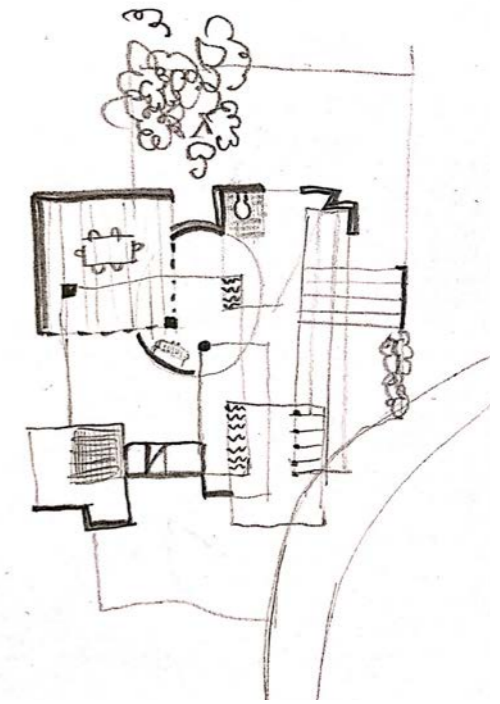
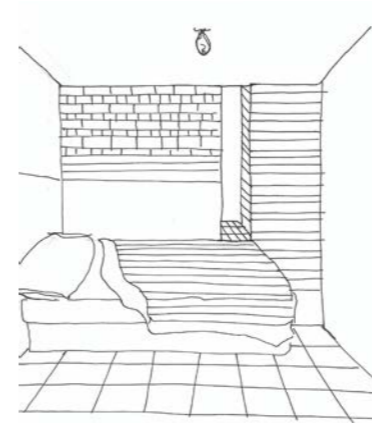
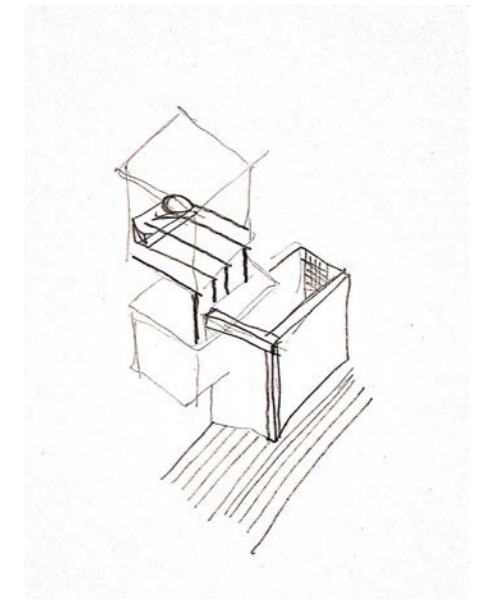
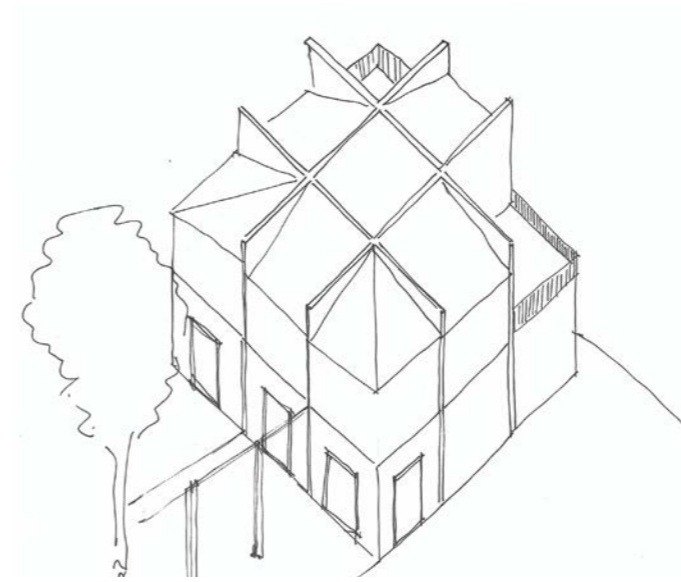
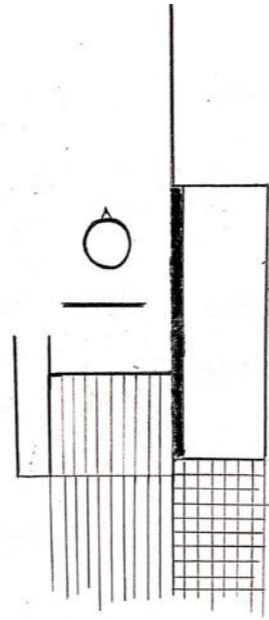
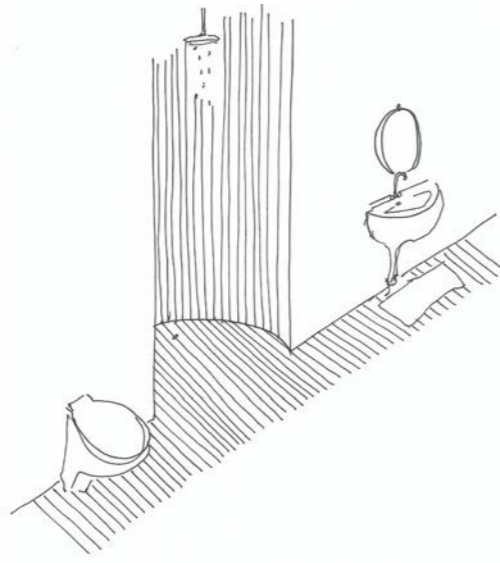

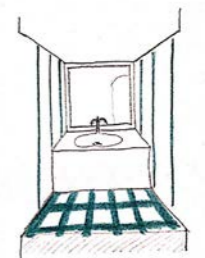
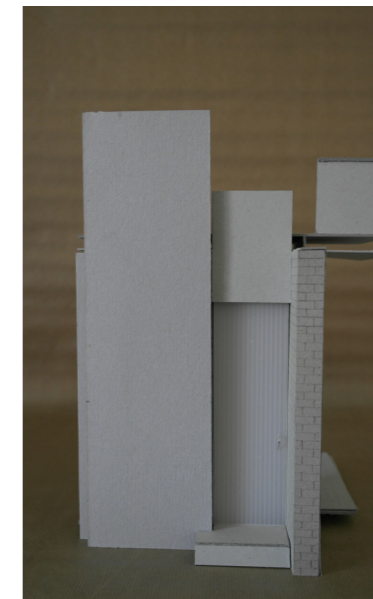
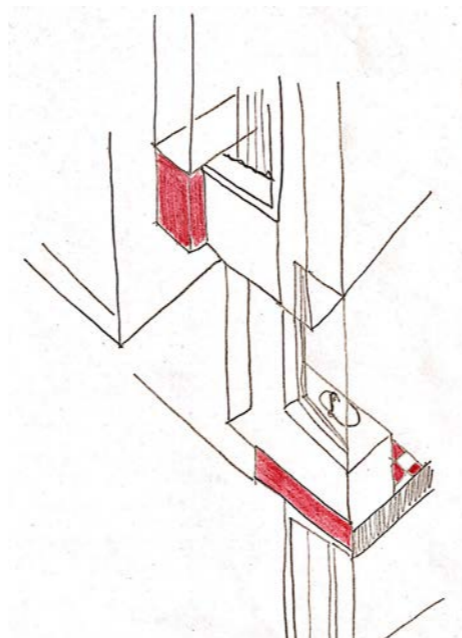
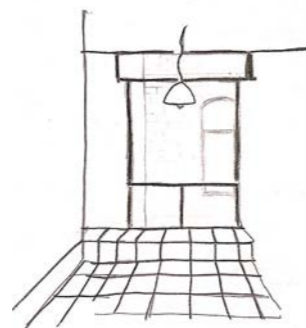
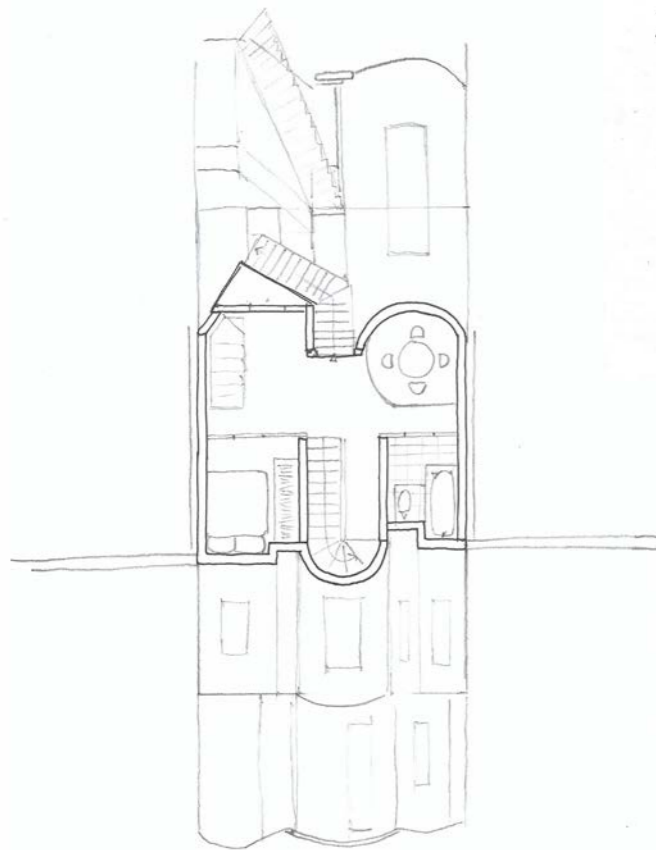
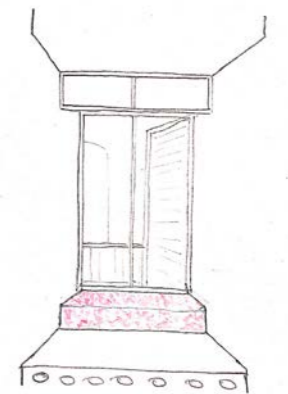
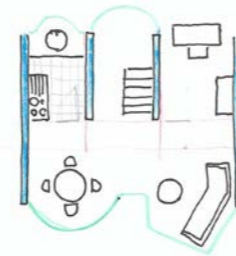
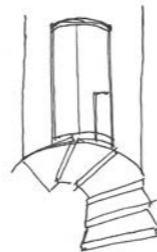
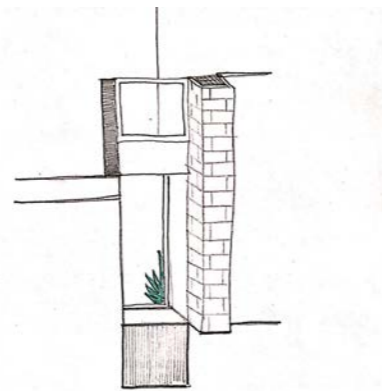
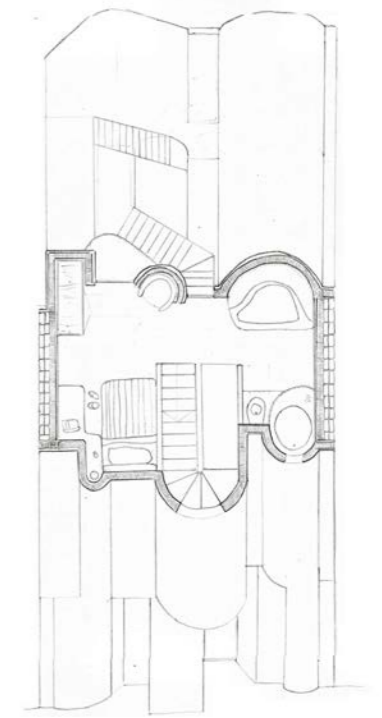
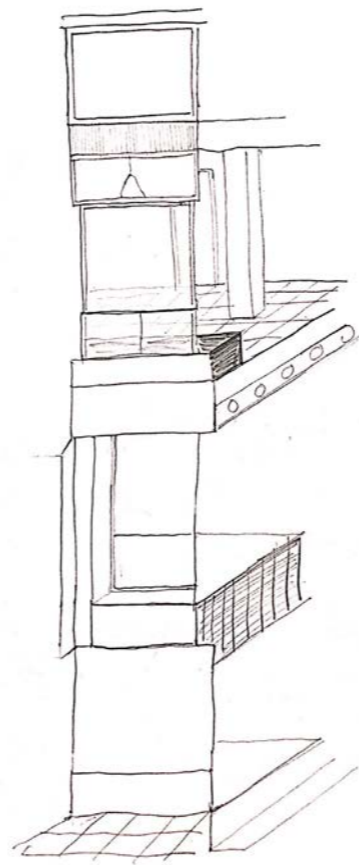
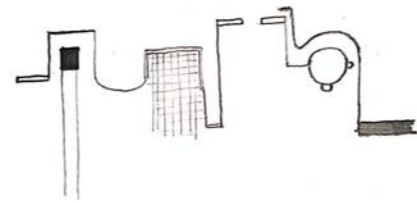

A

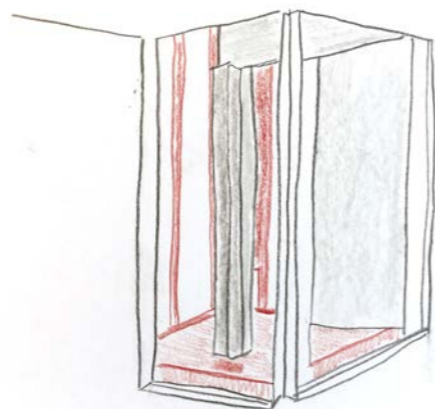
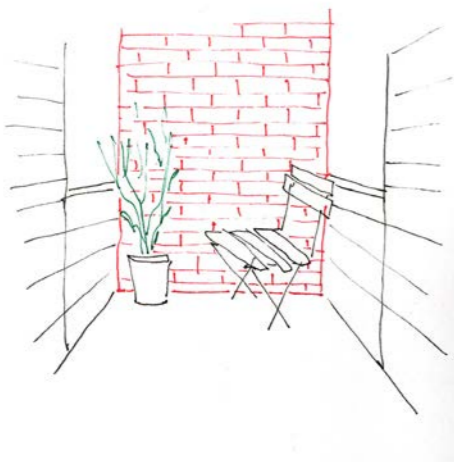
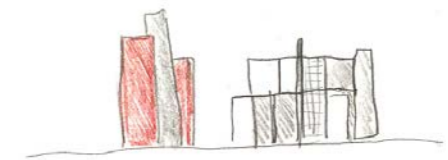
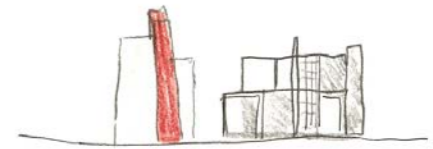
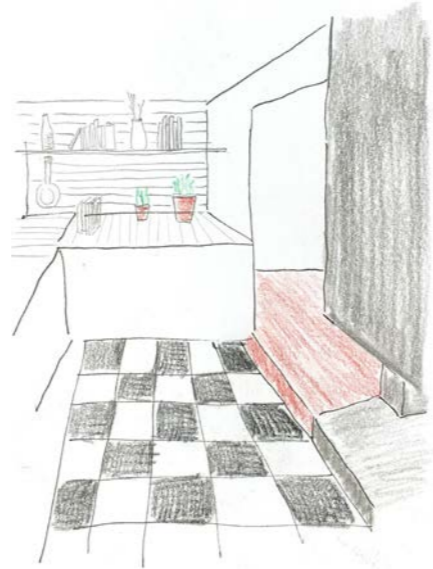
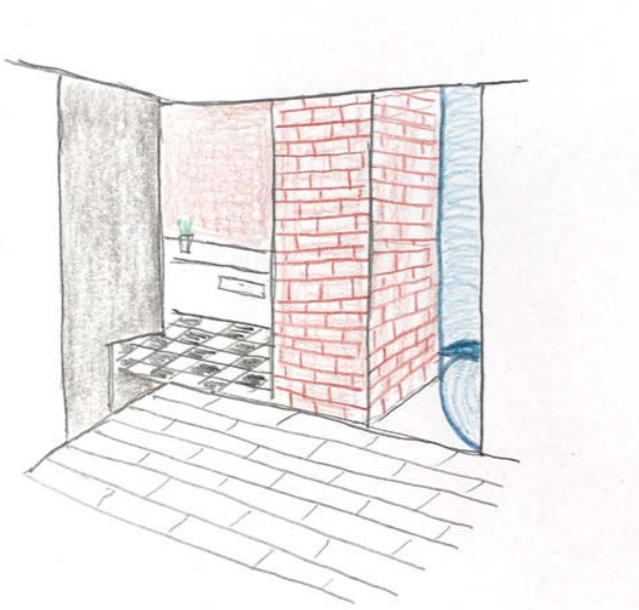
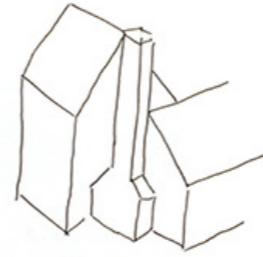
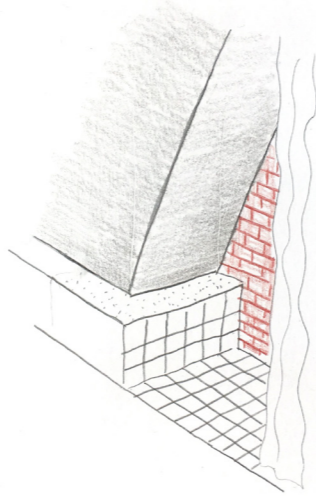
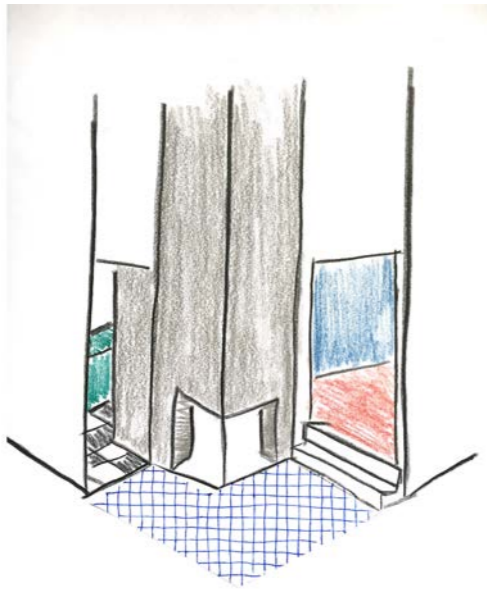

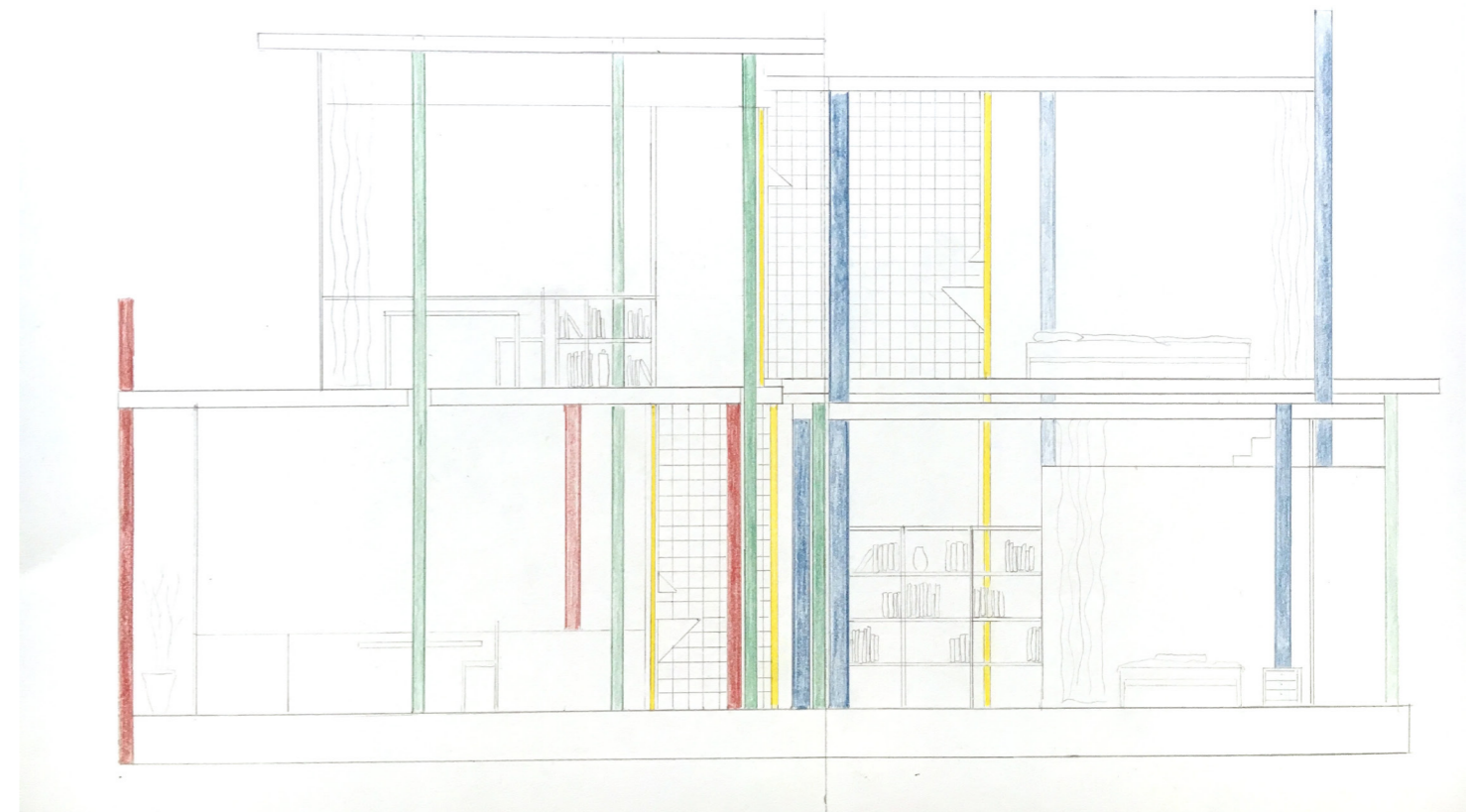
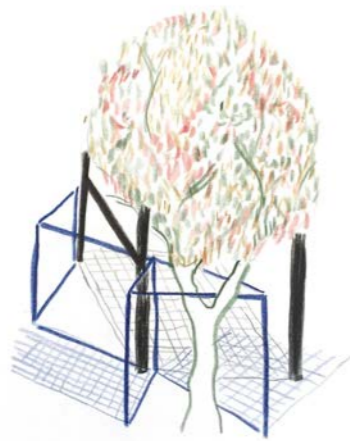
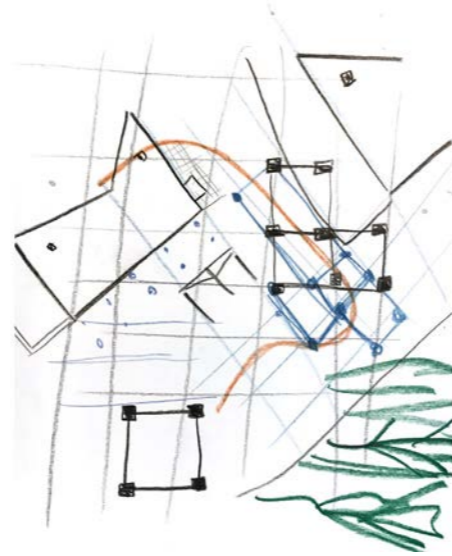
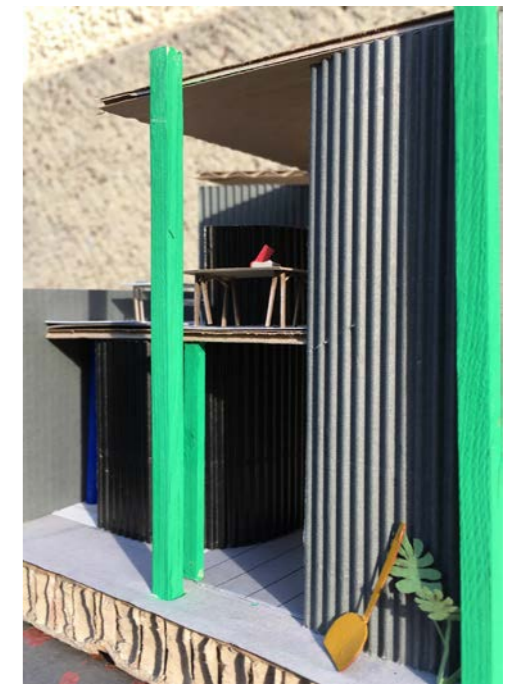
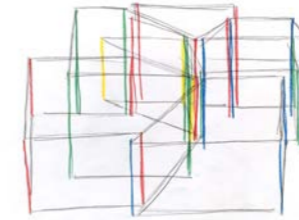
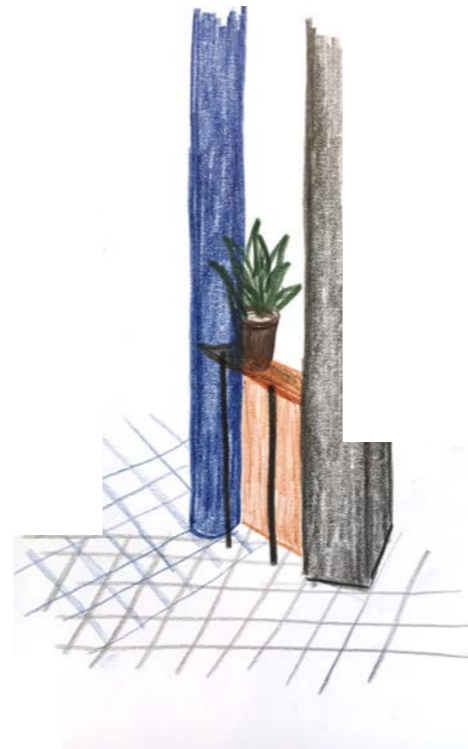
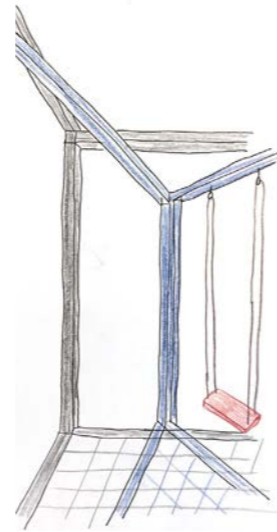
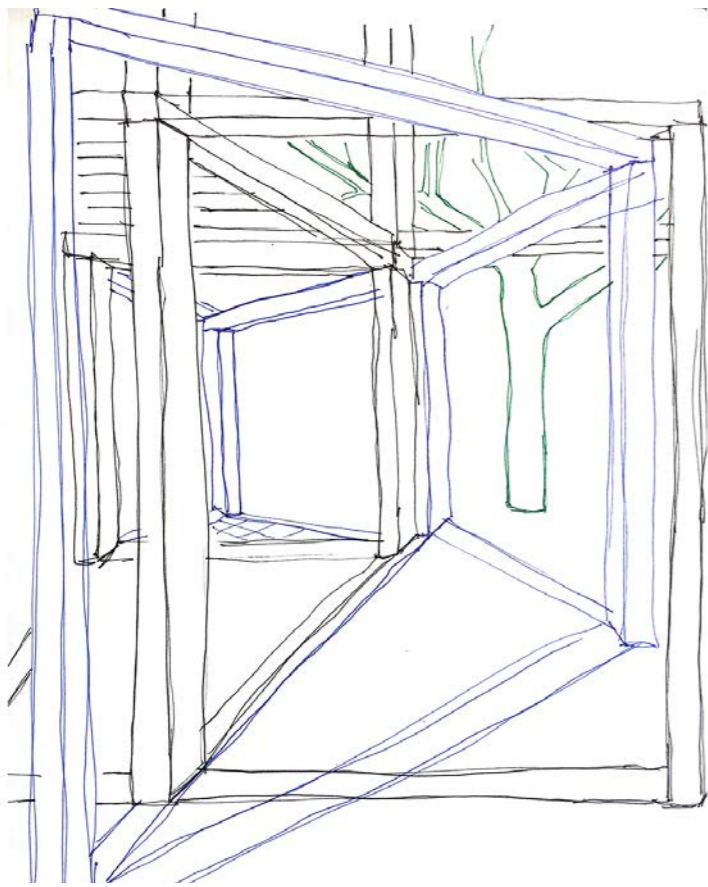

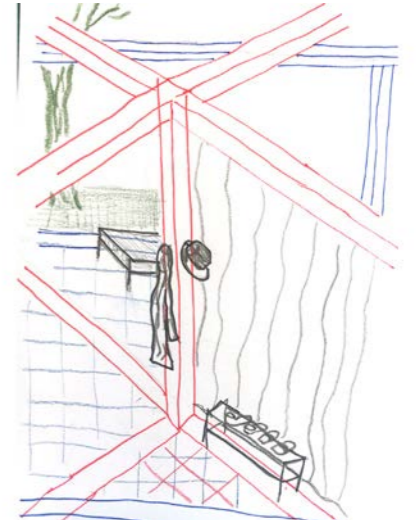
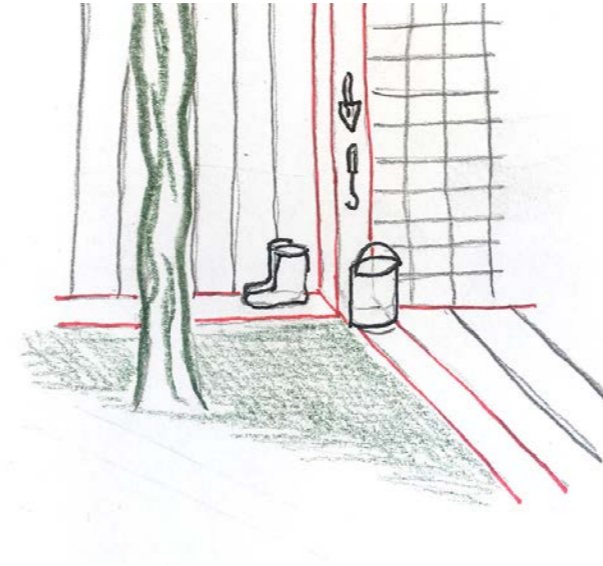
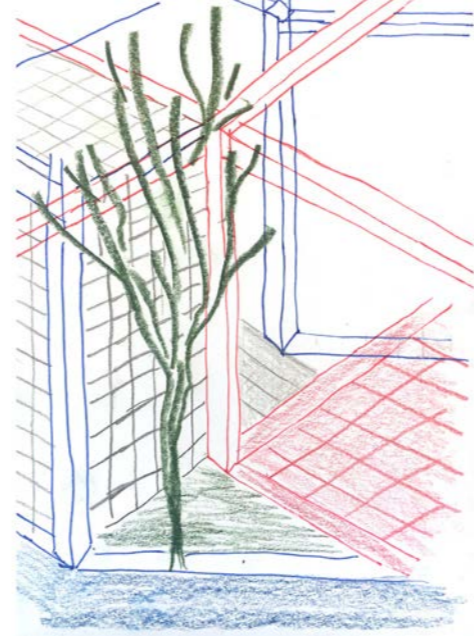
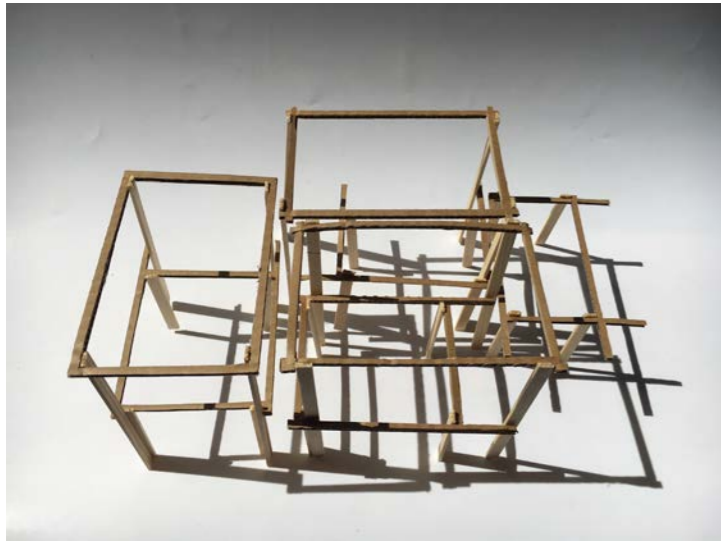

THE BEDROOM
COLUMN



THE BATHING
COLUMN

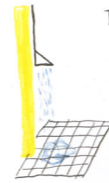

THE KITCHEN
COLUMN



THE LEISURE
COLUMN

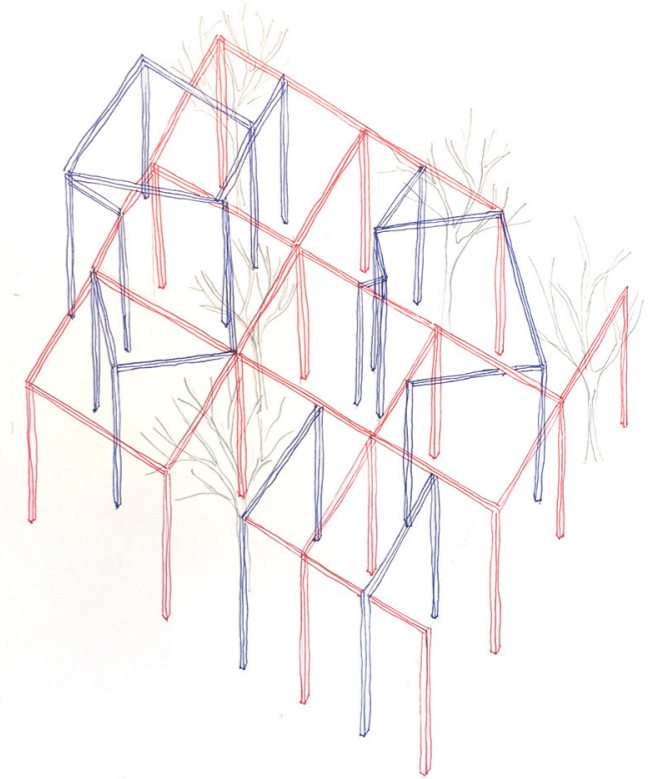
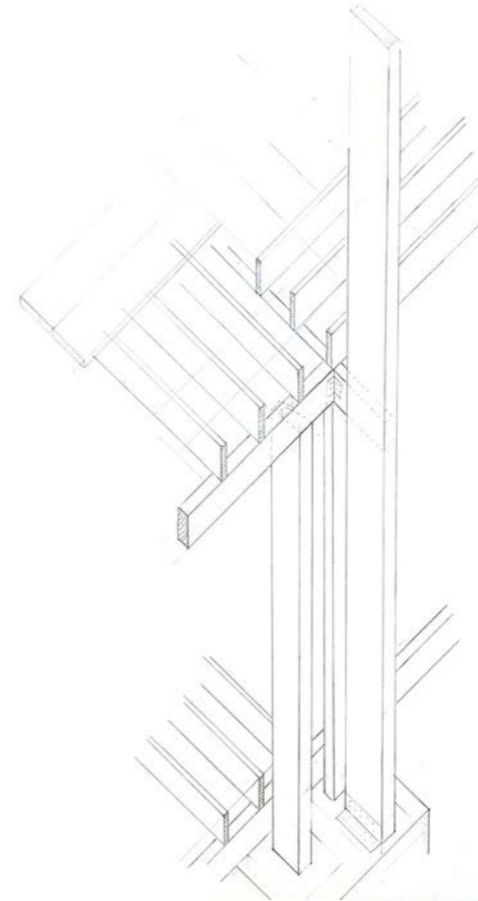

A

