

universum carrousel journey
re-practice prac-teach – a method
making meandering meaning – the studio
final review – spring 202

Natalie Hase

Charlotte Reuse

Joel Zimmerli

universum carrousel journey – a studio
carrousel journey universum – a practice
journey universum carrousel – whatever
Studio Jan De Vylder
ETH Zürich D-ARCH IEA – FS 2020

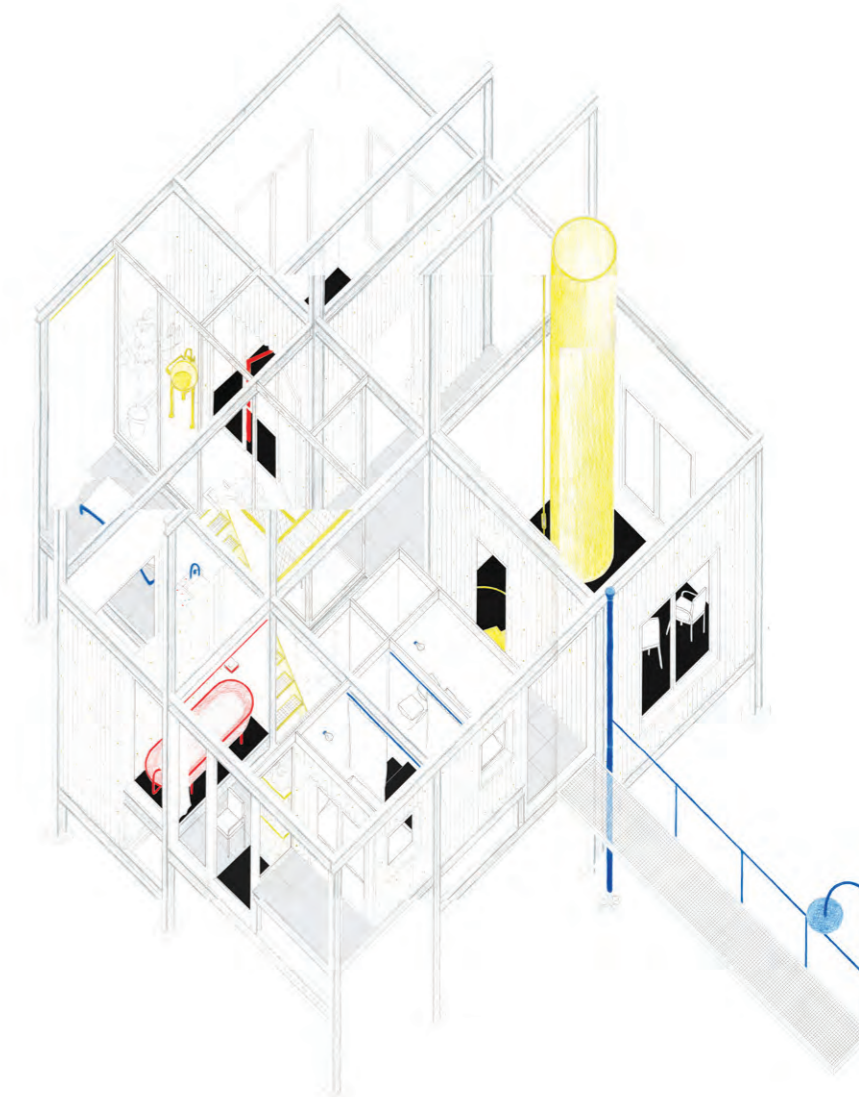

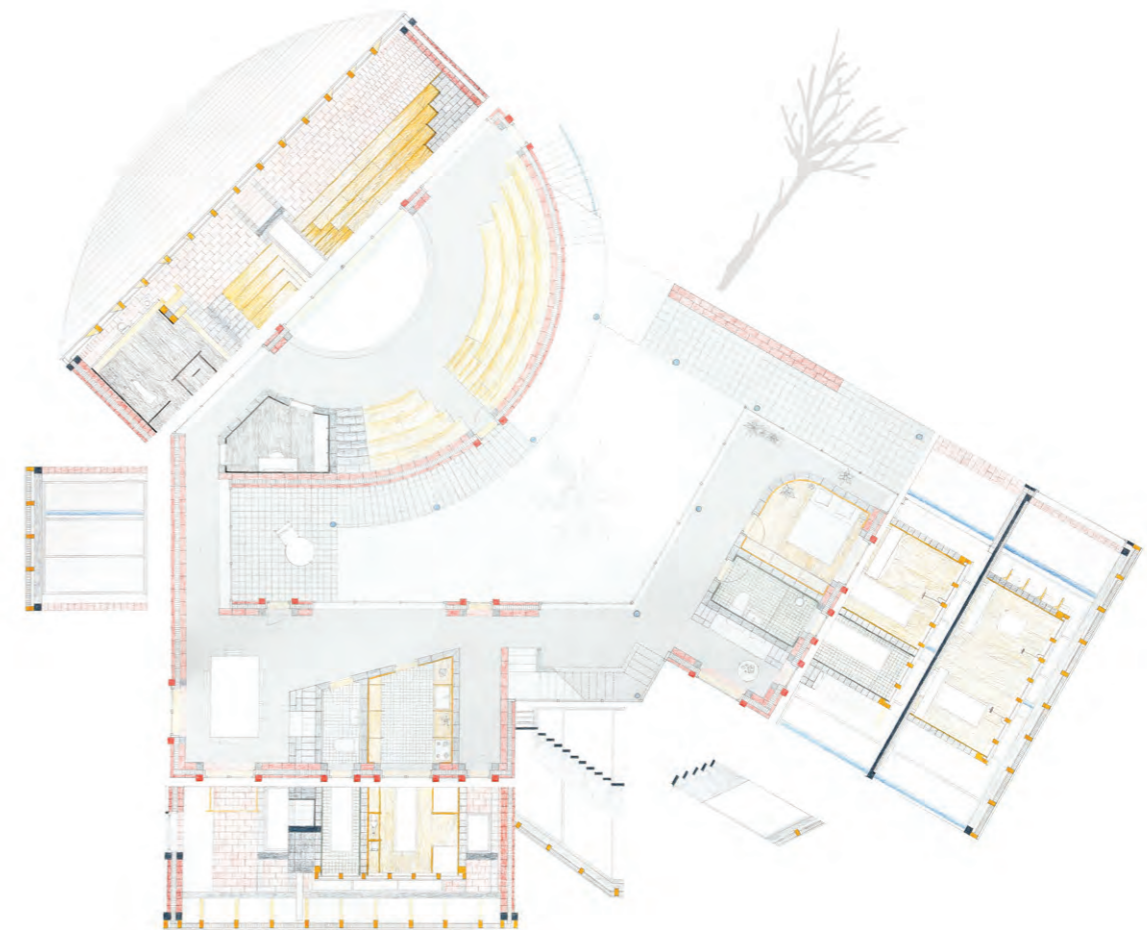
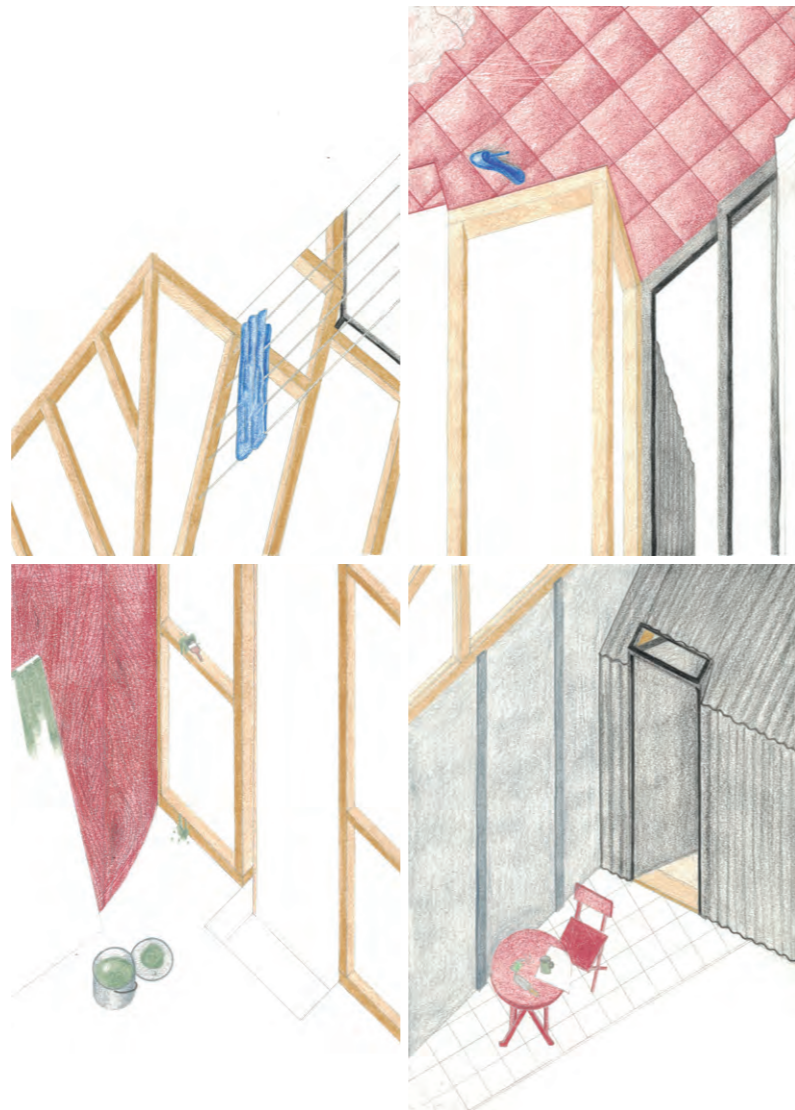
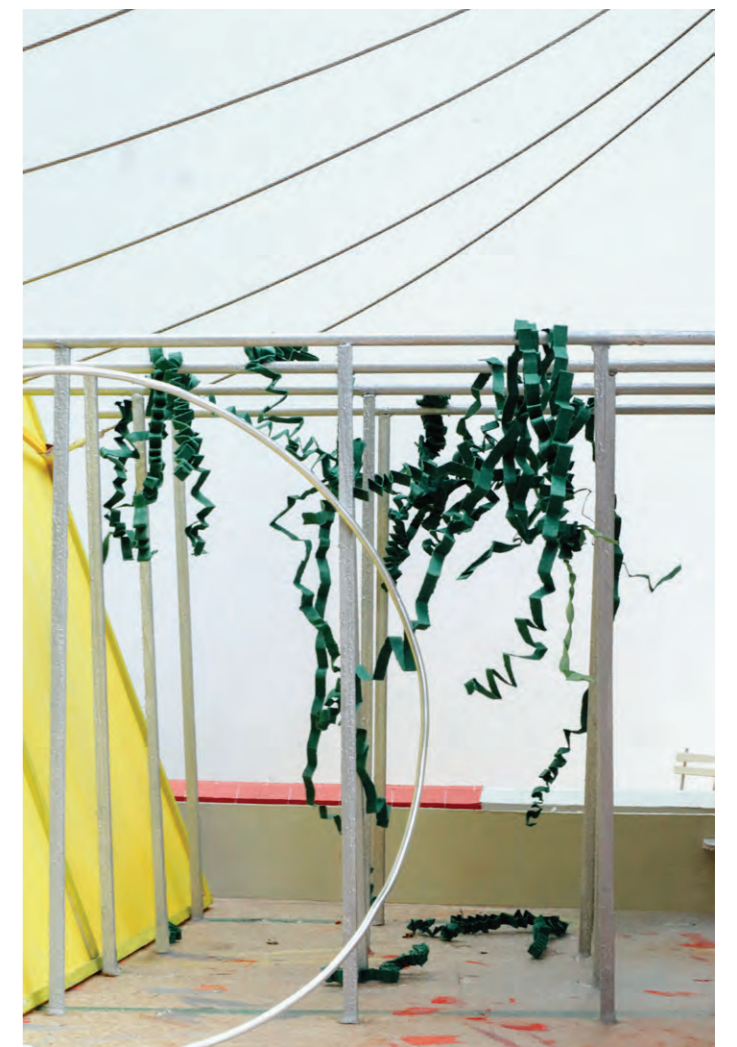
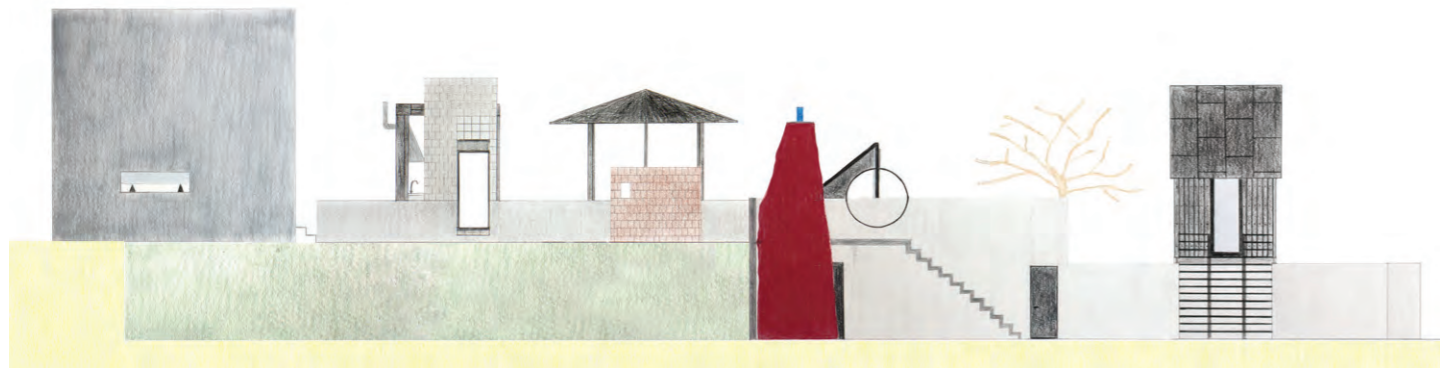

Movement 1





Scene of the Everyday

On this Saturday afternoon, everything is quiet at the de Wachter House. One can hear the sound of the wind in the trees. The sunlight is brightening the pink. It looks like an «about to melt ice cream». Sitting in my office, i can see the rays of light coming from the multiple windows, and moving along the cold floor . The movement of the curtains reflects in these spots of light. Their delicate danse is an invitation to join them in the breeze.

A head goes by the glass bricks. Noises of small footsteps on the tiles.
Clac-clac-clac-clac-clac.

I put my pen down, sip the last drops of coffee in my cup. Talking by the window gives me this strange feeling. Warm - Cold - Warm - Cold - Warm - Cold - Warm - Cold - Warm - Cold.

I am in the corridor. The light here is aquatic. As in the office, the light moves around, shadows of branches, the danse of the curtains. It keeps moving as i walk up the stairs. The light comes now even from under my feet.

I hear footsteps again.
Clac-clac-clac-clac-clac.
I open the brightest door. I suddenly feel overwhelmed by the warmth of

the sun, and the breeze caressing my face. I look down. A yellow spot on the pink. My partner sunbathing. It feels like the perfect spot.

1 1:20 Model Picture



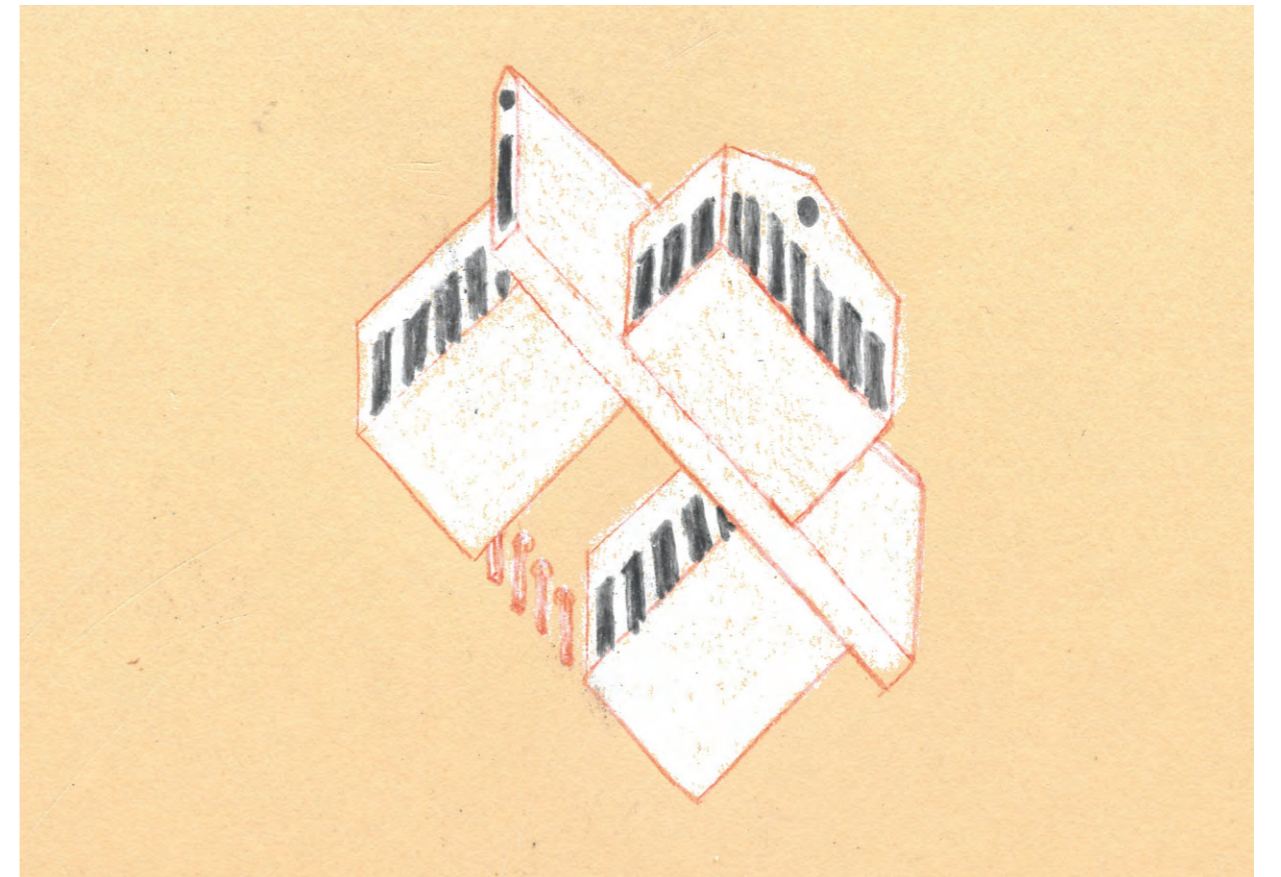
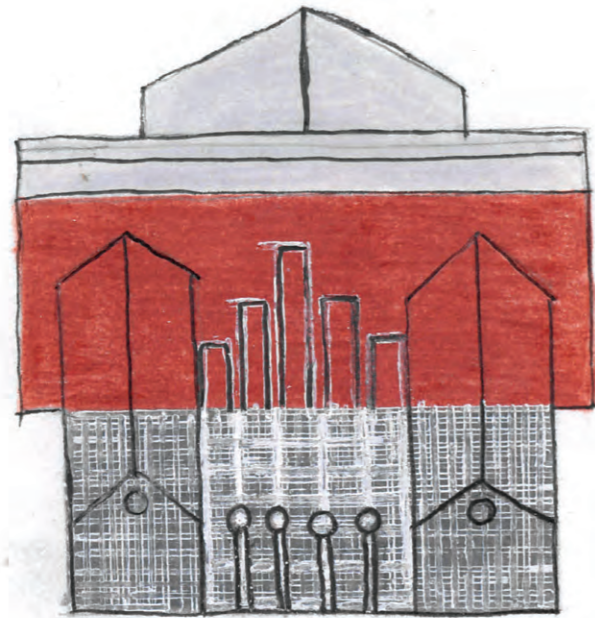
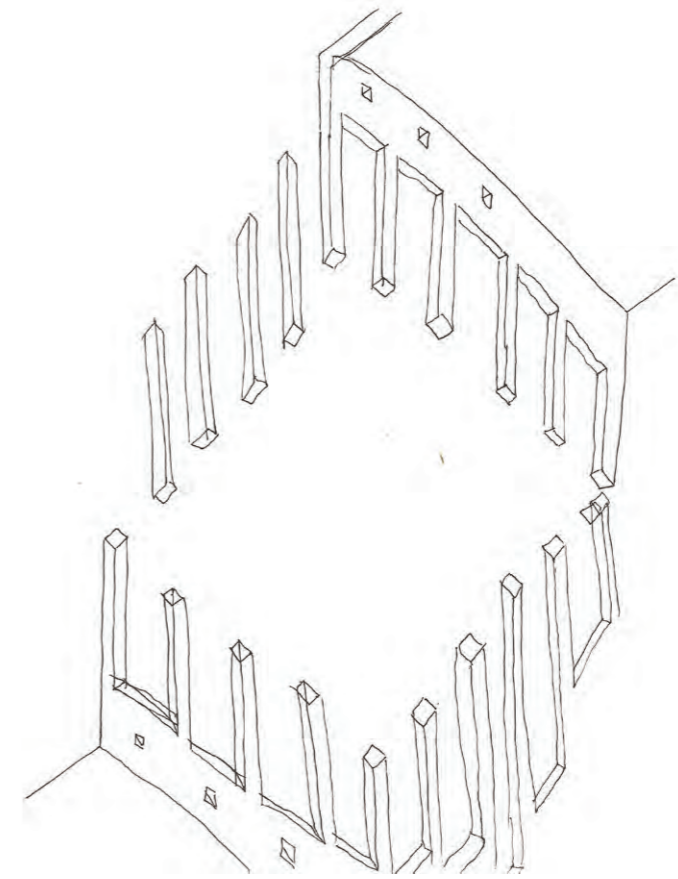

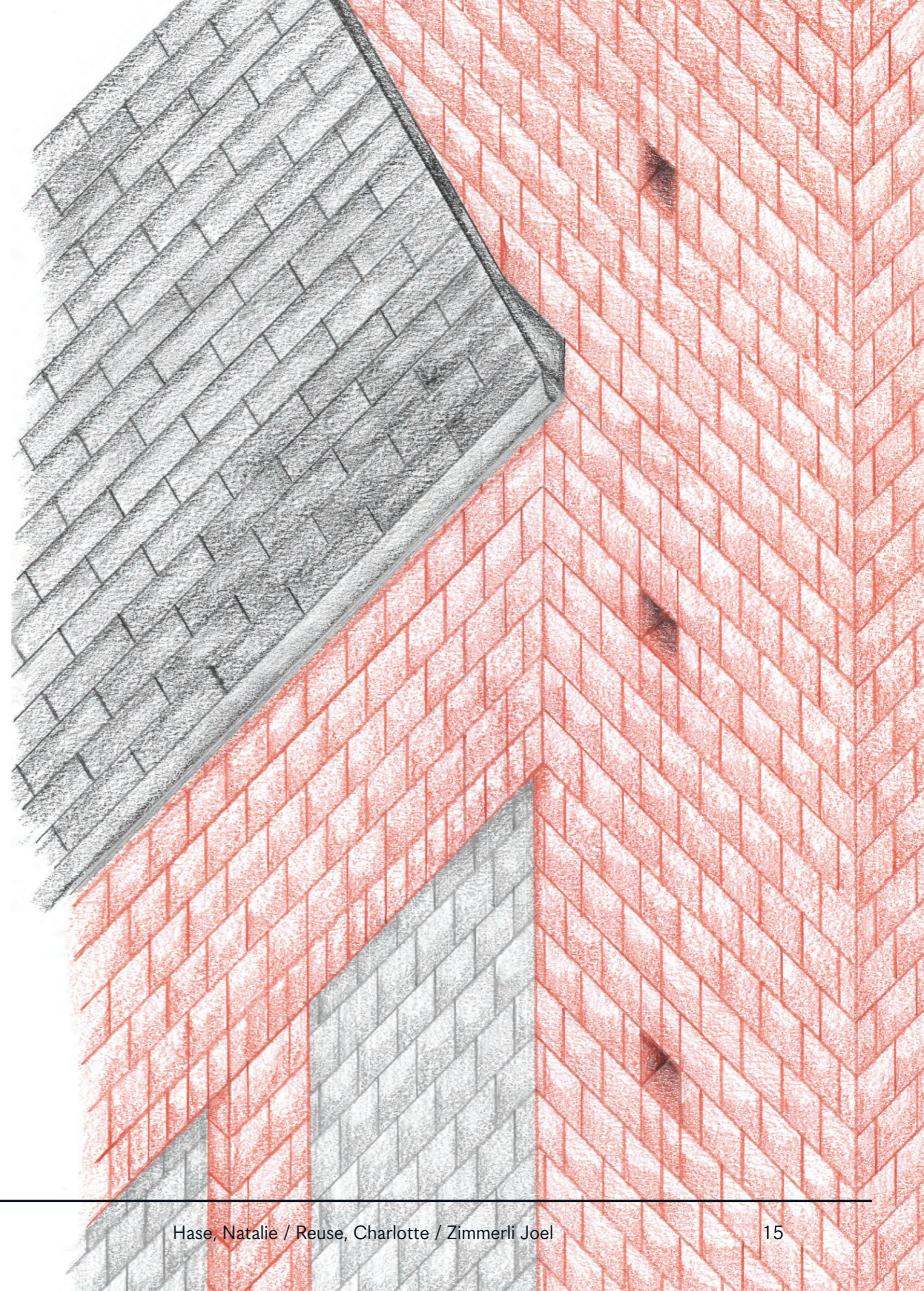
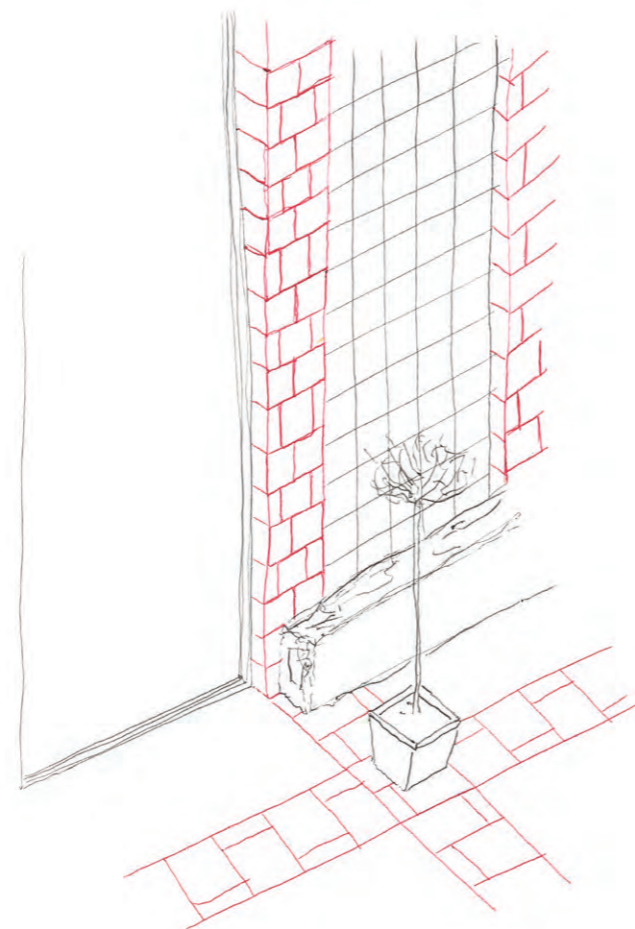
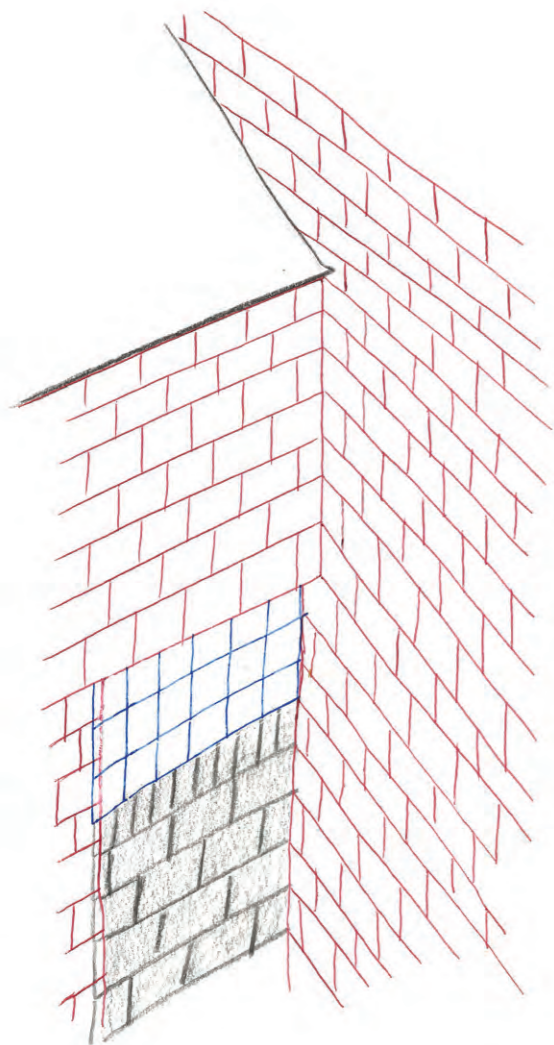

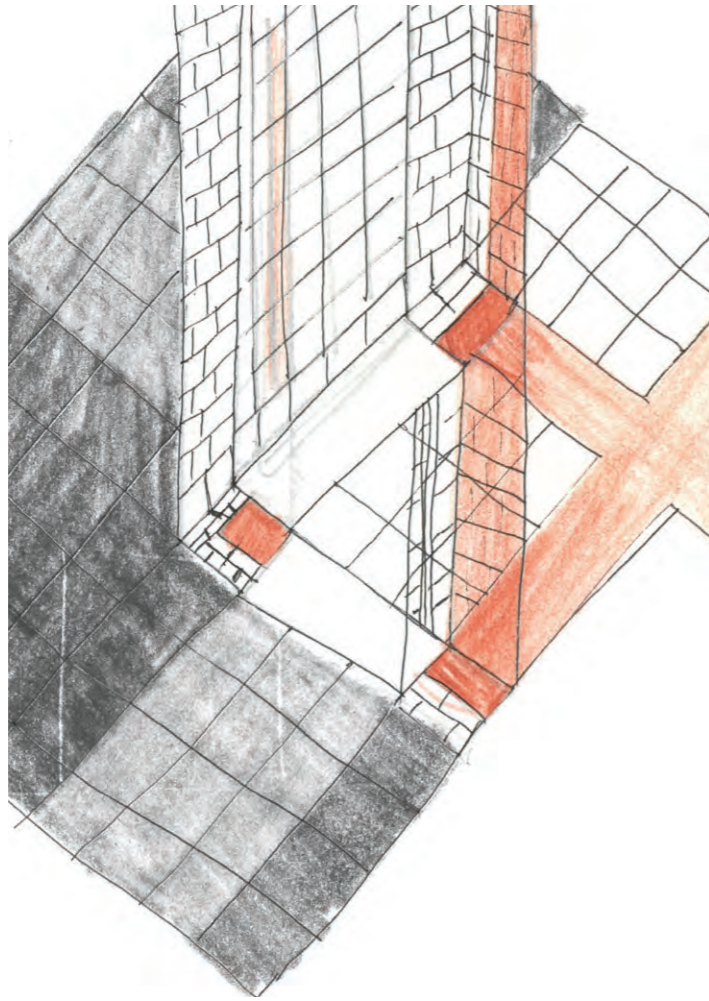

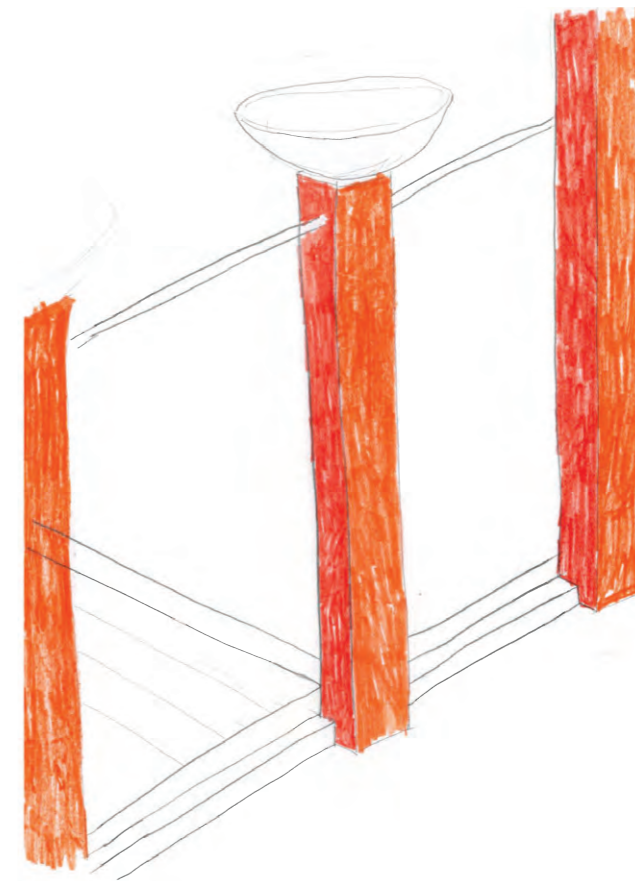
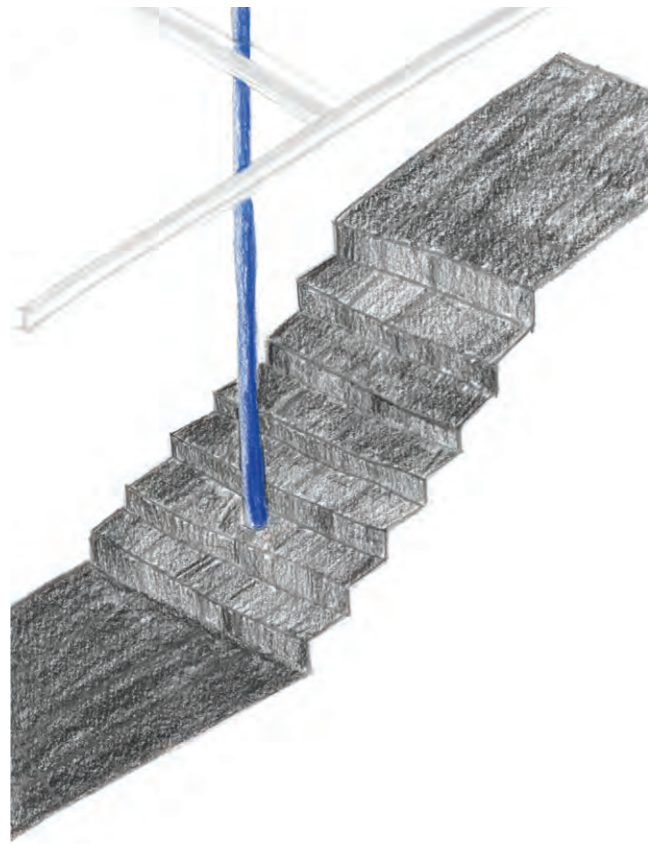
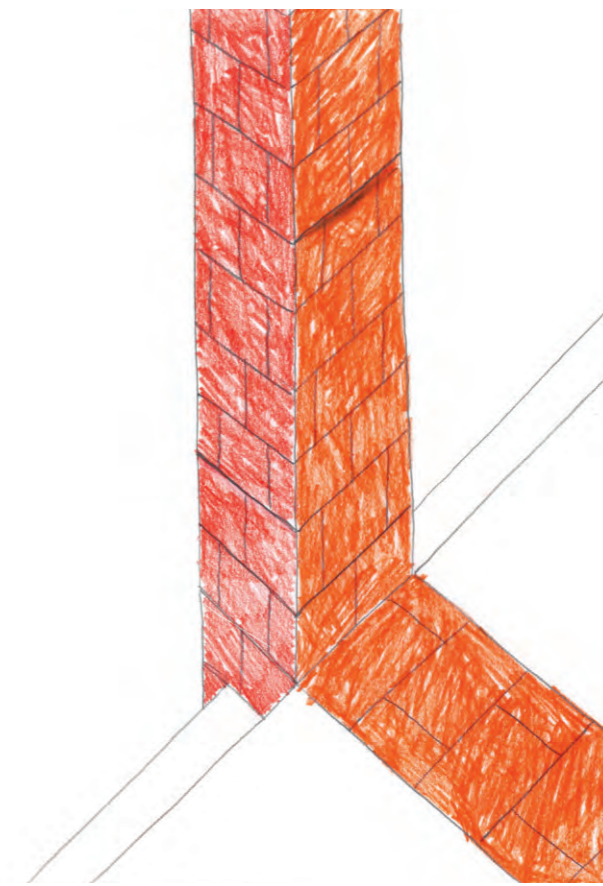
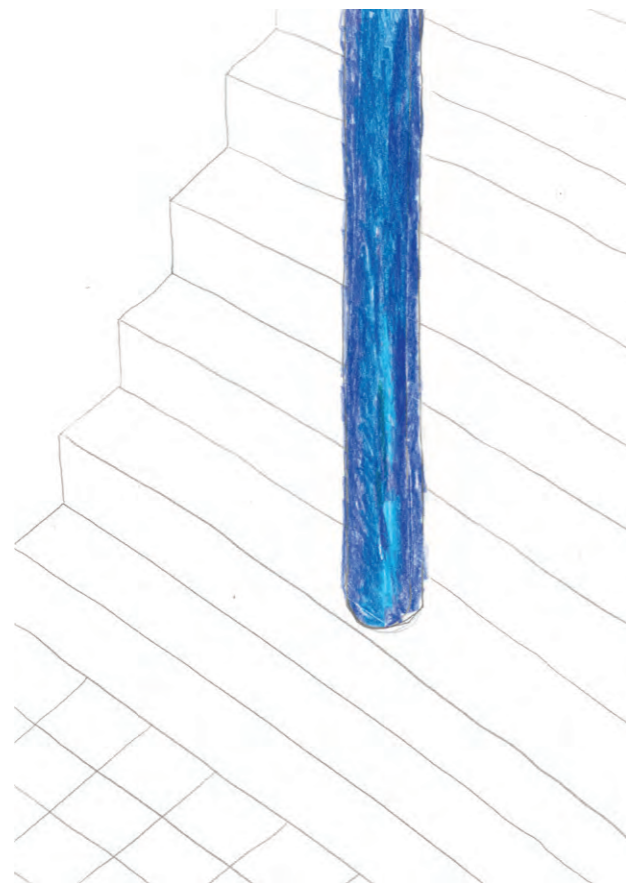

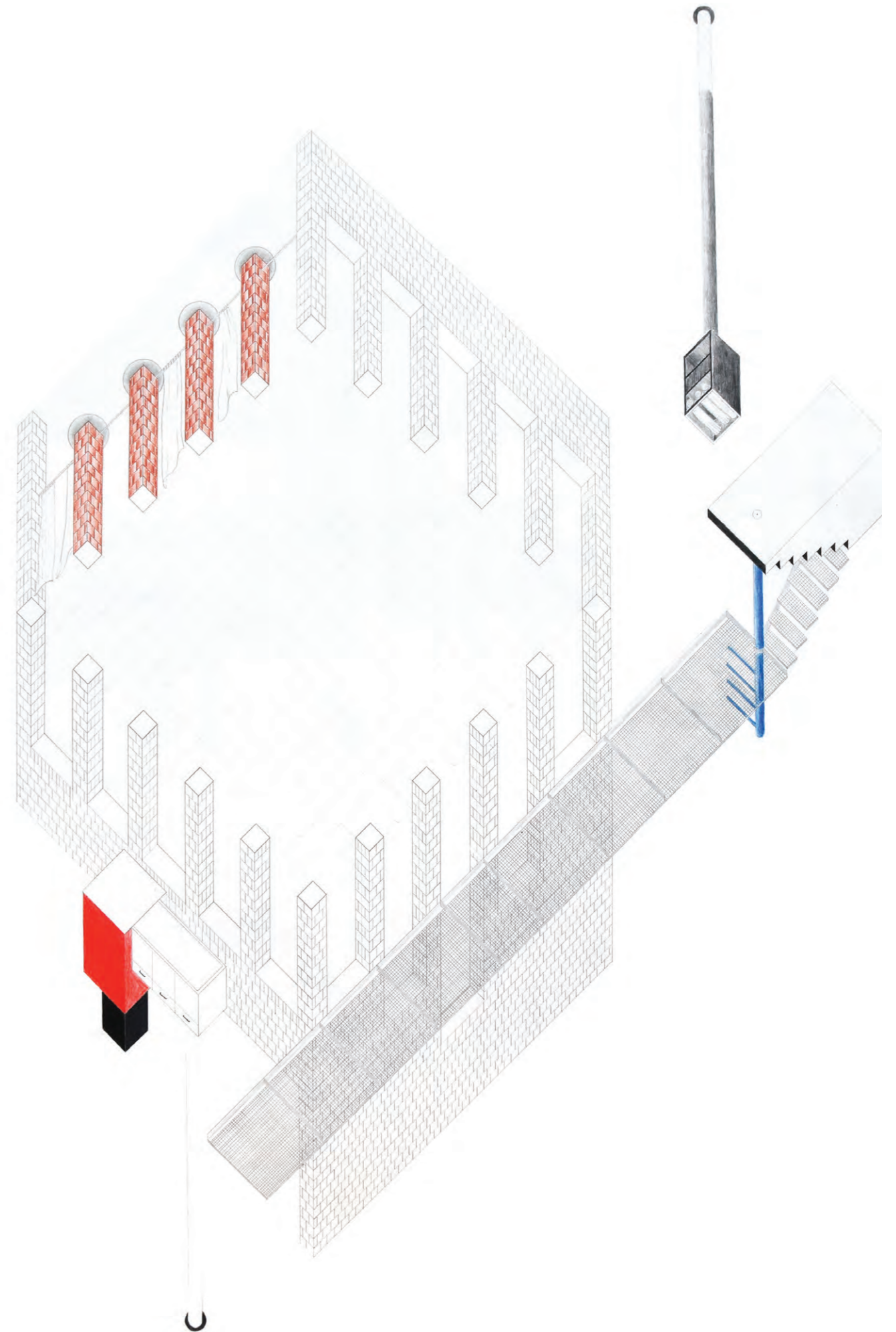
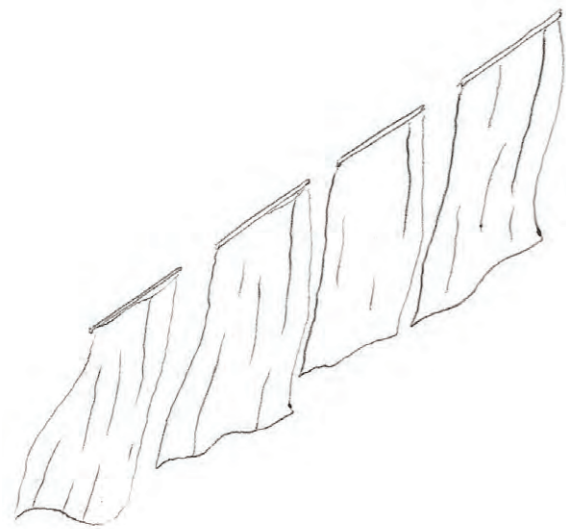
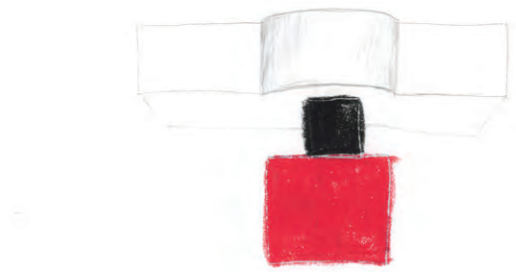

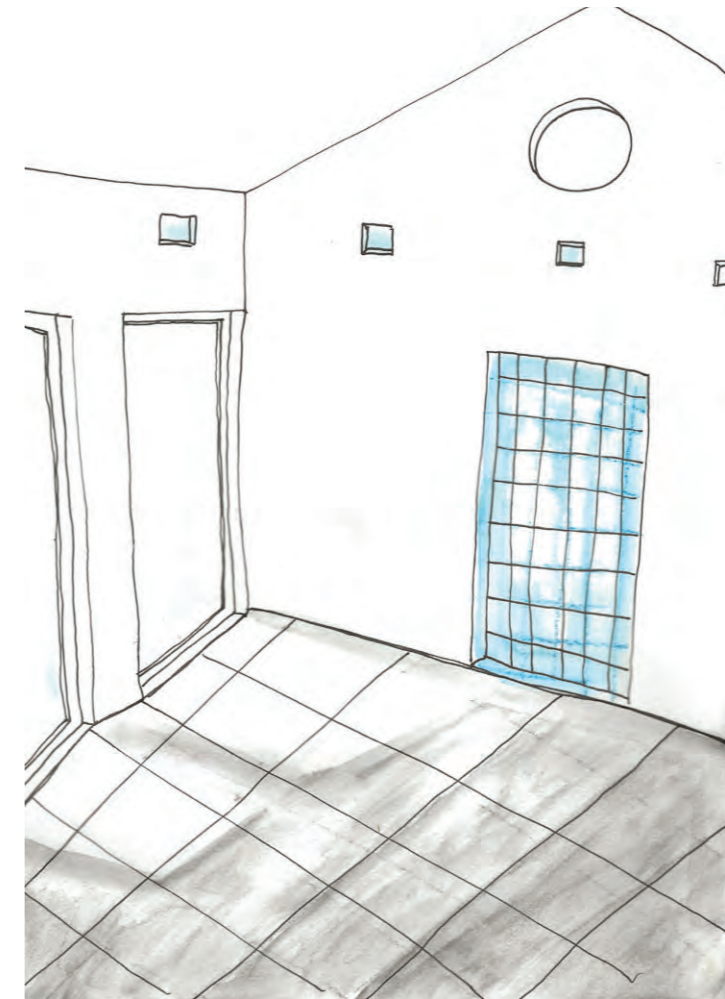
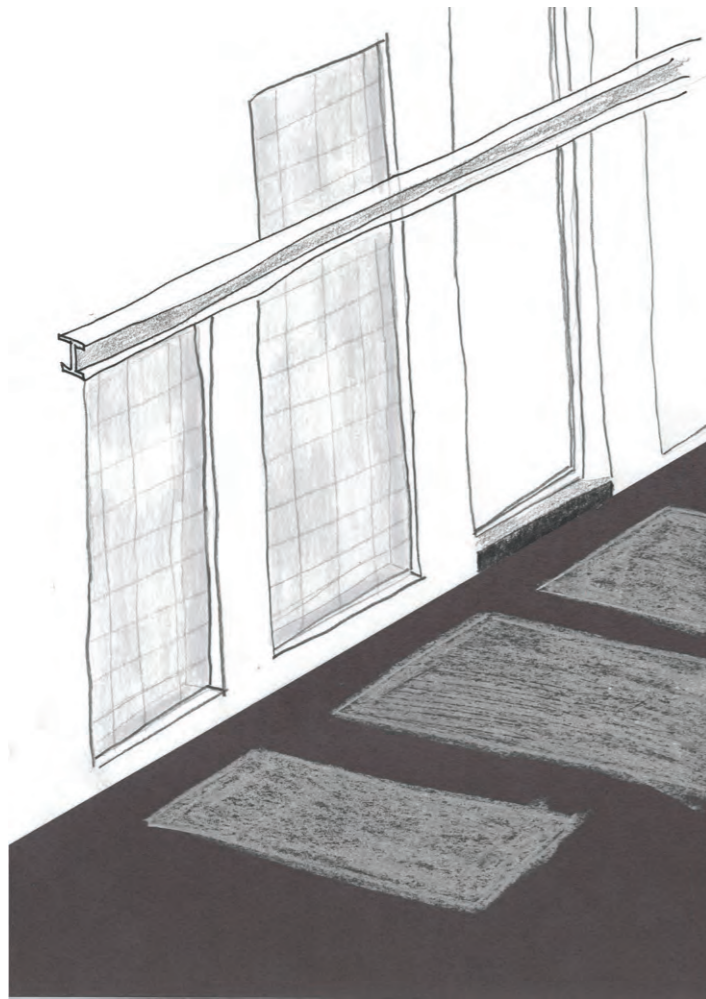





Movement 1





My summer breaks

The art collector lives in a house in Therwil. I spend most of my school breaks together with him.

If you want to visit the art collector and park your car, he can open the large gates and let you in behind the wall in front of the house. This is what the art collector calls the outdoor cinema, the movie screen is the high wall of the basement. We can just park the car in front of the wall and watch the movie from inside the car. One time the neighbor also parked his car next to us. From the outside you have no idea if there are many people looking at the movie or just me and the collector, because of the high wall all around it.

There is a very, very narrow stair leading up to the garden from the outdoor cinema. But it can be difficult to find, and for some even hard to get into. What most people don't know is that they actually don't have to climb any walls or stairs to get to the garden. From the backside you can just walk right into the garden. Sometimes even the cows stroll into the garden when they're let out from the meadow.

As some parts of the façade are wooden it is possible to dry your swimming clothes on it, and it dries

quickly. The trick is that there are big enough round screws that work well as hooks for smaller wet garments, but the screws are very difficult to see from the street so it looks like if the clothes are almost levitating on the wall. Another good thing about the façade is that the art collector also puts his cigarettes in the façade from time to time. It is filled with cigarettes that are just as large as the width of a cigarette. But then, he sometimes forgets them and the next day or a couple of days later he can take them out again and smoke them under the roof glaring at the cows or the neighbors.

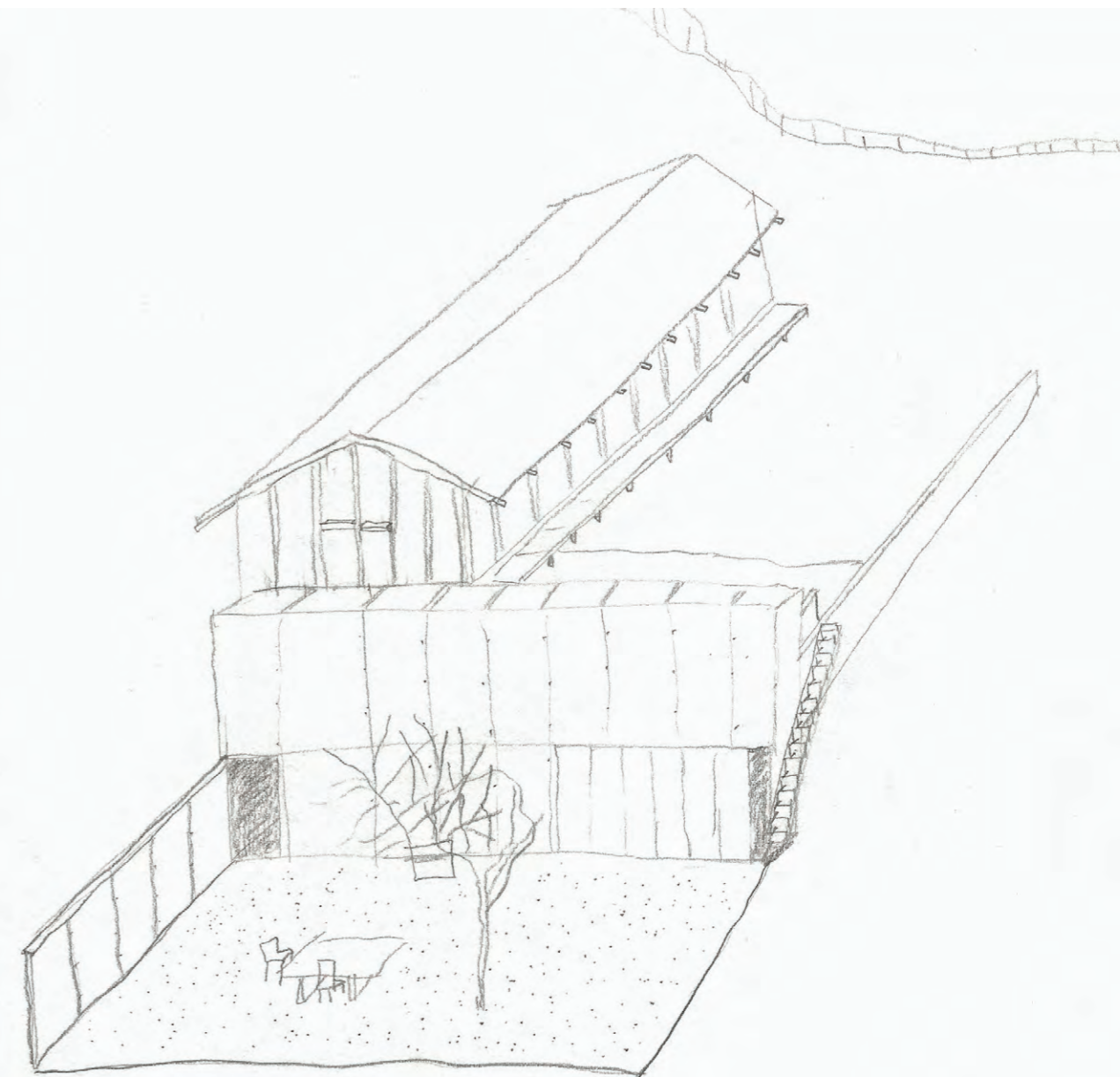

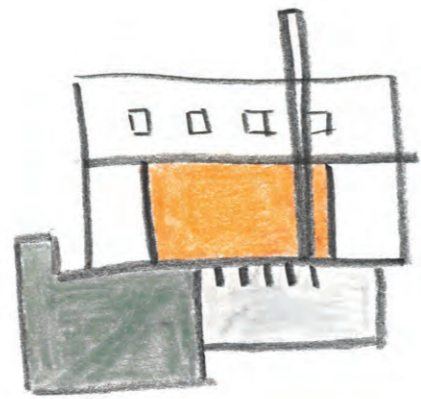
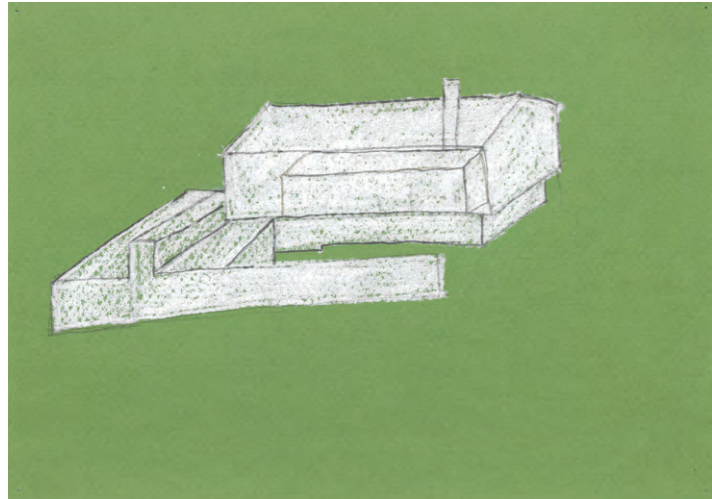

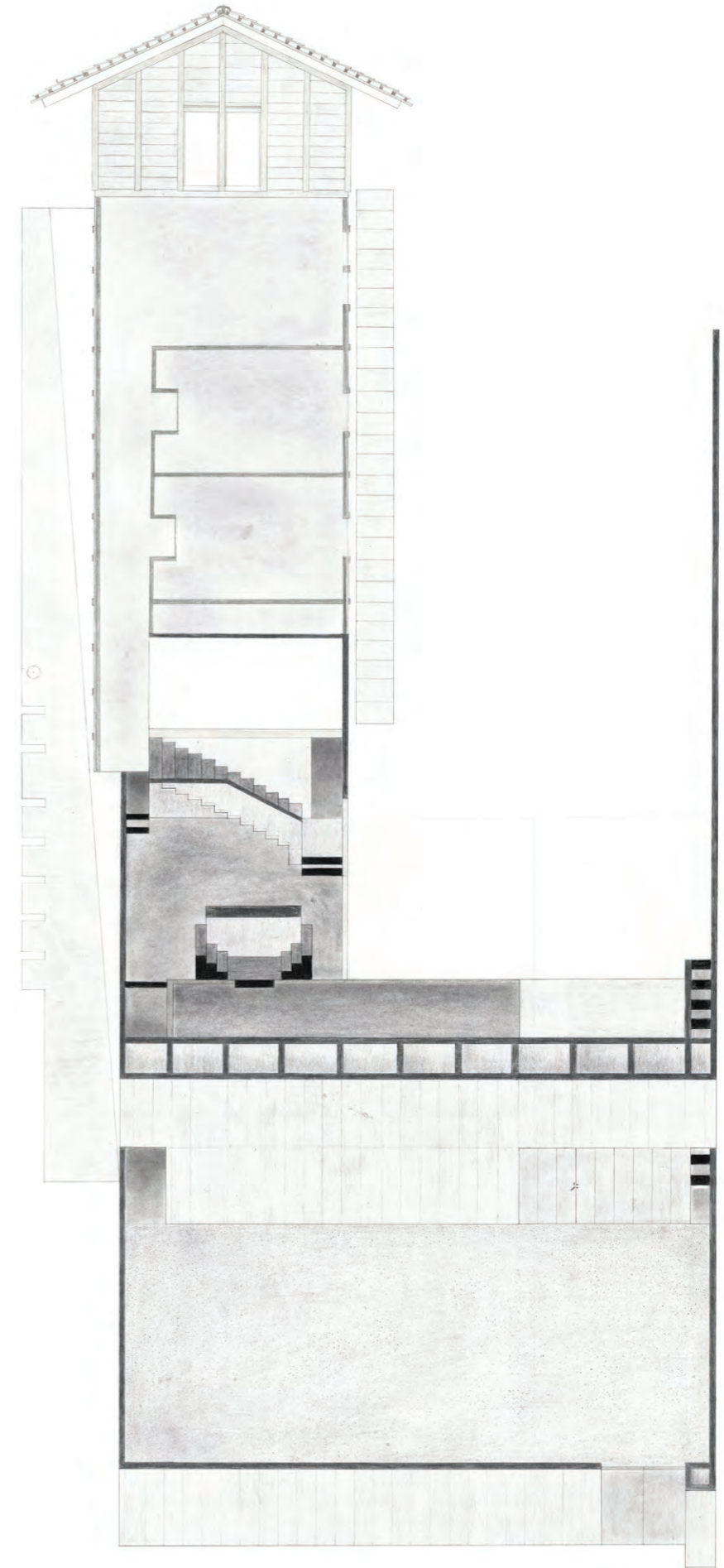

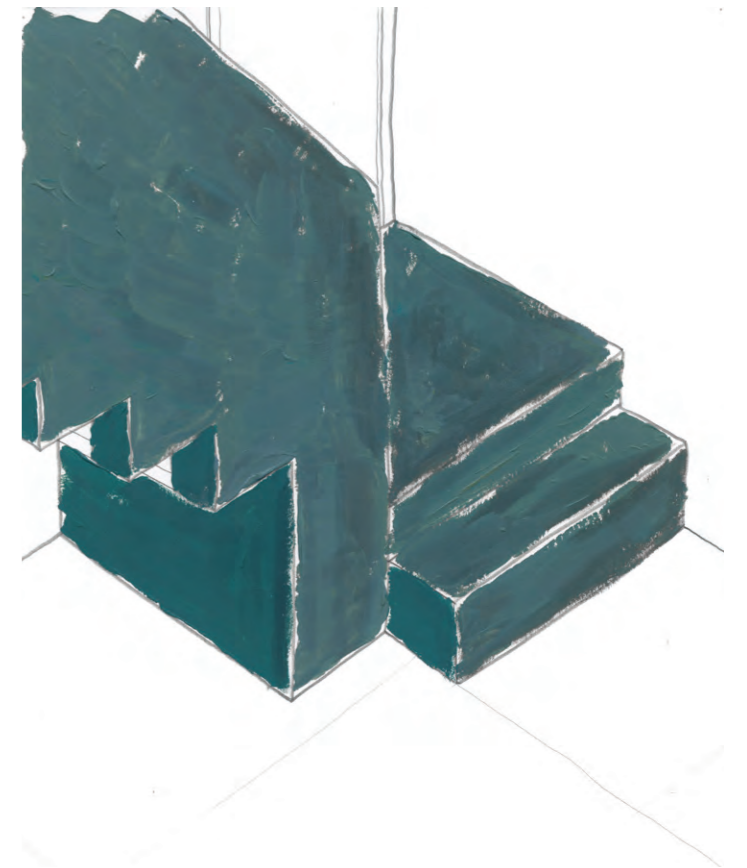



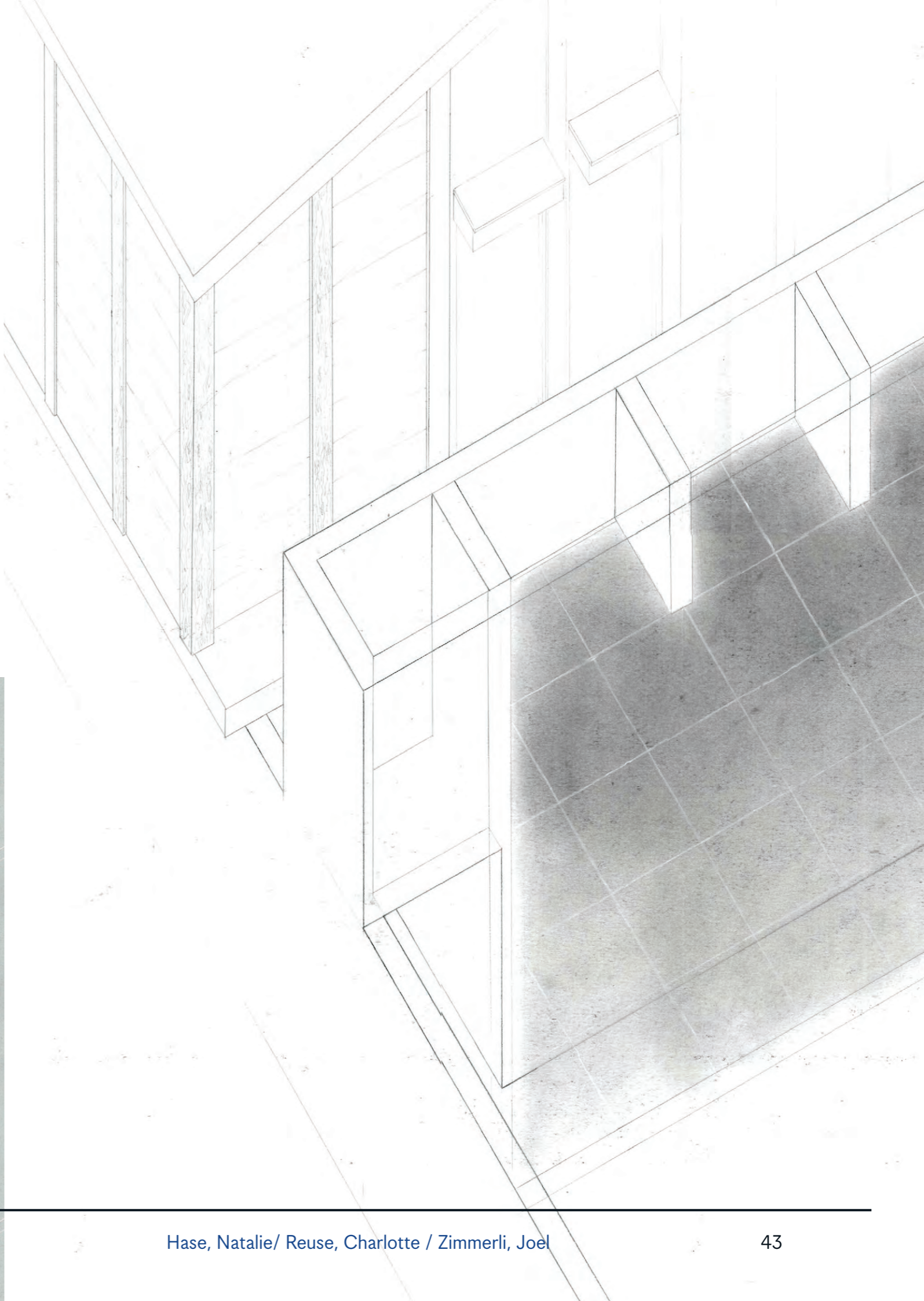
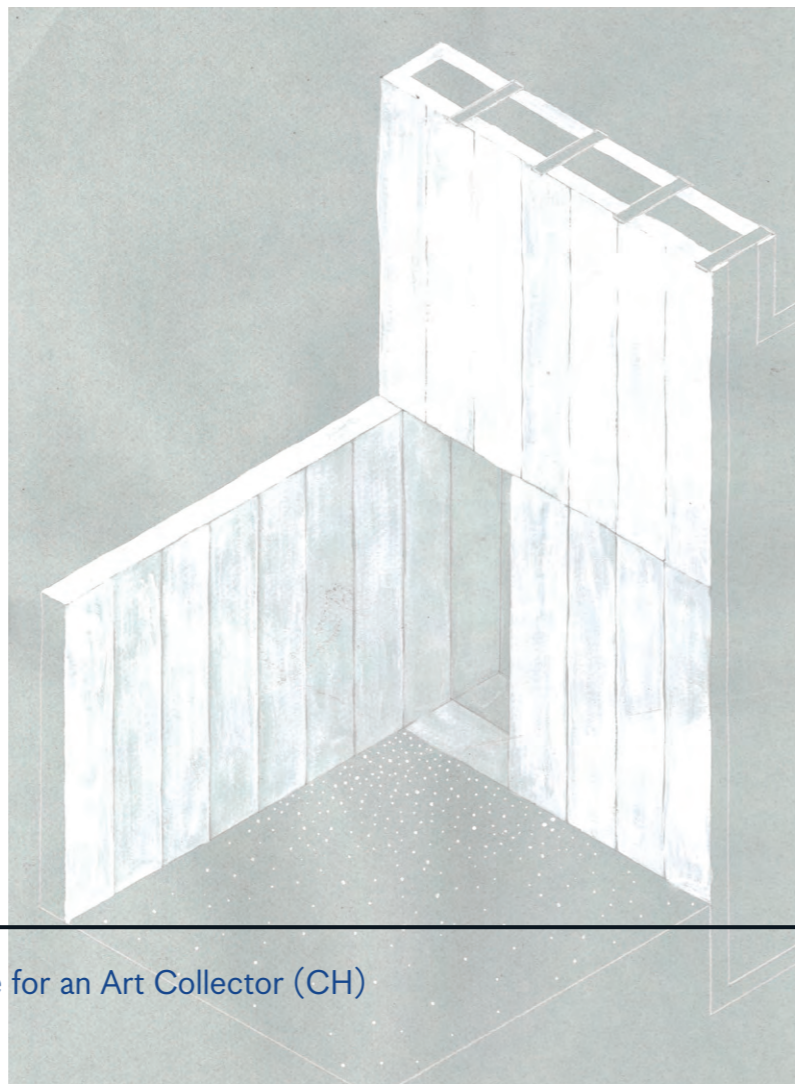
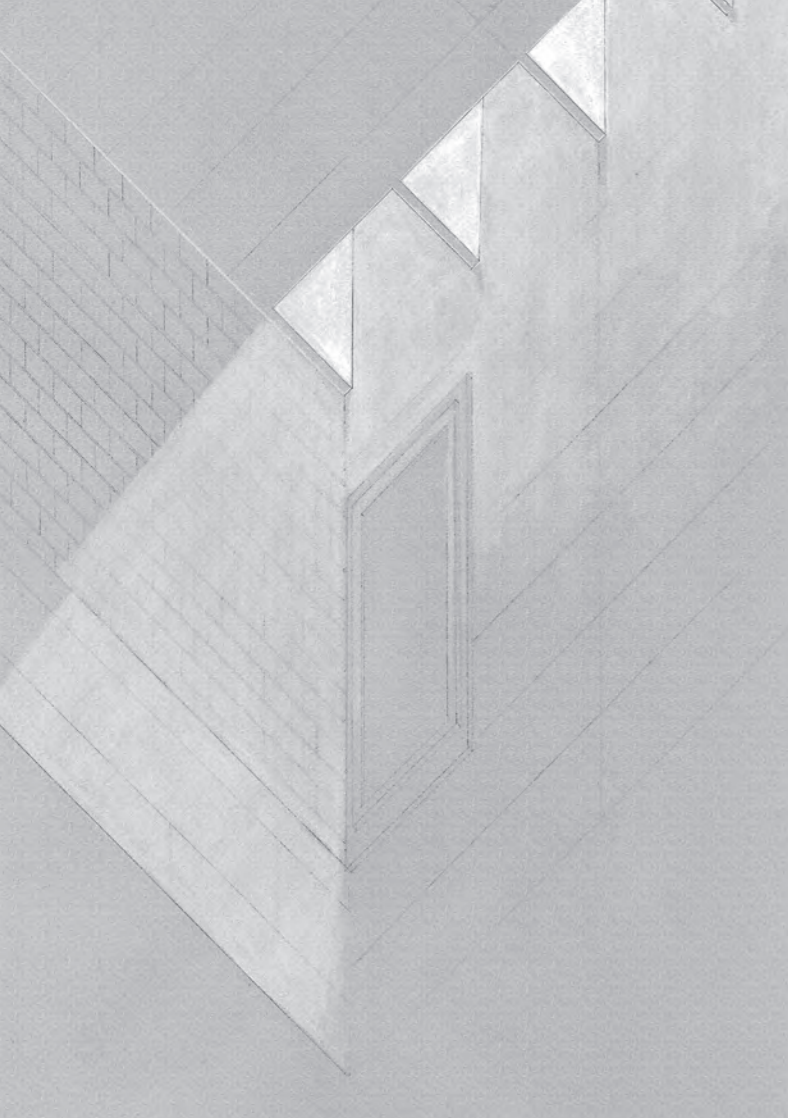

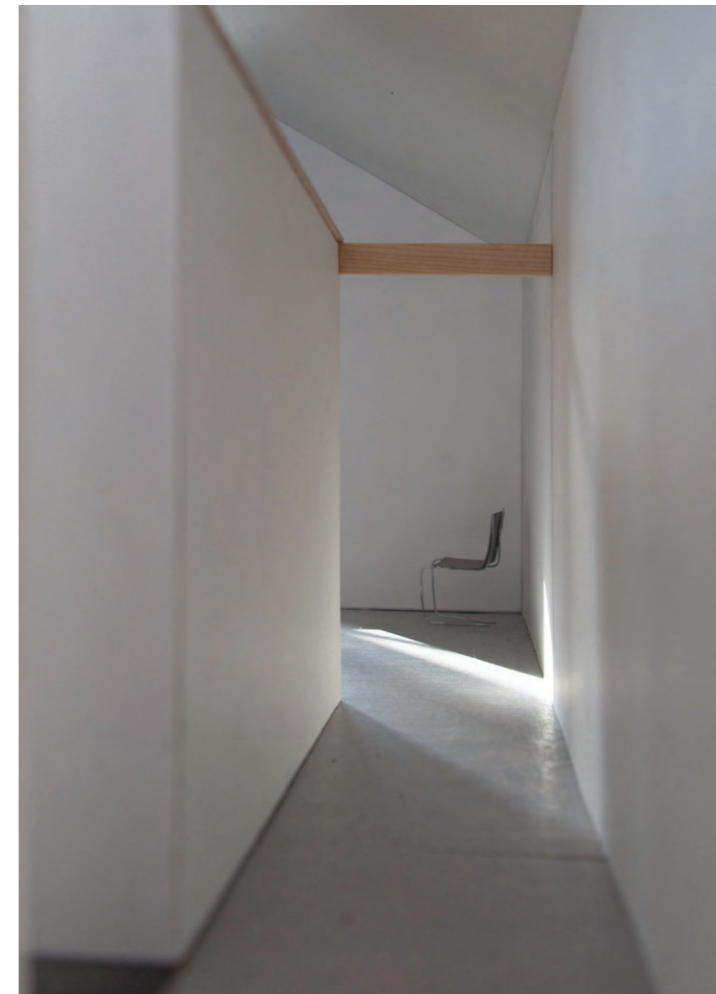
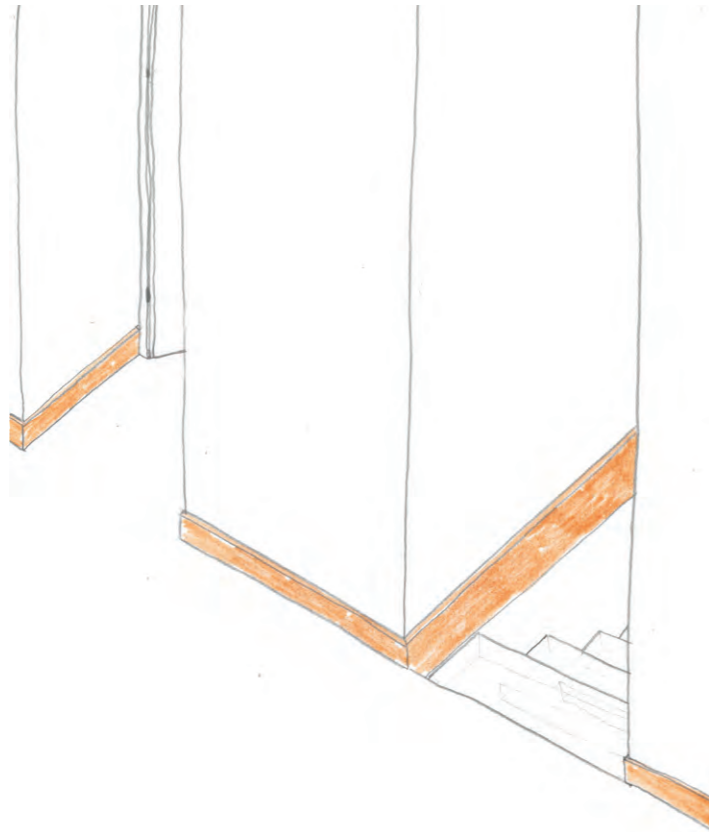

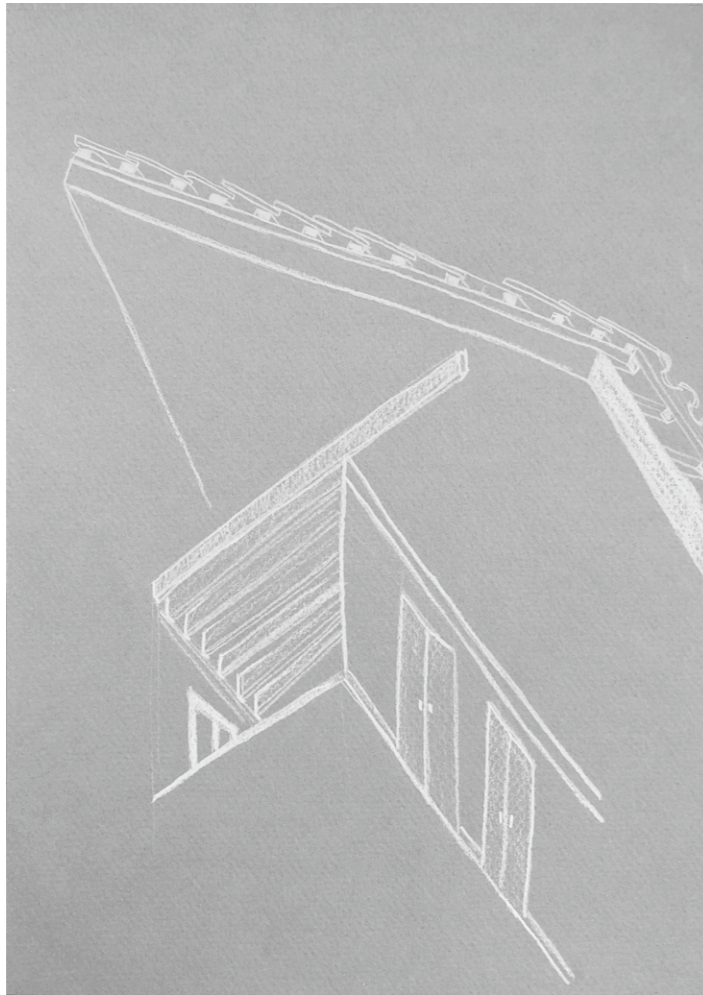

Movement 1



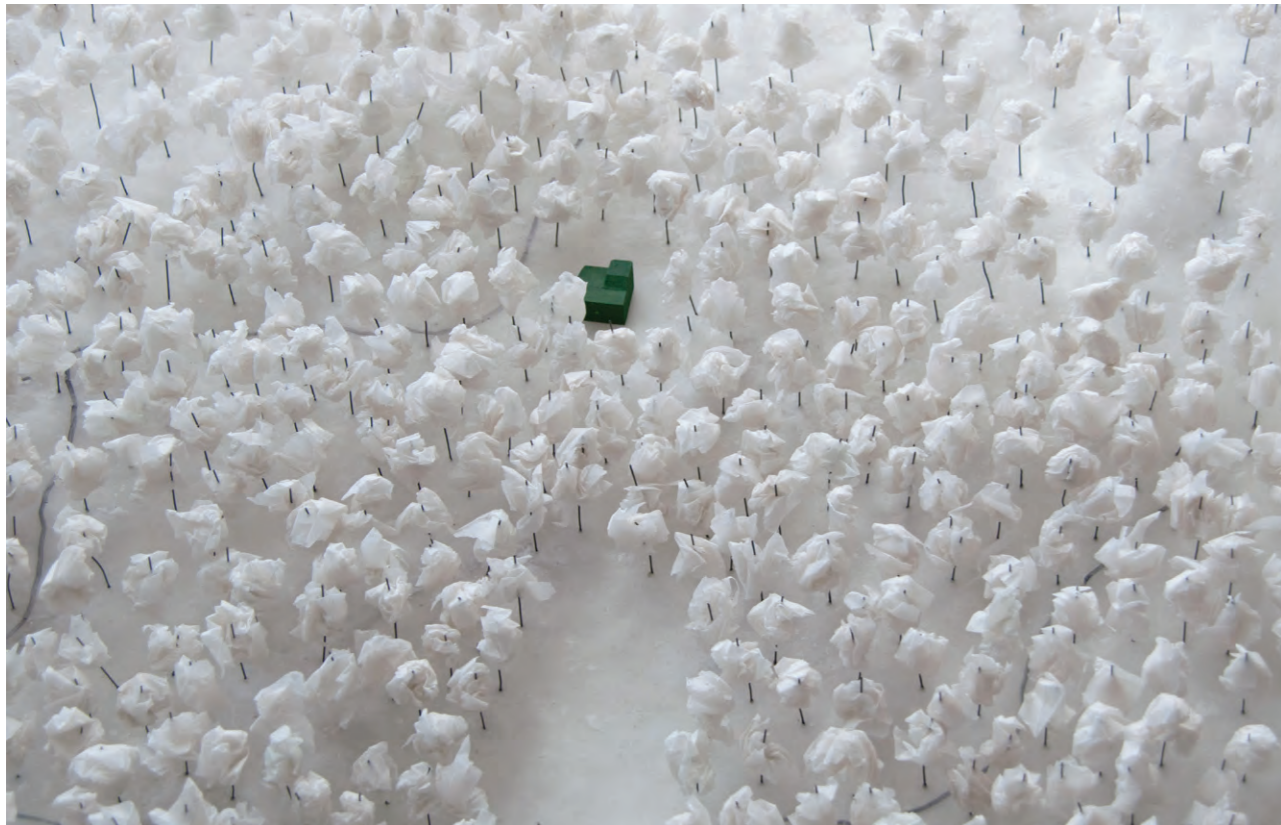

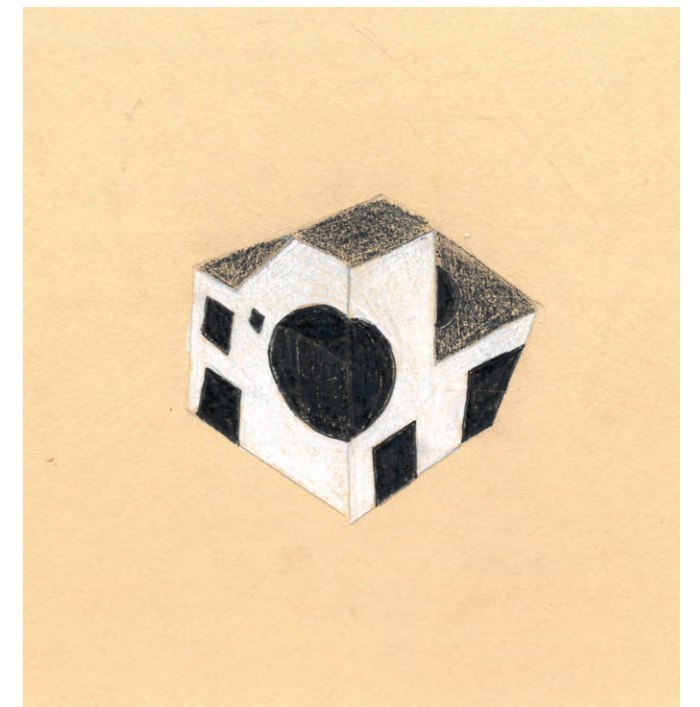
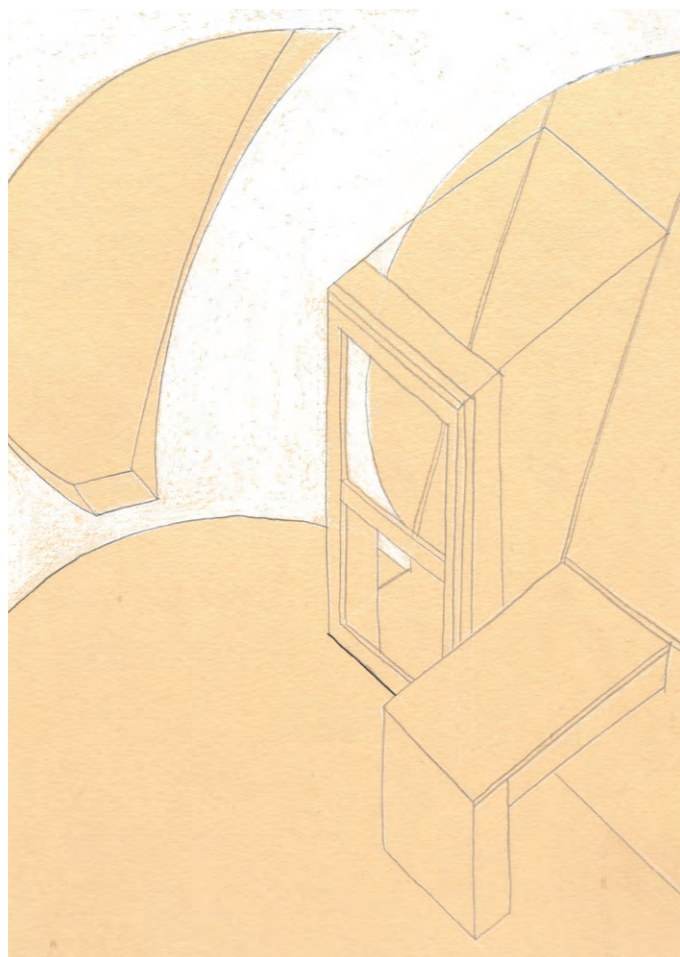

Coming Home

After strolling through endless maple forests, the smell of moss and fallen leaves still in his nose, he enters the house. Reflective Glass welcomes him, forming a tunnel through which he reaches a door, a wooden mahagoni door, a cold brass doorhandle in the palm of his hands. Tilted walls and curved ceilings, a straight door. He pushes the door. A ray of sunlight hits his face. He looks up through the skylight and sees the sun. The cold concrete floor below his feet steps down, lets the room appear even bigger. Looking at the sun he doesn't see the two steps in the concrete. Almost falling, his hand grabs the iron railing. He follows the railing, crosses the room, steps down another split level. His eyes are drawn towards a bright corner. Looking outside through that glass corner, he sees the maple trees that he has just been wandering through. Looking more closely, his eyes getting used to the brightness of the outside, he realizes that he can get glimpses of a chair in that corner, a chair from below, standing above him. The corner is reflecting sun rays into the room, reflecting his views to the outside. He walks past the table, all the dirty dishes from past night still on it, walks to the fridge, takes out the half empty bottle of white wine and pours a glass. With the wine in his hands he goes back up the three steps, crosses the

room, two steps. His empty hand grabs the railing again, leading to a platform above the central room. He follows the railing, climbs the stairs and again is drawn towards a bright corner in the room. But this time the corner is much rather a hole, the entire back part of the room seems to be carved out of the plywood, opening a full view on the forest. And in that opening sits a chair, the very chair he just saw from below, he realizes.

1 How a formal and volumetrical concept, once overlaid with the restrictions of everyday use, creates new qualities.

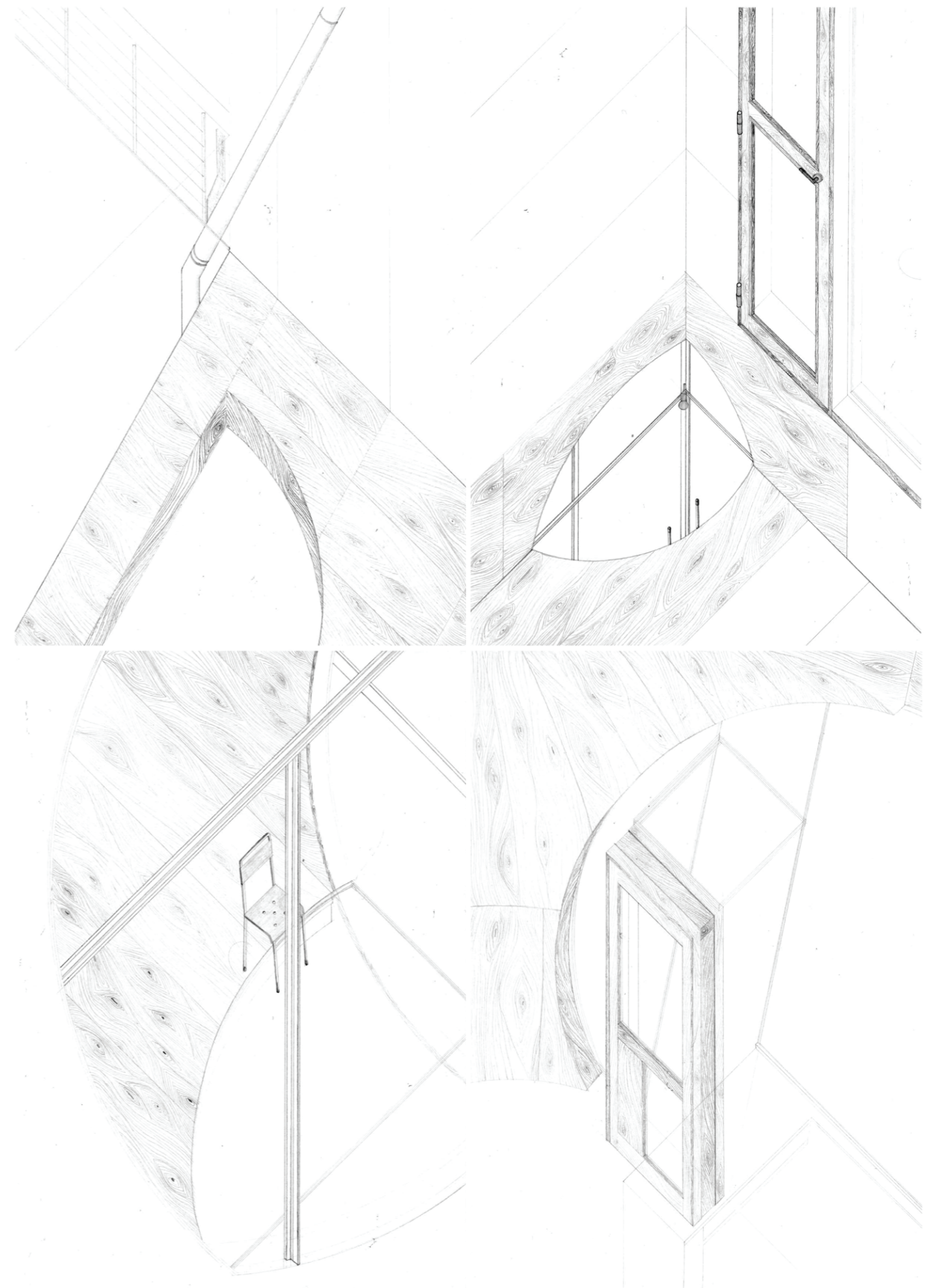

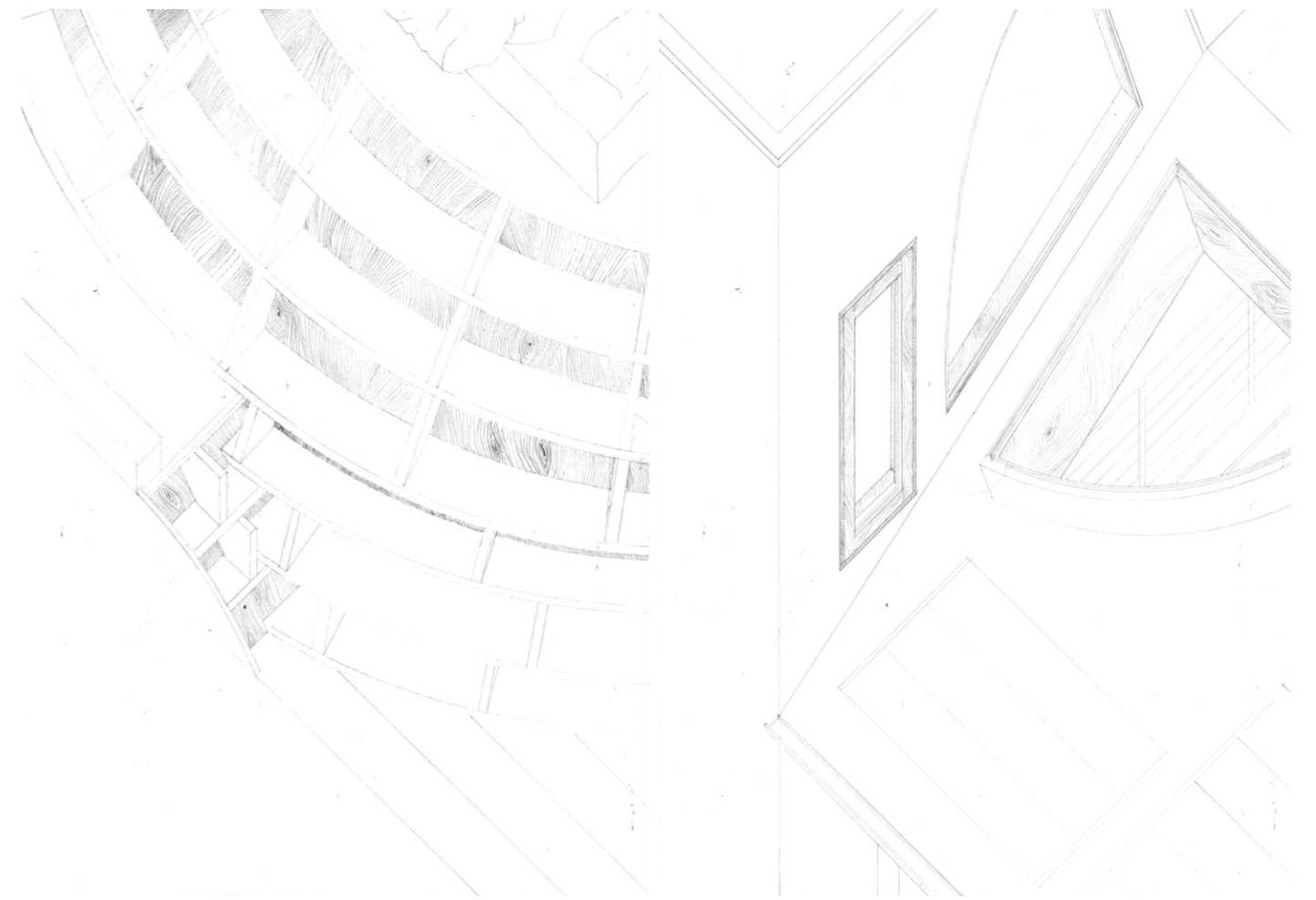
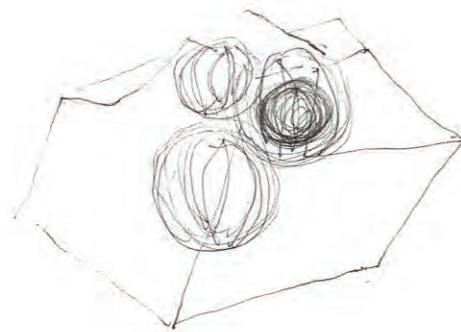
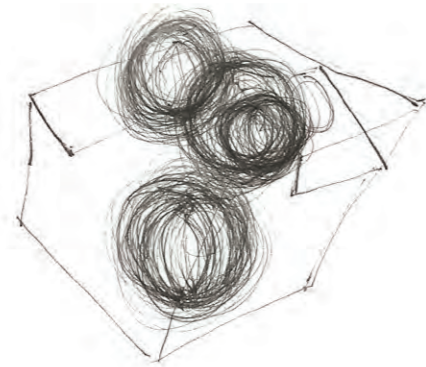

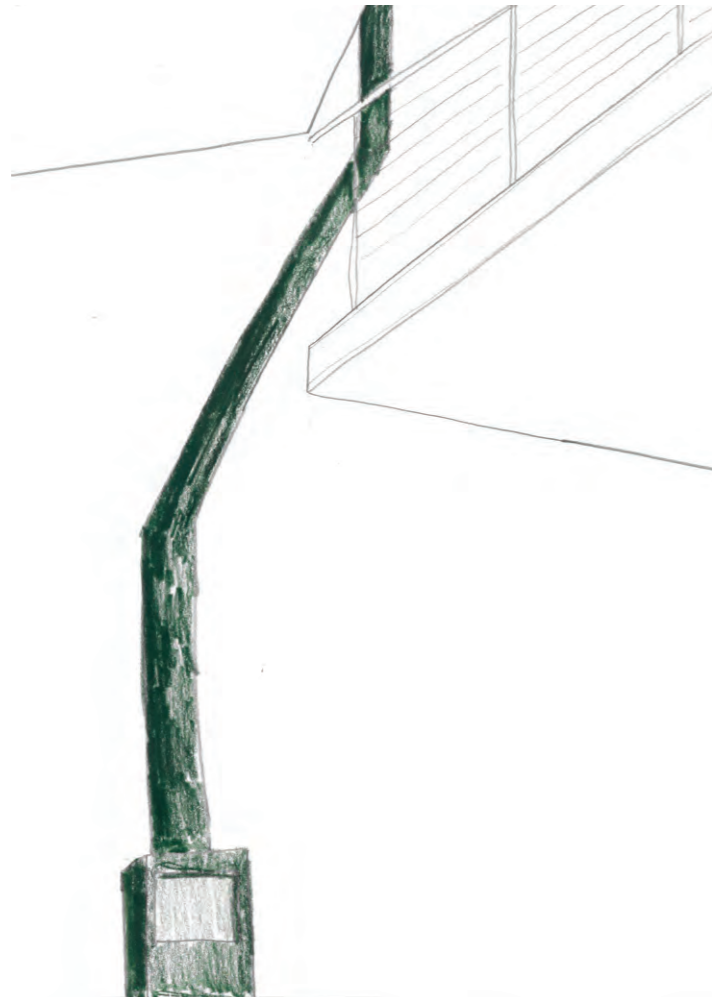

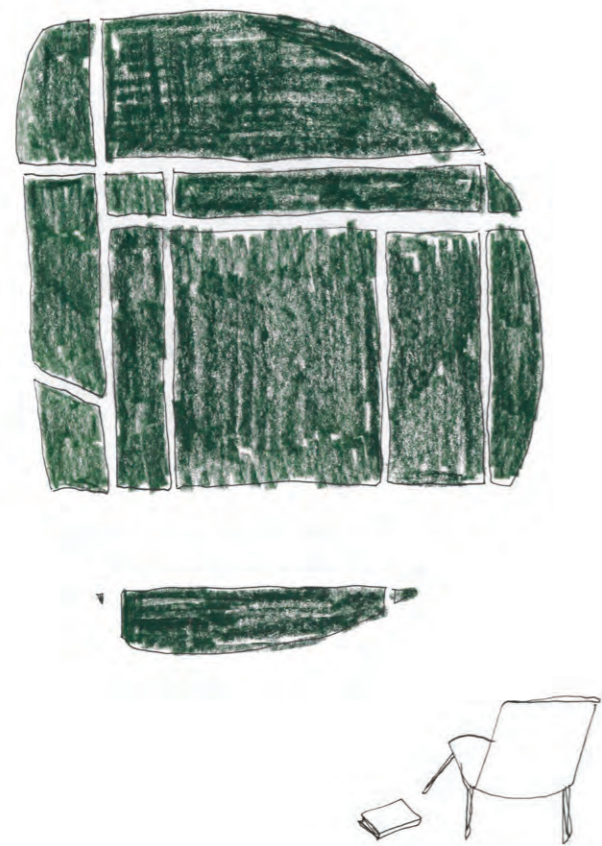

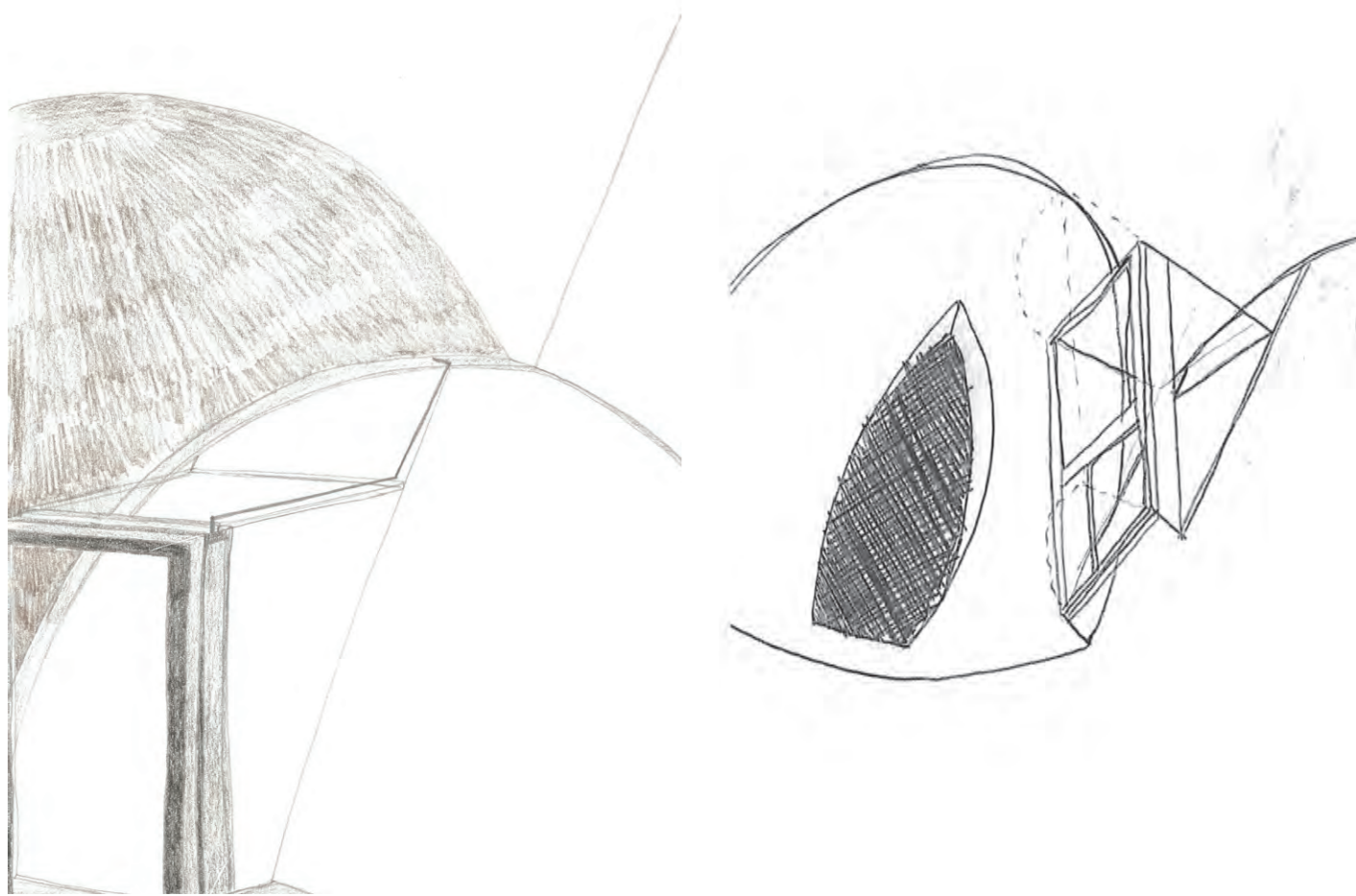

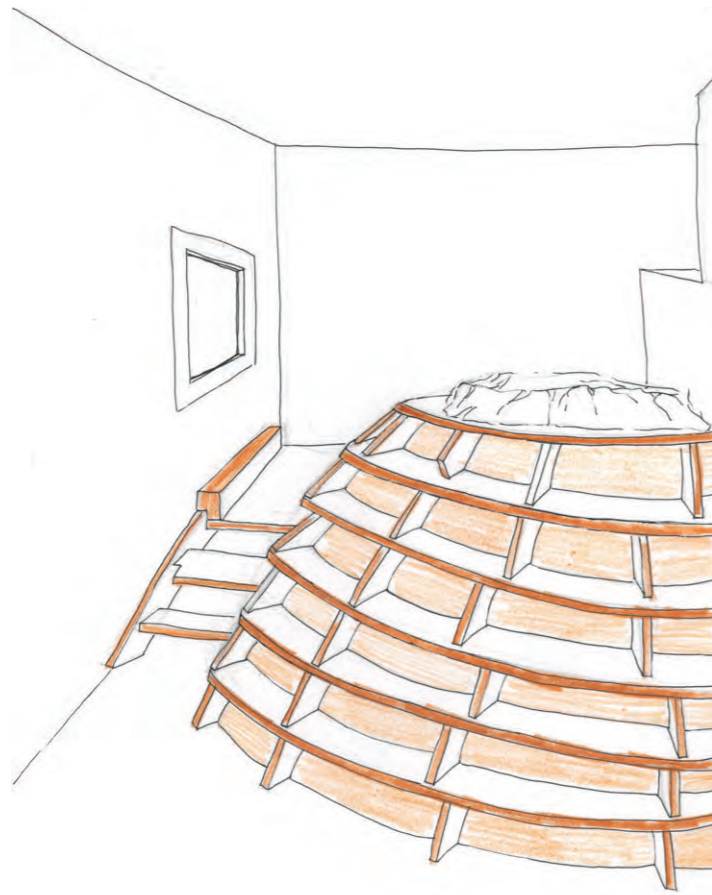

Movement 2

America



De Wachter House in the Context of House Ex of In (US)



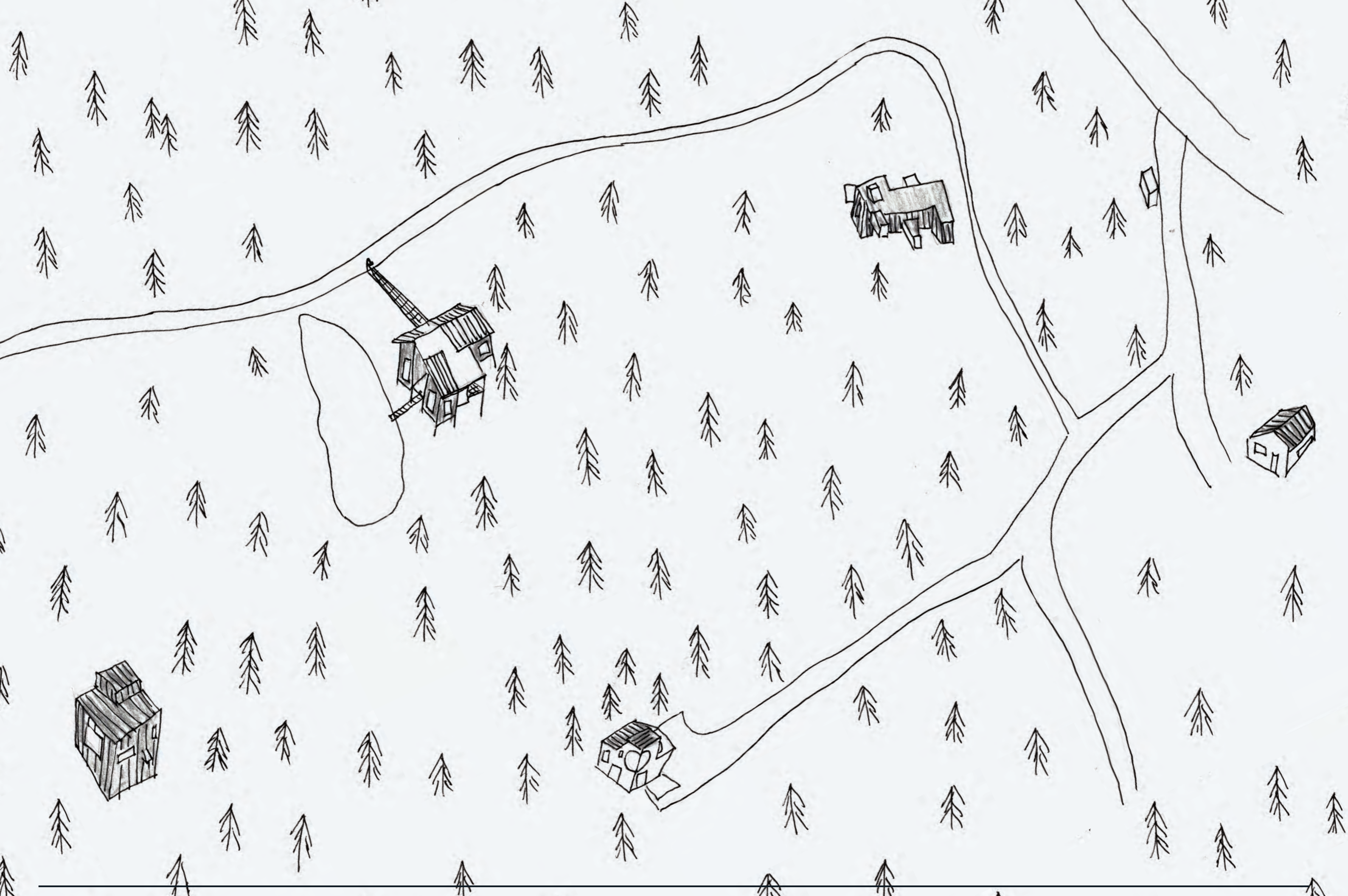

House for the contemporary witch

Moonlight

Bathtub

It is almost midnight, i'm lying down in the bathtub. The flame of the candle is reflecting on the wall, like a dance. I just part the curtains and grab a book. With the other hand, i grab the glass of wine from the small hole on the wall. I like how you can always do many things at the same time in this house. Maybe at some point i will get tired, but for now it seems just like the only way to live.

My other favourite thing here is to be able to cook from the terrasse. Or to take your tea with the plants in the greenhouse. Maybe the fireplace is the only room where i just need to do nothing and look at the fire.

Observatory

Wait, which day are we ?
How could i have forgotten that ?
One step down, and then ten steps up.
Not mentioning the water following me. Hopefully, i prepared everything yesterday. I open the skylight, point the telescope towards it, and gaze at the sky. The white disk is slowly disappearing in the dark sky. Everything gets darker, as just one light stays, one square window far away in the woods.



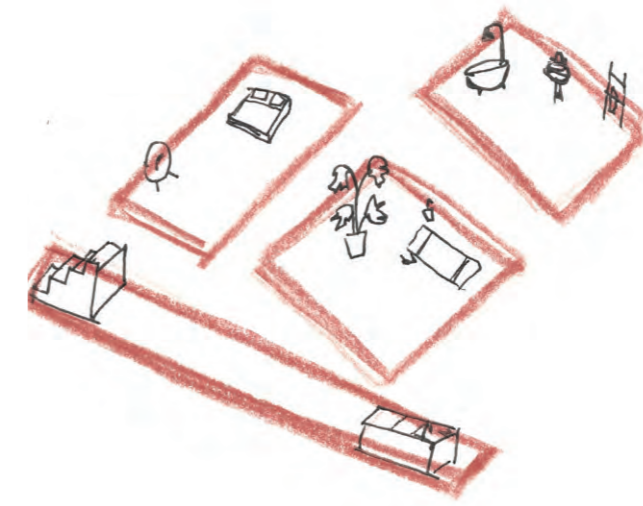

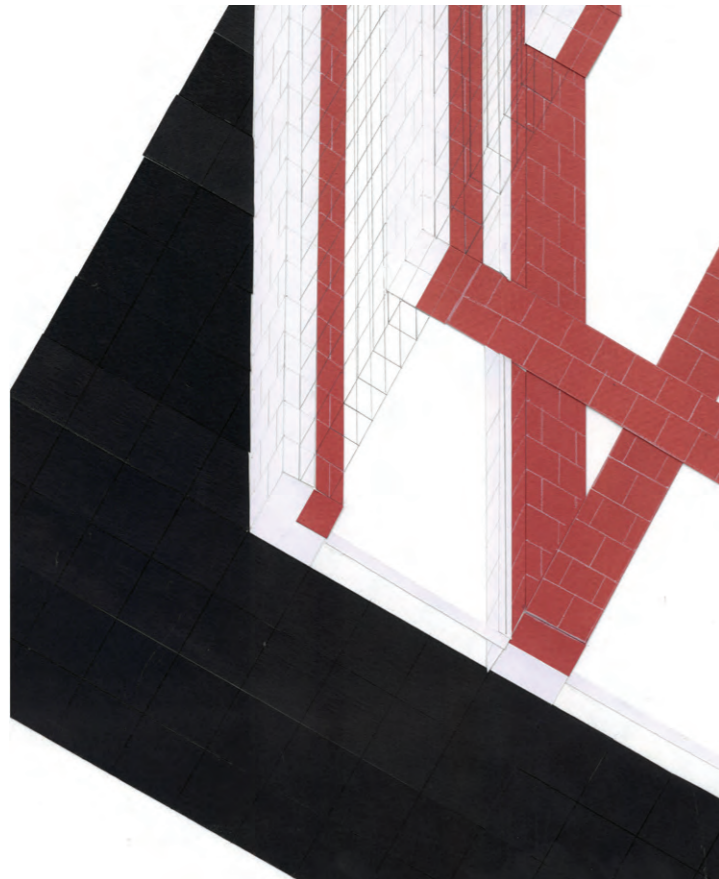
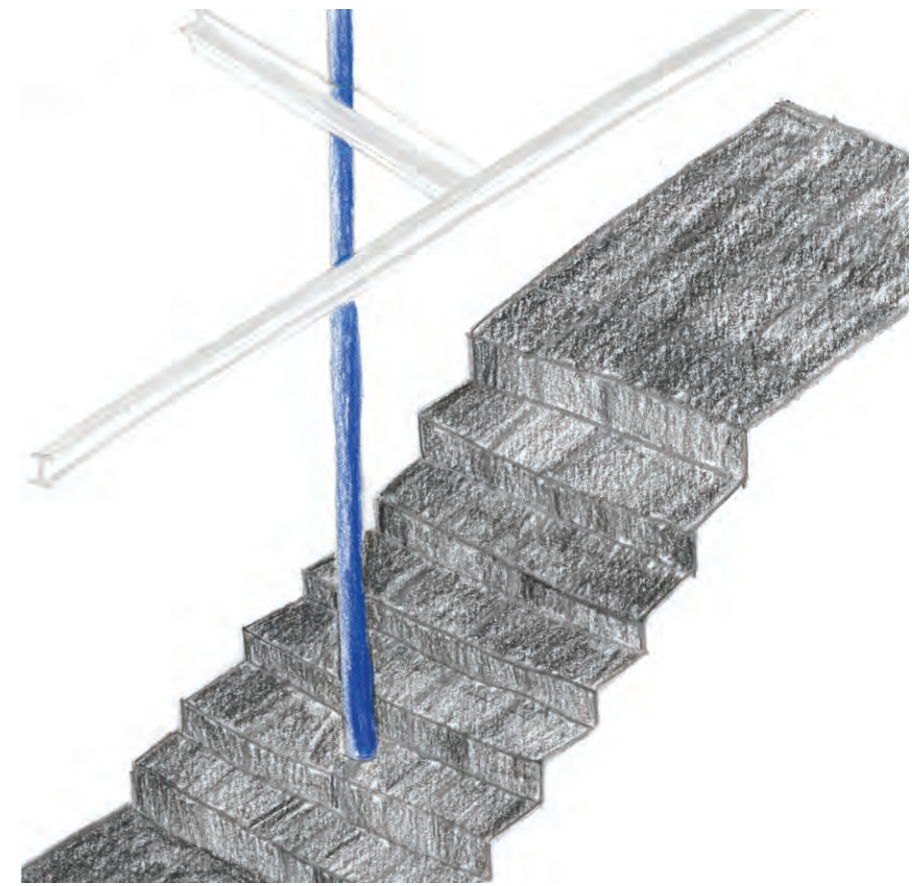
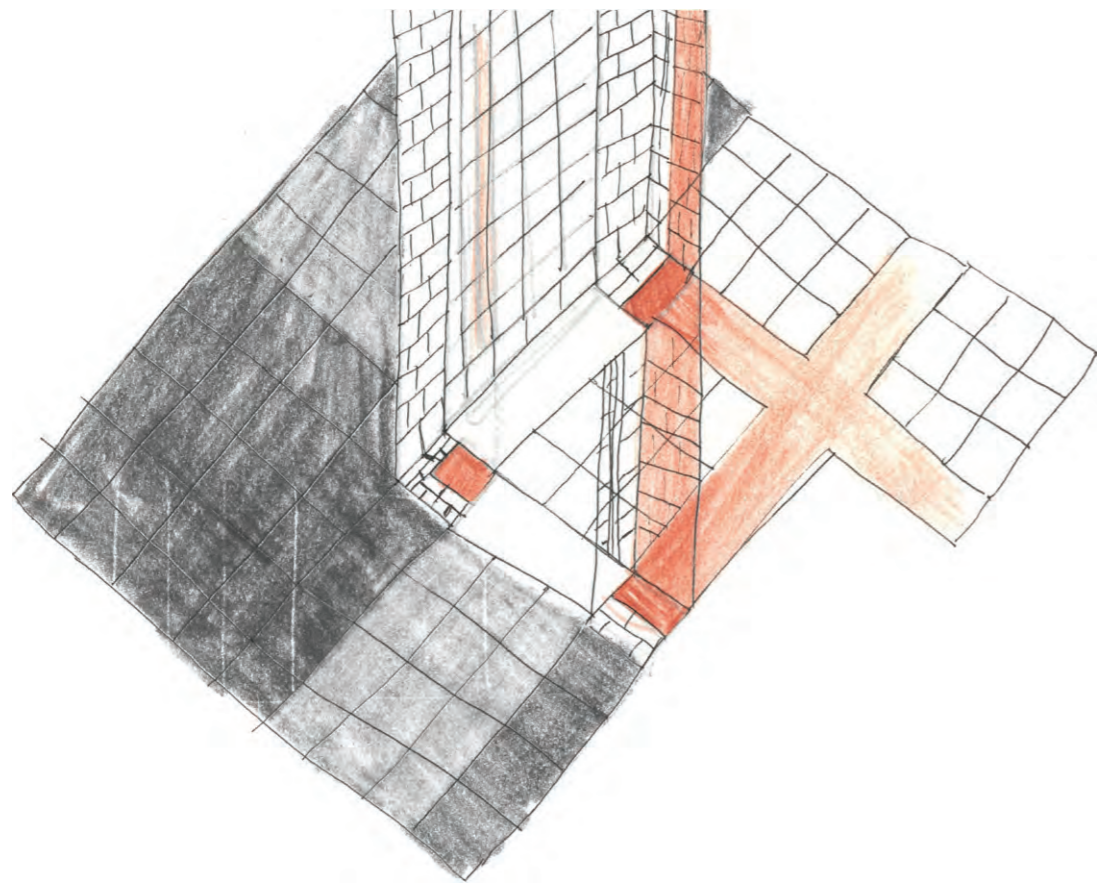

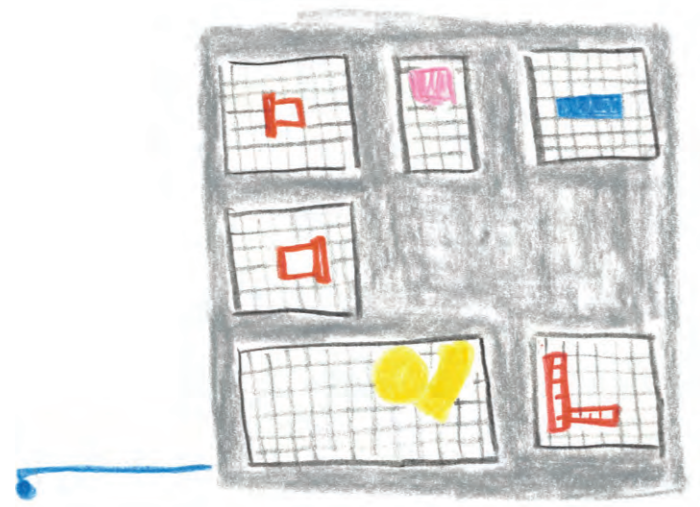
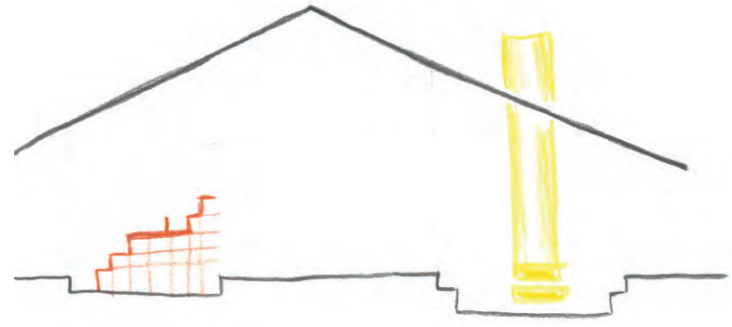

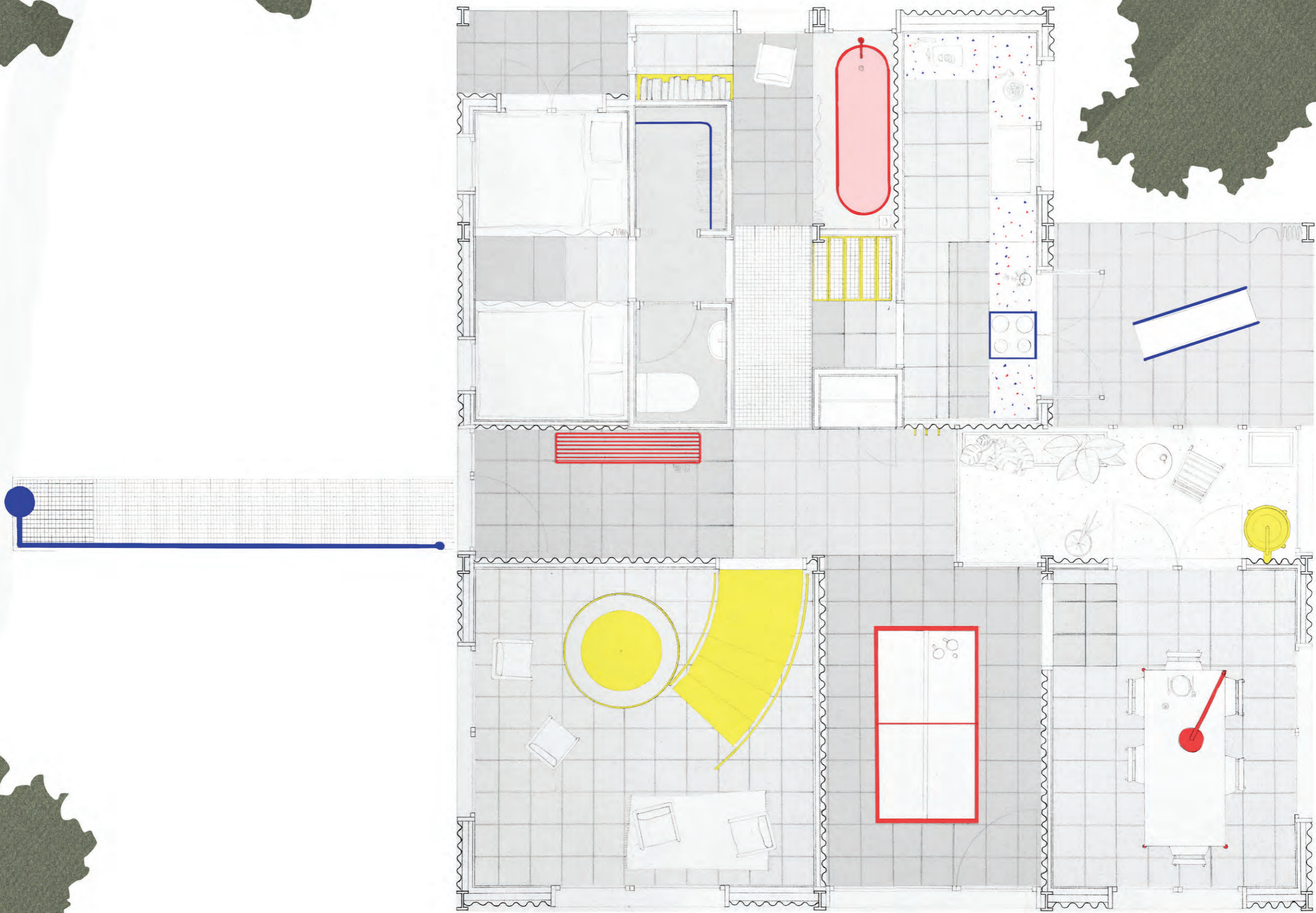





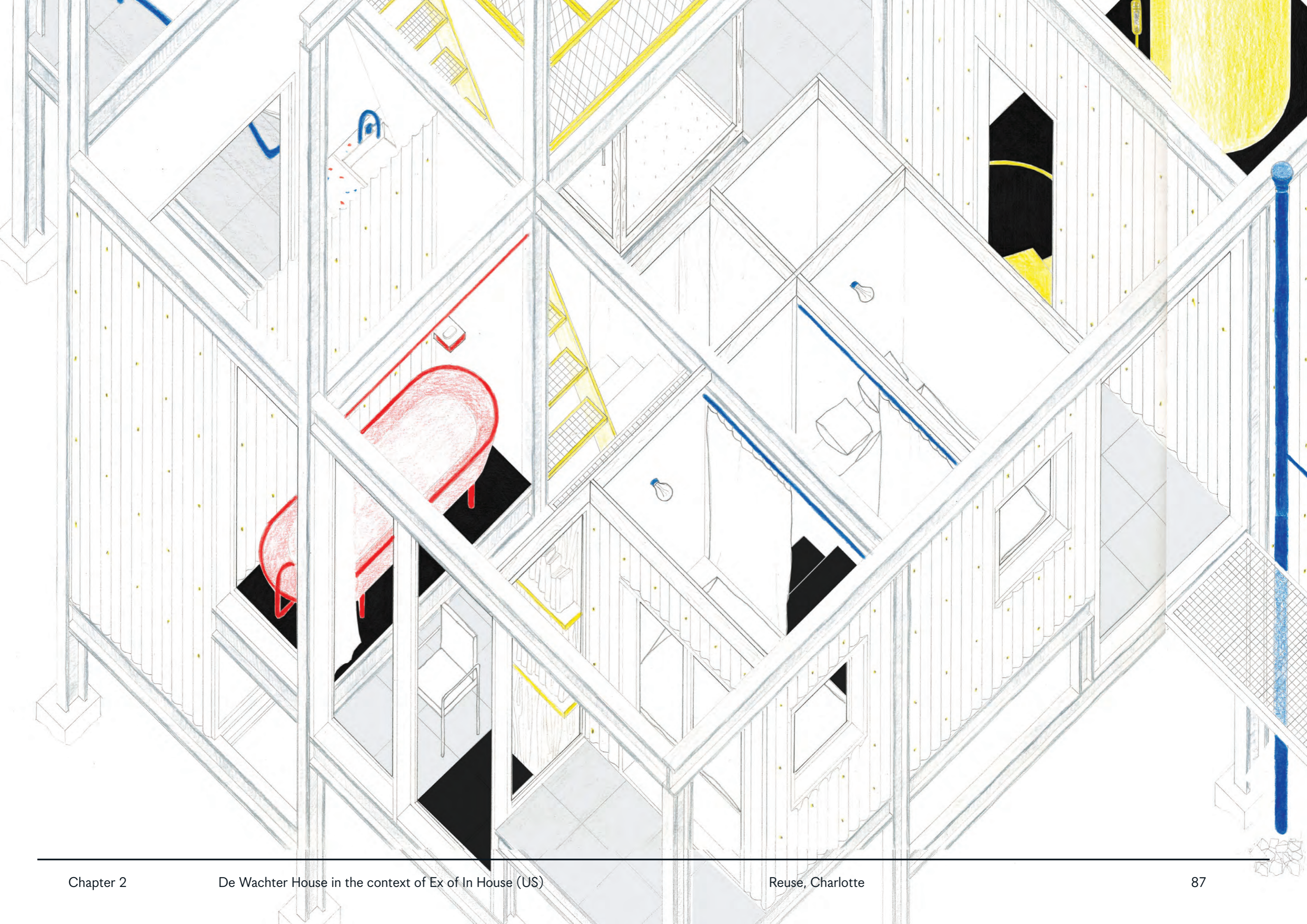

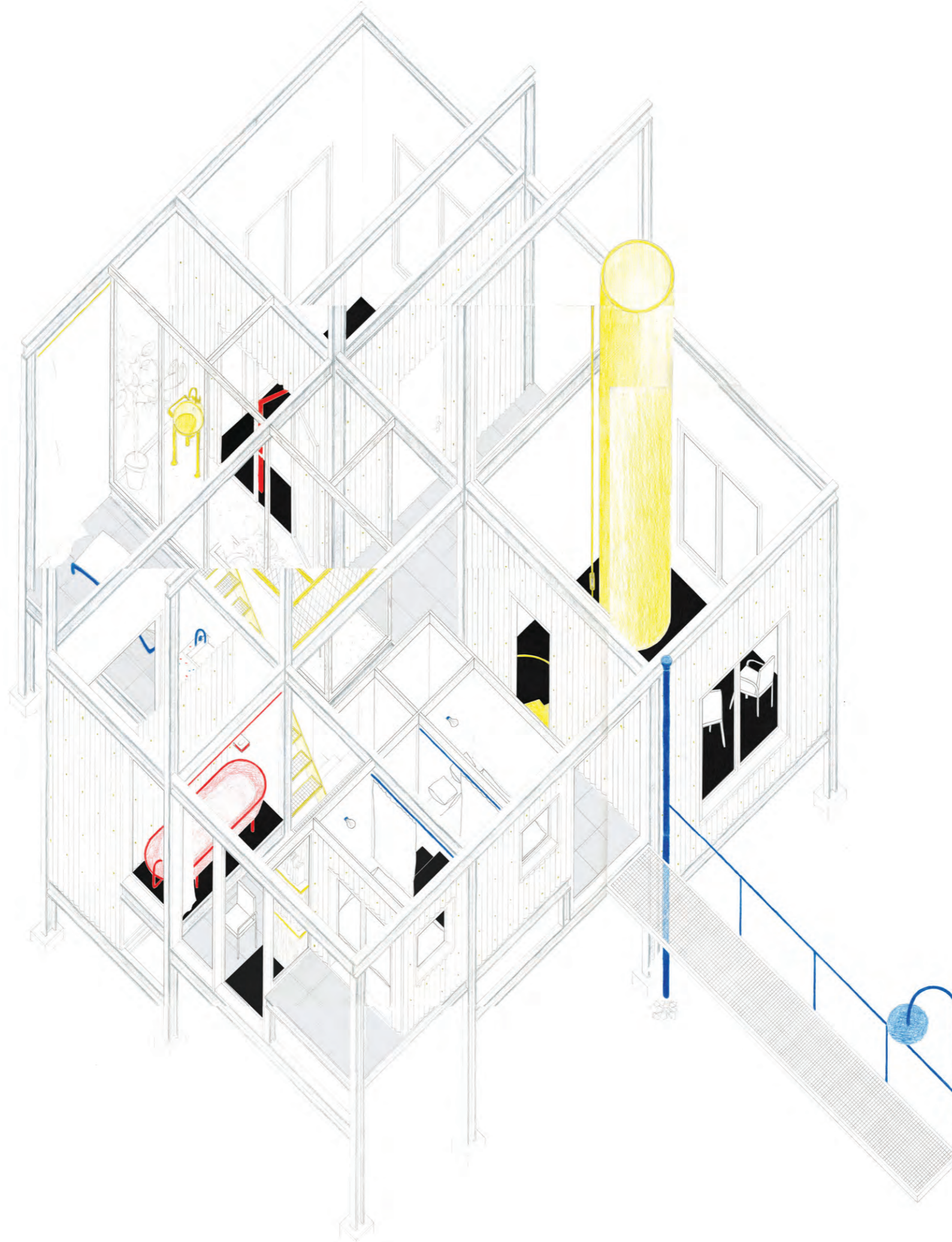



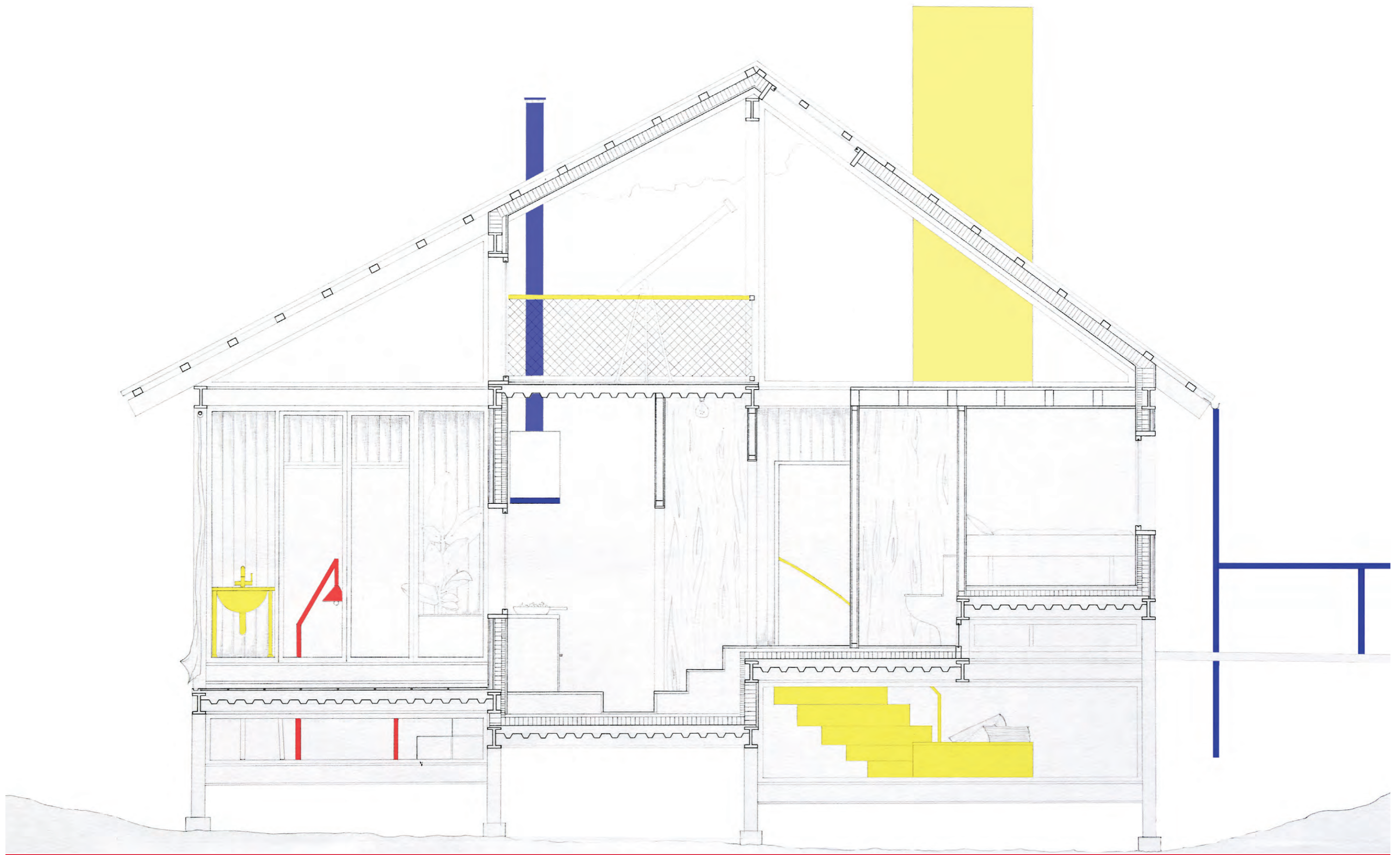



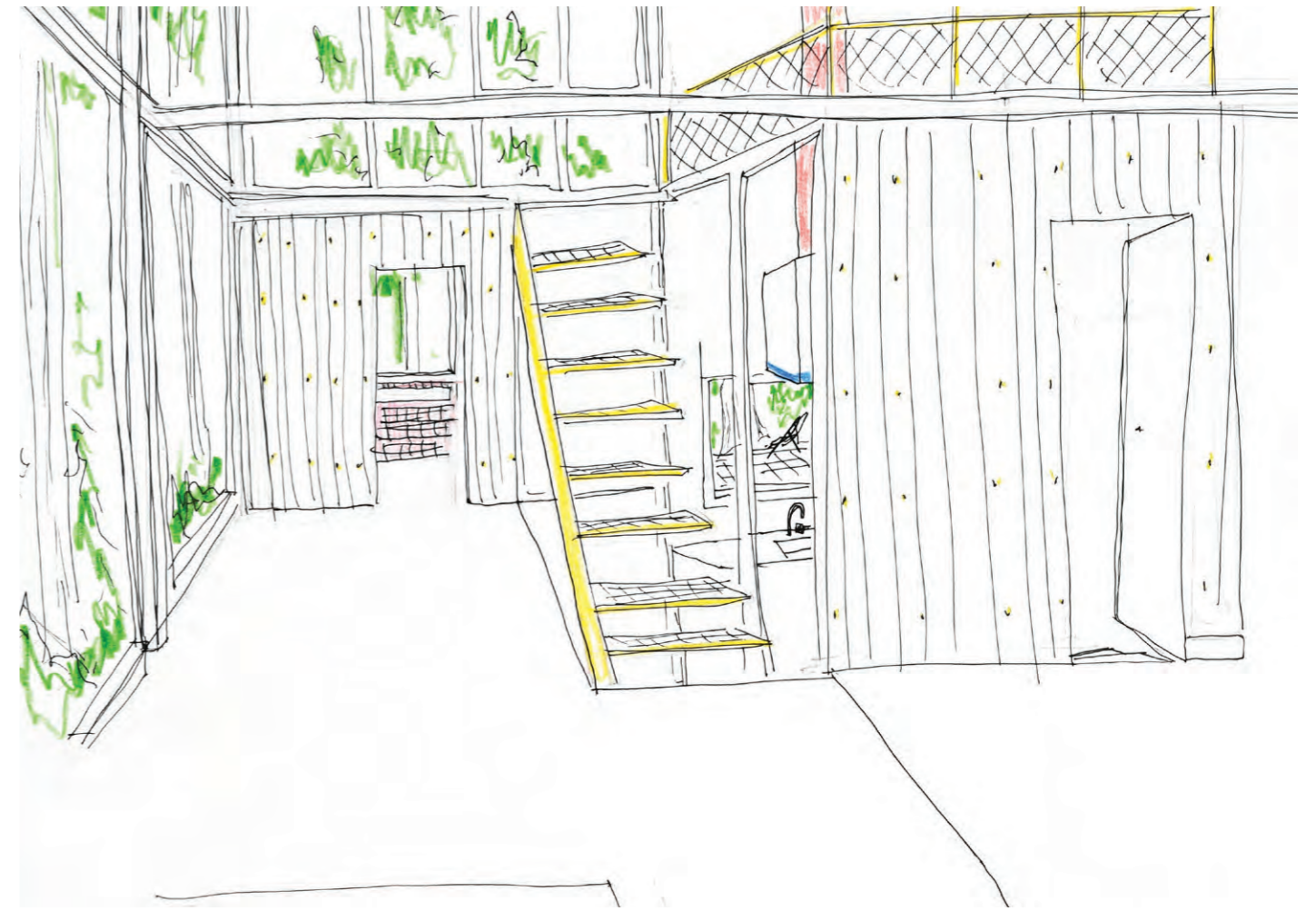
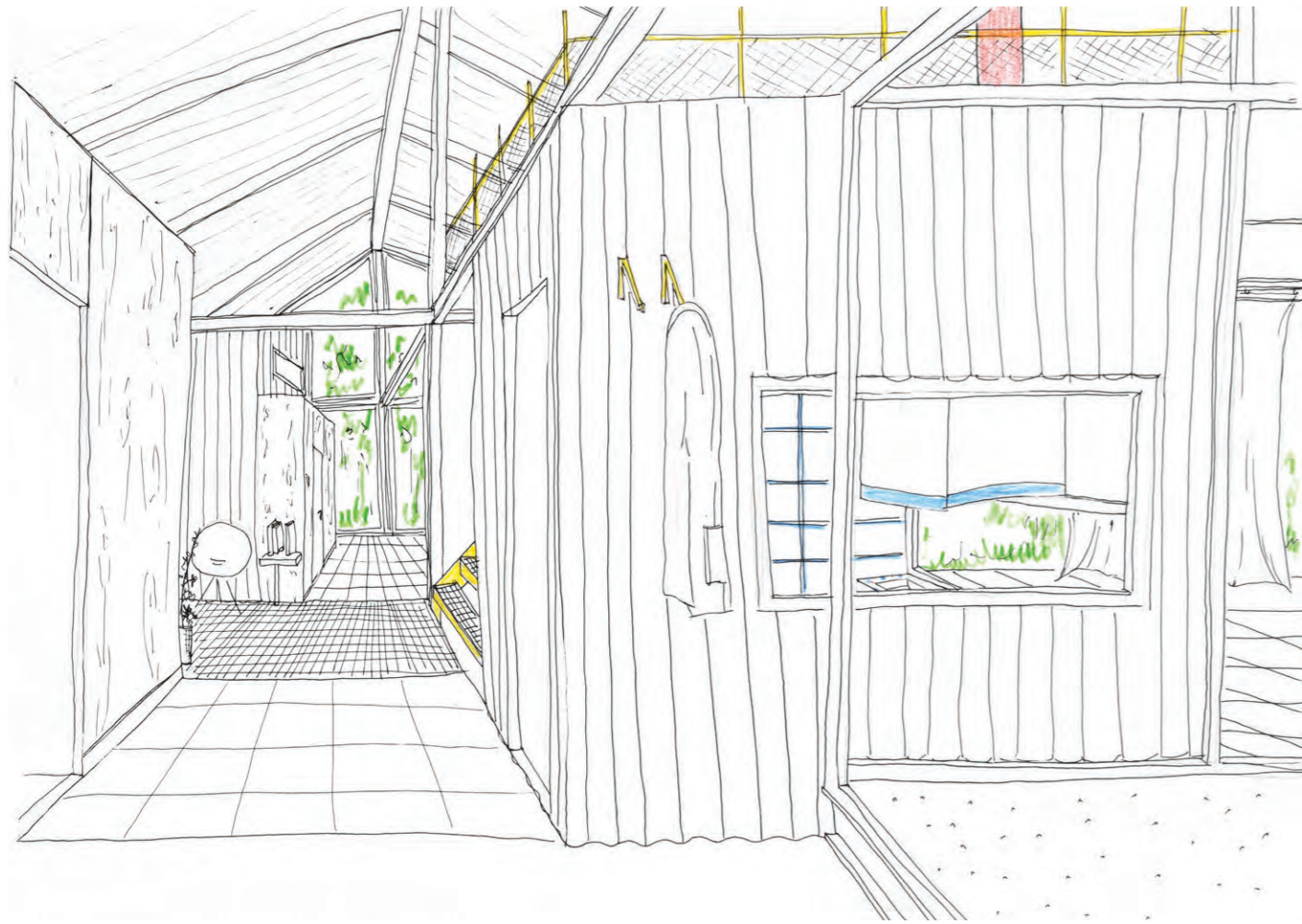





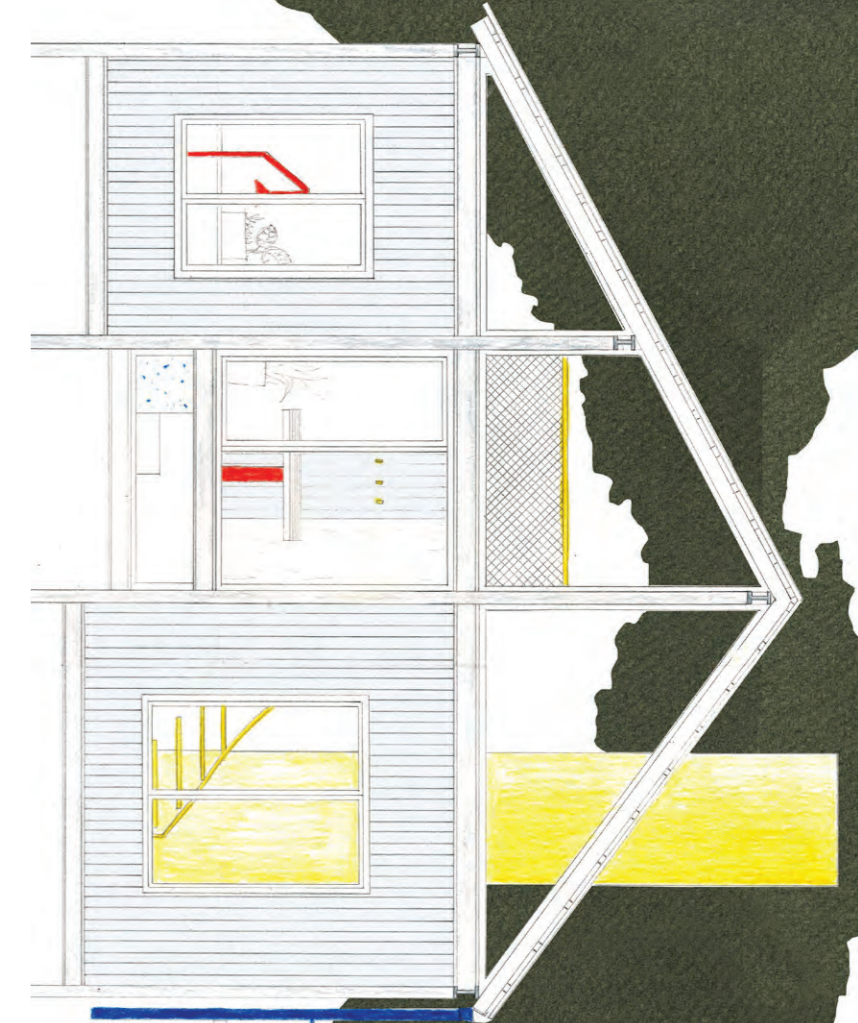
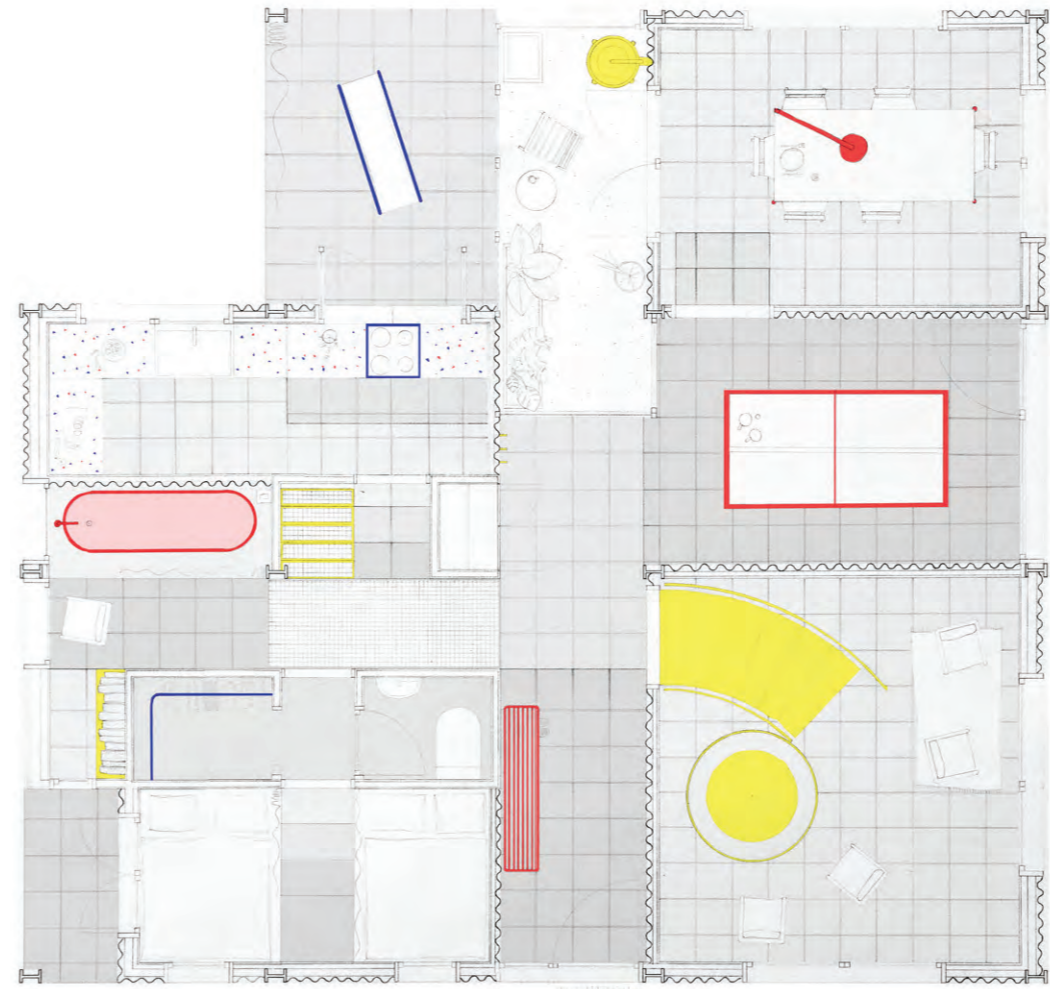
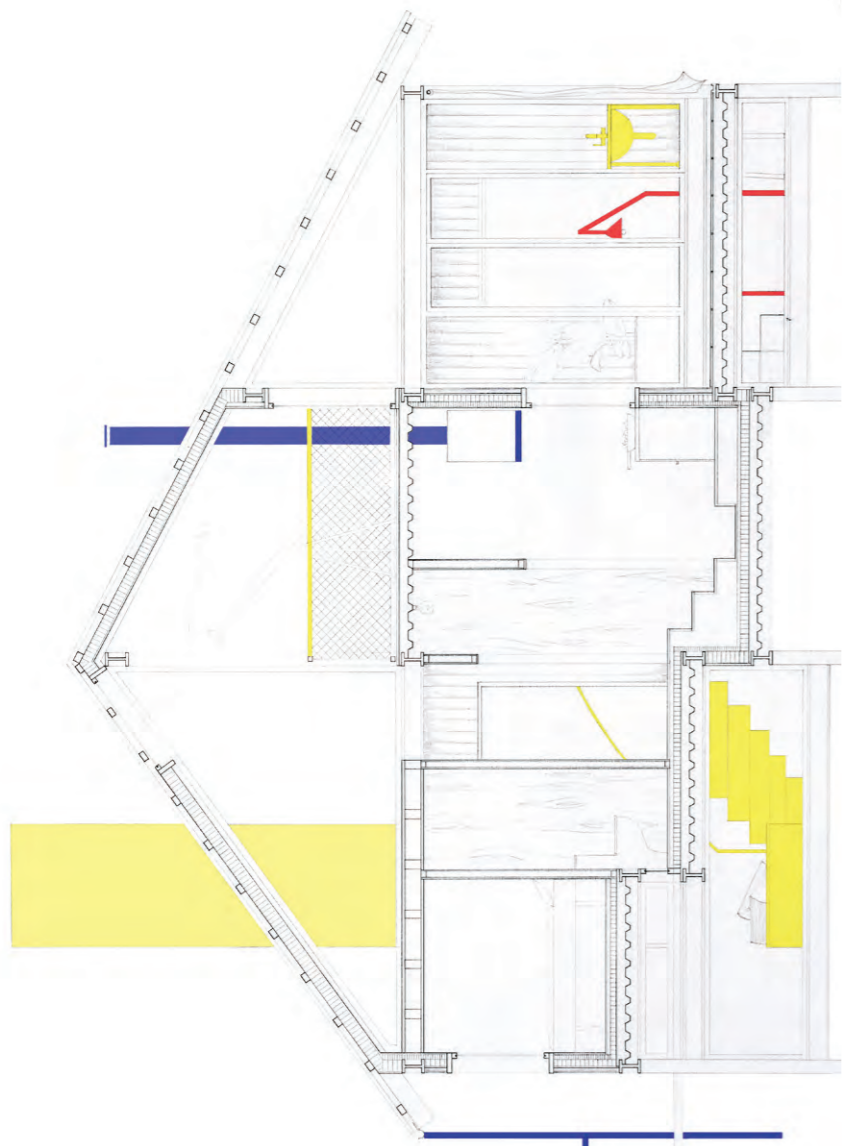



House for an Art Collector in the Context of House Ex of In (US)

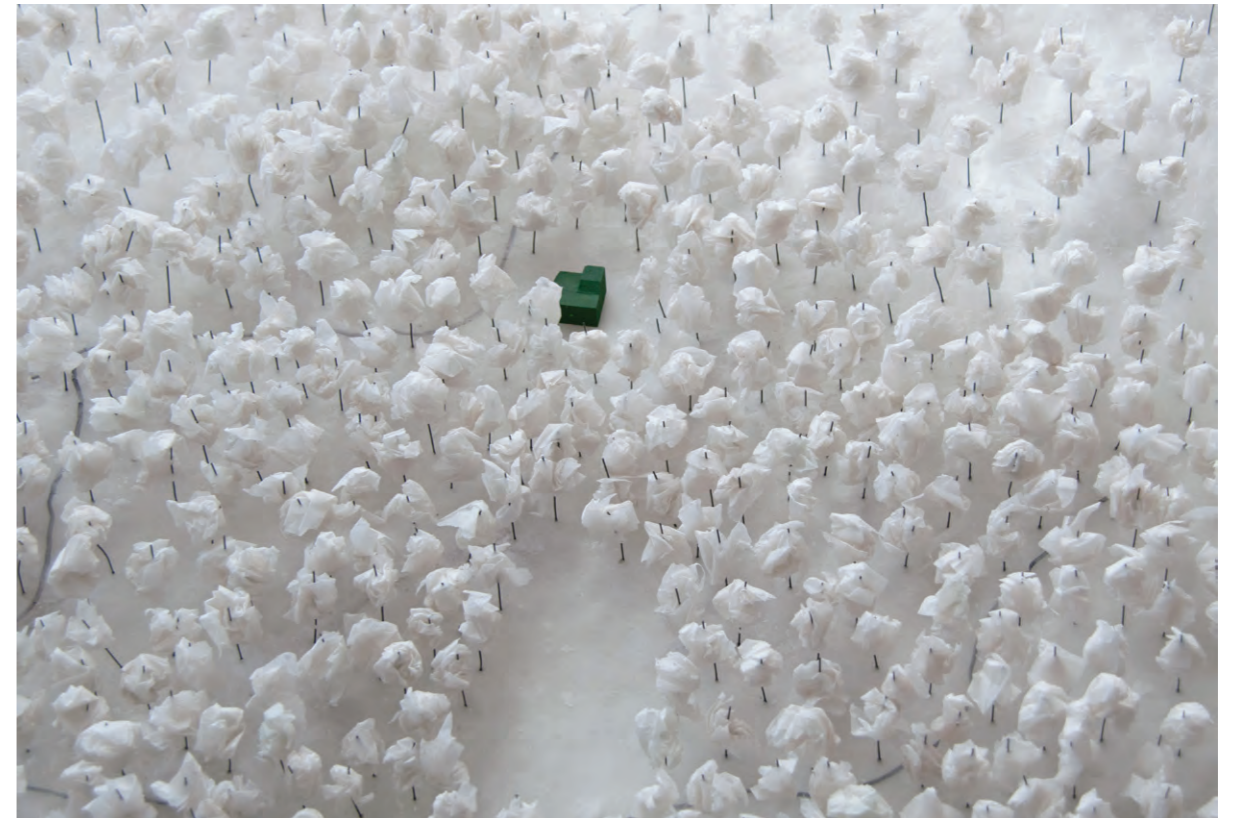

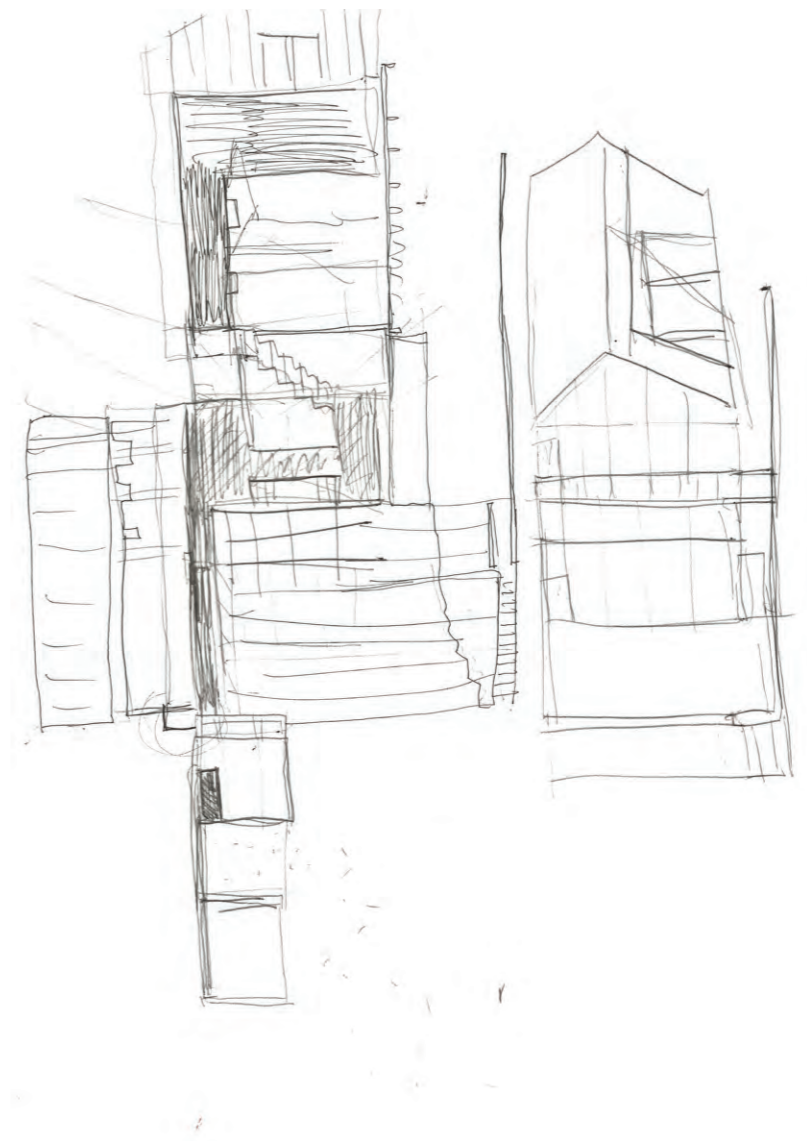
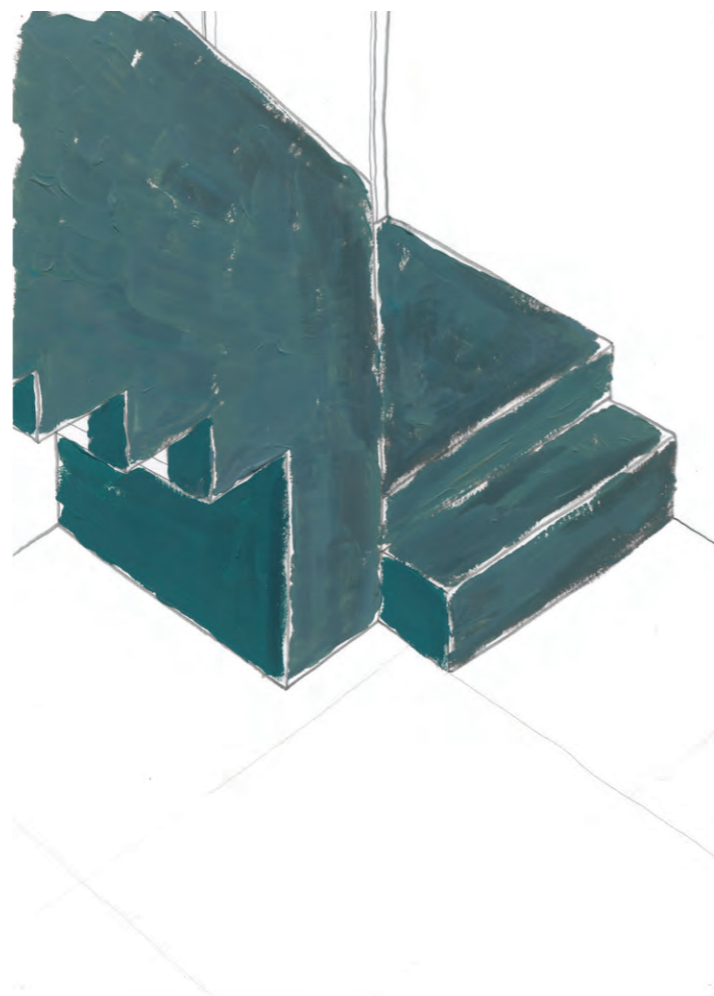

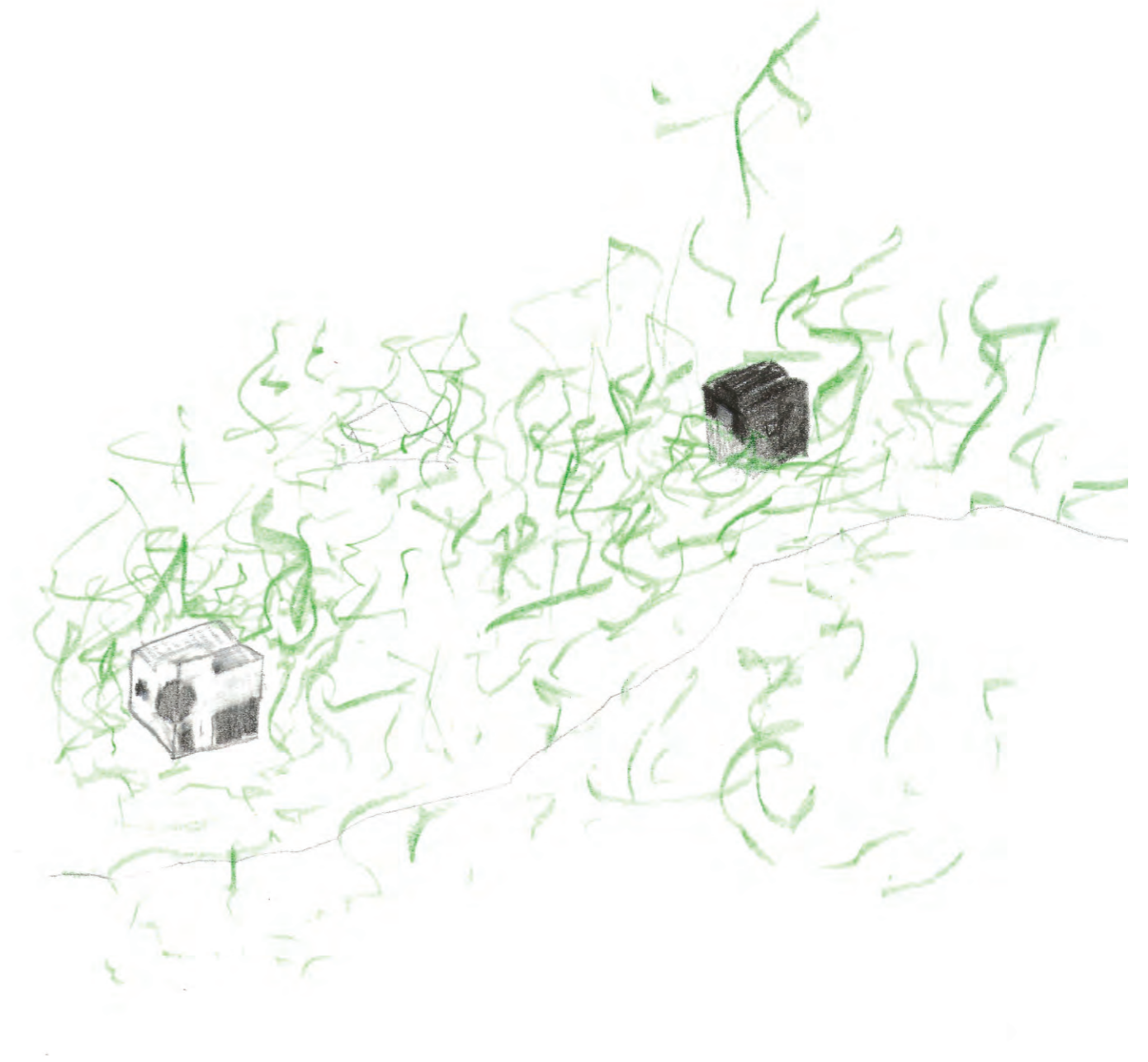
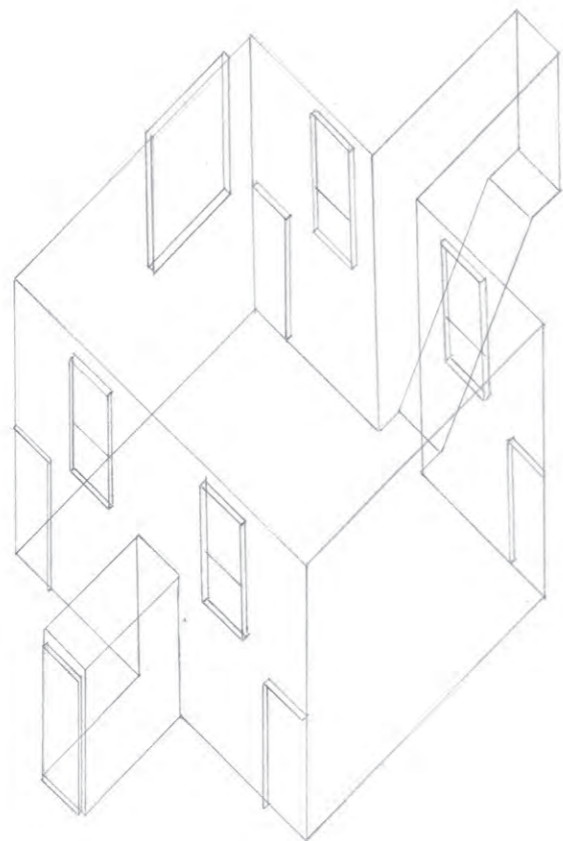

they stand there, face each other, their heads stuck together, as if they were talking, in their secret group, their secret language. from the outside you would never comprehend, only from within you understand.

1 The alcove-like spaces surrounding a central room, relating to it through change in materiality

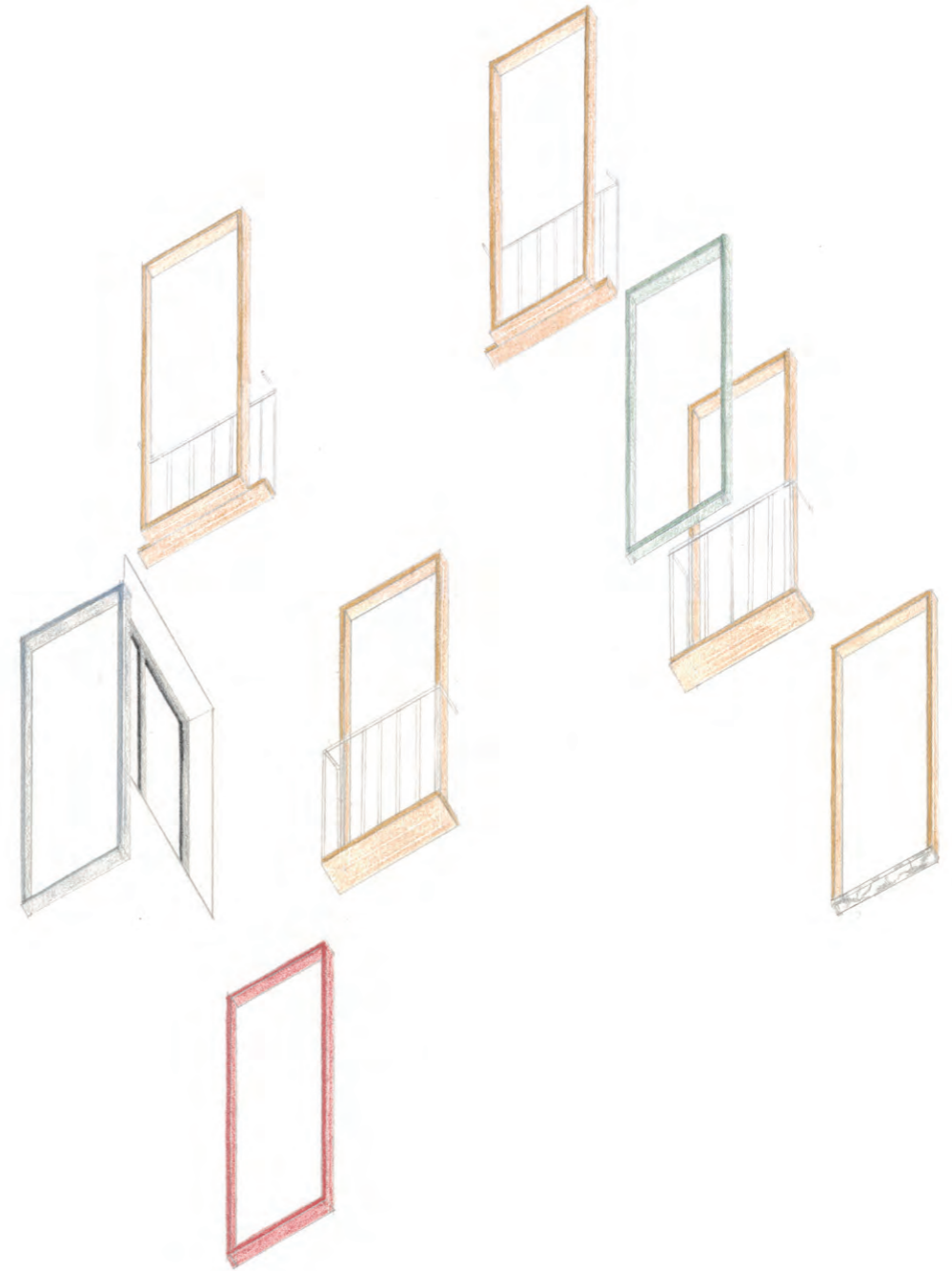

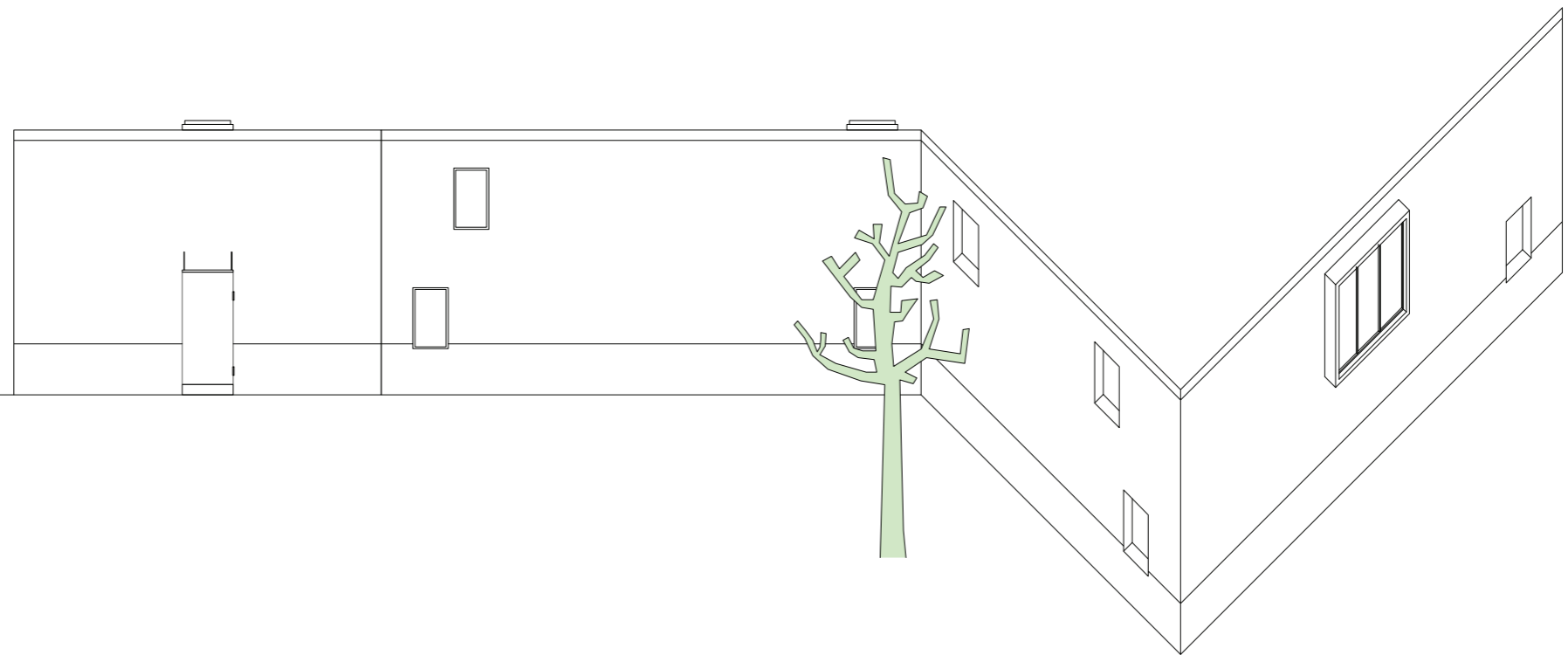
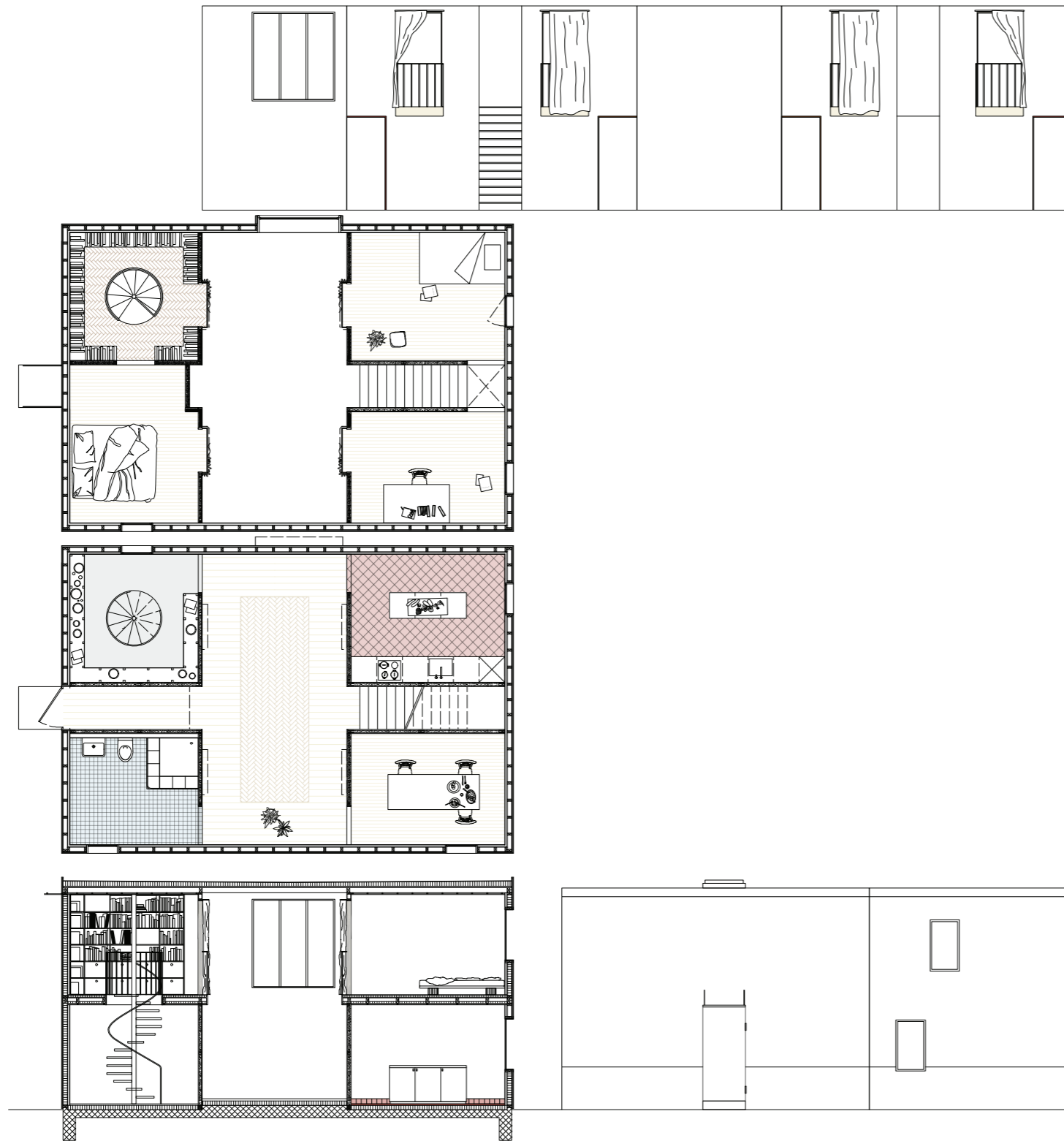

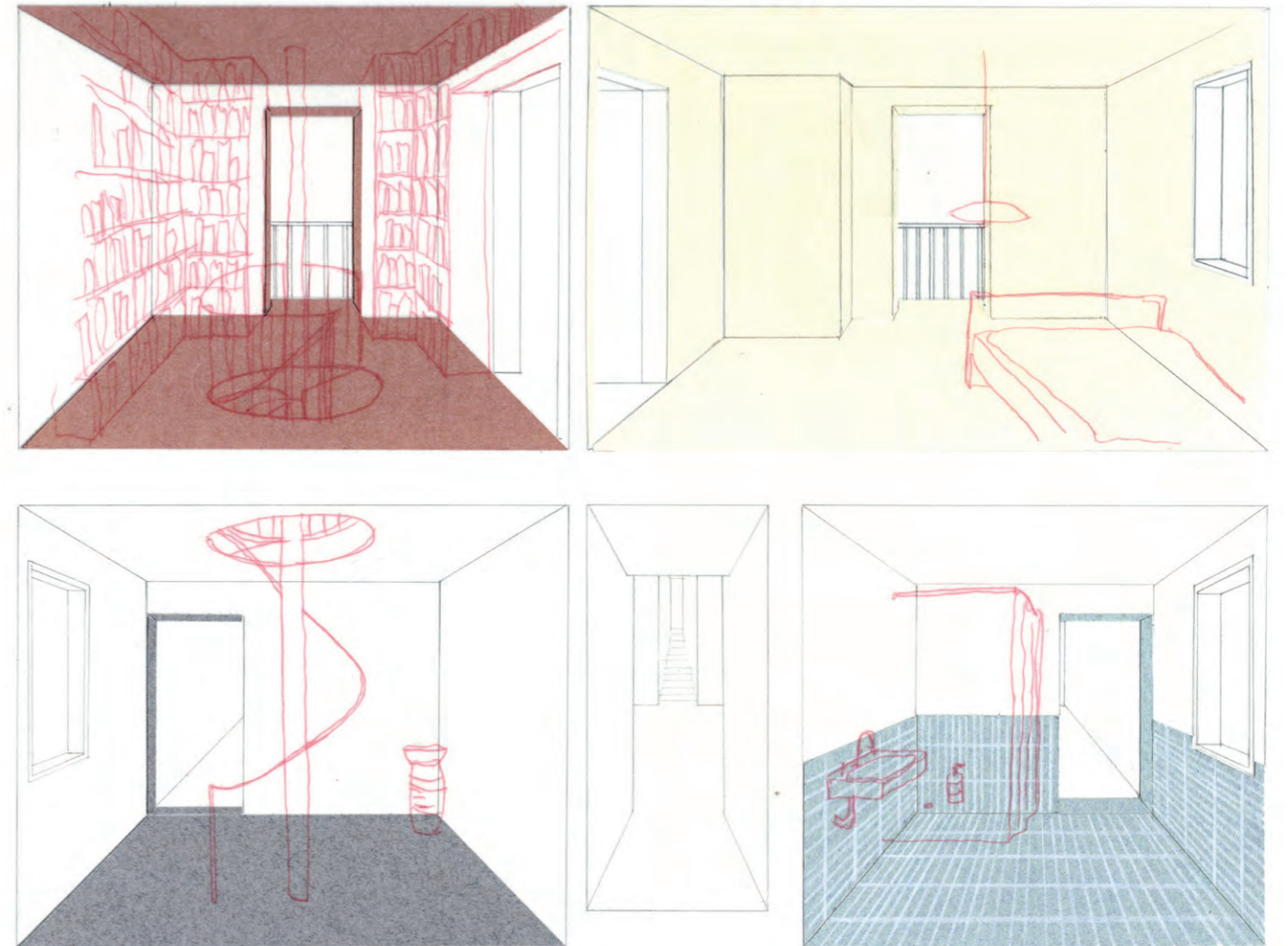
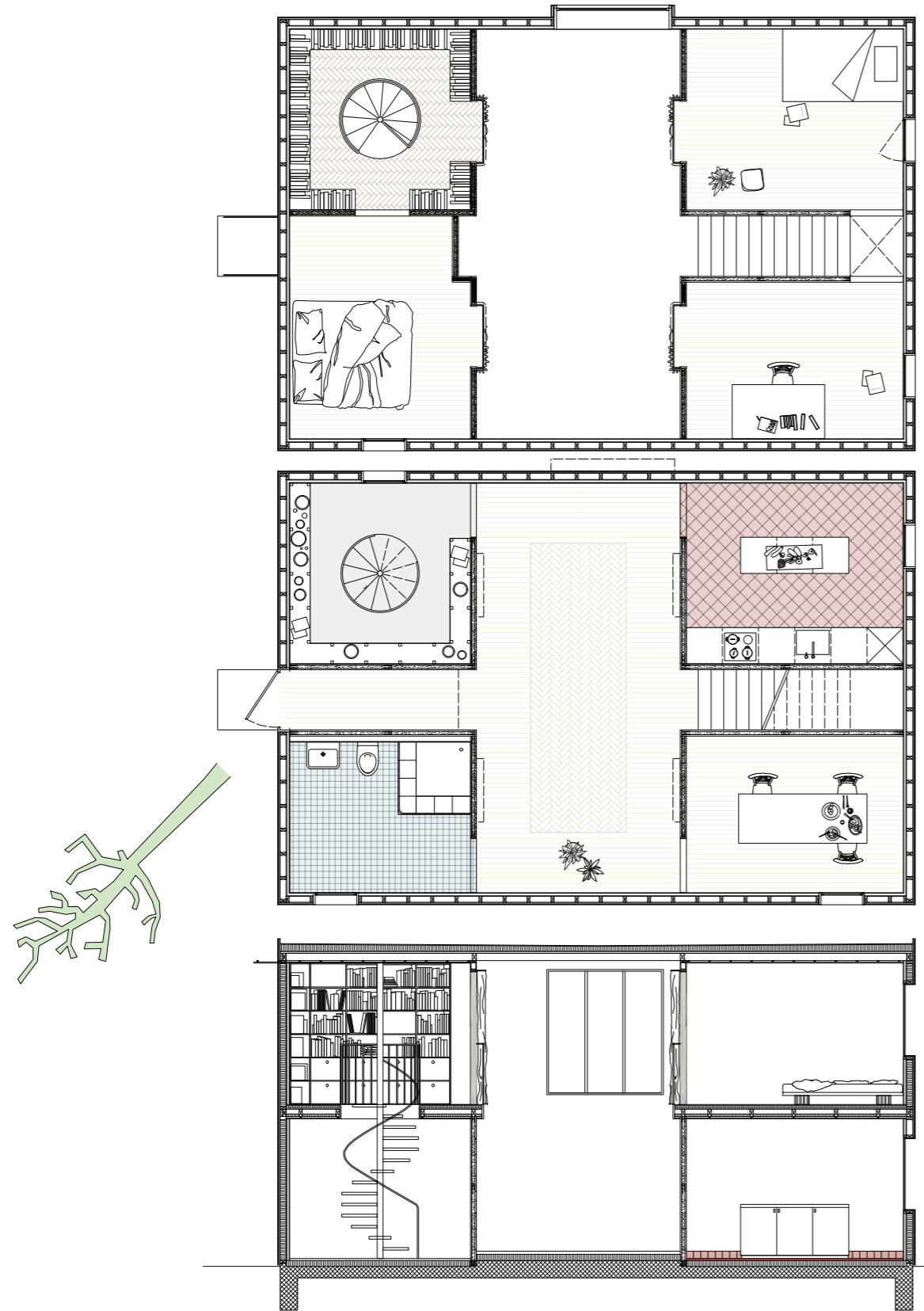

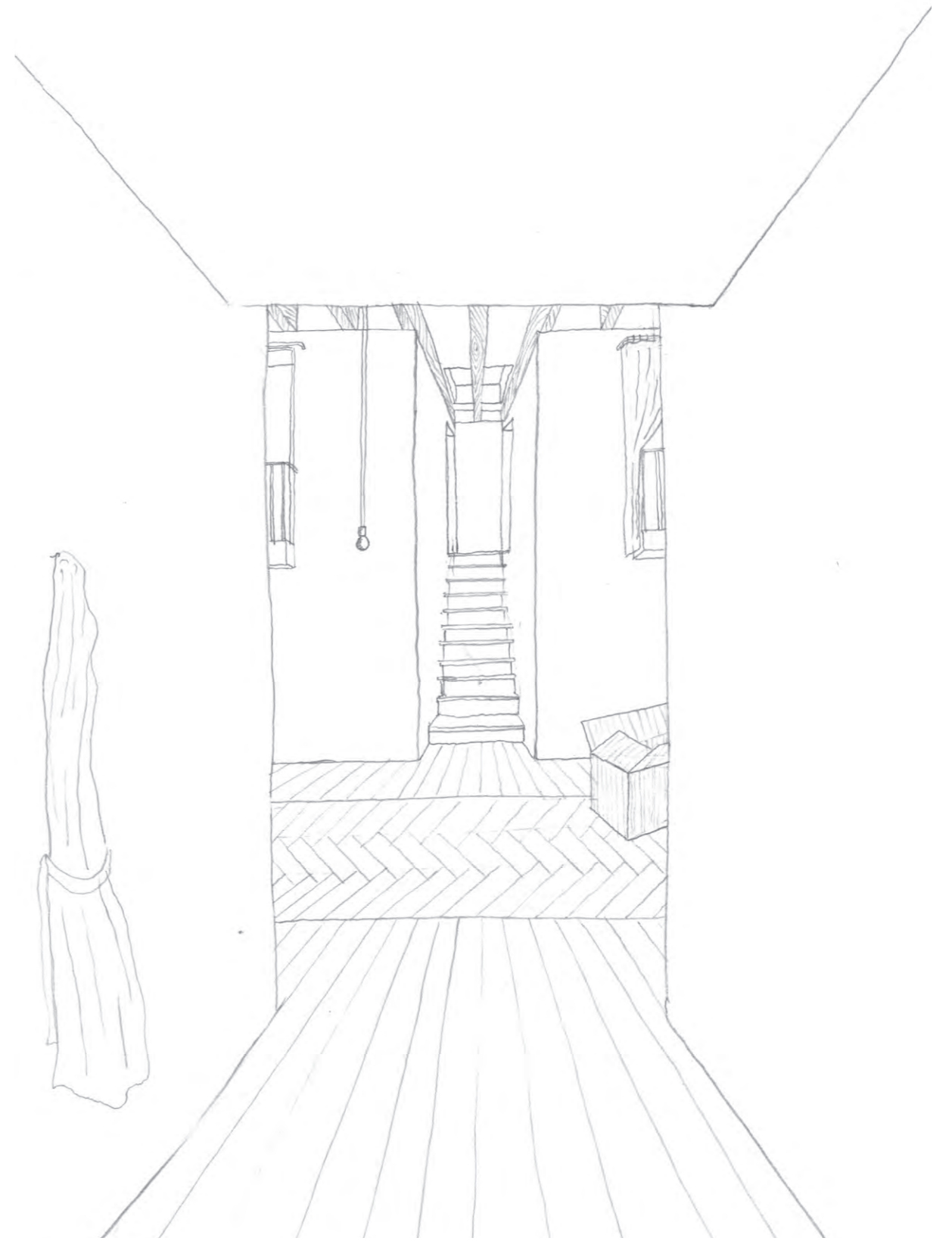
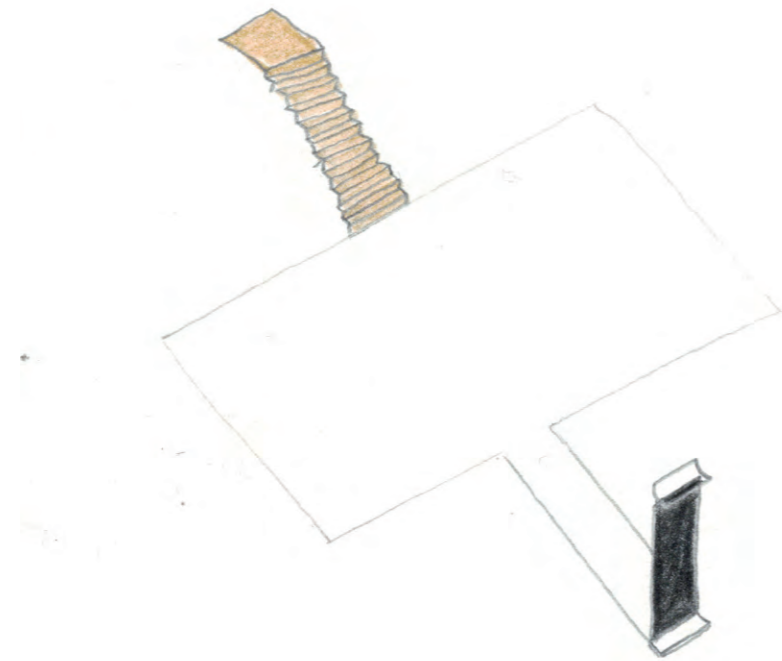

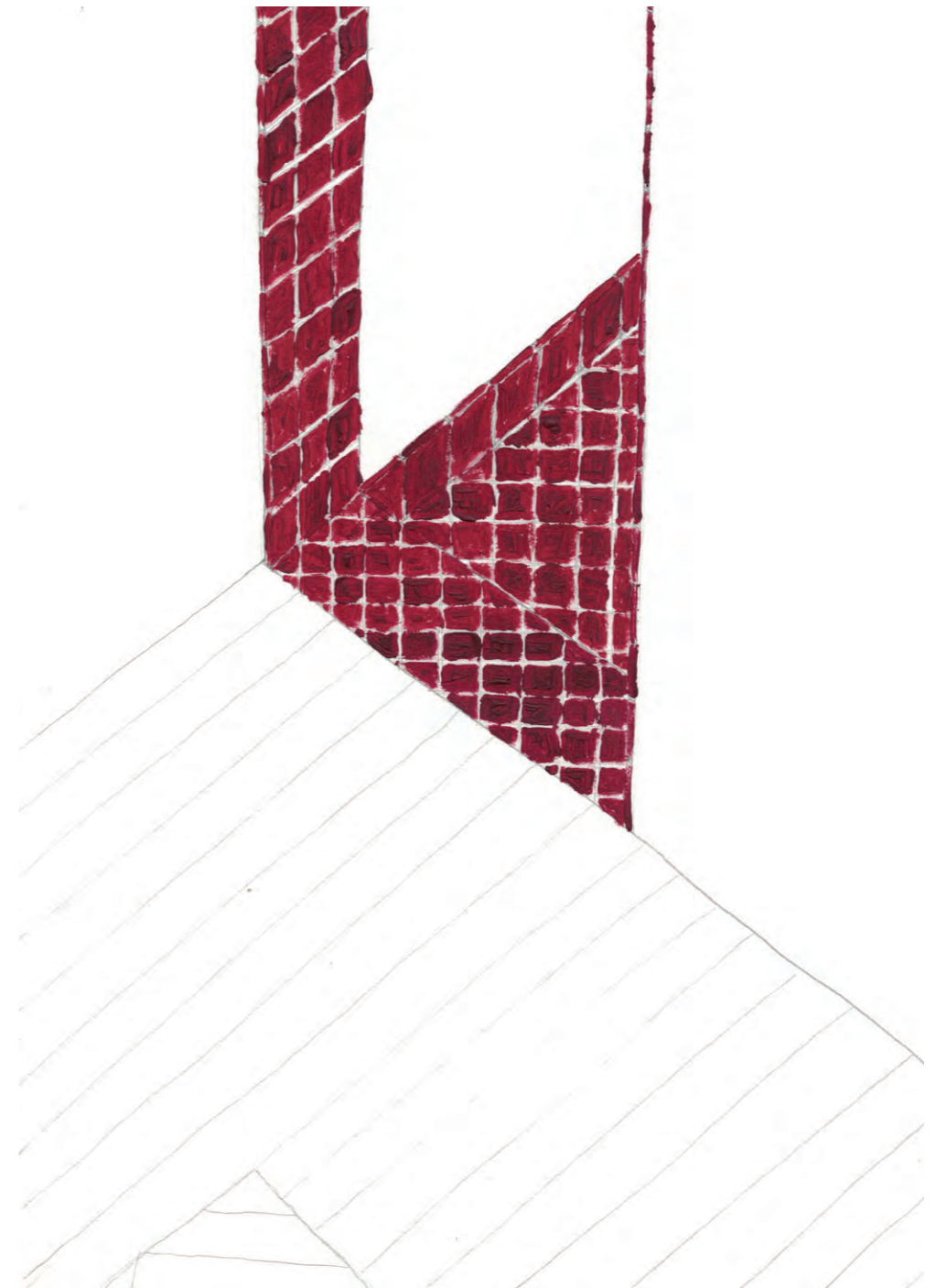
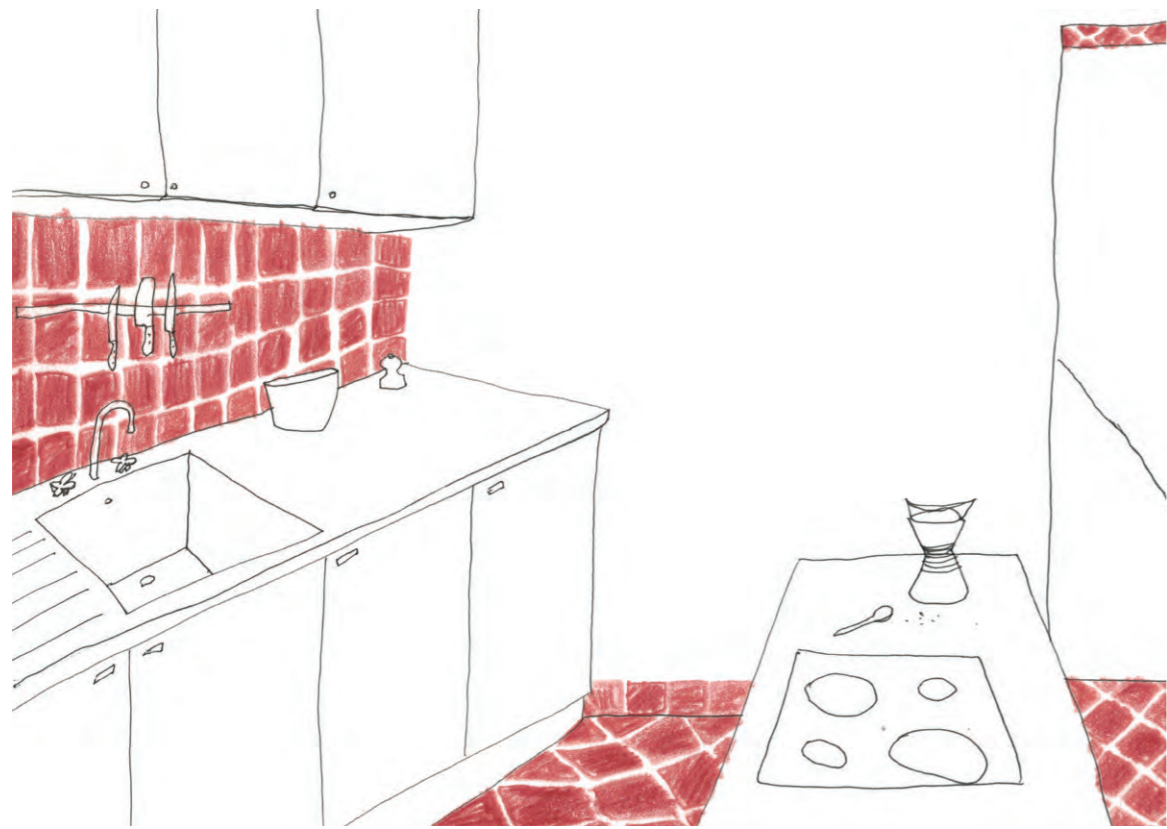

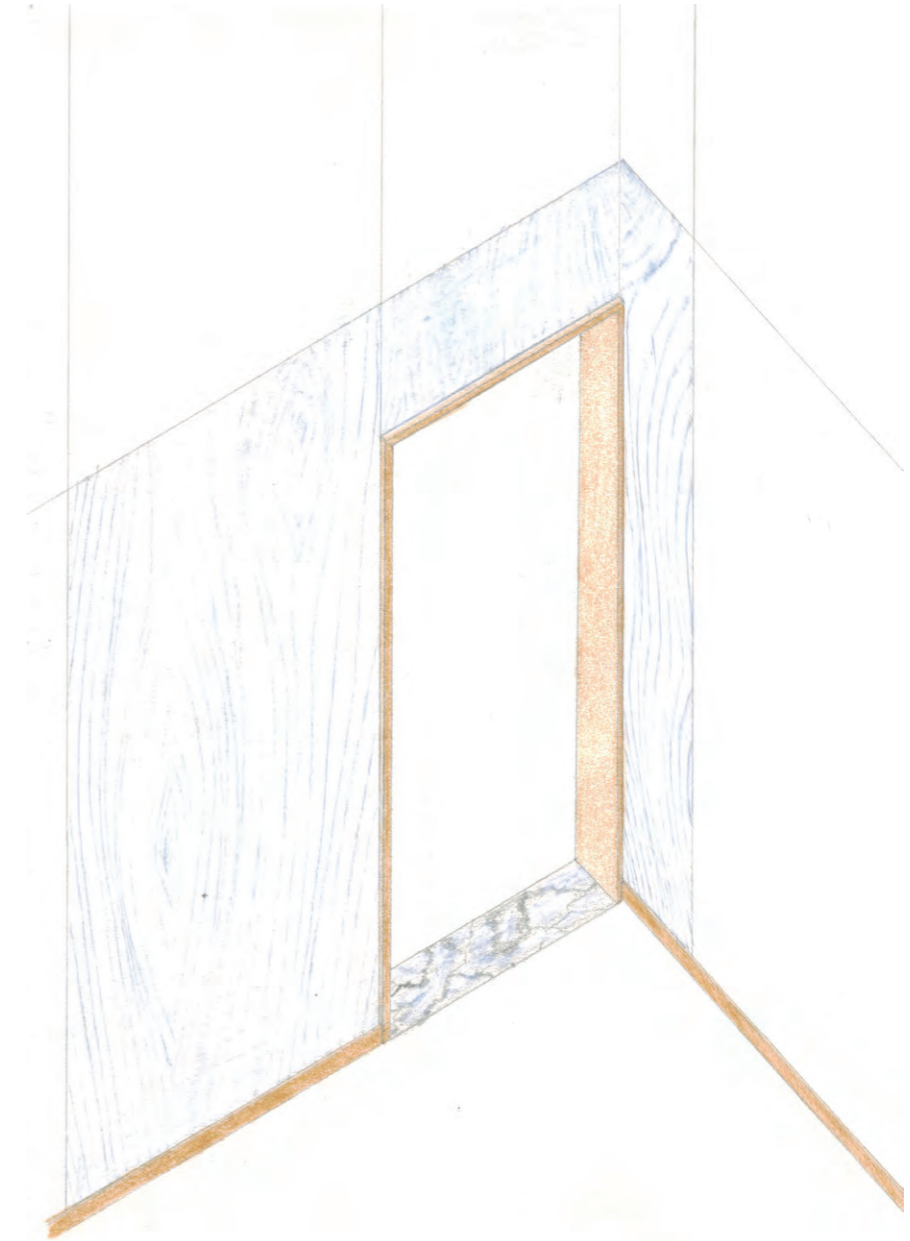
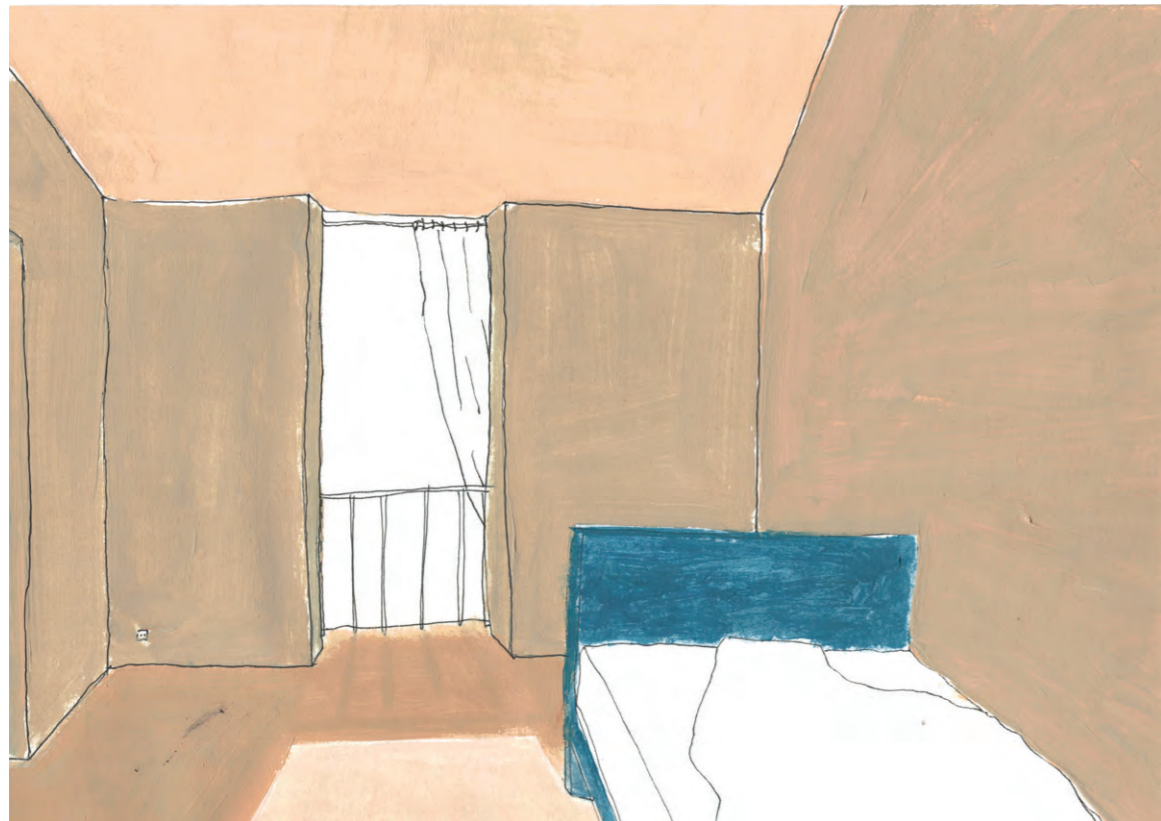

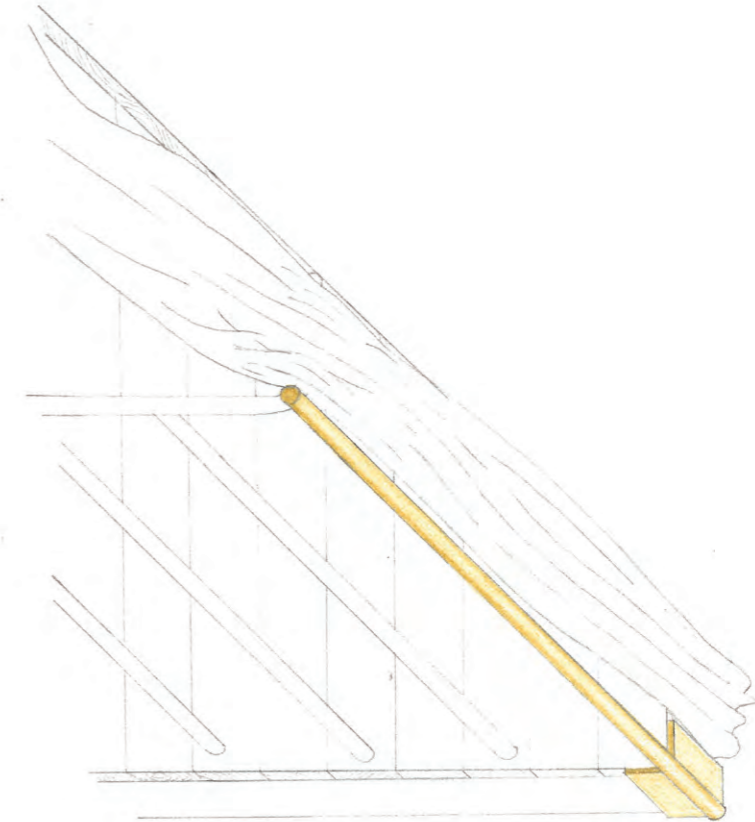

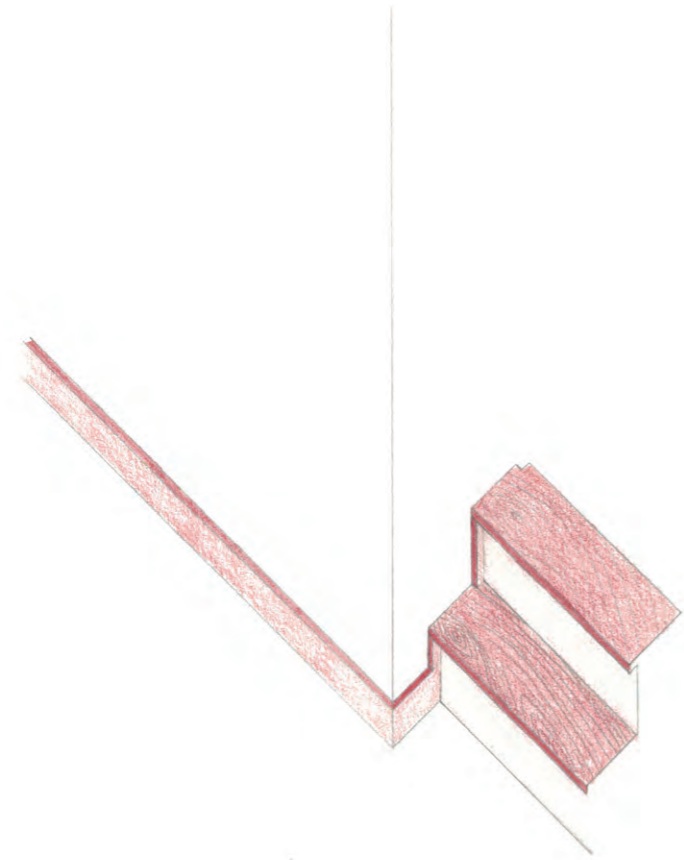

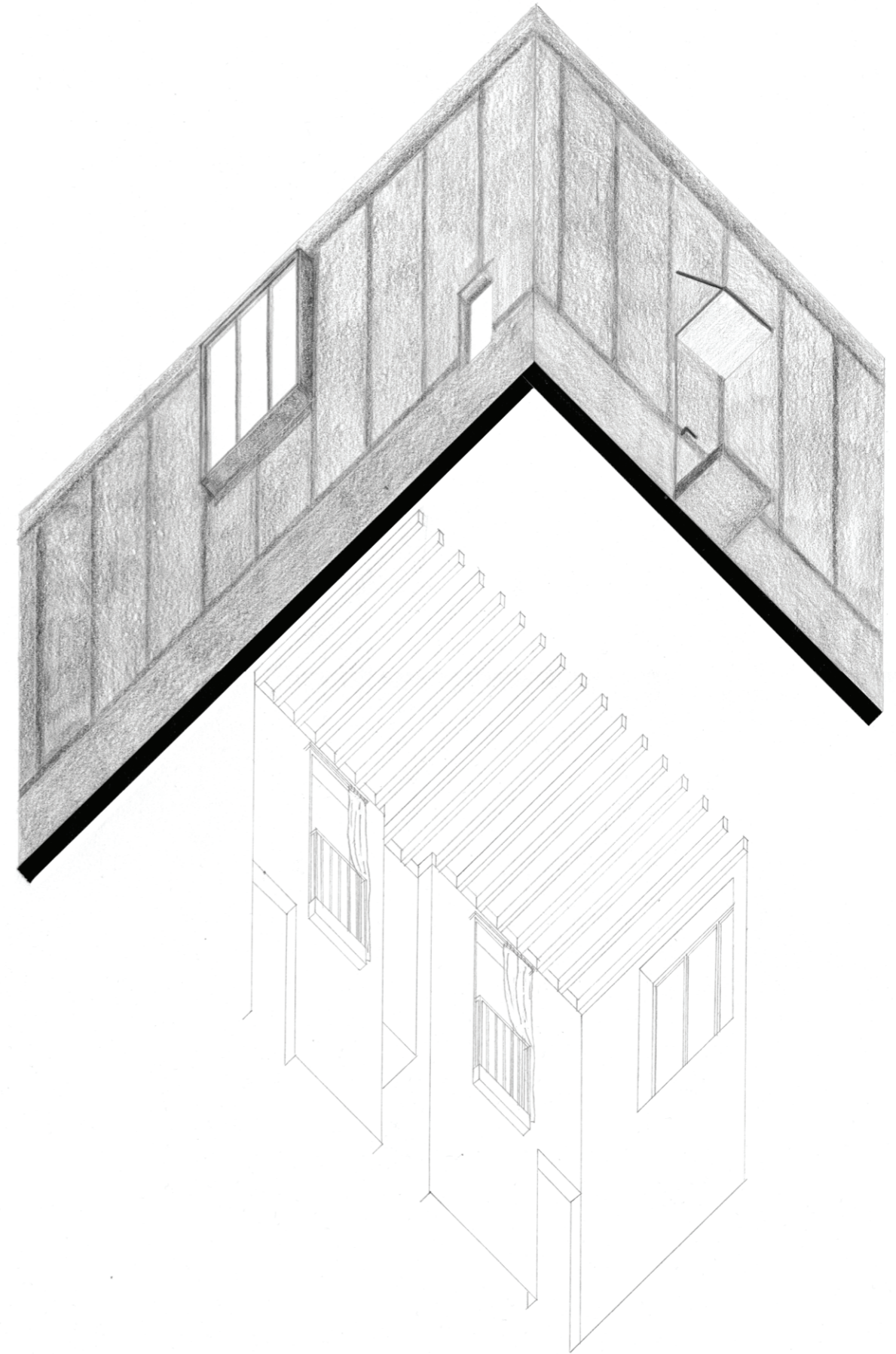
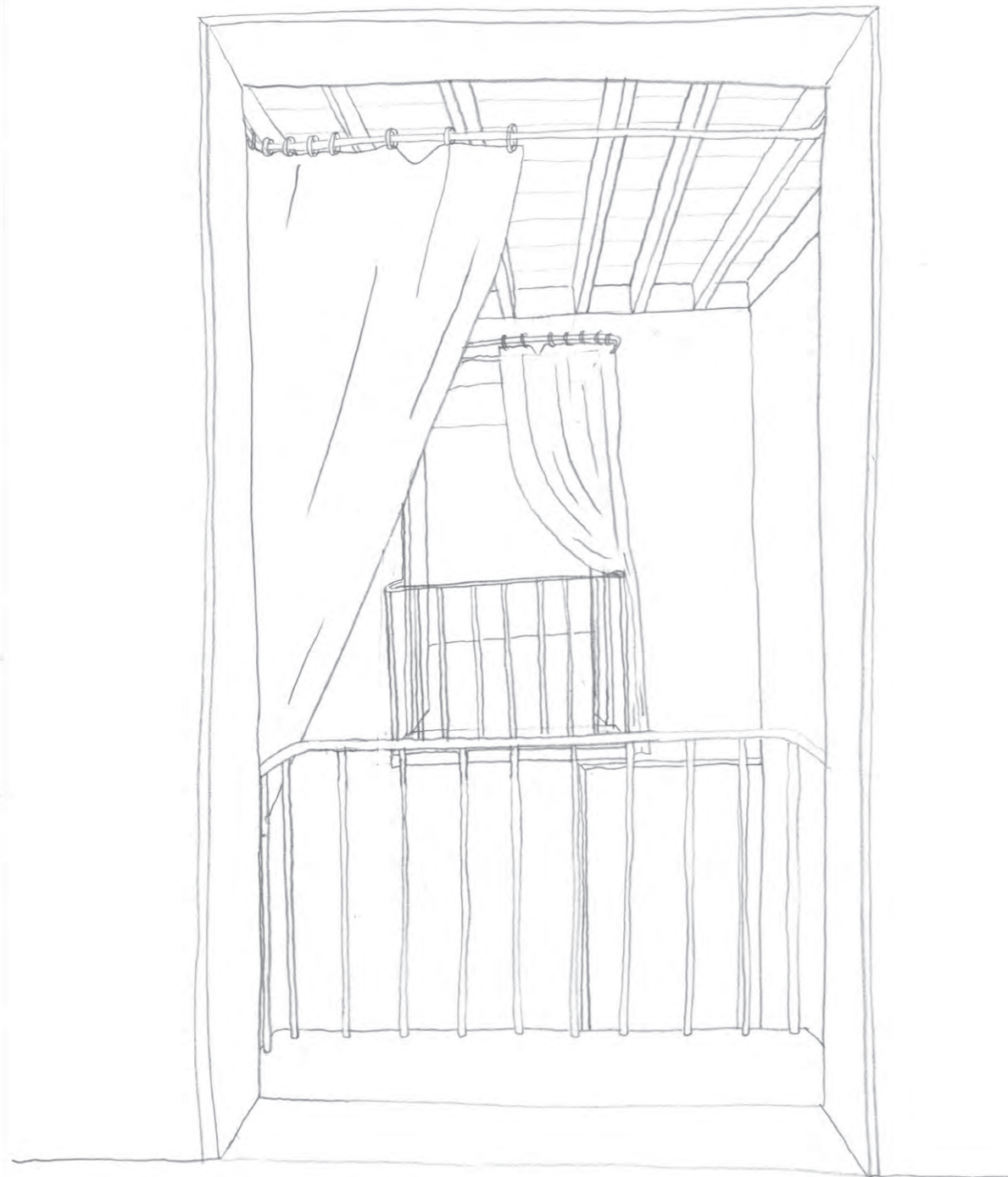

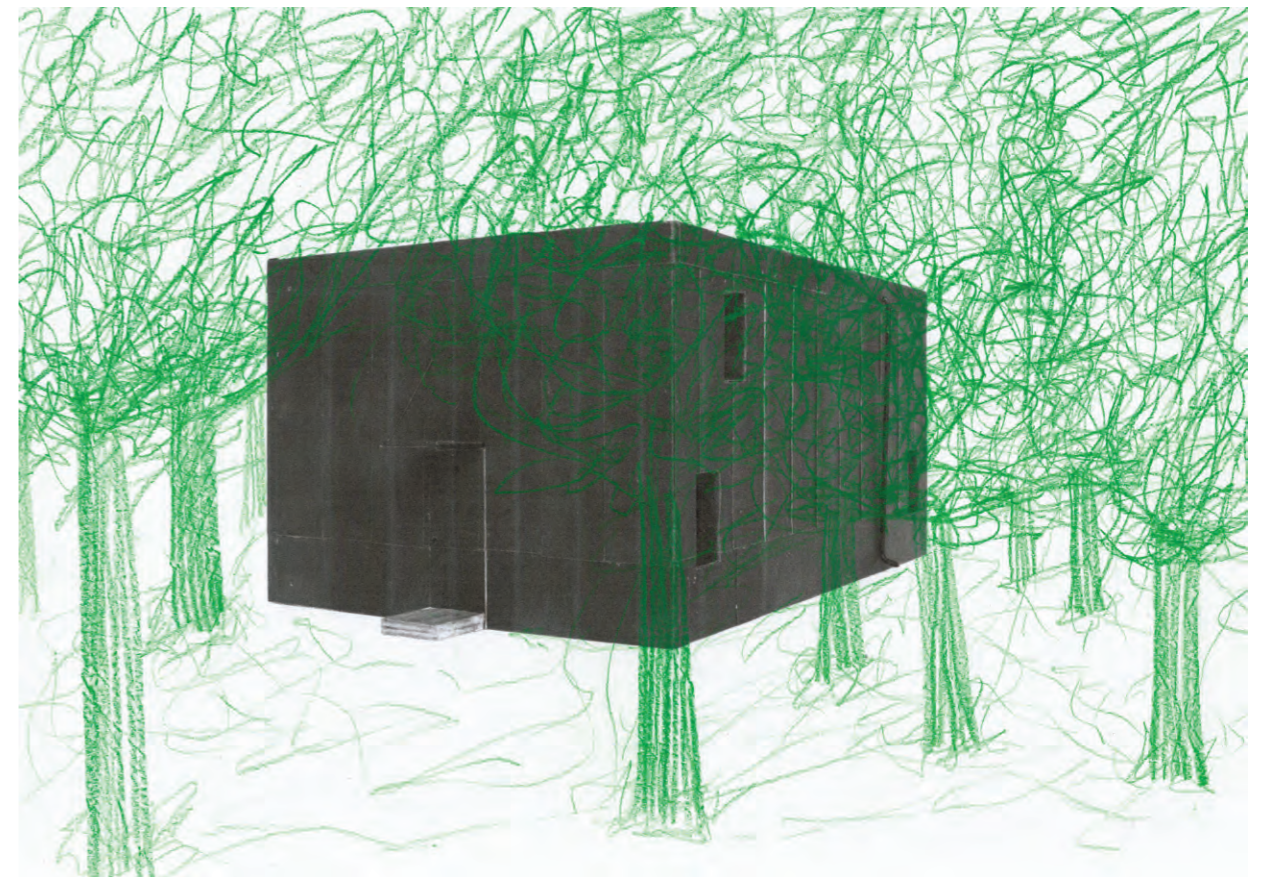
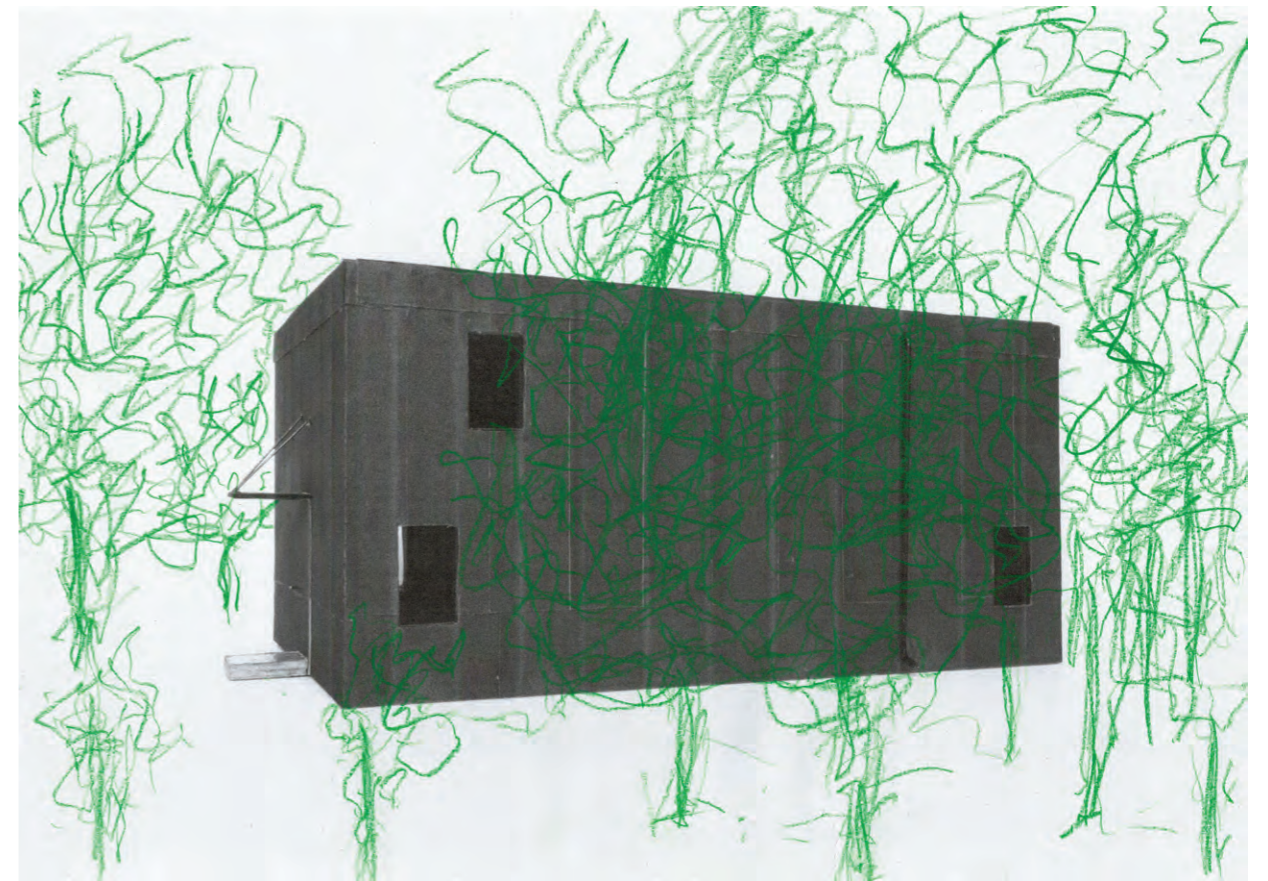
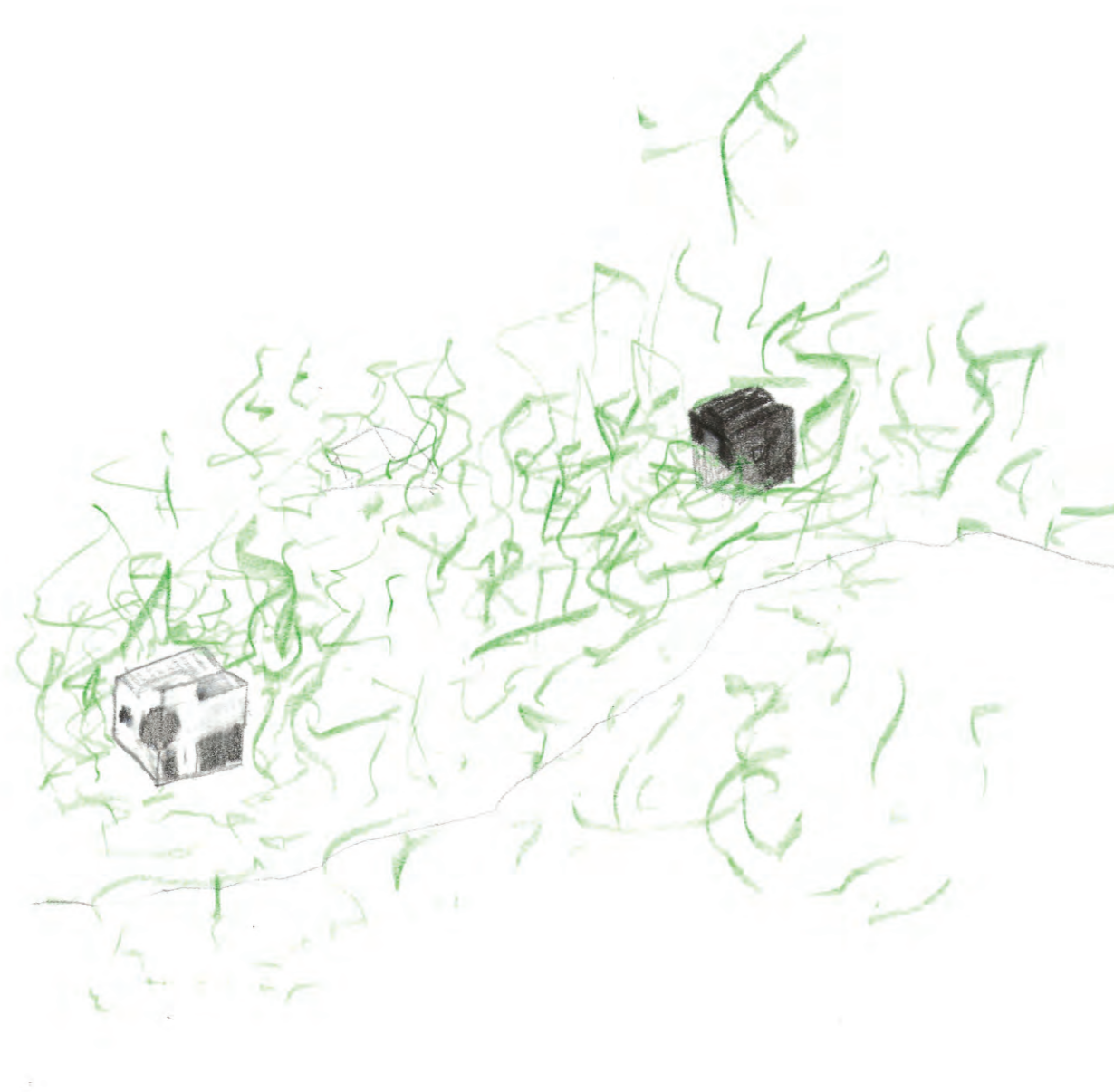

Movement 2

Switzerland

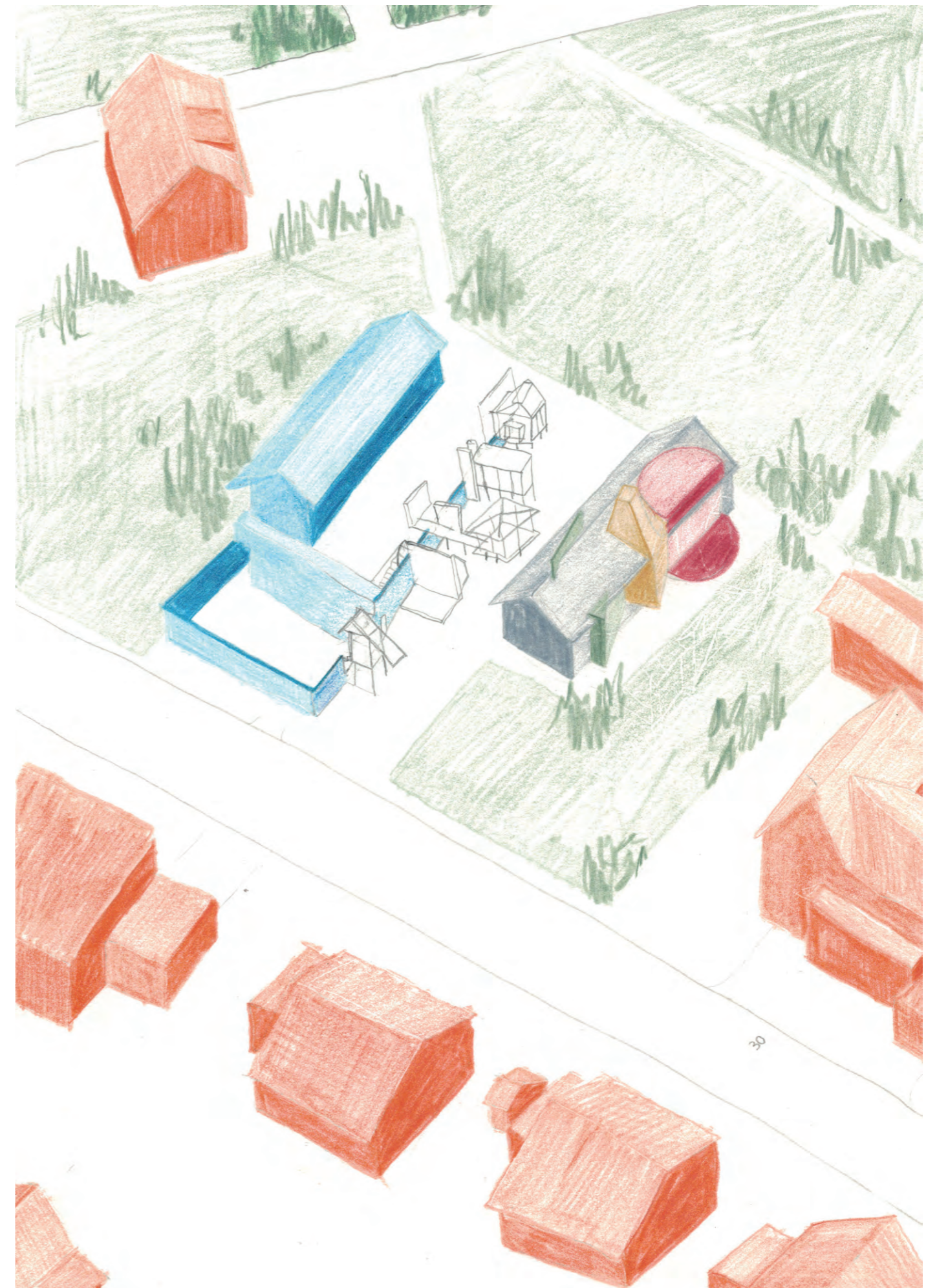

House de Wachter in the context of the House for an Art Collector (CH)

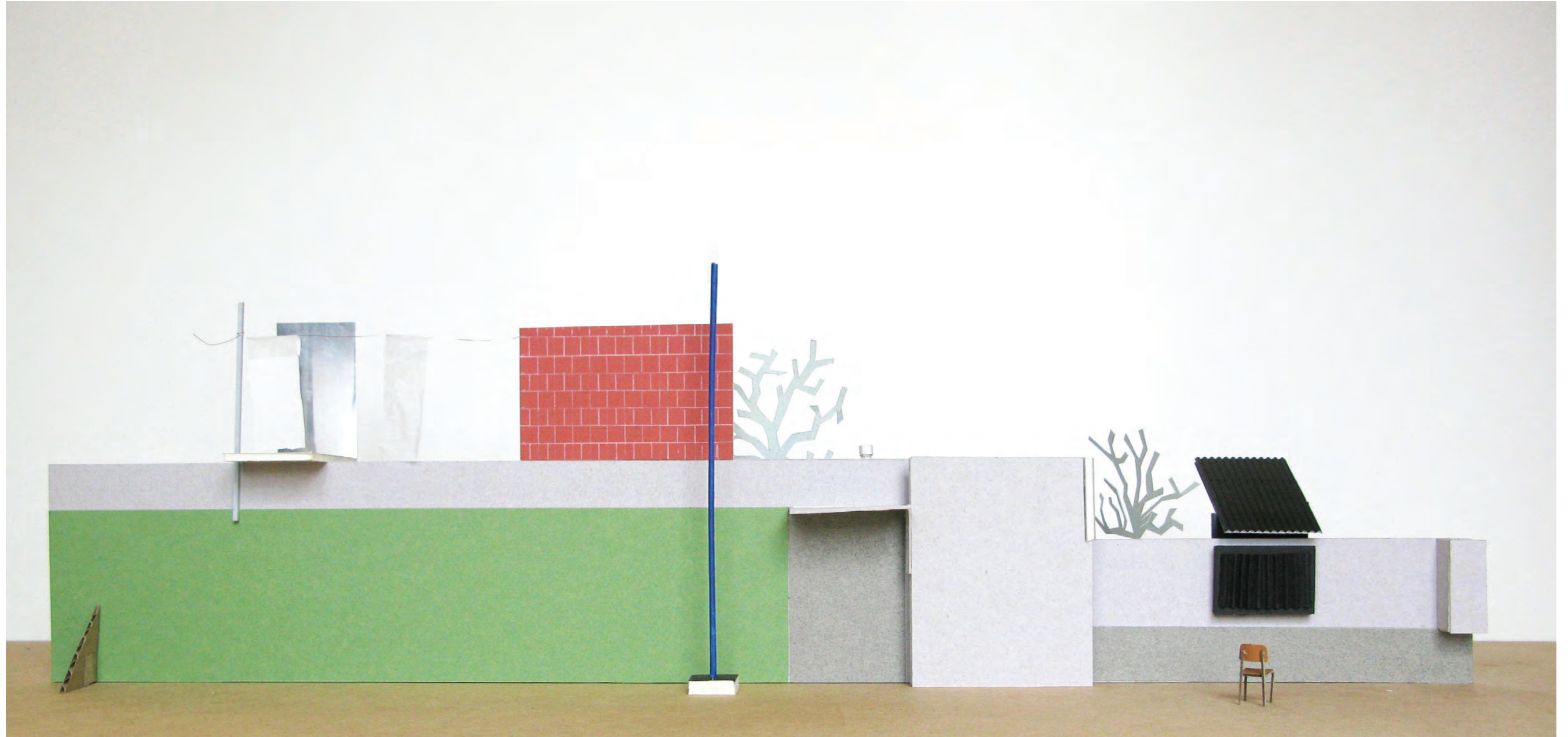

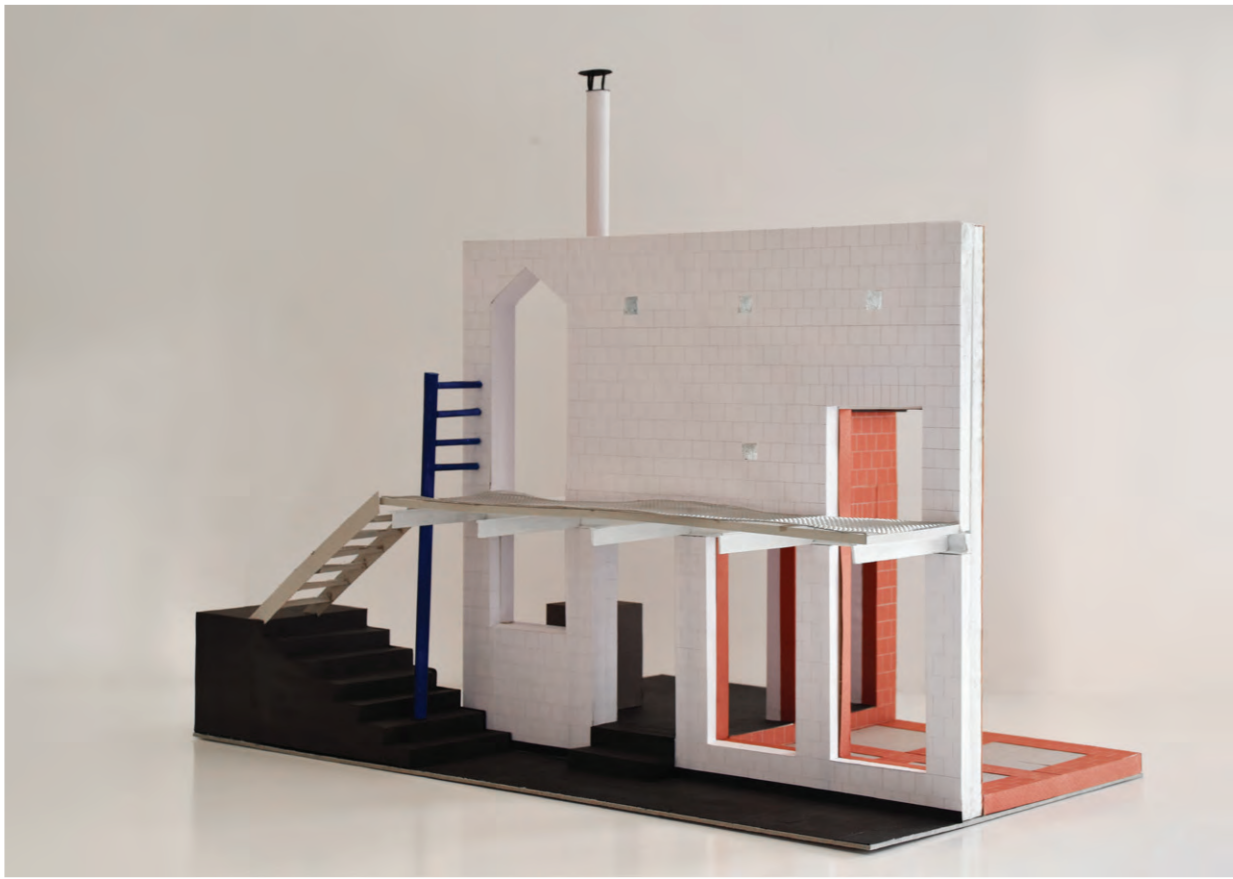

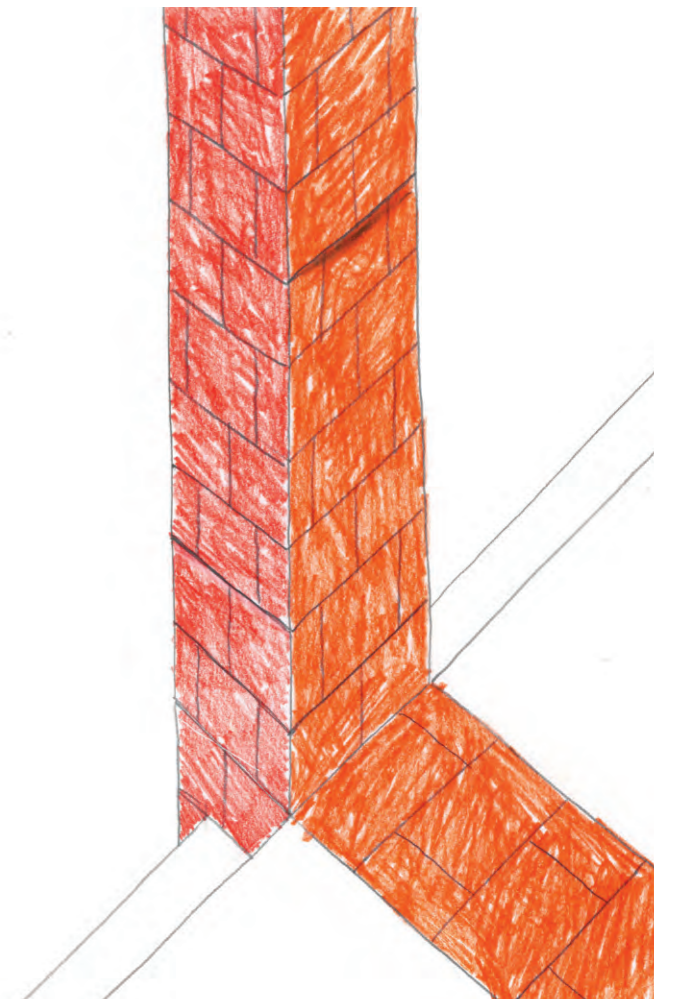
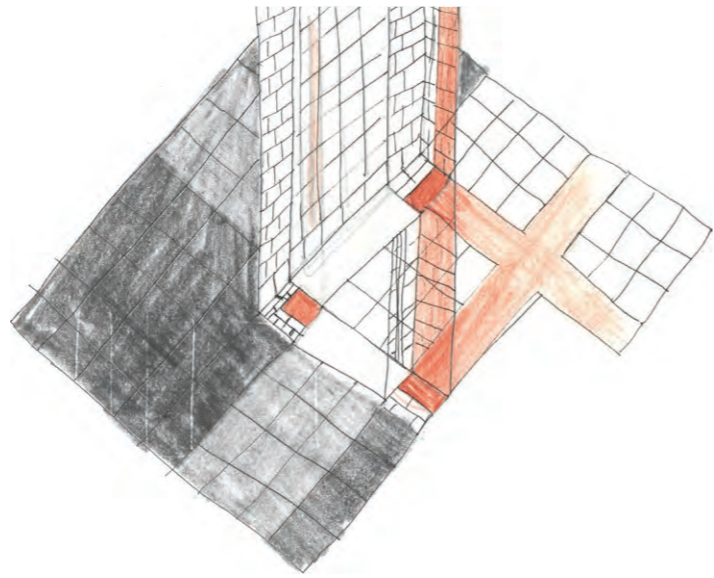
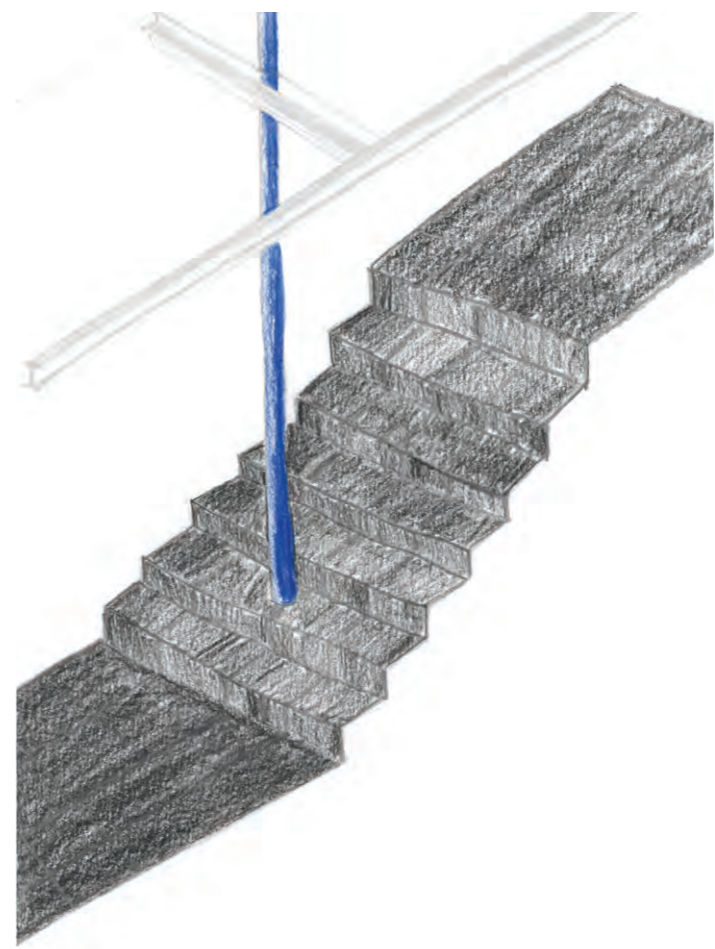
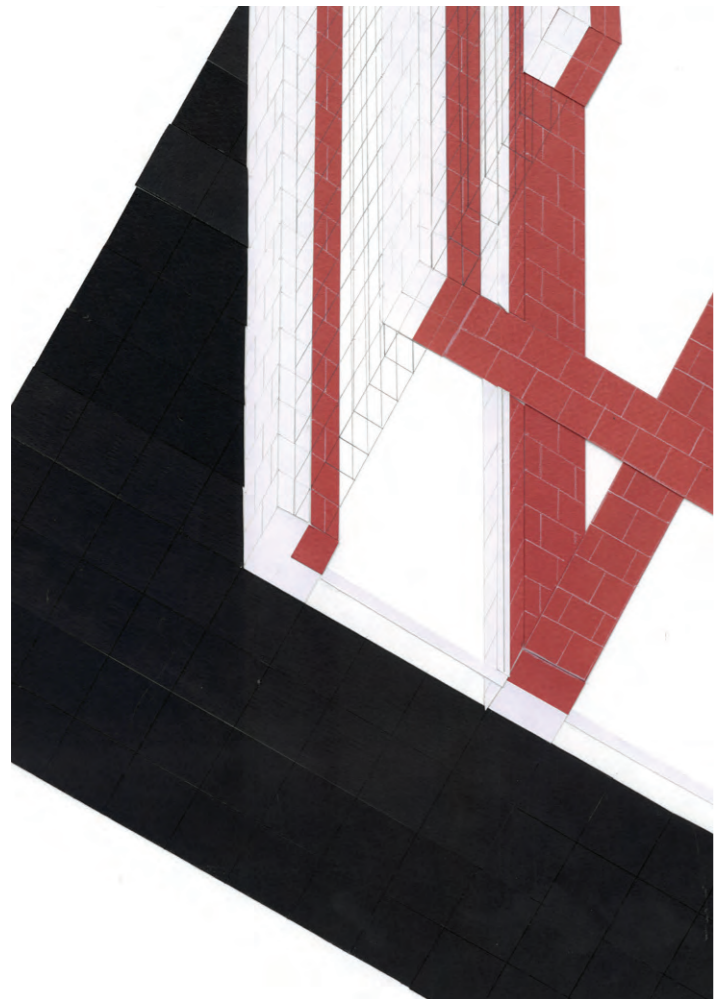

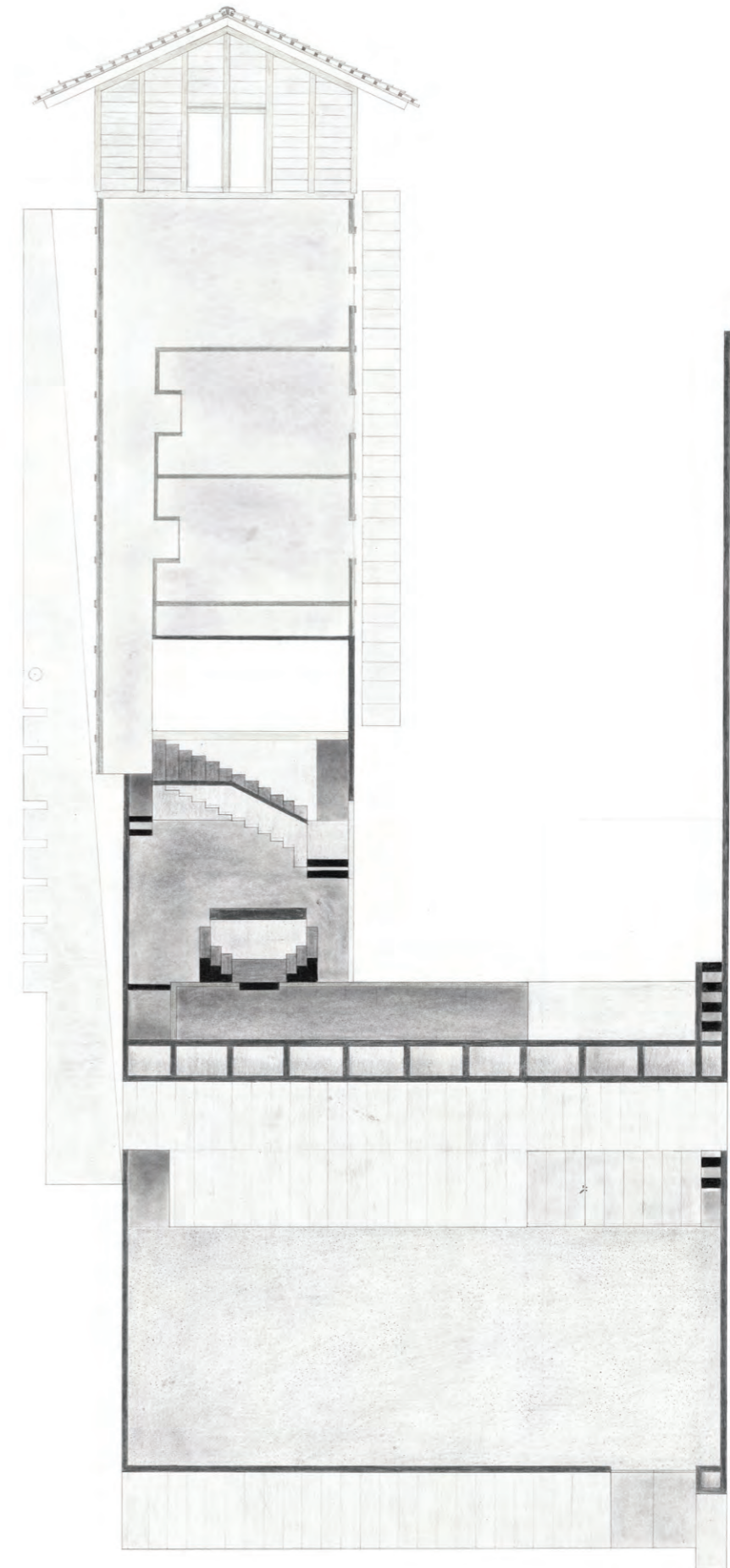

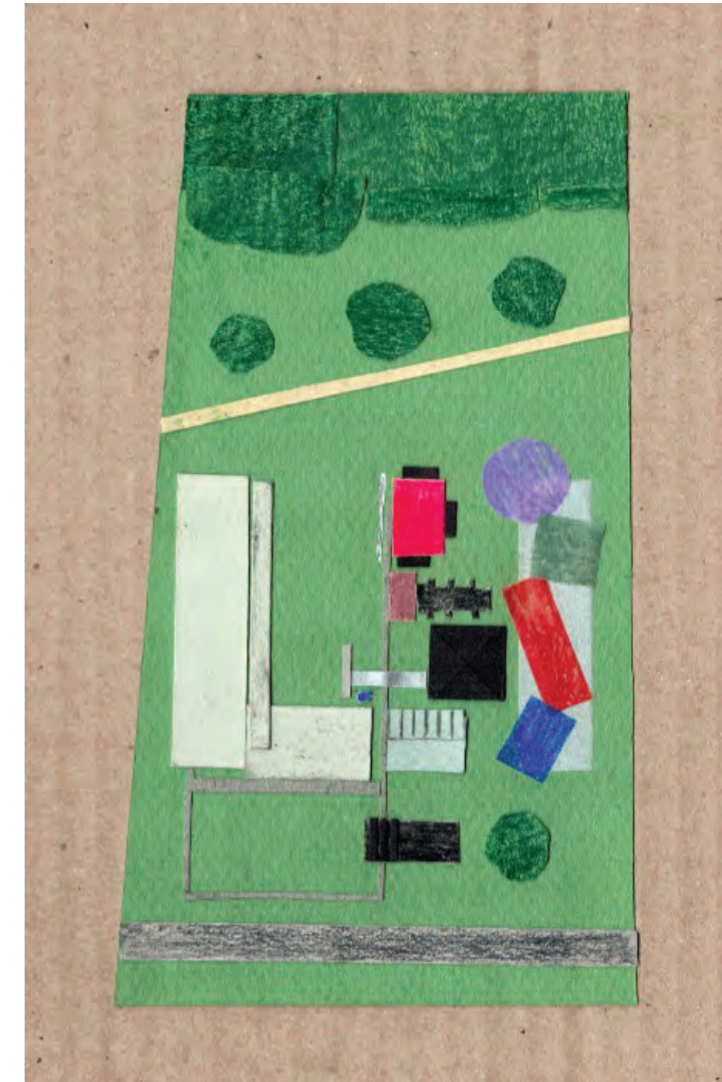
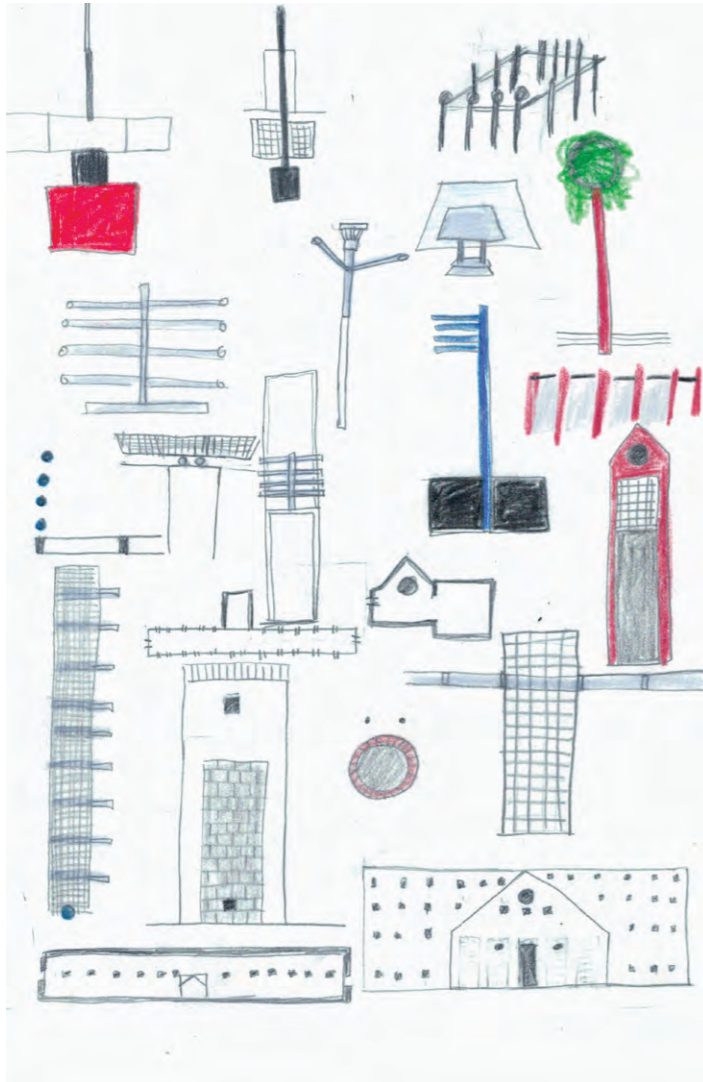

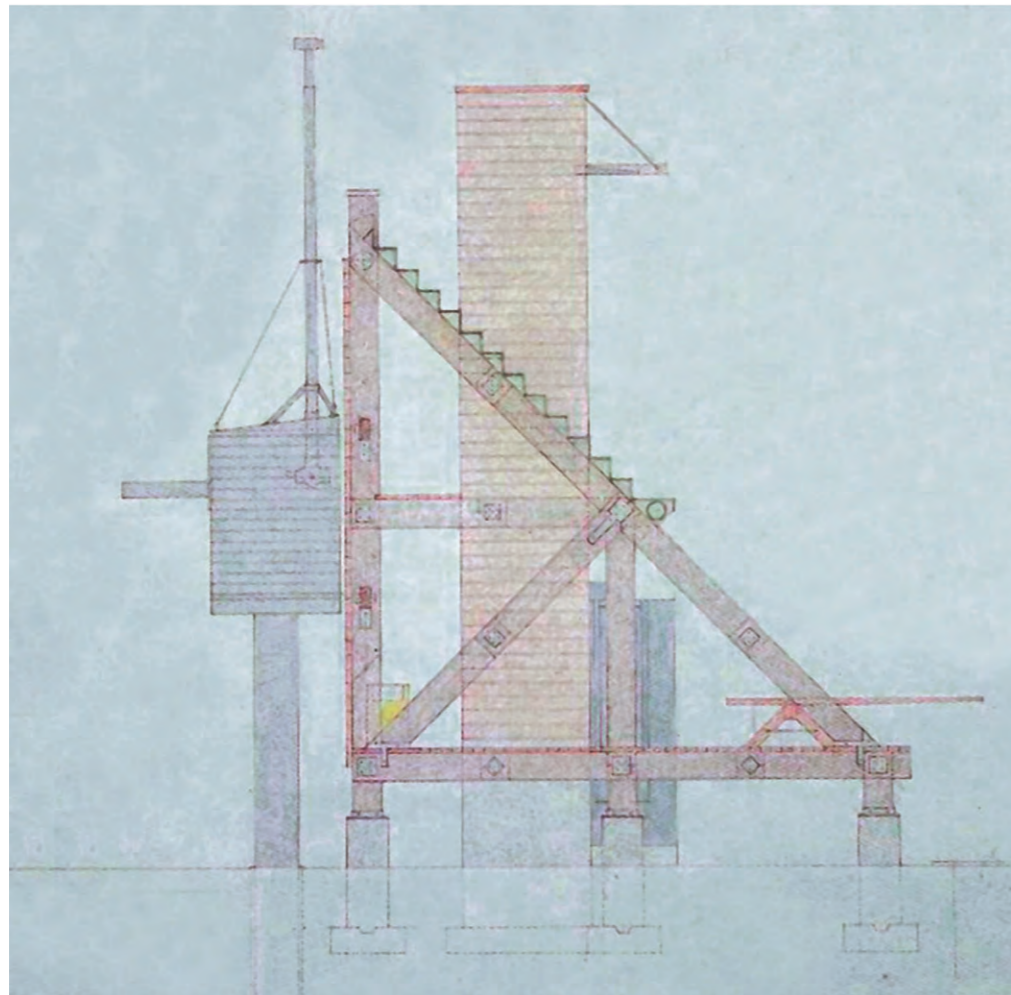

Mask of Medusa, 1998, Buenos Aires, John Hejduk



The Little Scientific Theatre, 1978, Aldo Rossi

The Act, the House

I mean, yes, many times it's a challenge. You have to manage to bring out two sides of yourself. On one hand controlled, you could say. Don't laugh too loud but be funny, talk to all the guests but don't be too accessible. What's the word I'm looking for...mysterious, maybe. And on the other hand...It's more about being personal. Let loose, don't limit yourself. You know, "let people see your true self, without being scared of what they might think". Eat your dinner naked on the sofa, don't hide anything. You meet new people on a daily basis and sometimes that's tiring, of course, but never boring. In the end it's a job, I have to think about that. And who I really am when I get home.



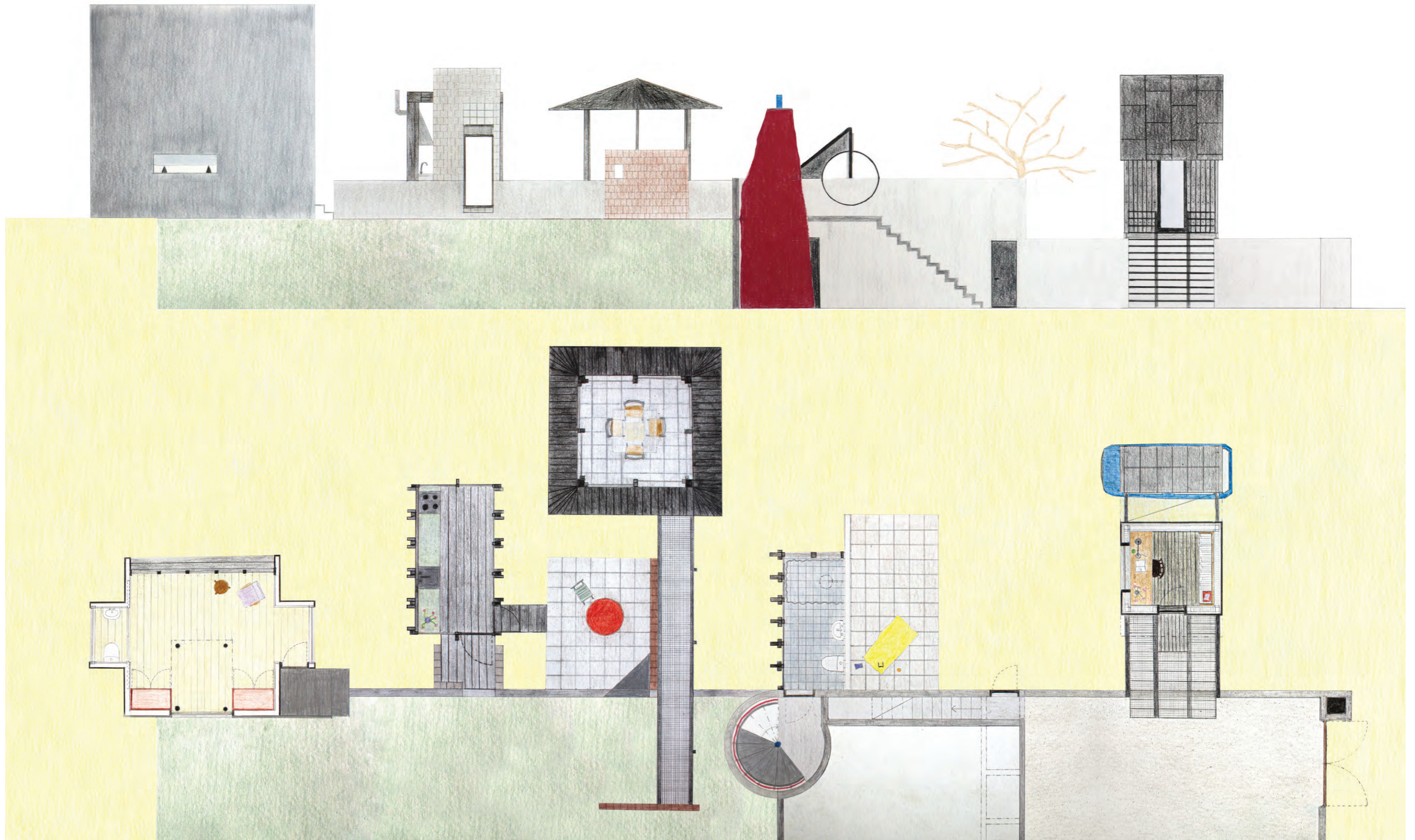

ACT ONE

Something falls to the floor .
A person stumbles slightly when getting
up from the chair.
Places the perfectly green, lucid apple
on the table again.

End of Act One.



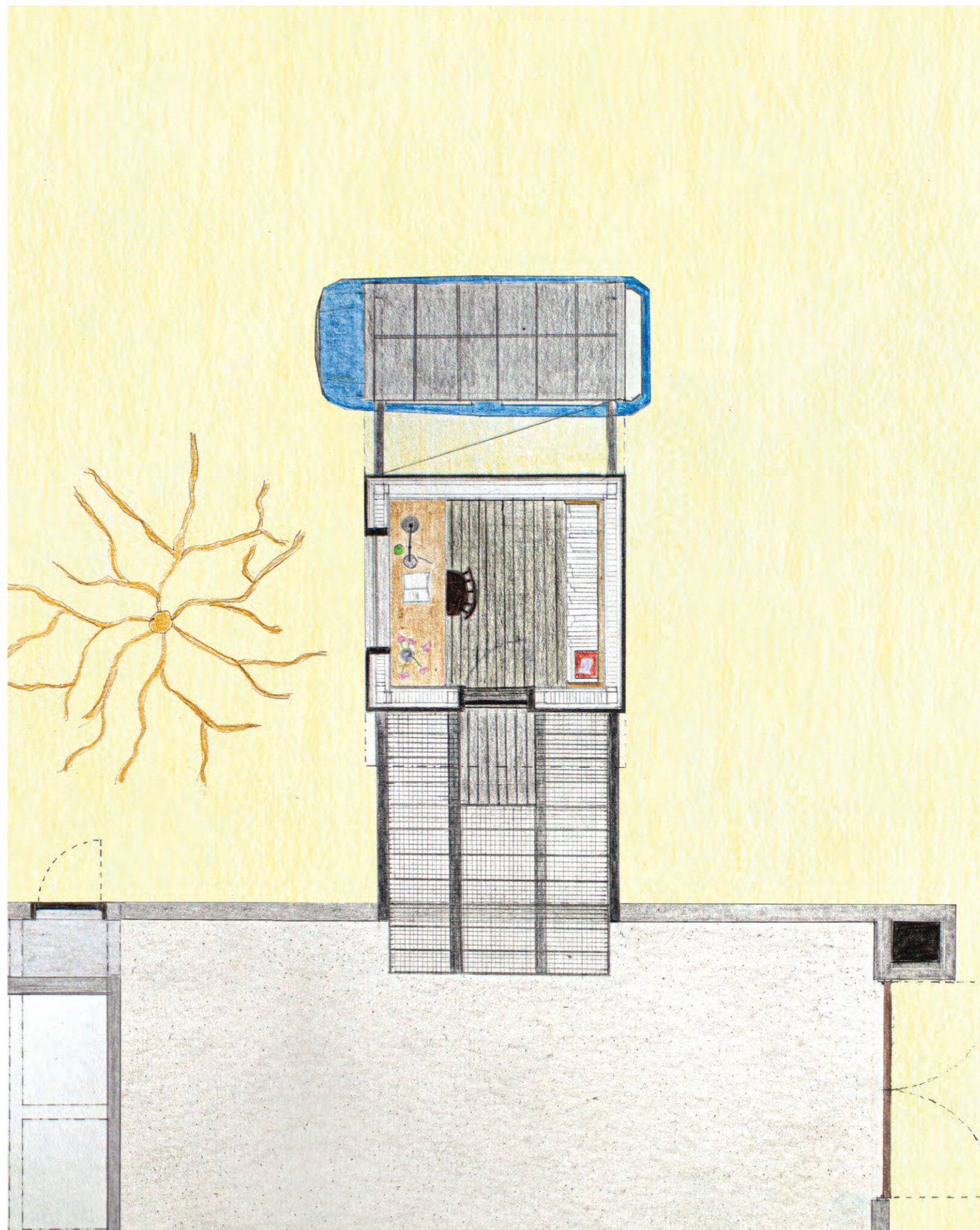



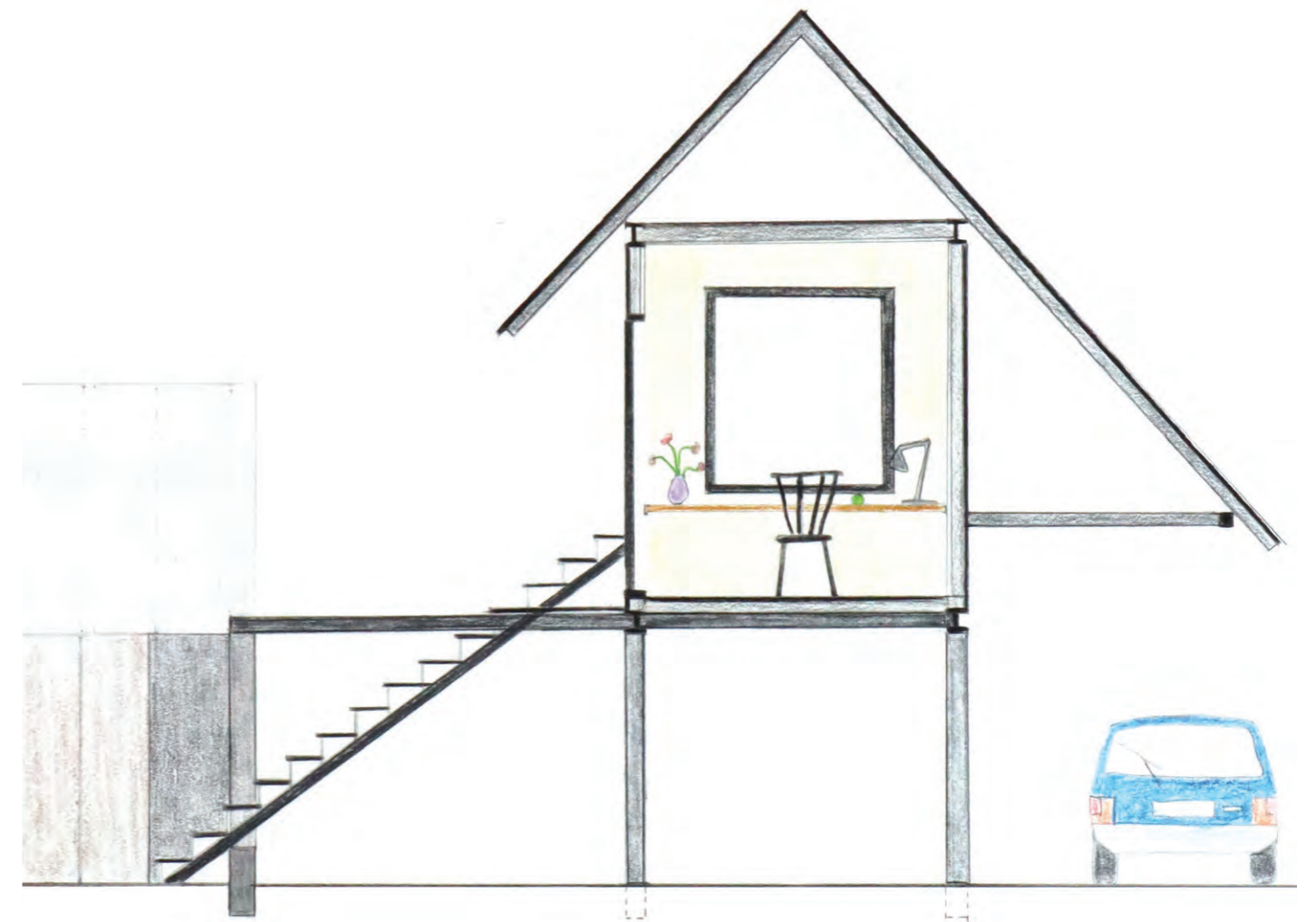
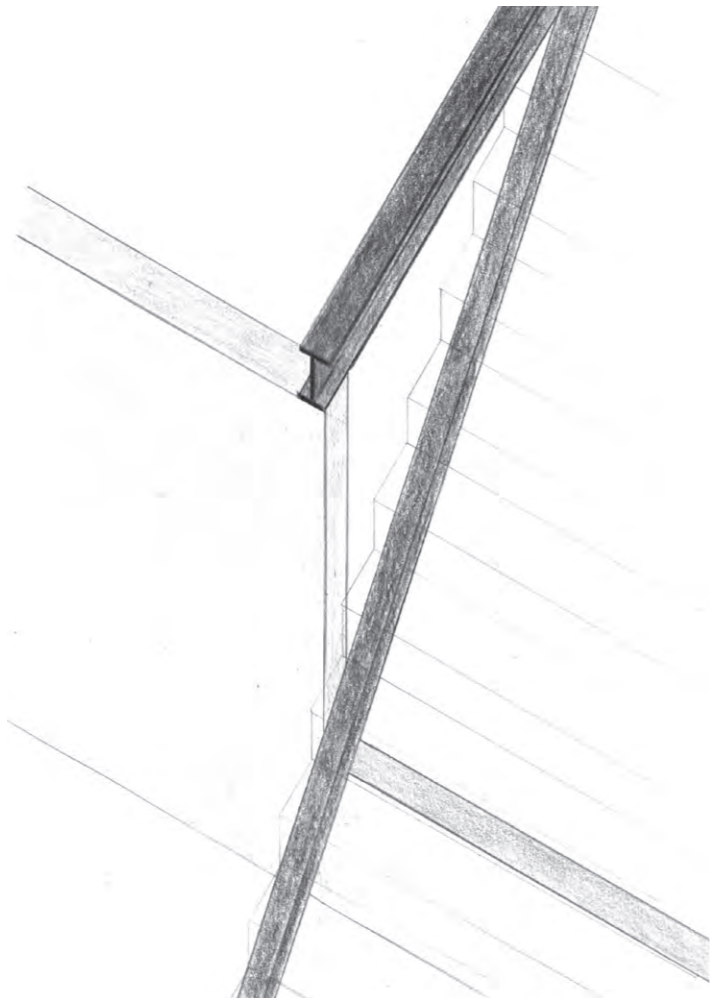

ACT TWO

Steam rises from below onto the windows.
A curtain opens.
Wet hair in a yellow towel.

End of Act Two.



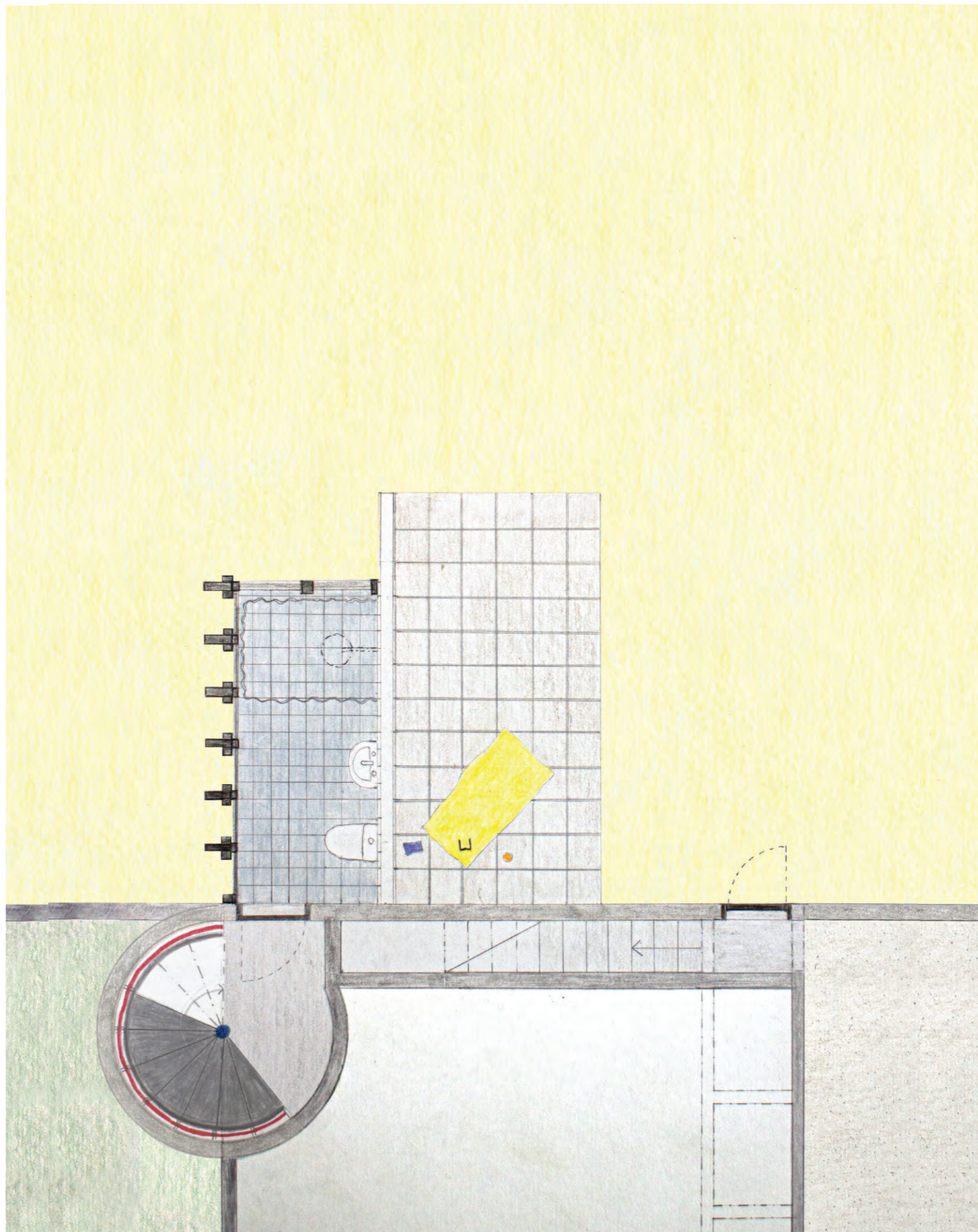

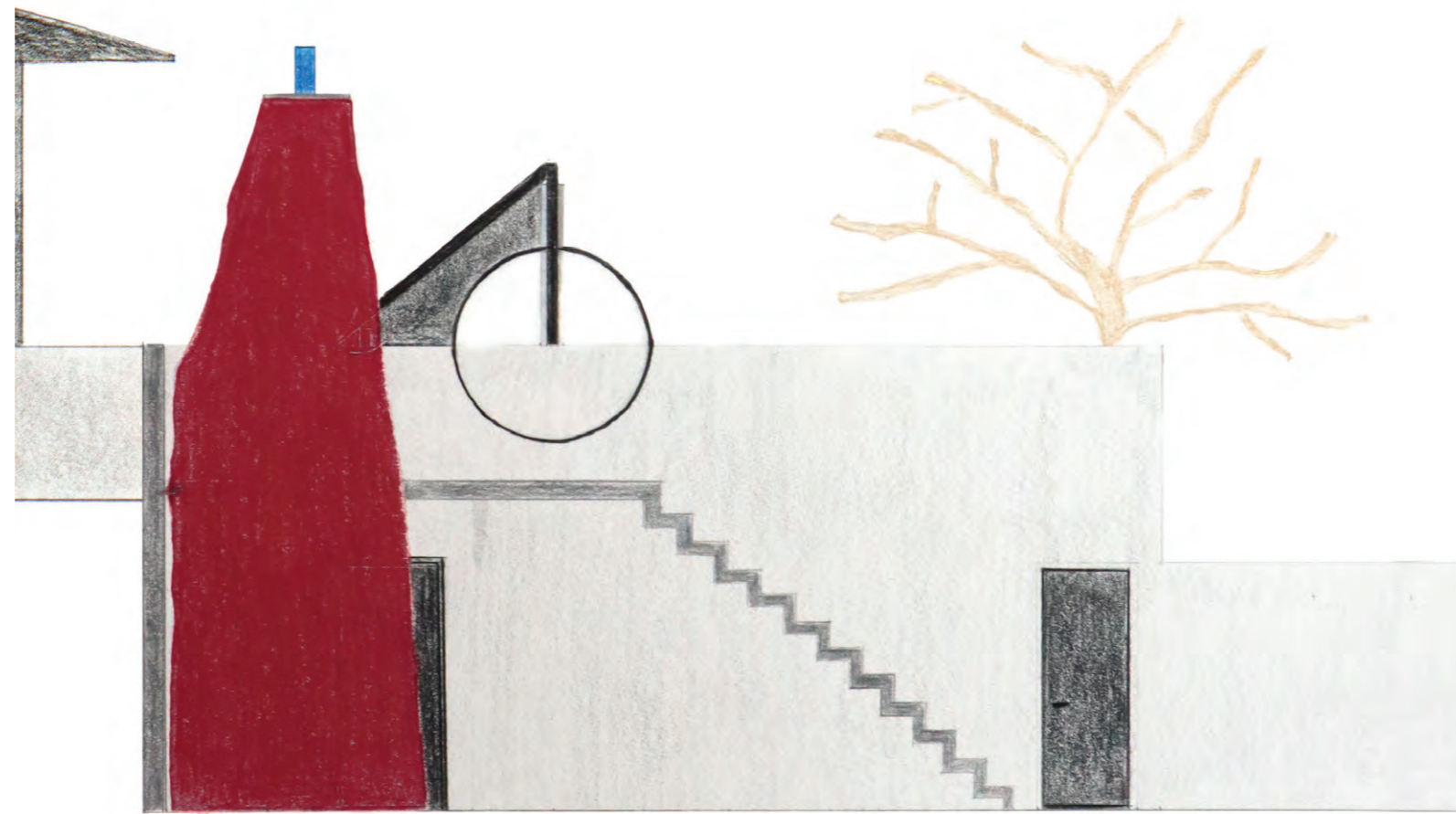

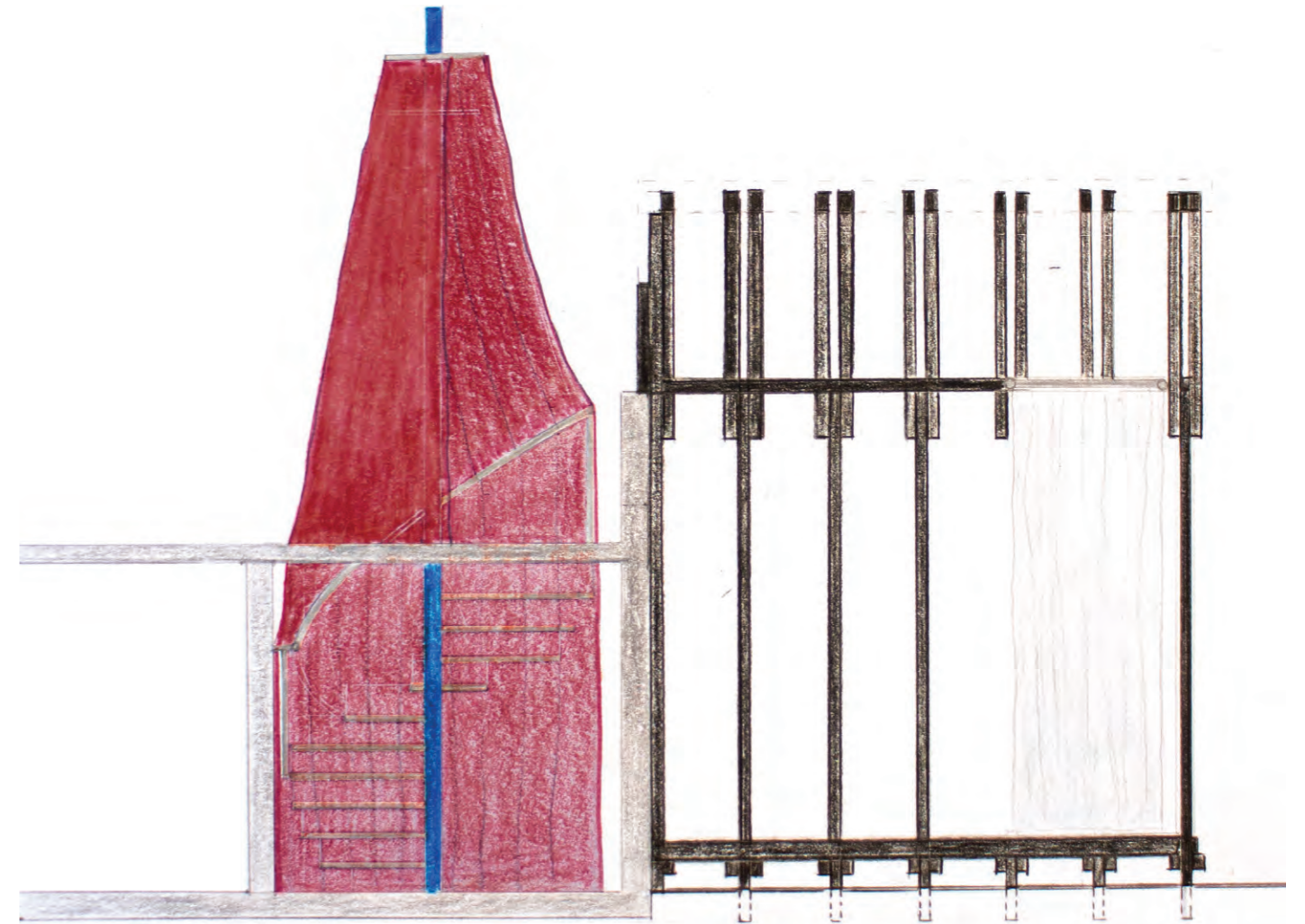
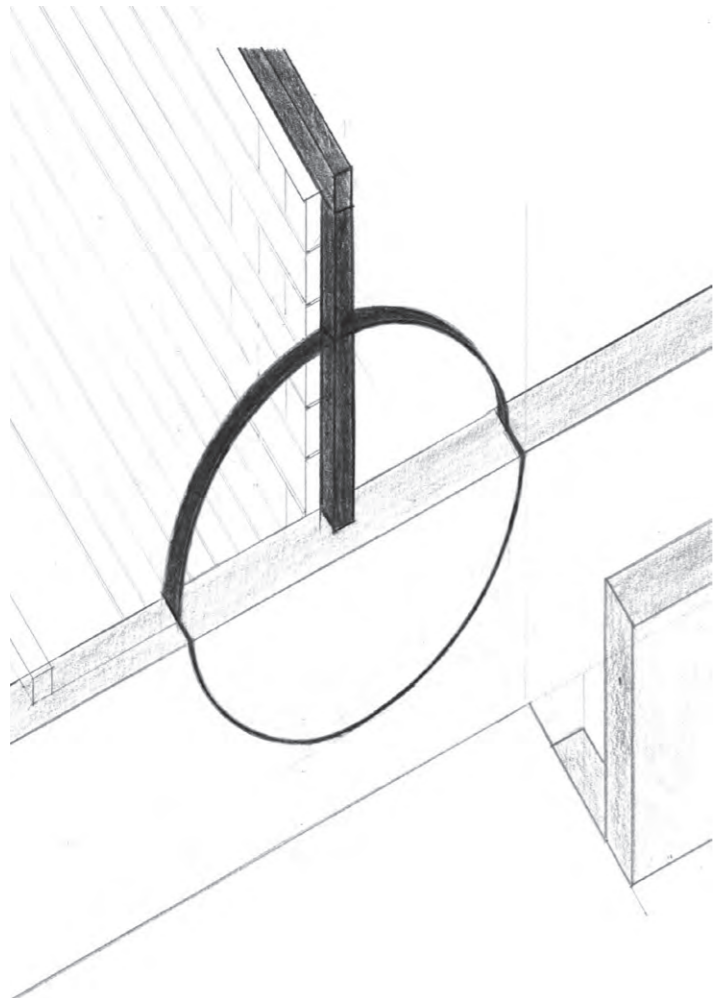

ACT THREE

**Legs touching.
Metal so close to each other, with on top the
remains of a large meal.**

End of Act three.



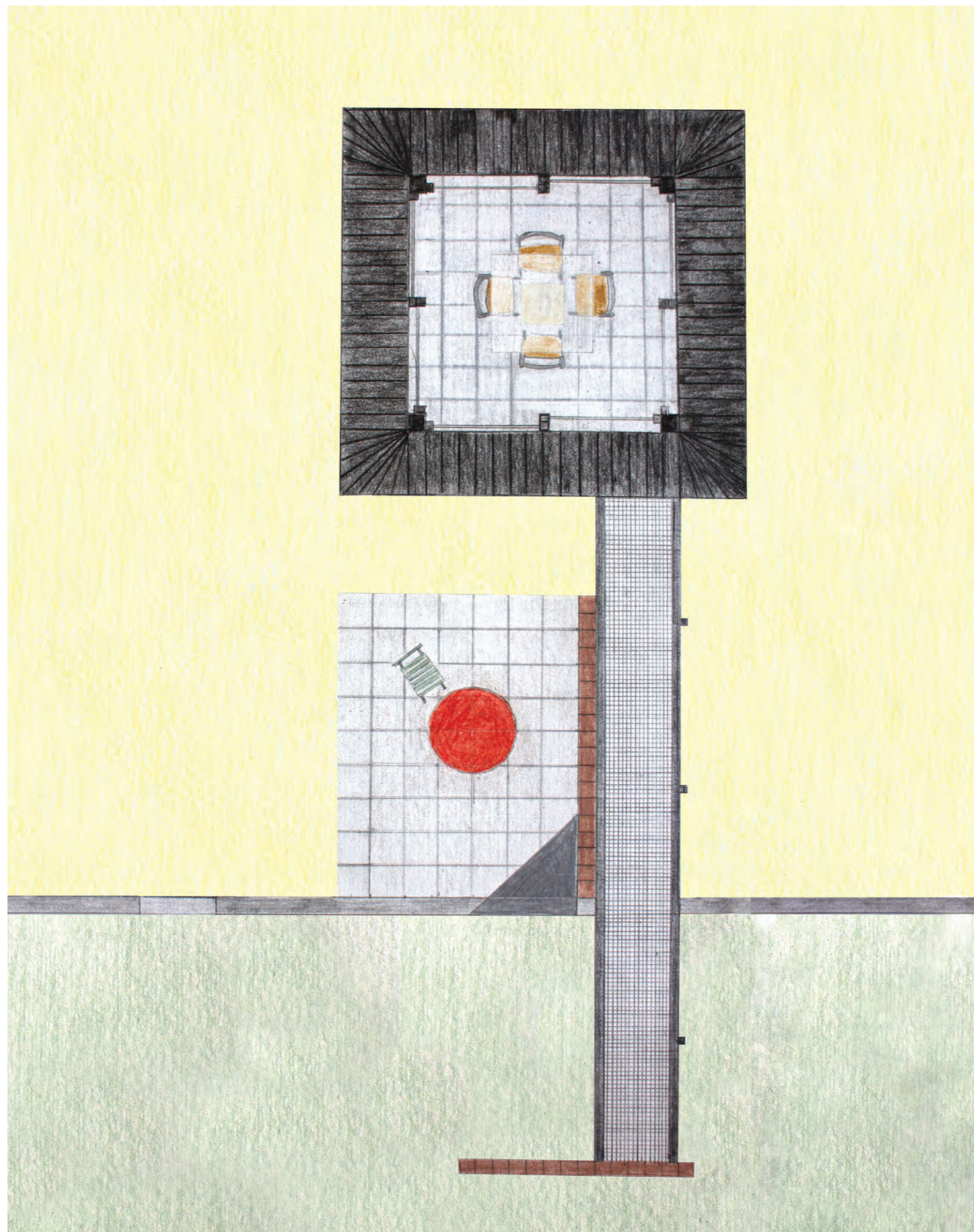

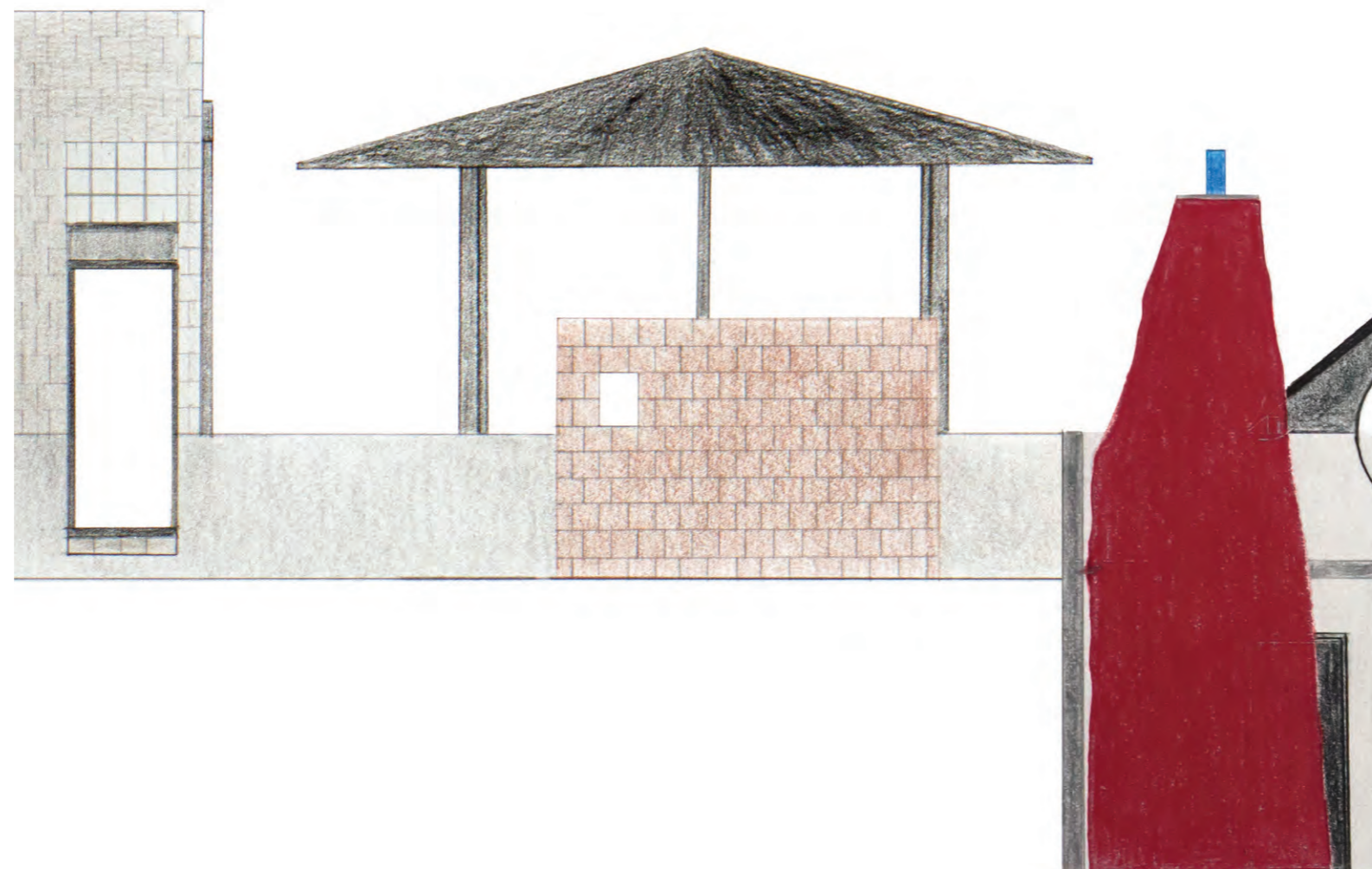

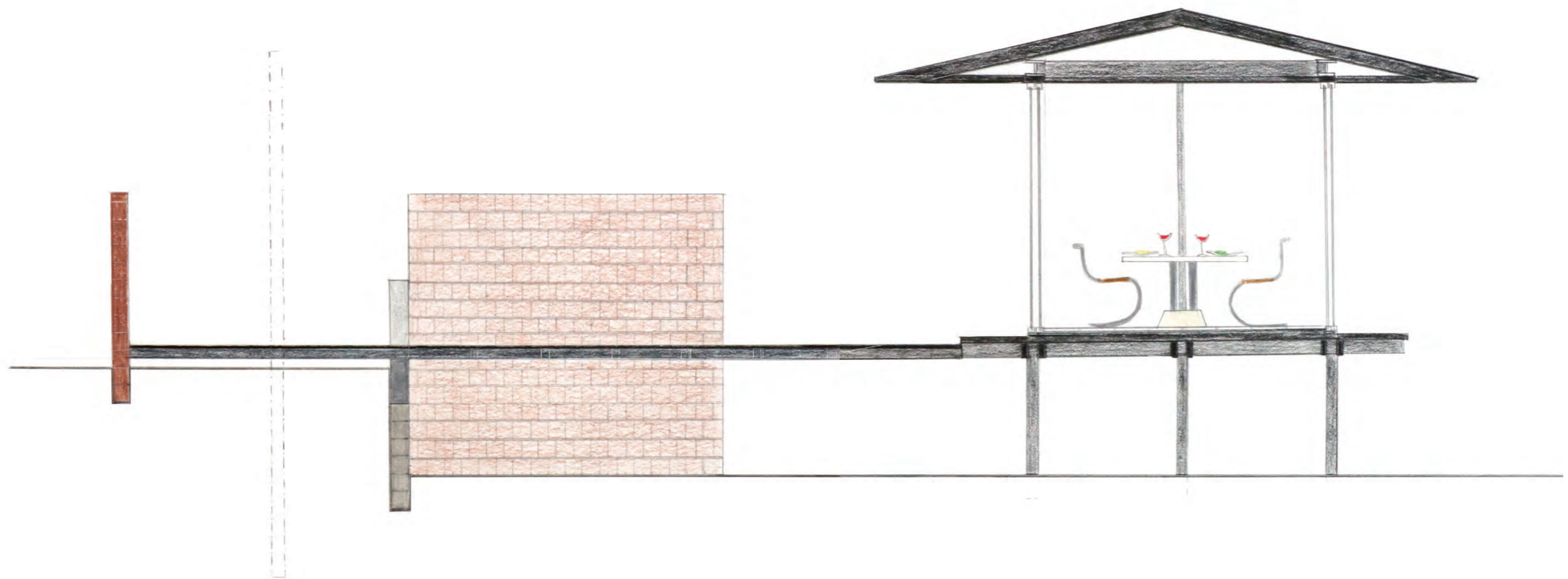

ACT FOUR

**Water running.
Water still running.
Two hands in the sink.**

End of Act four.



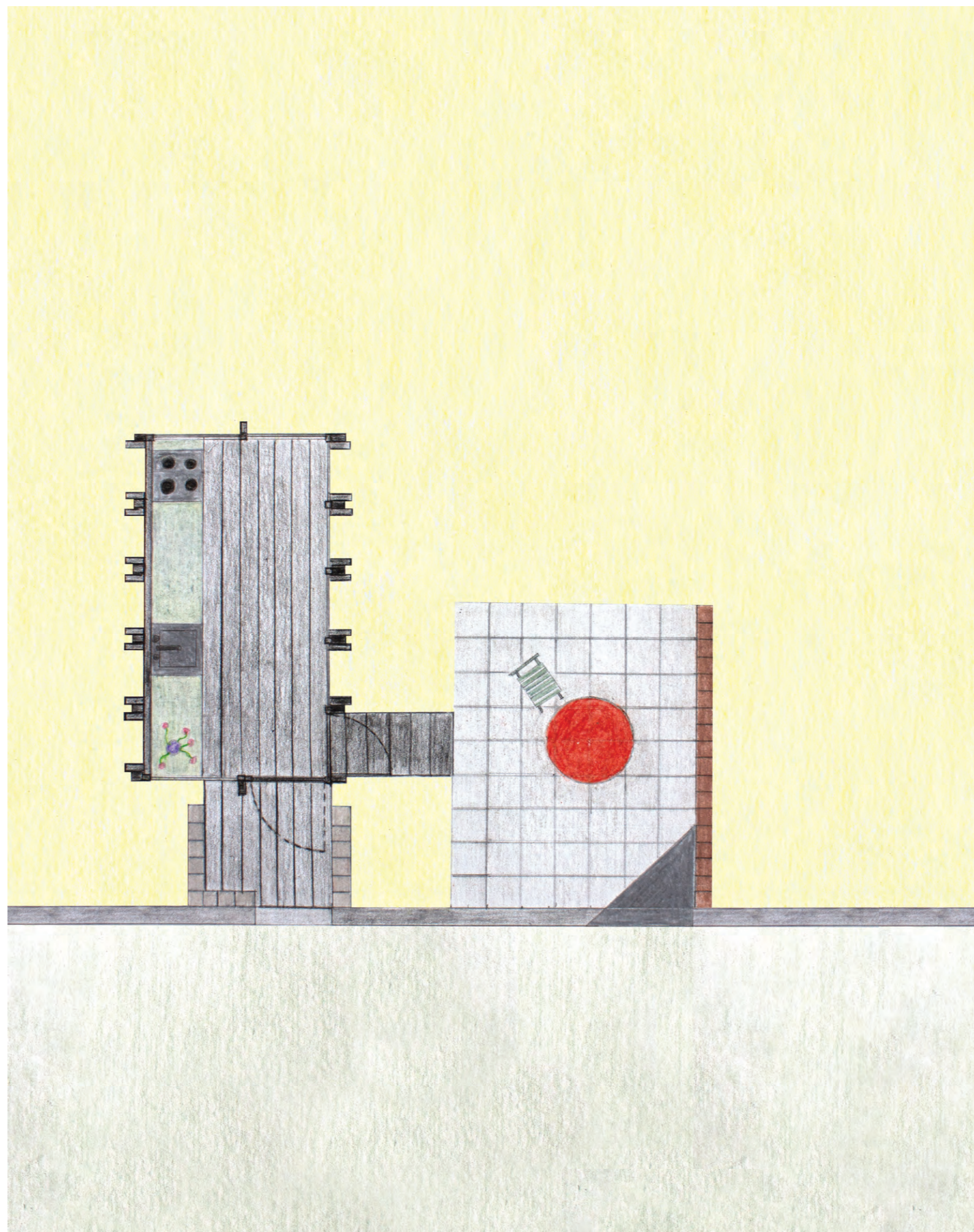

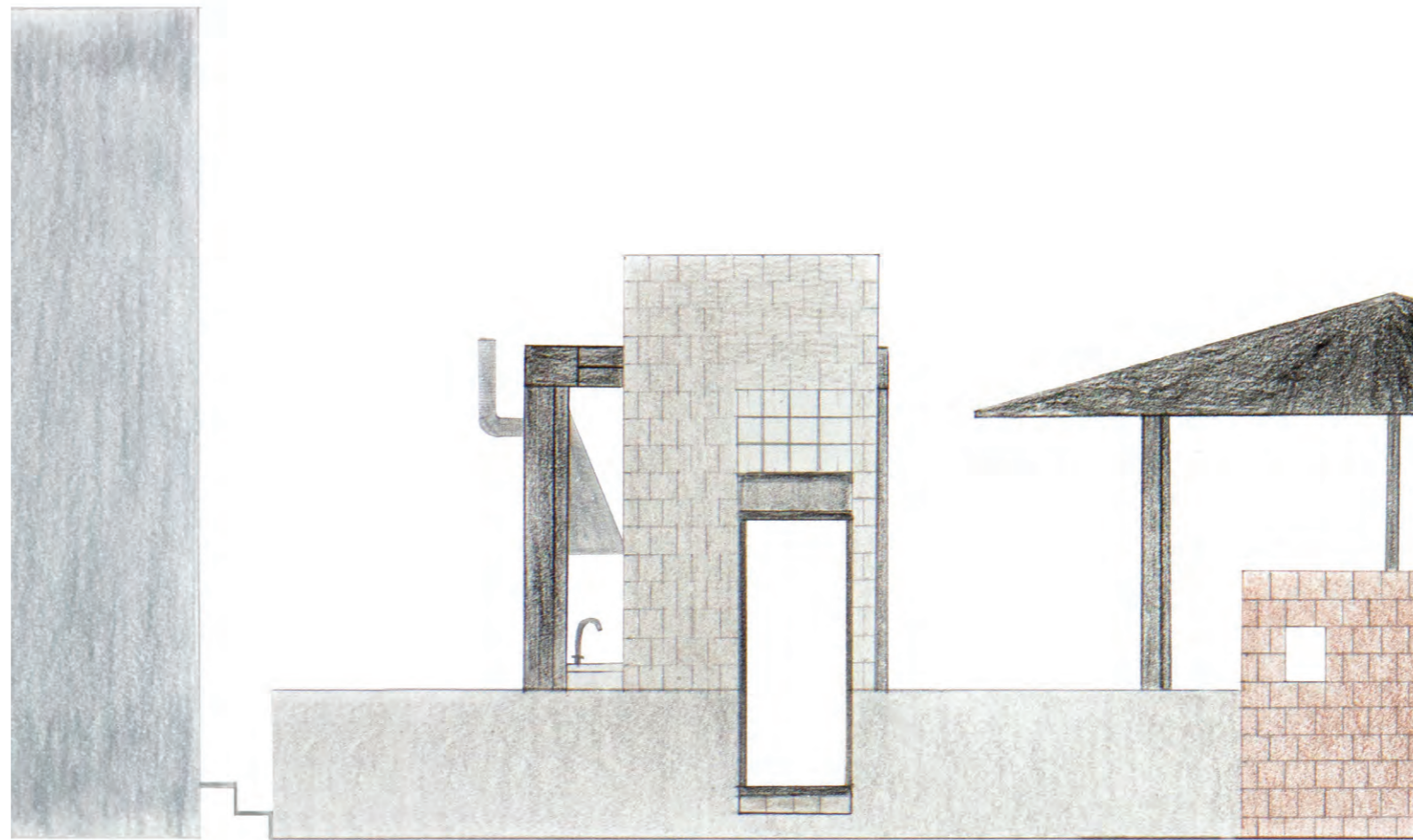

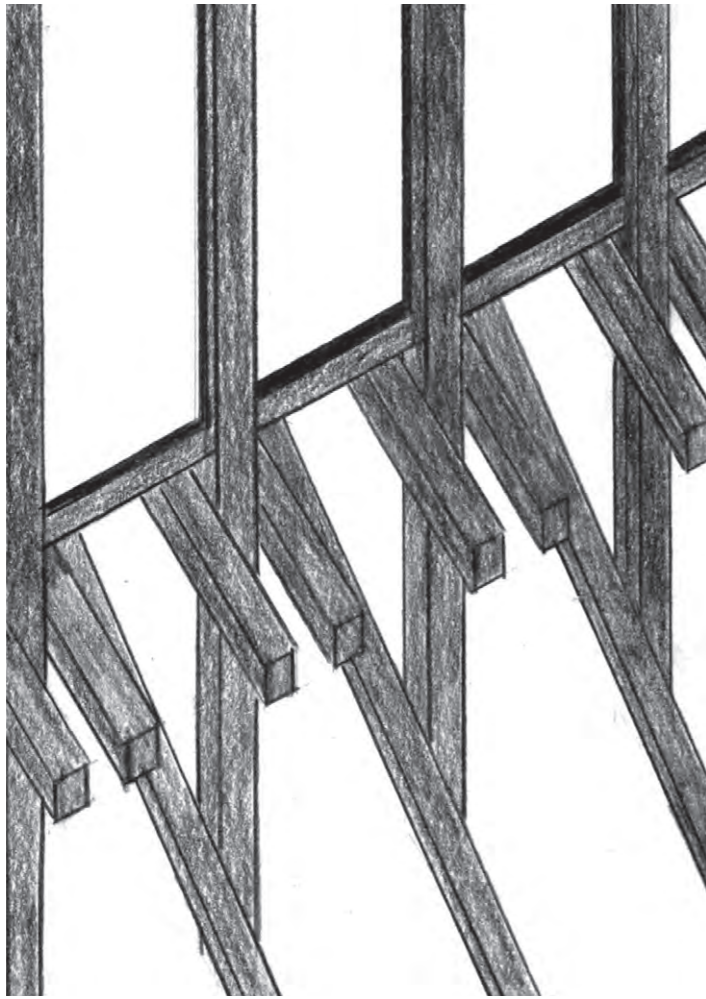



ACT FIVE

The mattress moves.

Two feet on the floo .

Then up in the bed again.

Nothing.

13:00.

Two pair of feet walk away from the bed.
(The door in the wall opens slowly).

End of Act five.





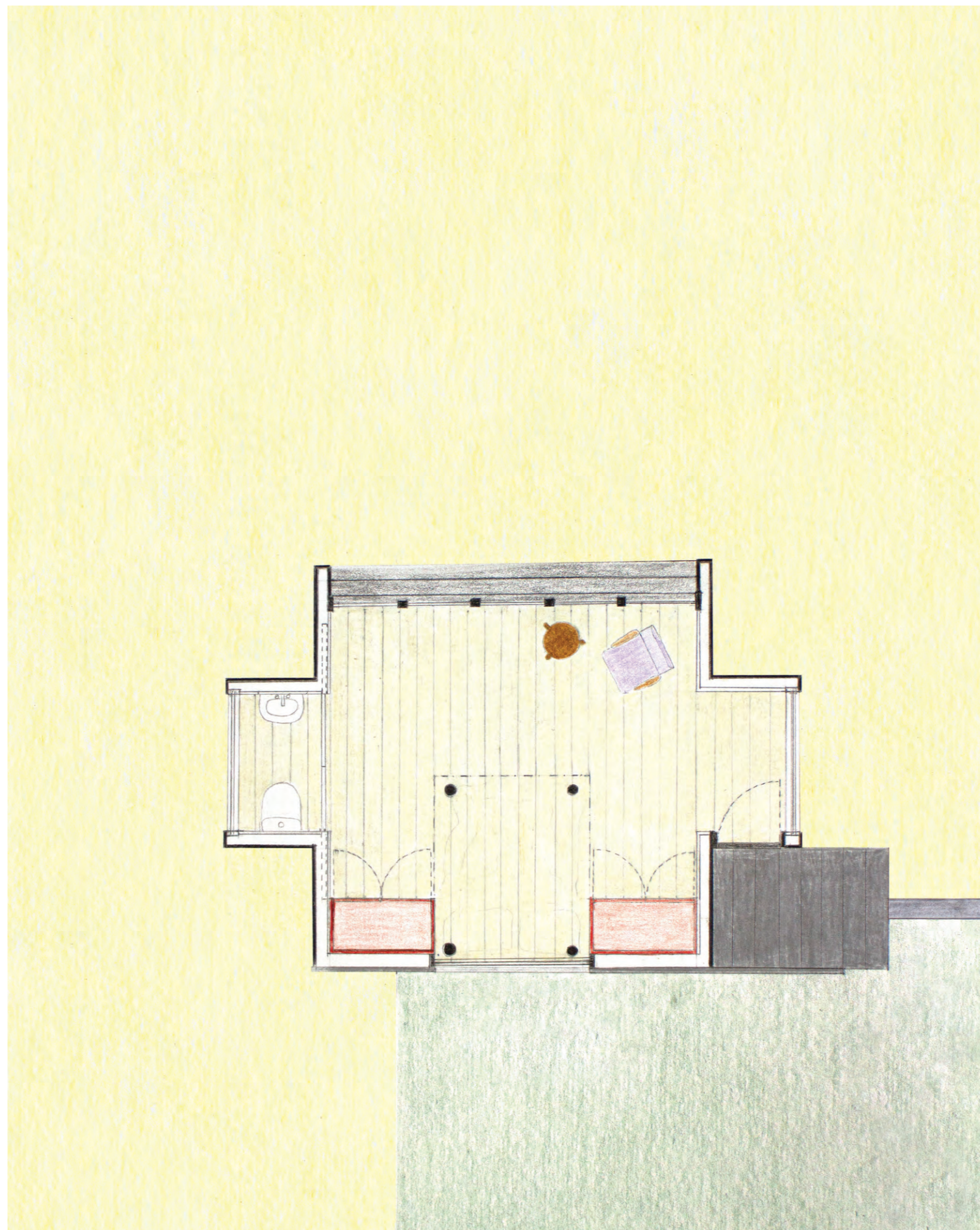

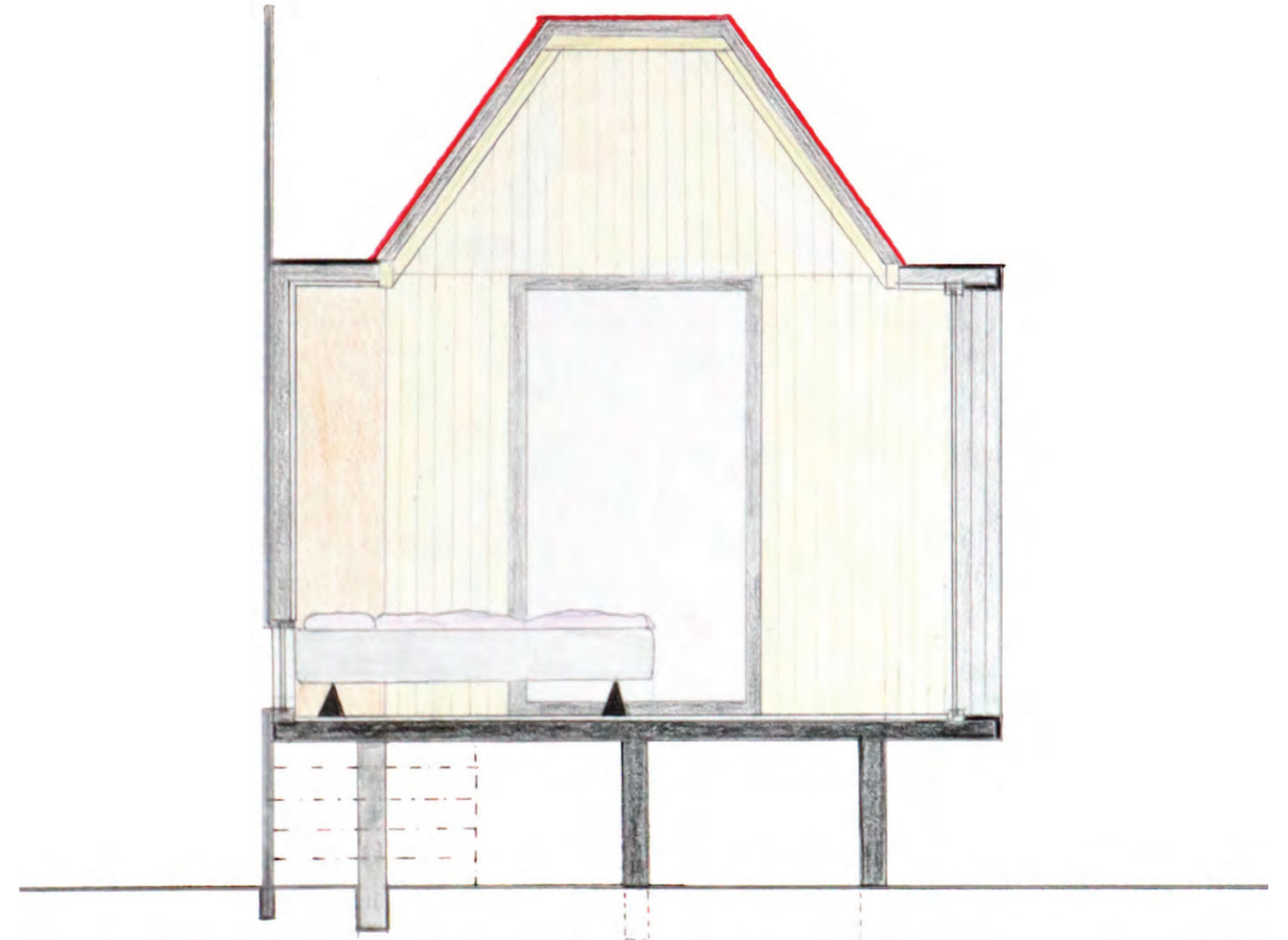
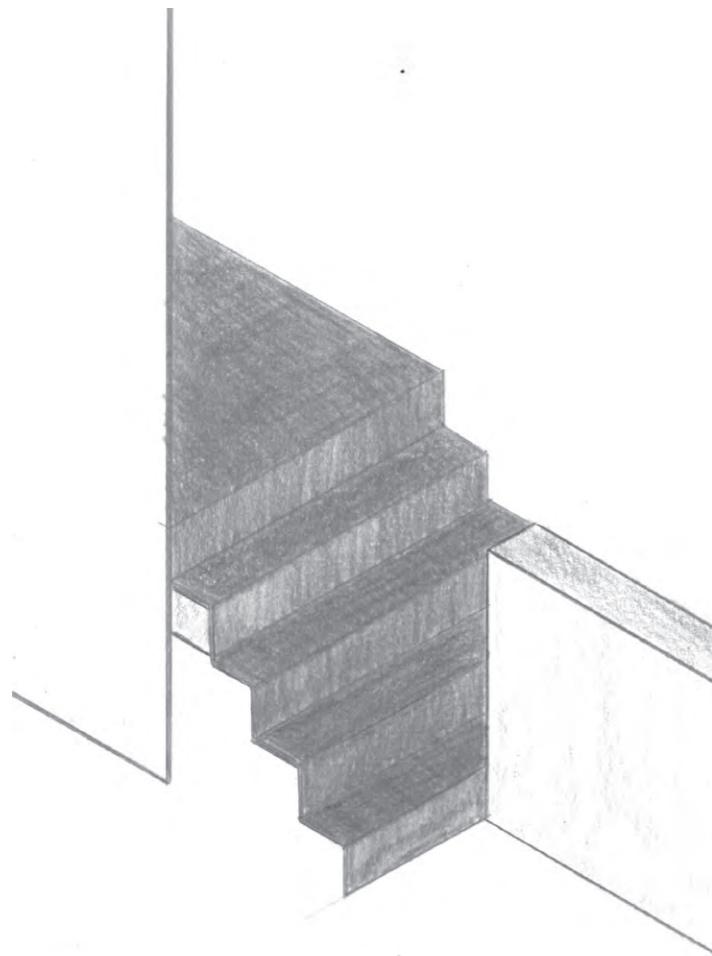

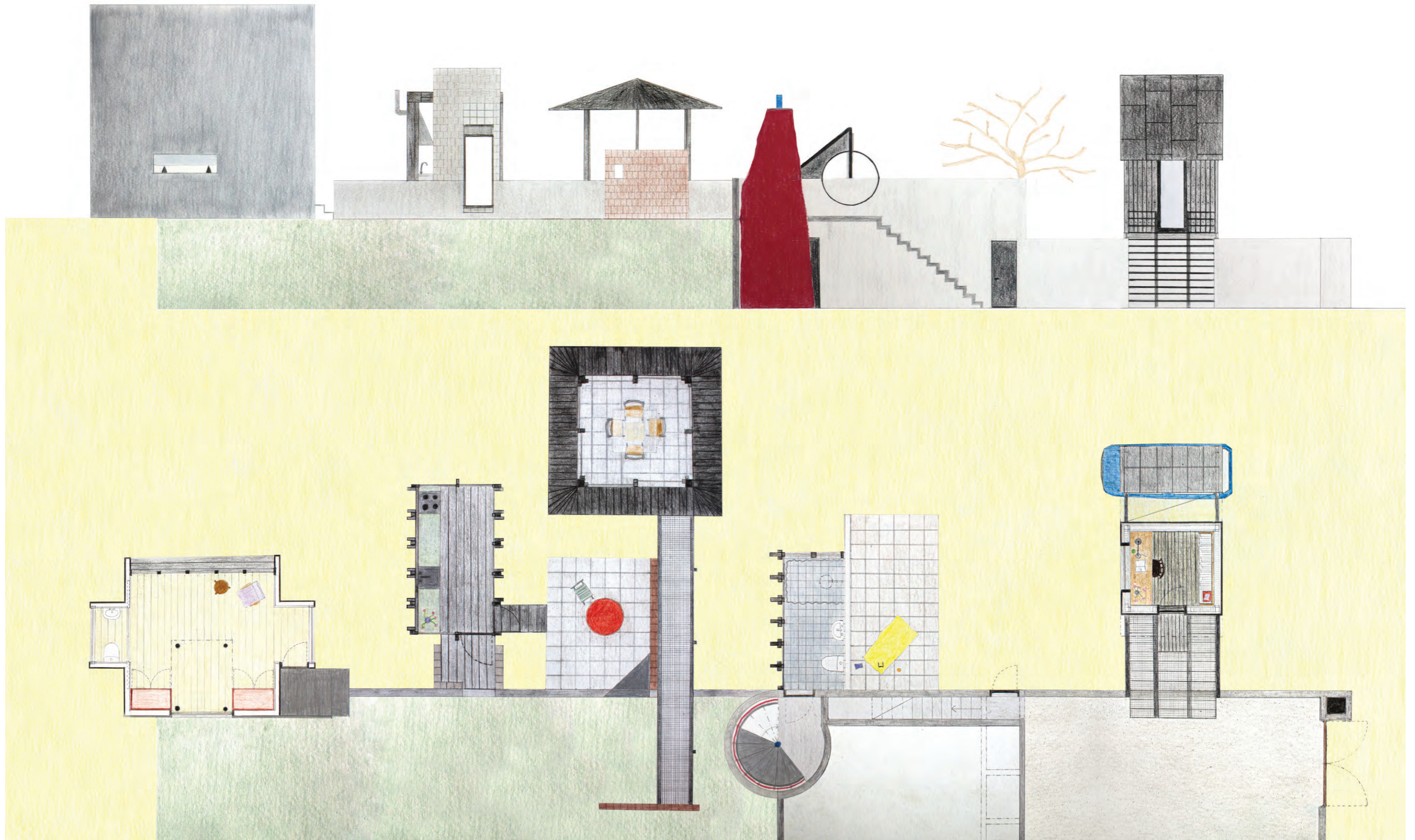



House Ex of In in the context of House for an Art Collector (CH)



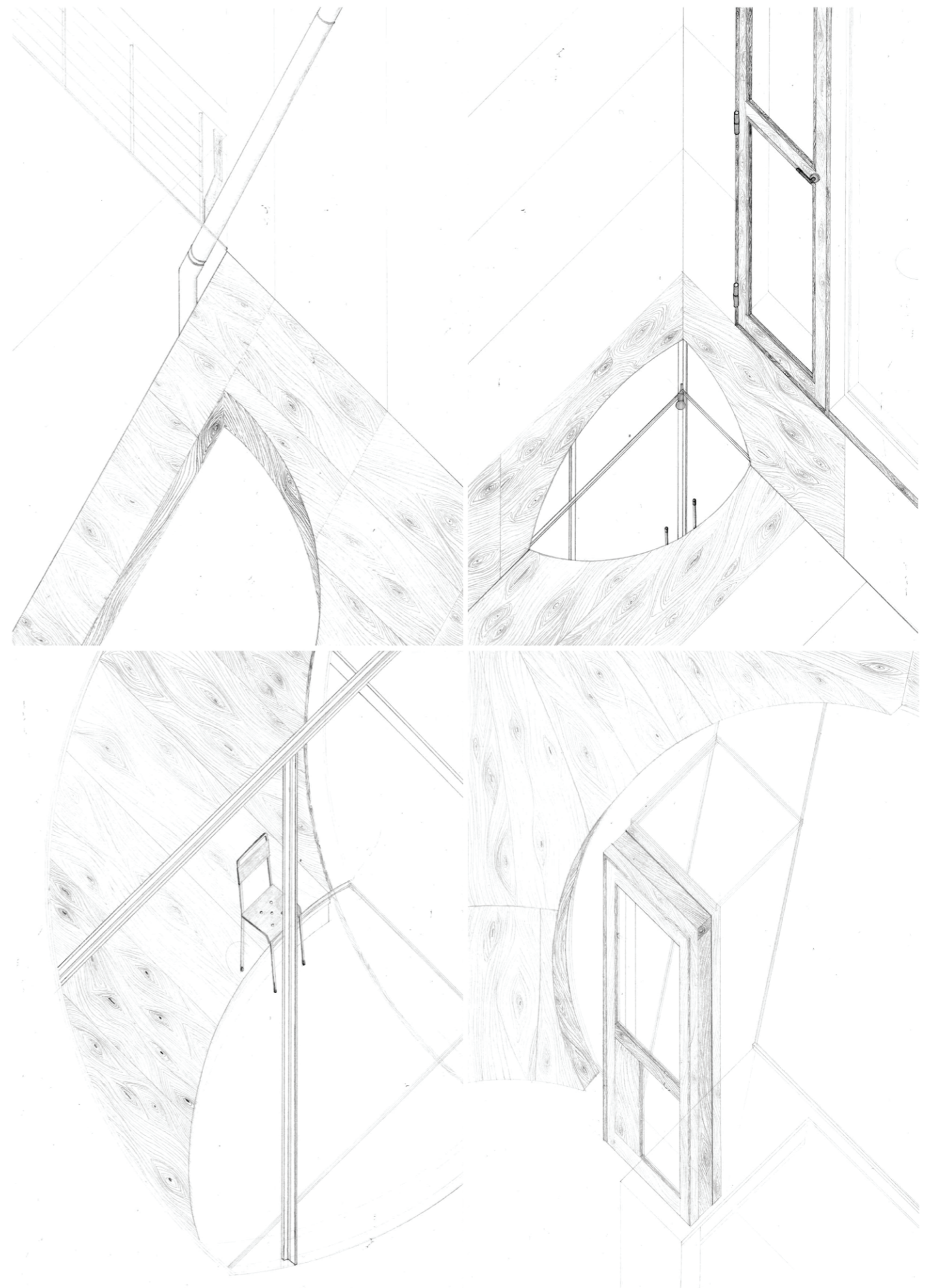
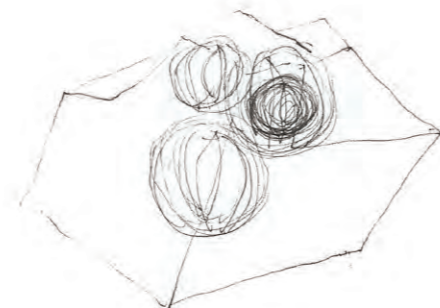
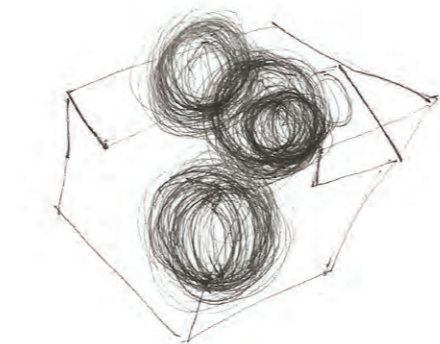

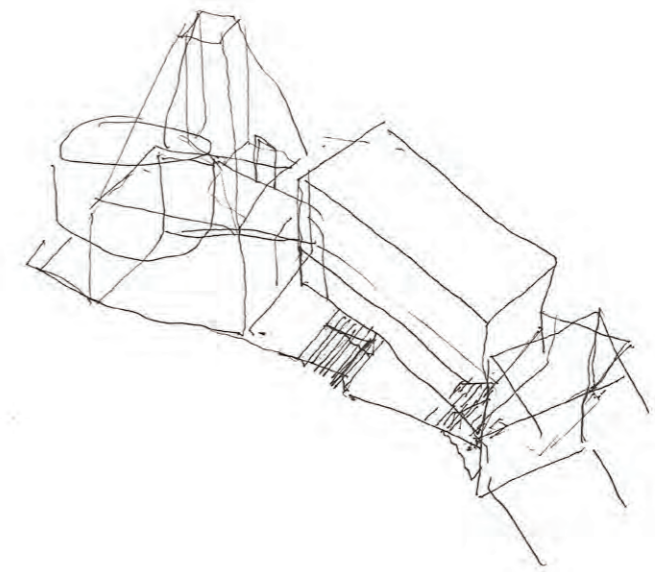
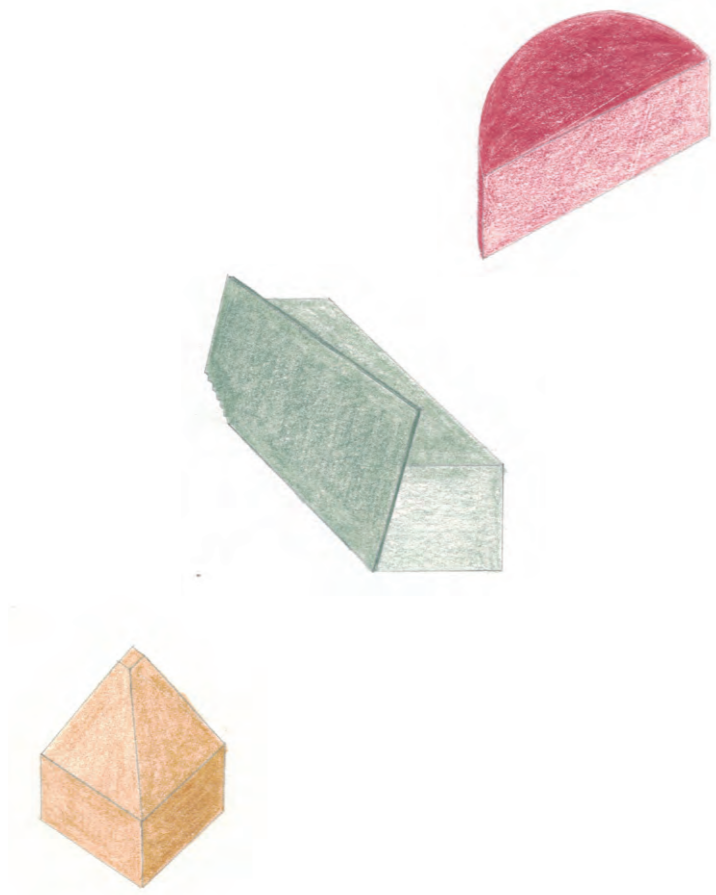

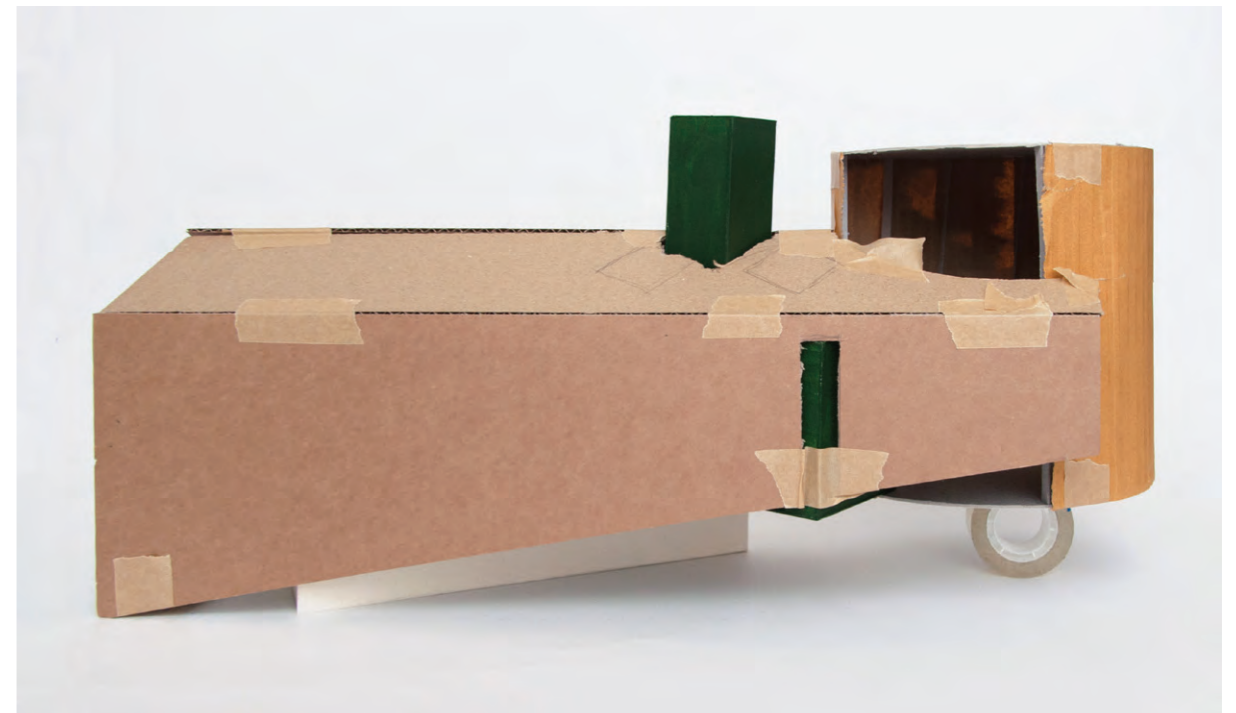
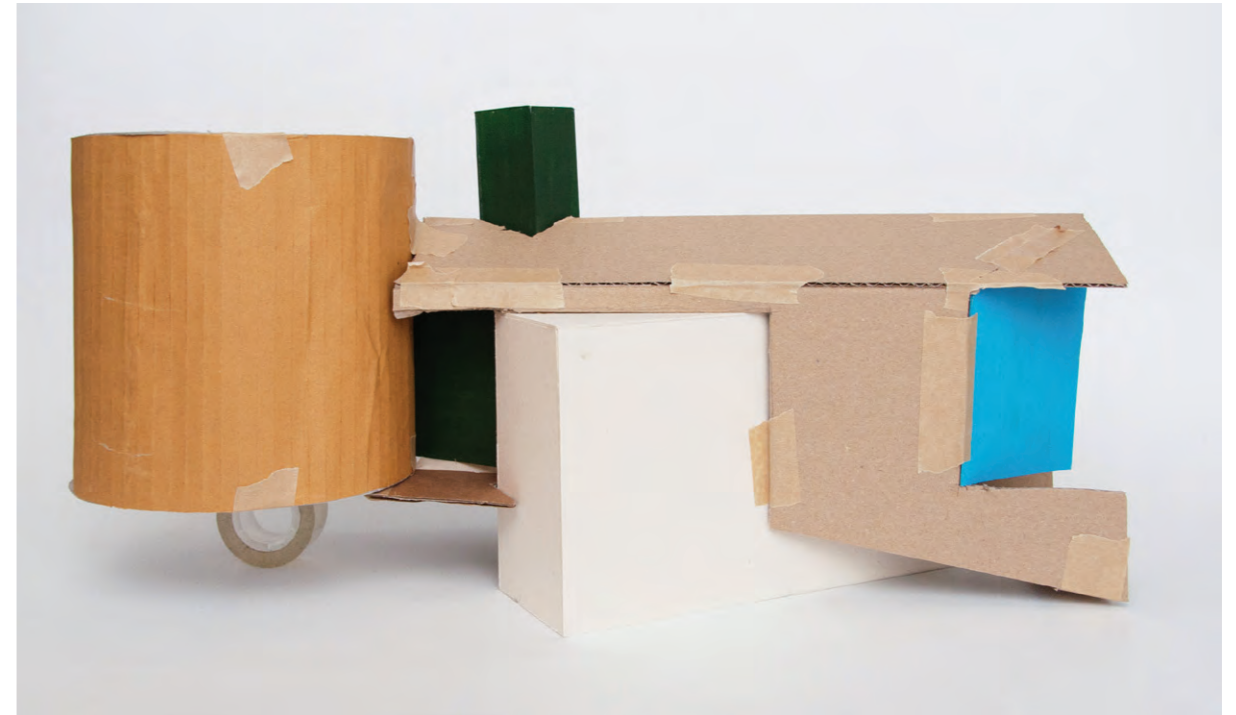
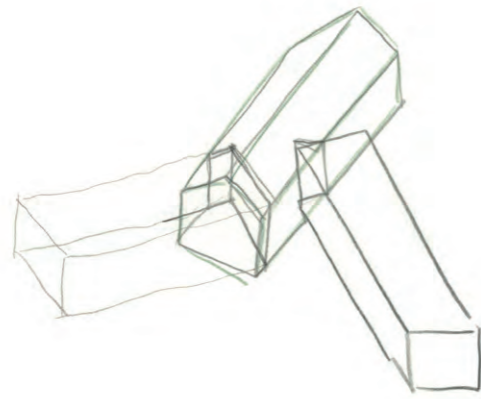

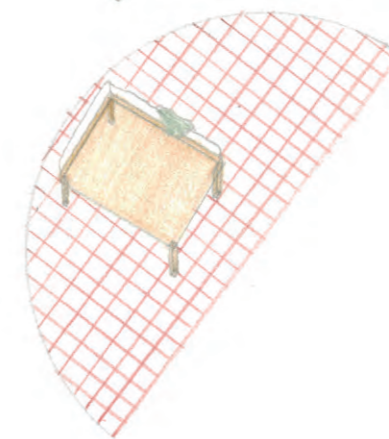
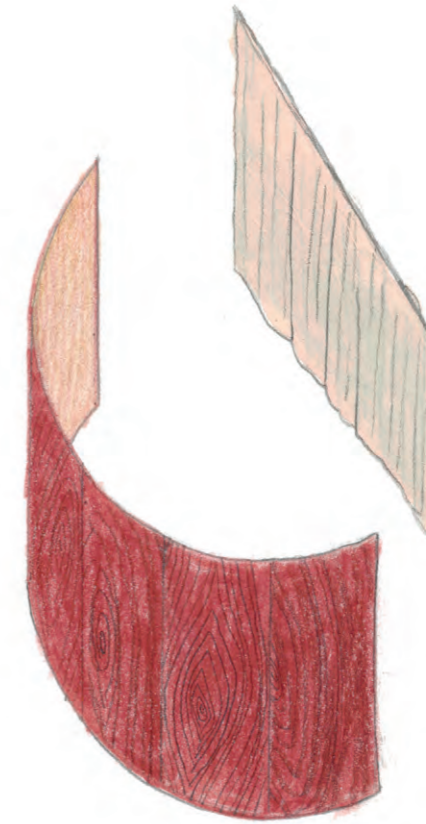
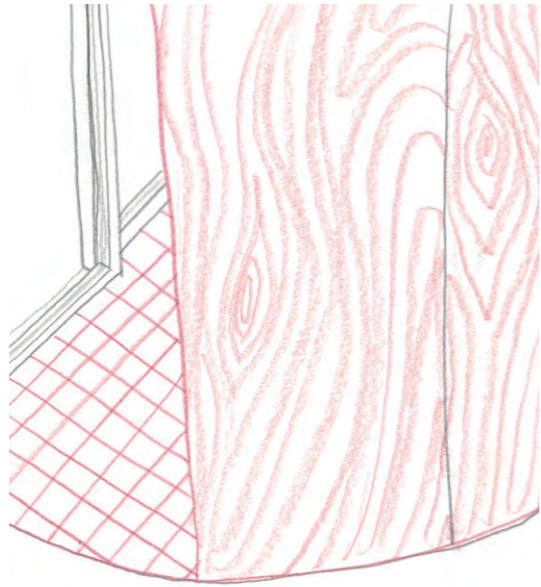

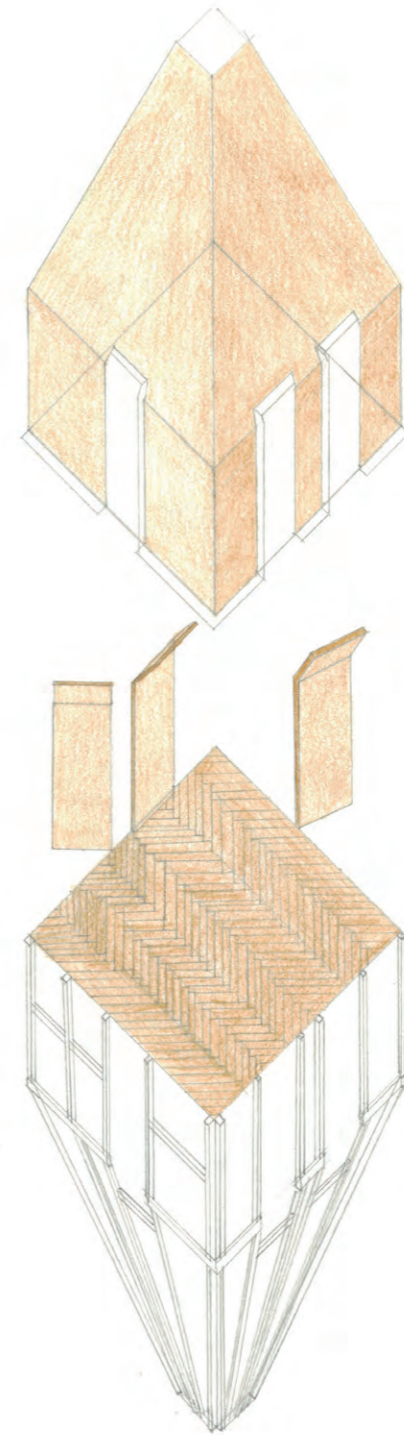
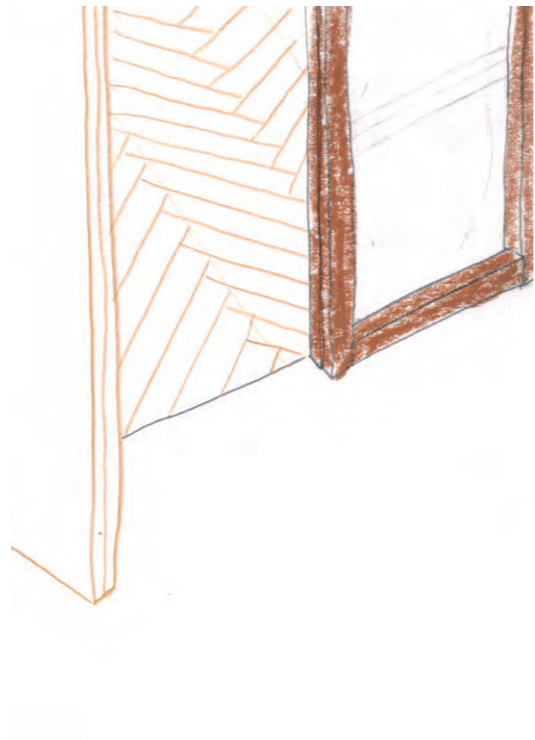

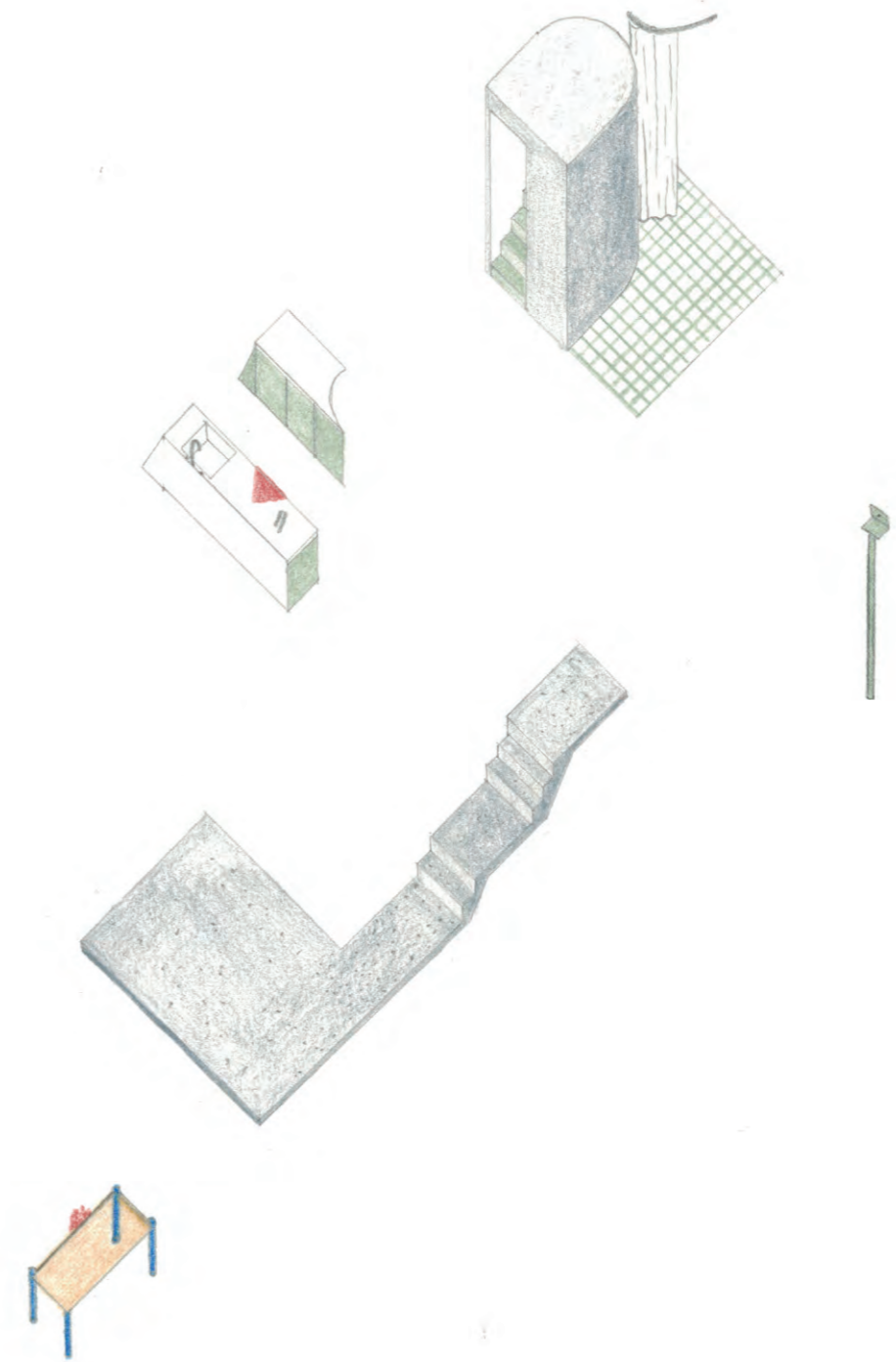
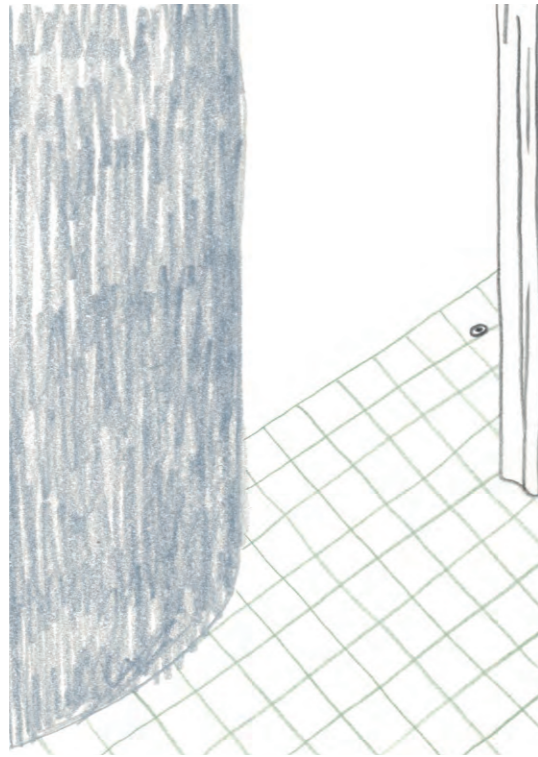

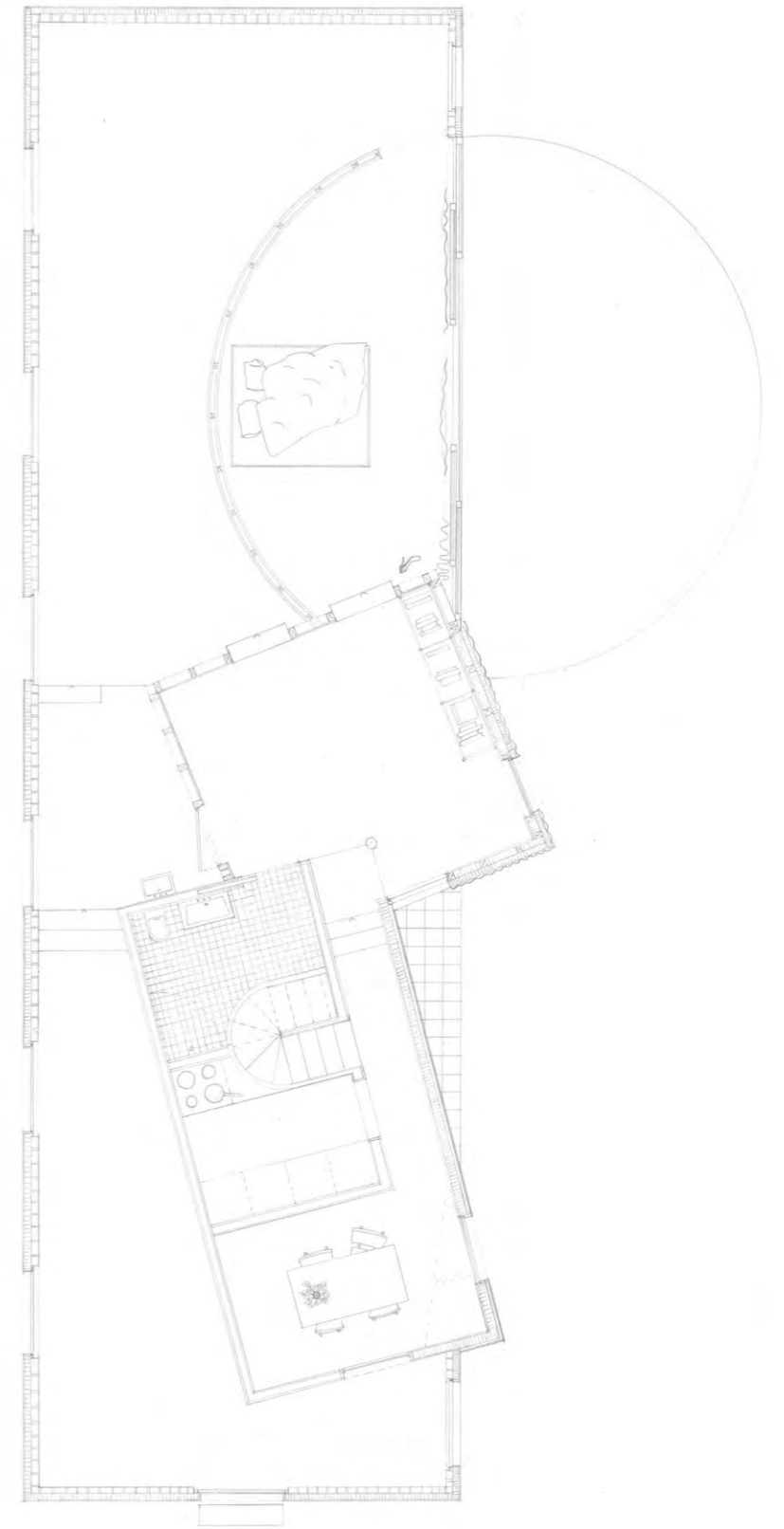
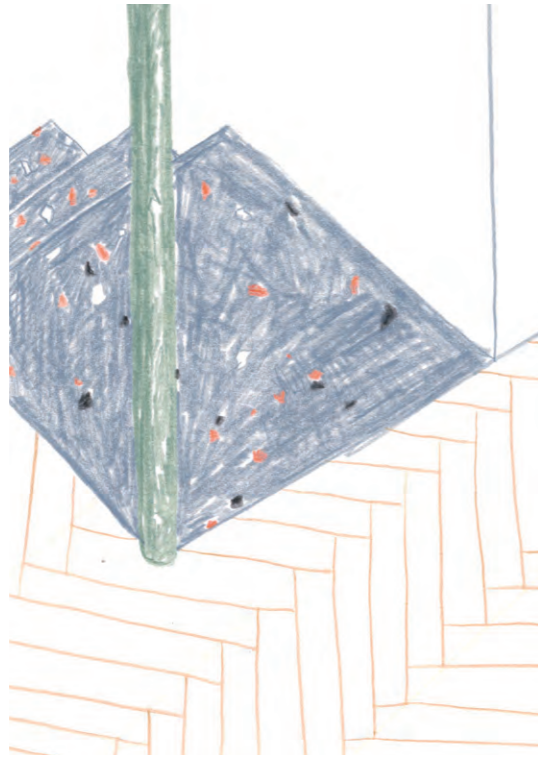

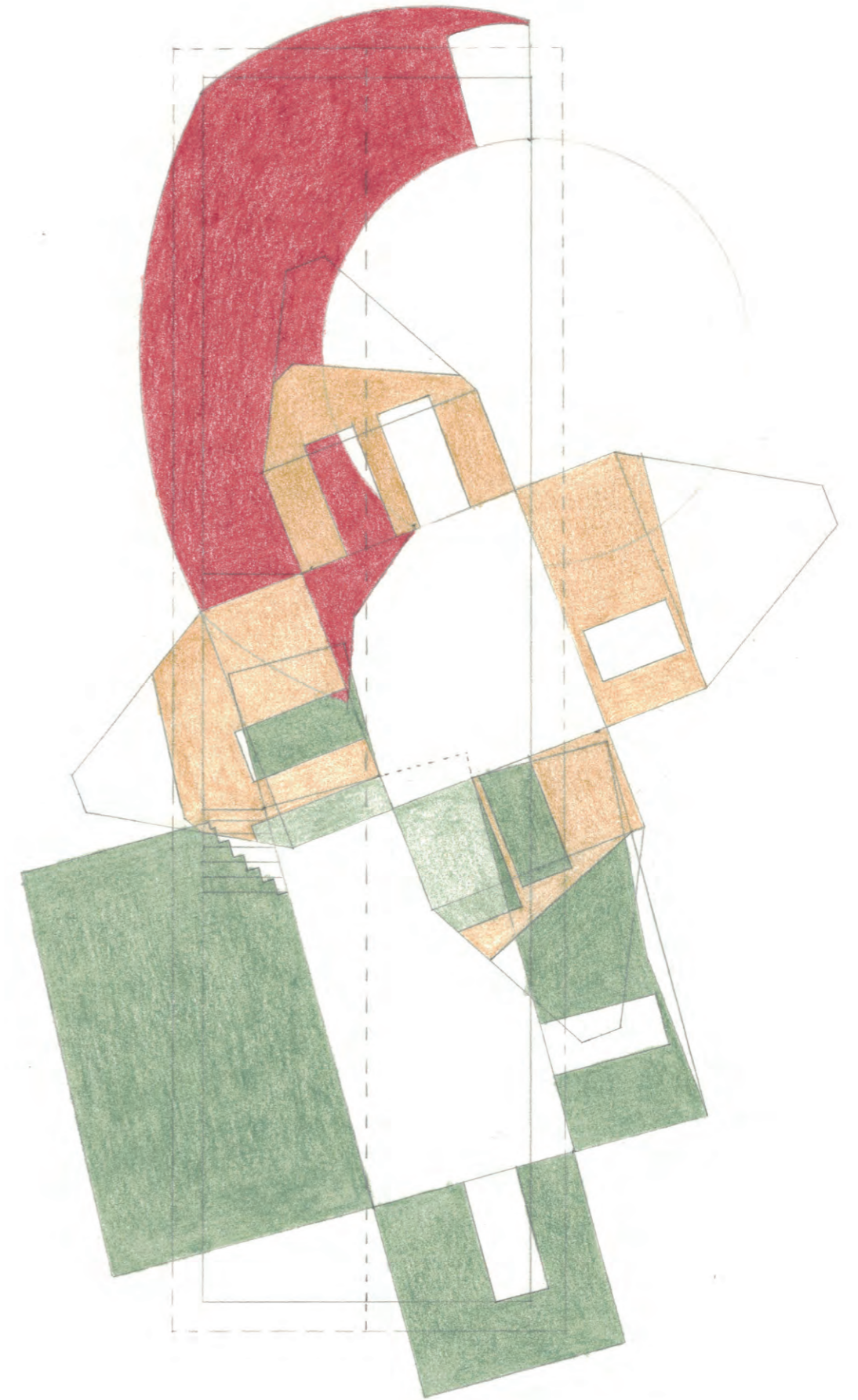
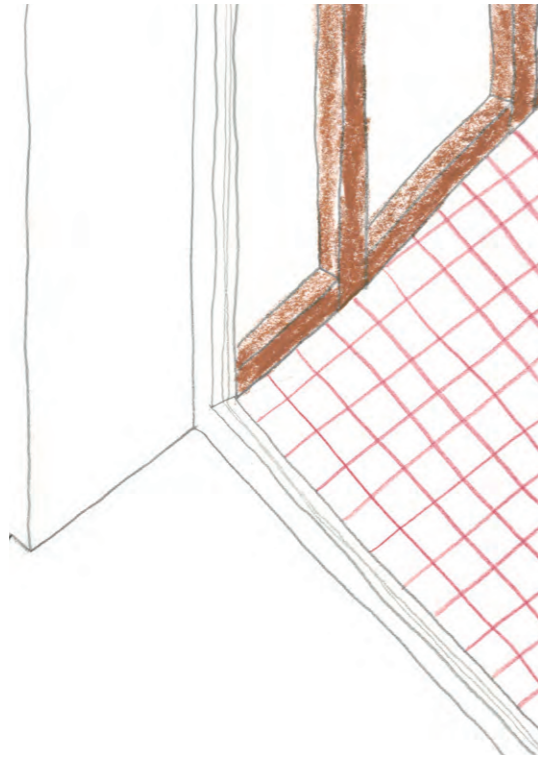

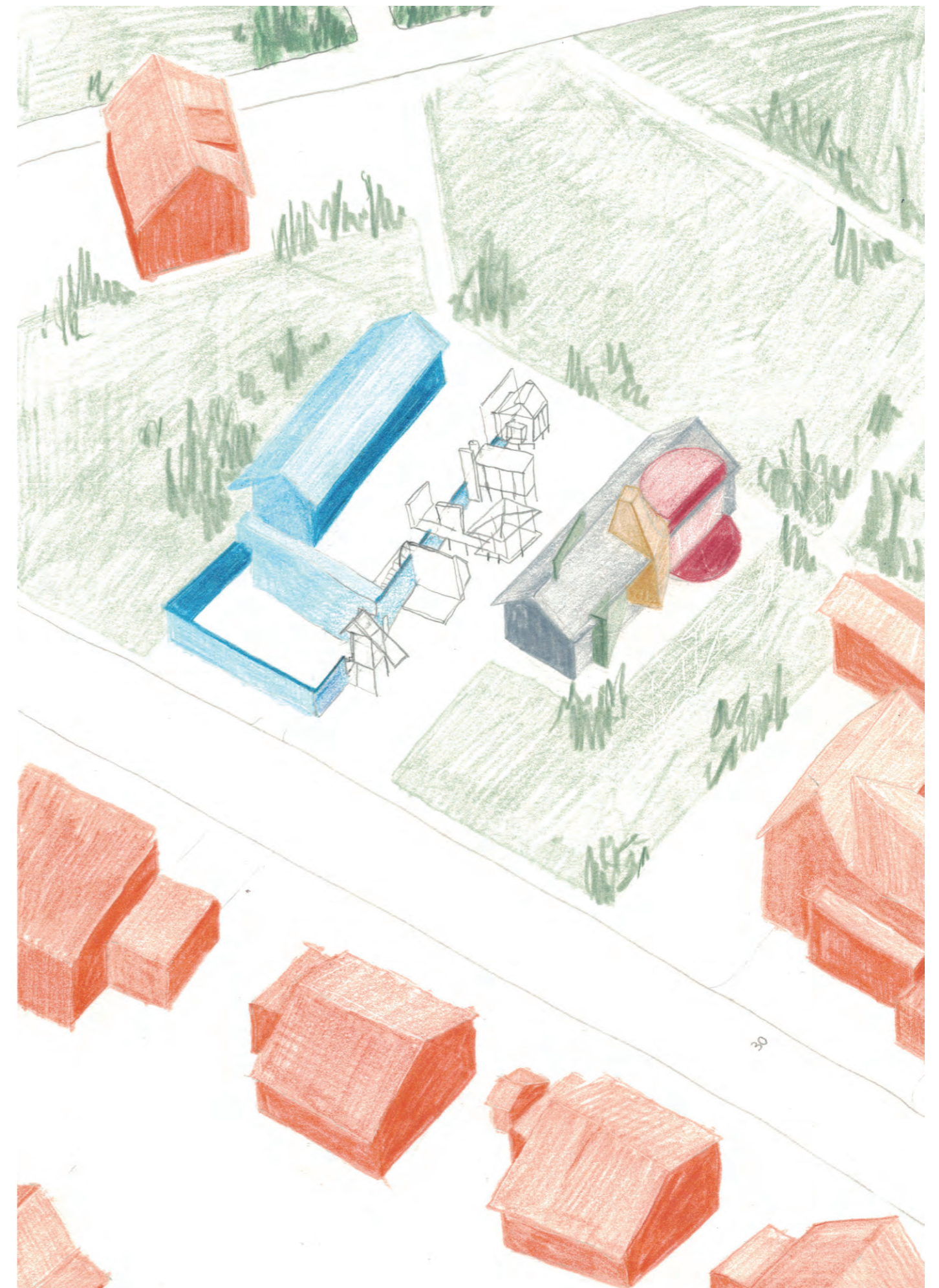

my wardrobe

that shirt i like so much. hanging in the closet right next to my bed, i only take it out for special occasions. i ironed it just yesterday.

and that other shirt, blue, i always put it on when i go painting. as soon as i cross the doorstep, i just feel more comfortable in blue.

1 Three volumes inside of a suburban shack, creating two movements, two ways of inhabiting.

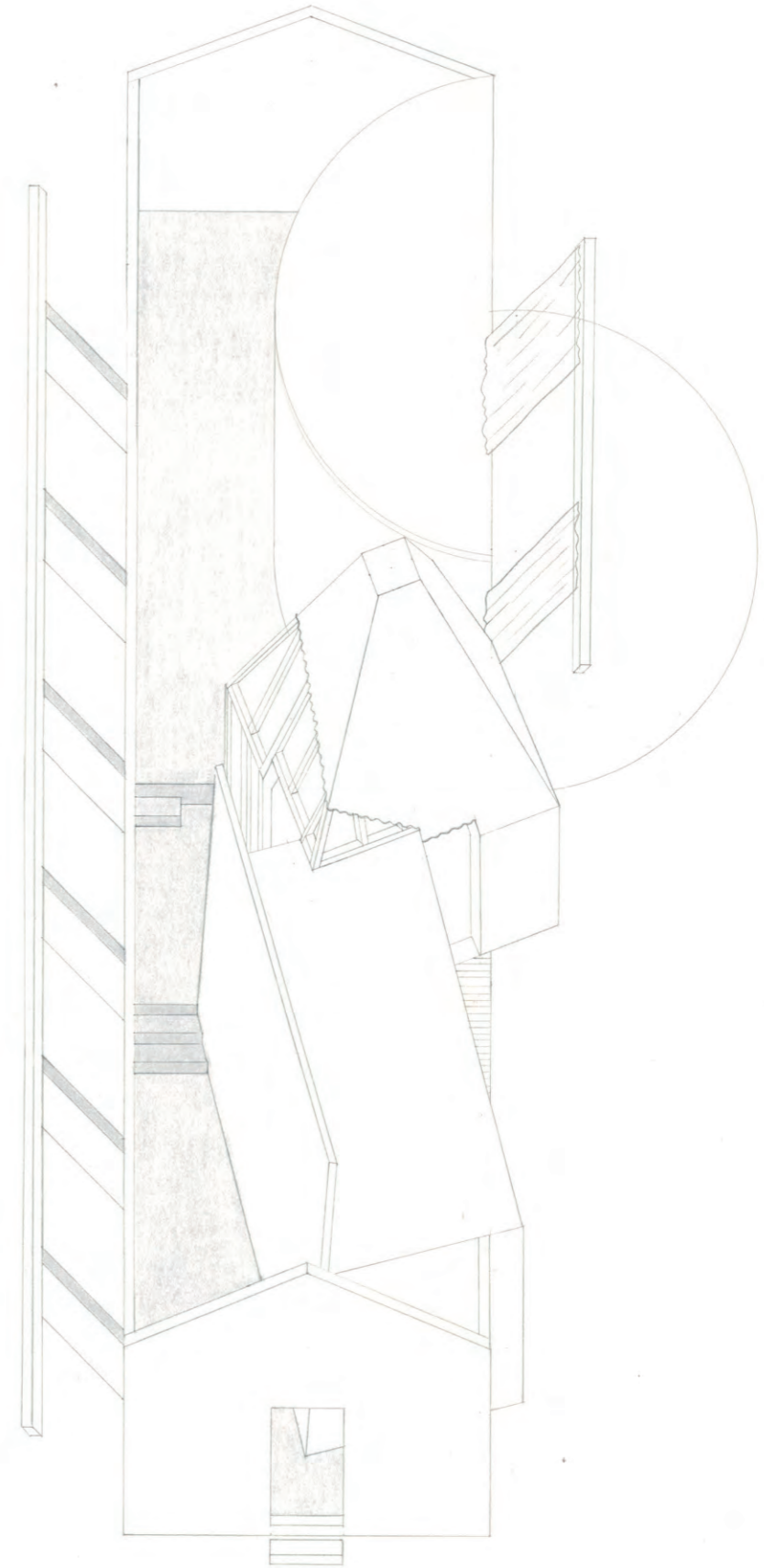

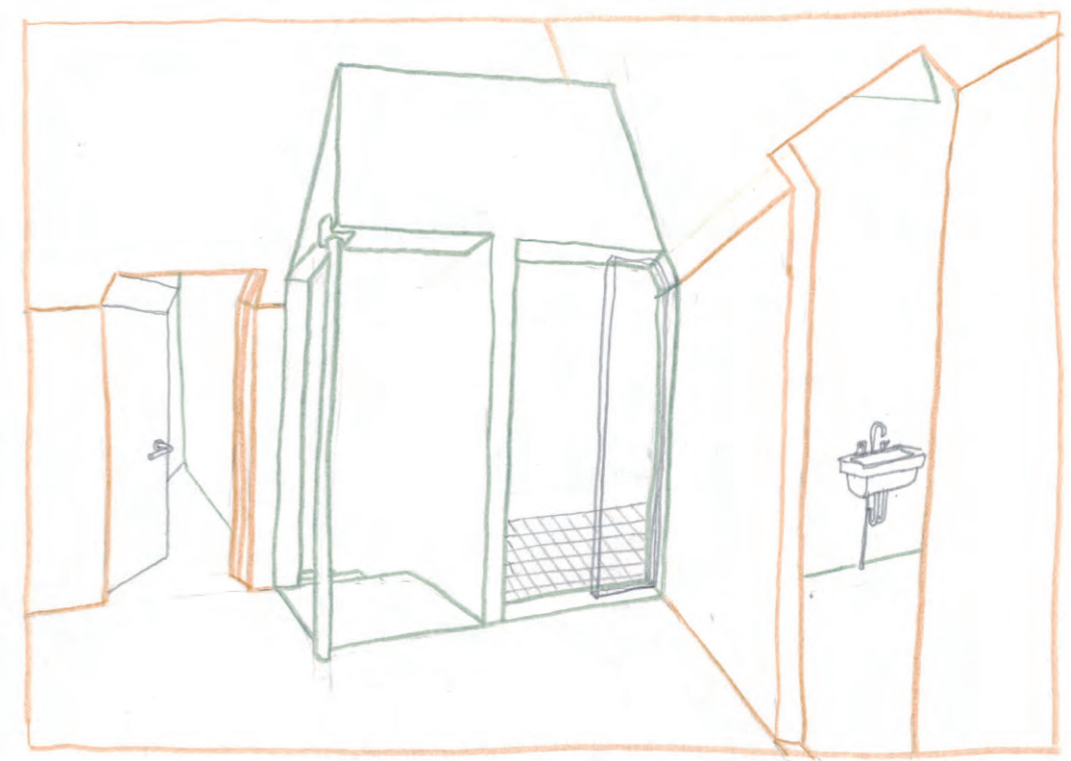
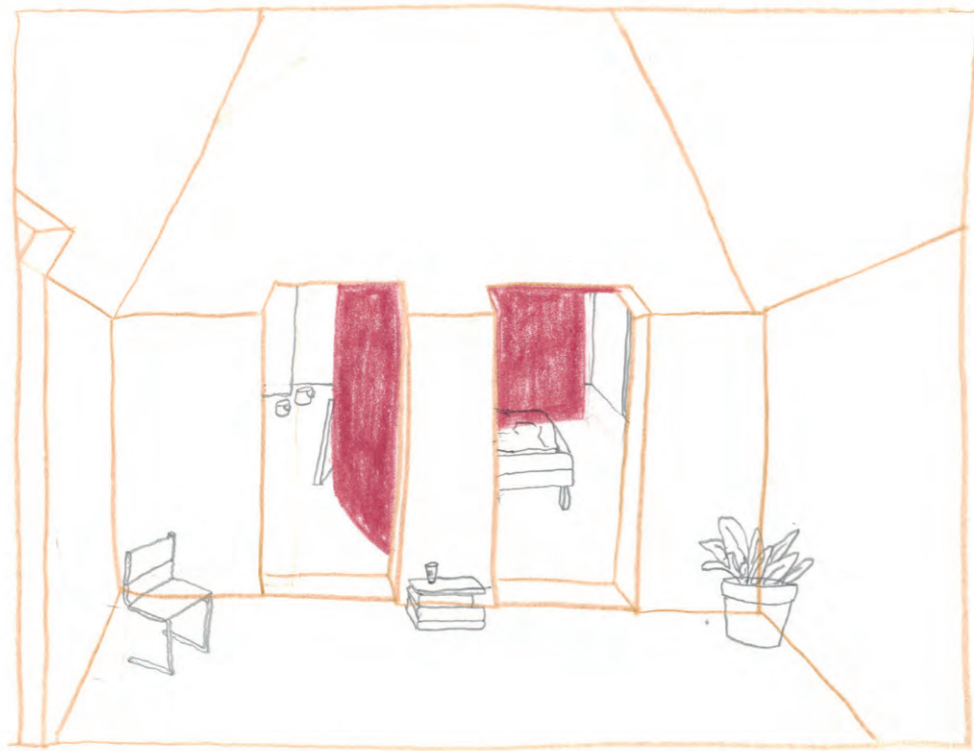

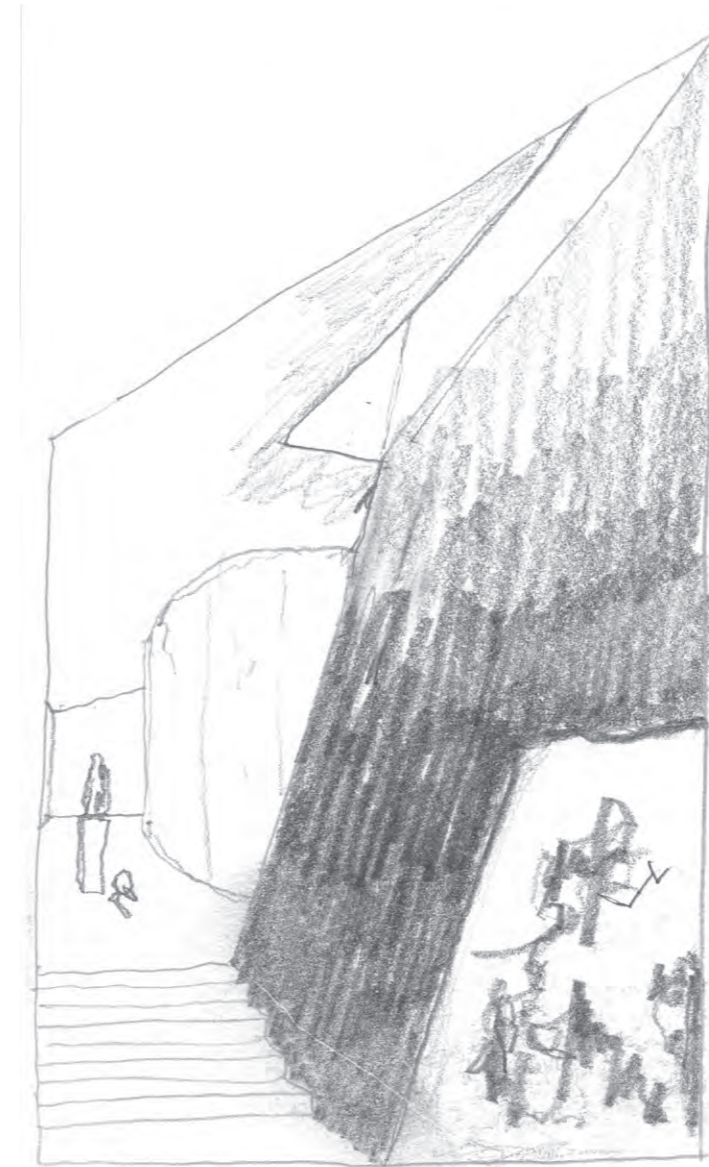
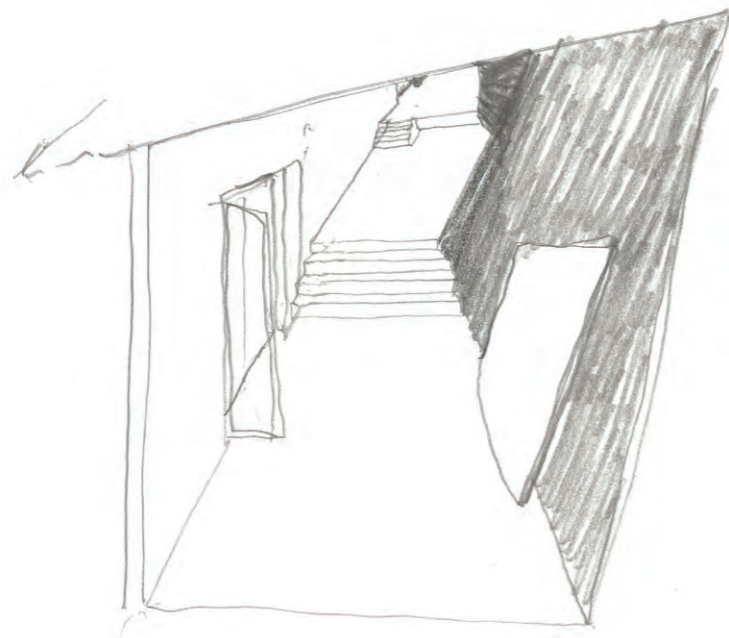
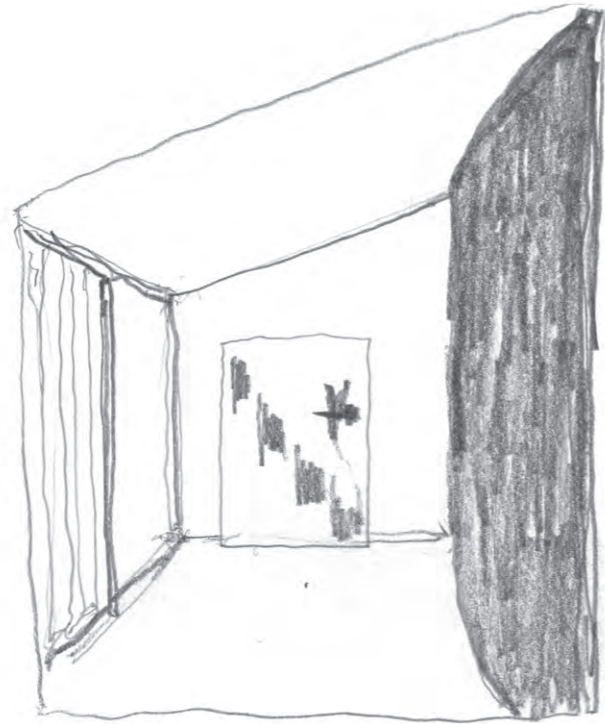

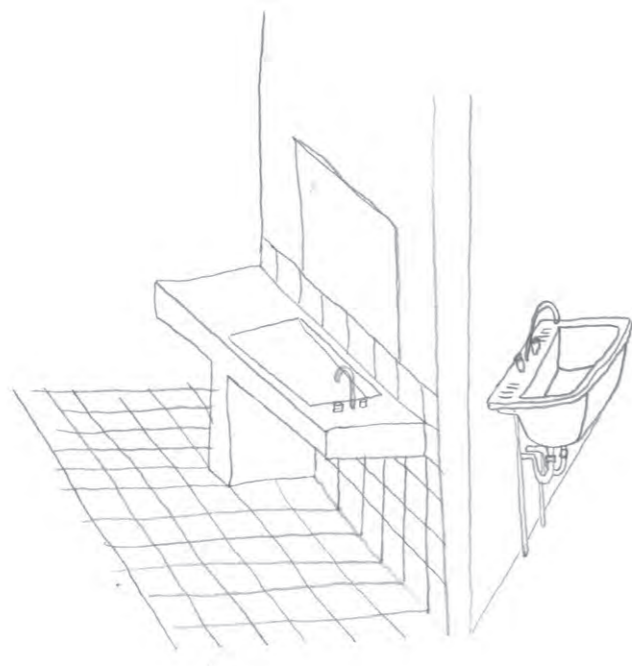

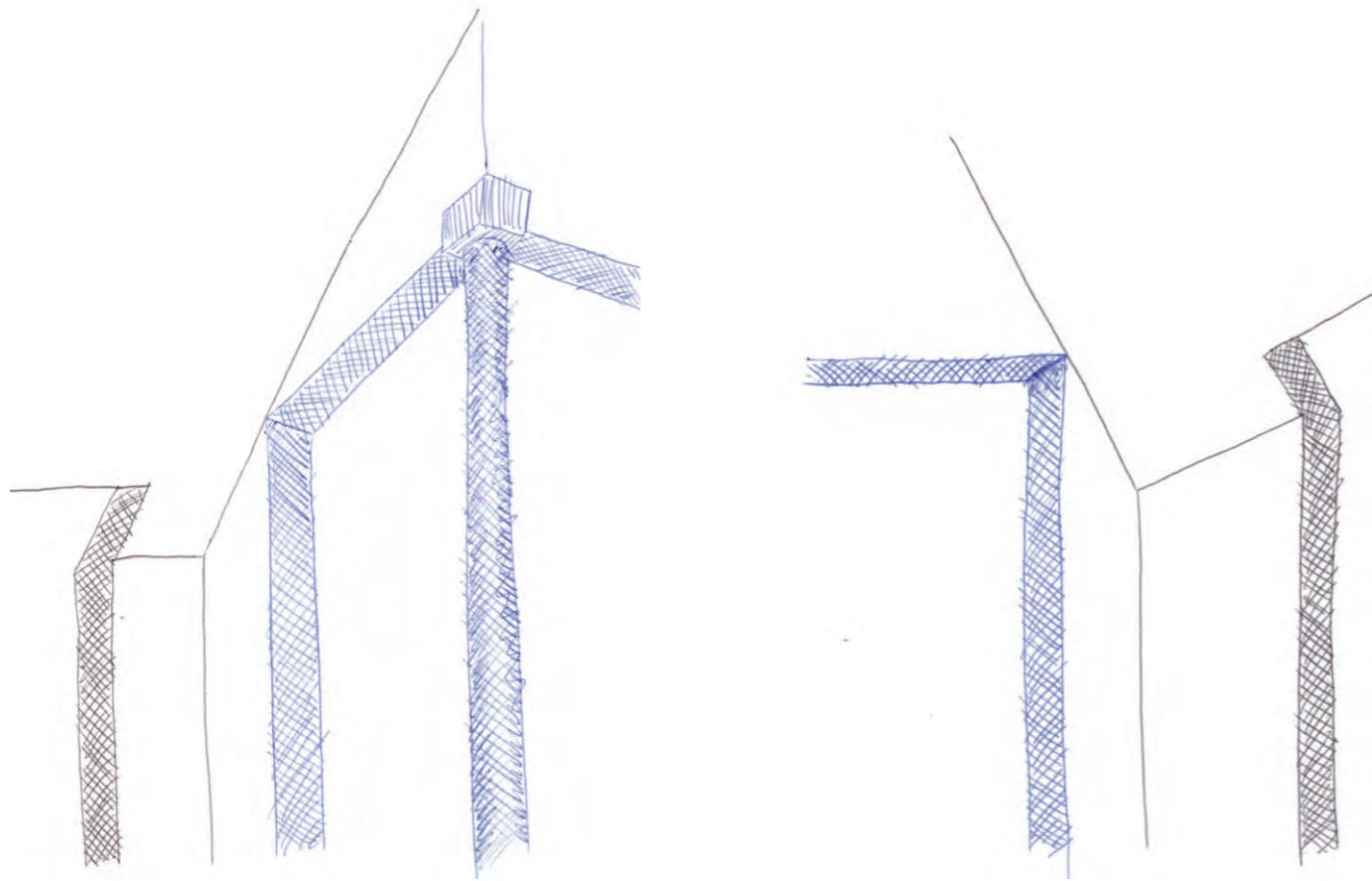



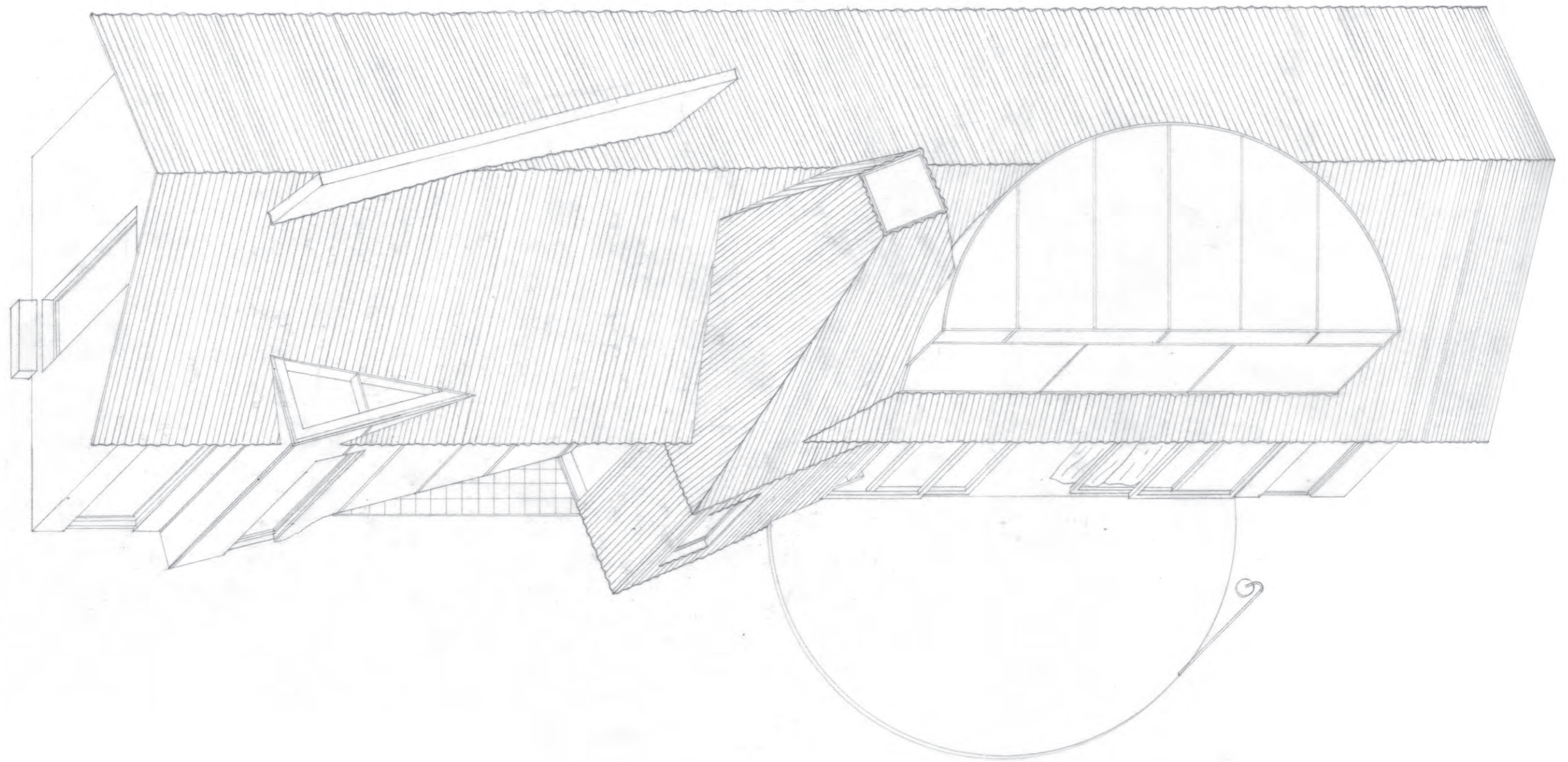

sitting outside, on that small terrace, a cup of hot coffee, the steam rising into the cold winter air.

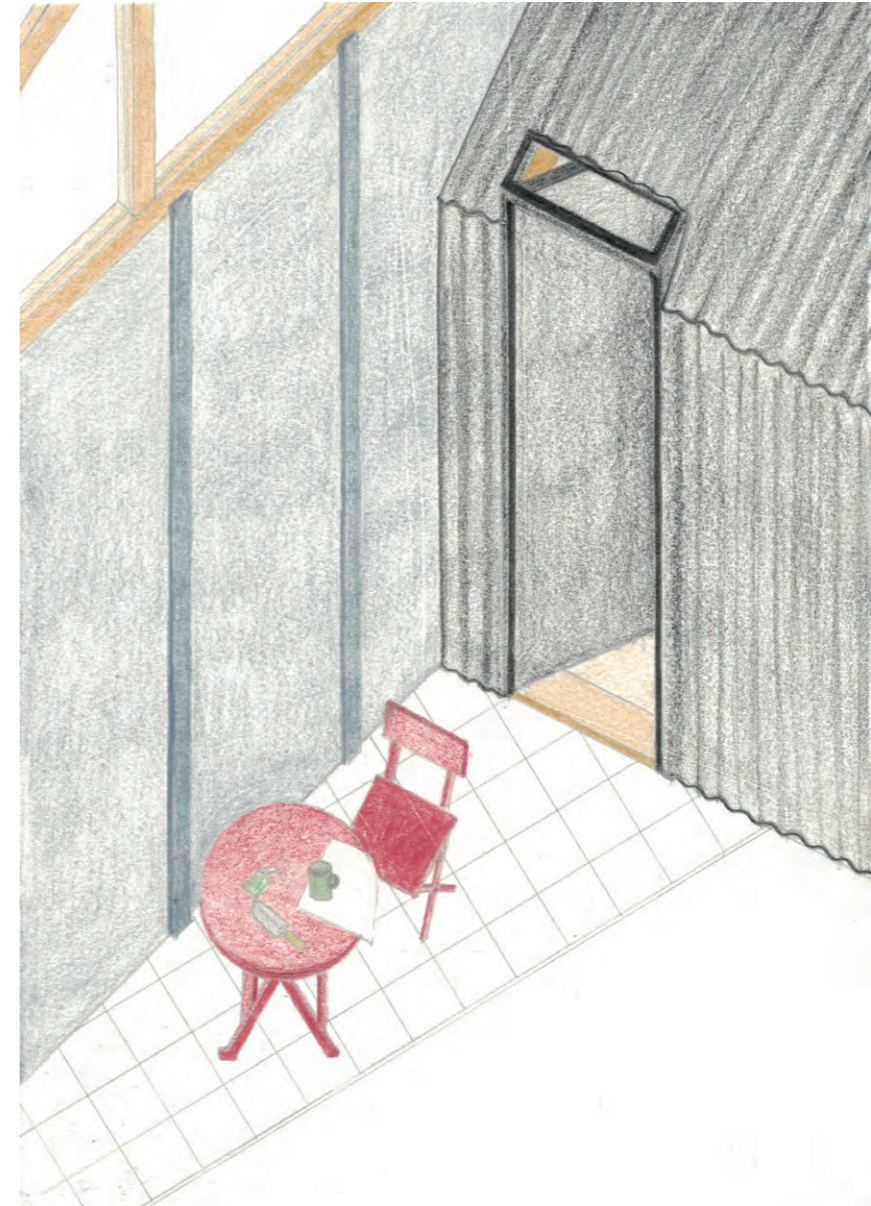

that railing up there in the storage space, must have left it there.

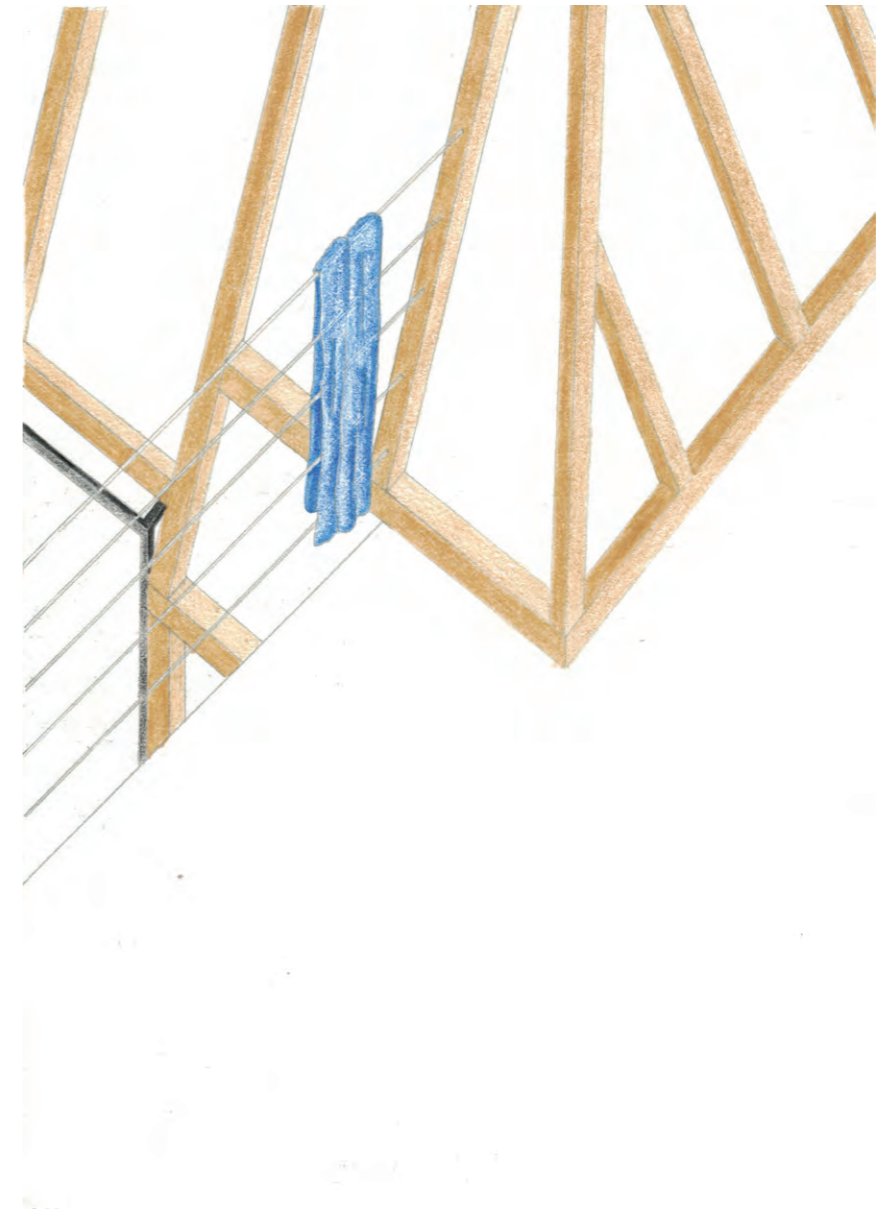

and when you then meet someone,
invite them for a glass of wine over
to your place. the curtains still open,
maybe you just don't care then.

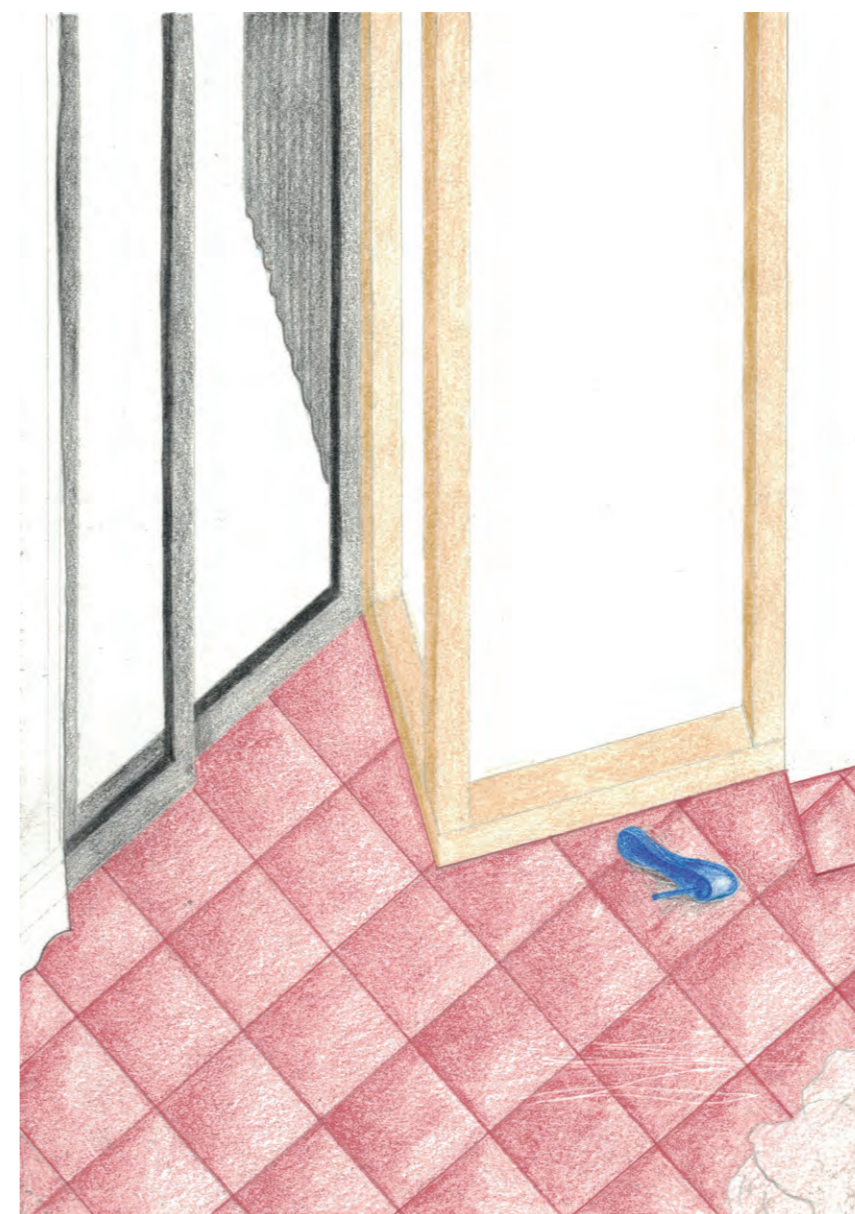

after a week of not painting, finally
having the brush in your hands again,
what a feeling. then there is someone
at the door.

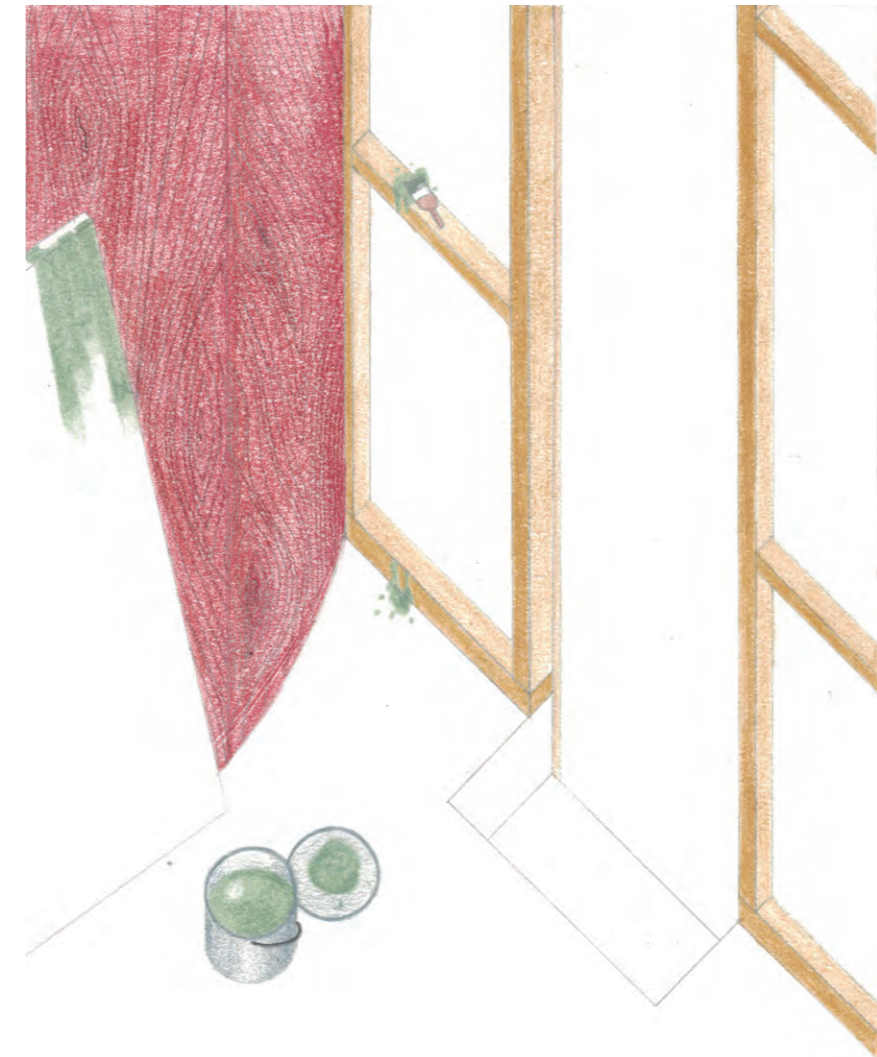

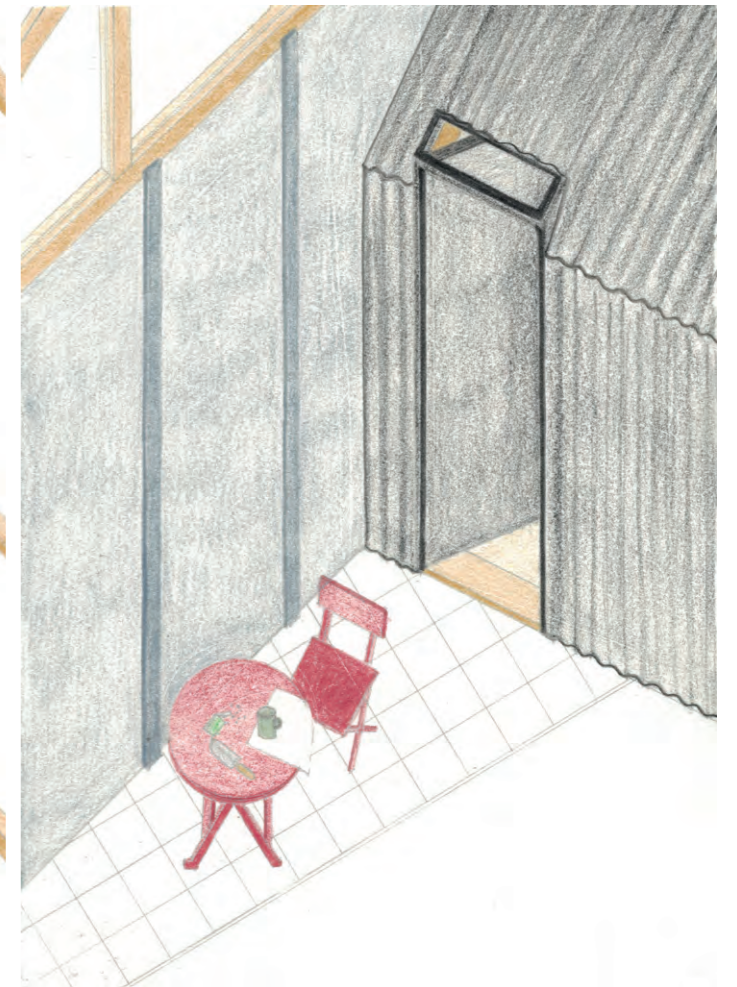
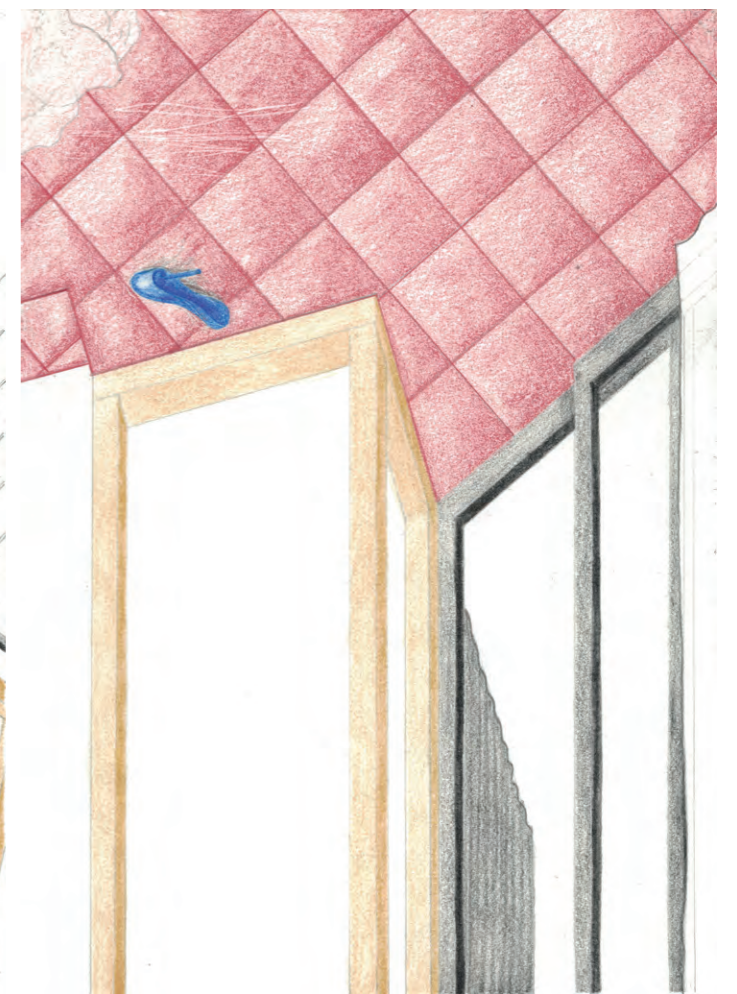
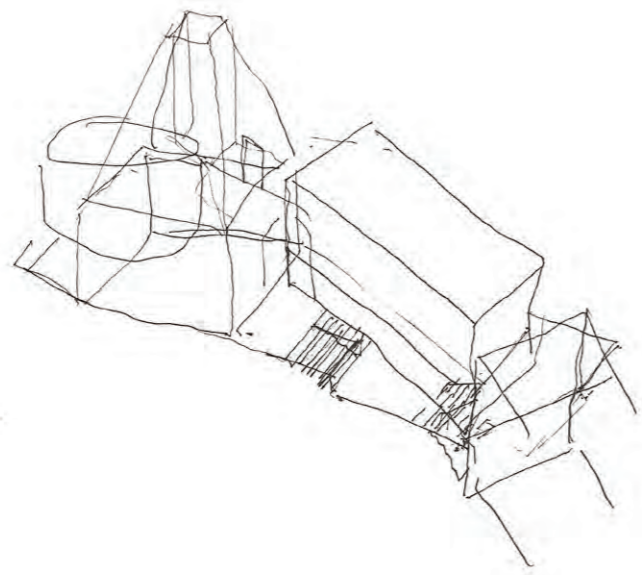

Movement 2

Belgium



Ex of In House in the Context of De Wachter house (BE)

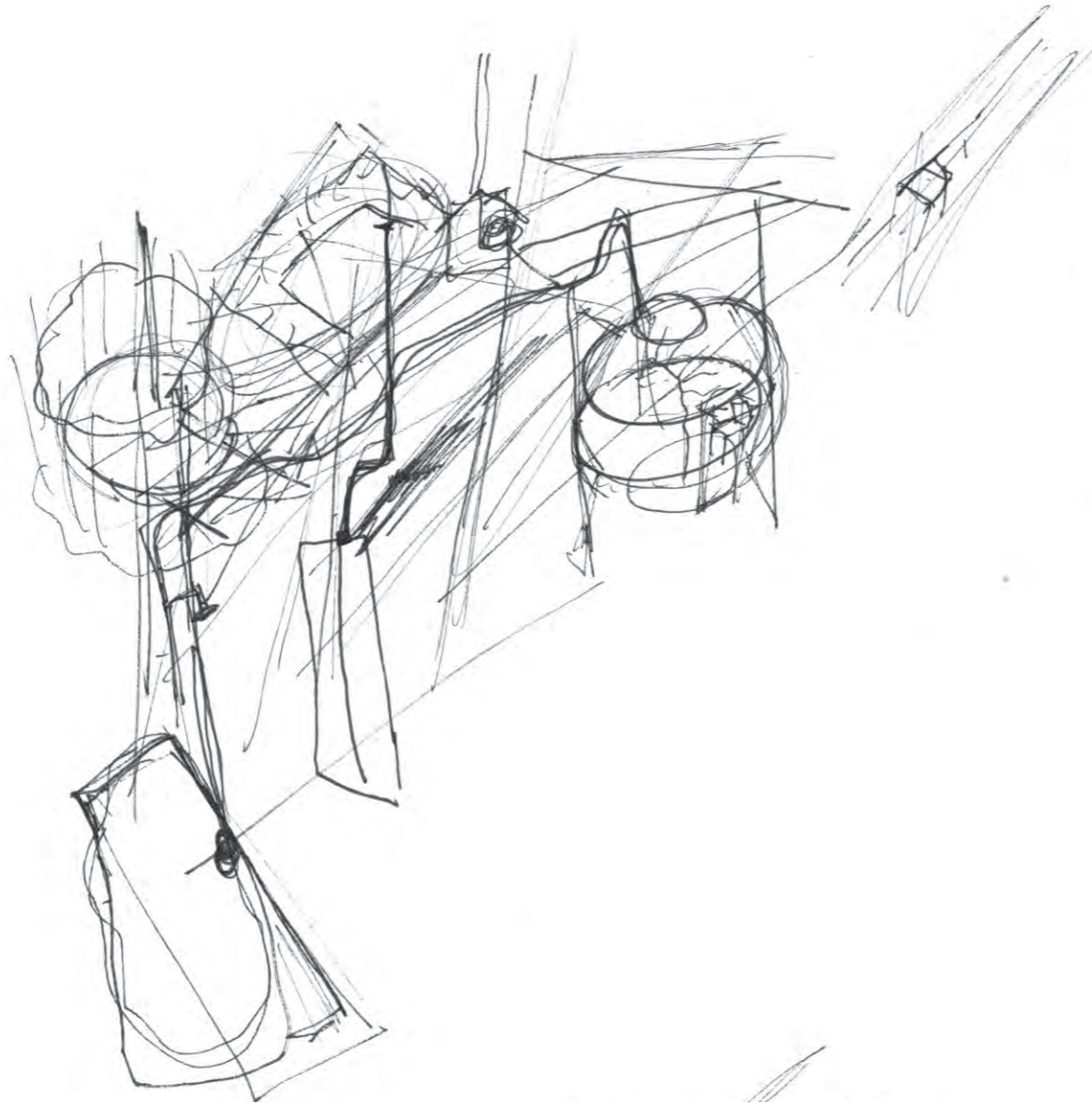



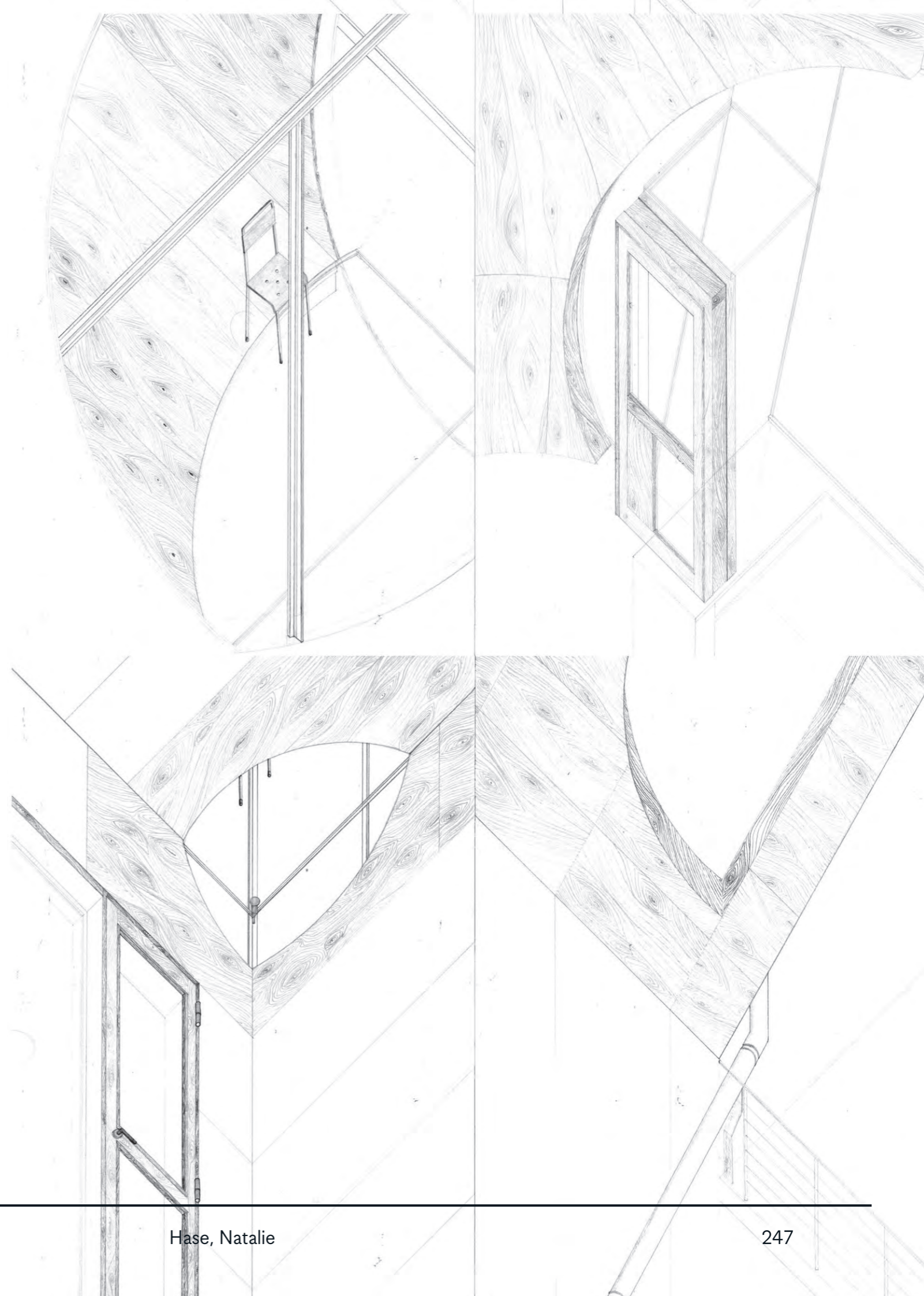
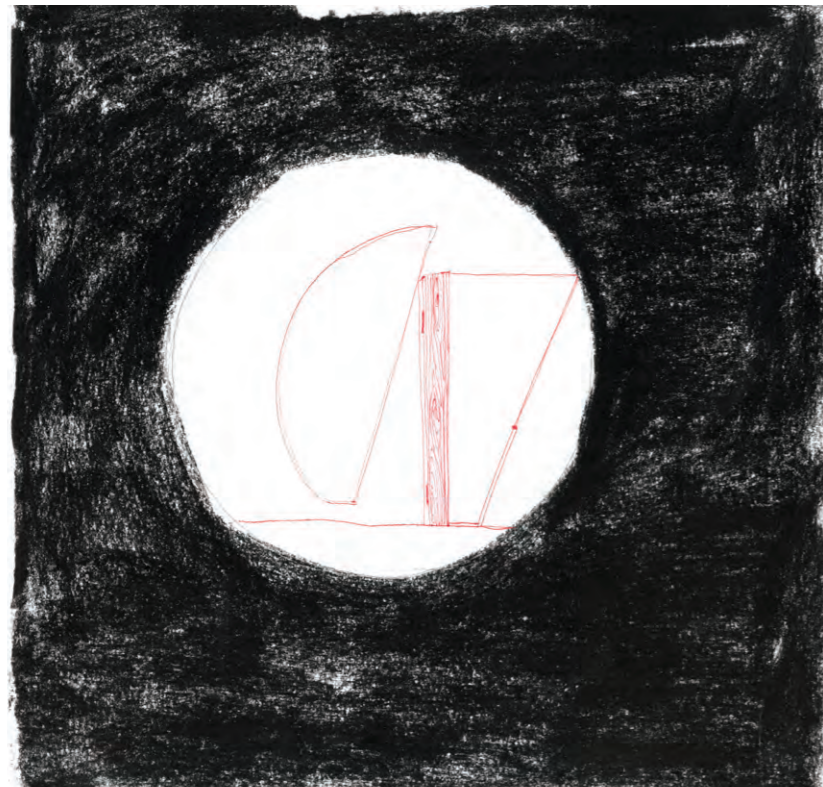

The encounter

“.....It was white with black holes staring at him. The walls were tilted. The inside was round with spheres in perfectly shaped wood. He got scared, wanted to leave. But then he sae something that struck him – there were parts of the house not really fitting. Anomalities in these pe fectly round shapes. Looking like they belonged somewhere else, as if trying to break loose. The Gardner was deeply touched by what he saw. And made a promise to himself, never to forget.....”

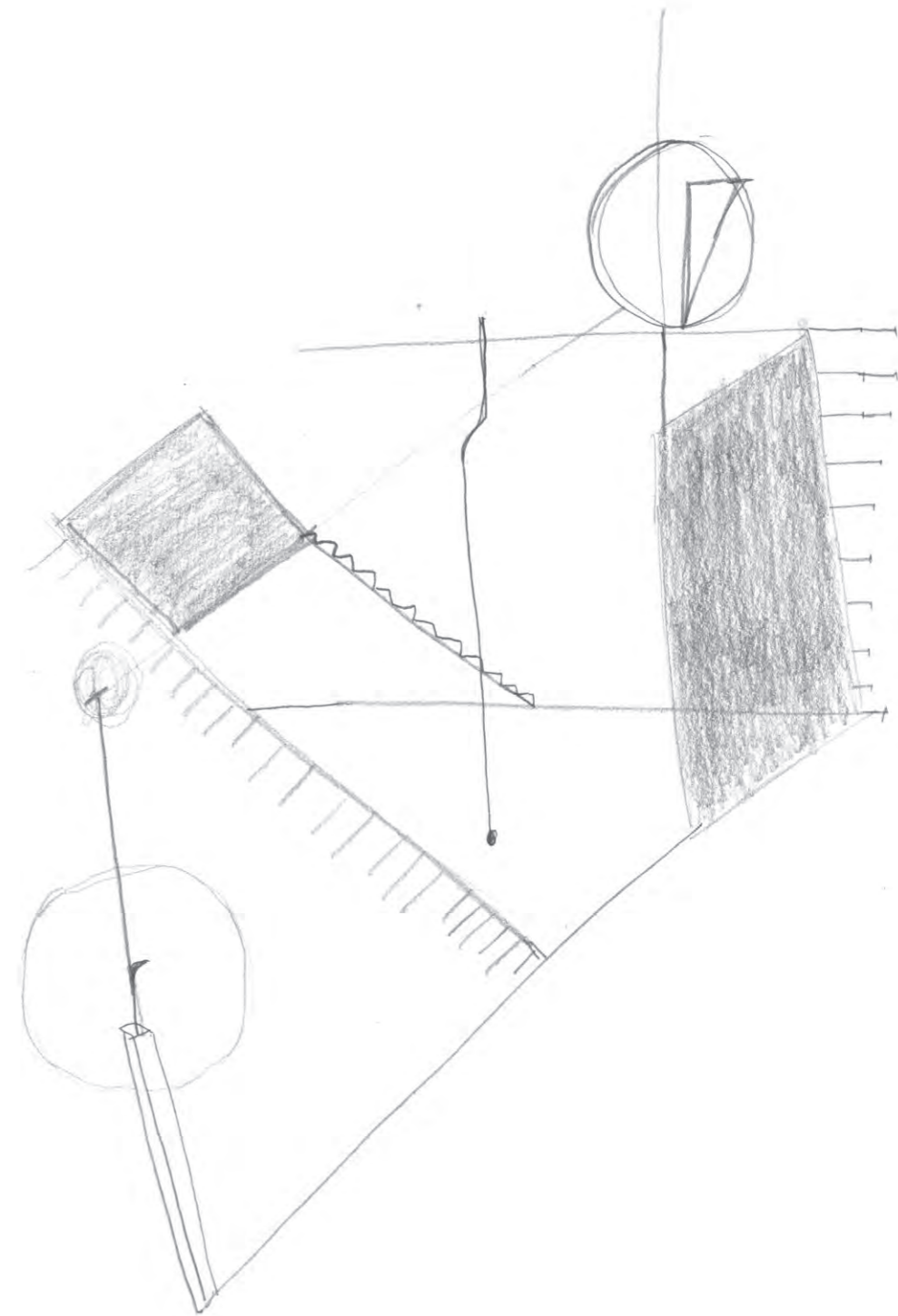



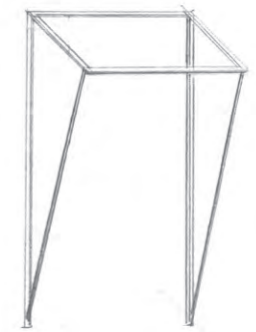
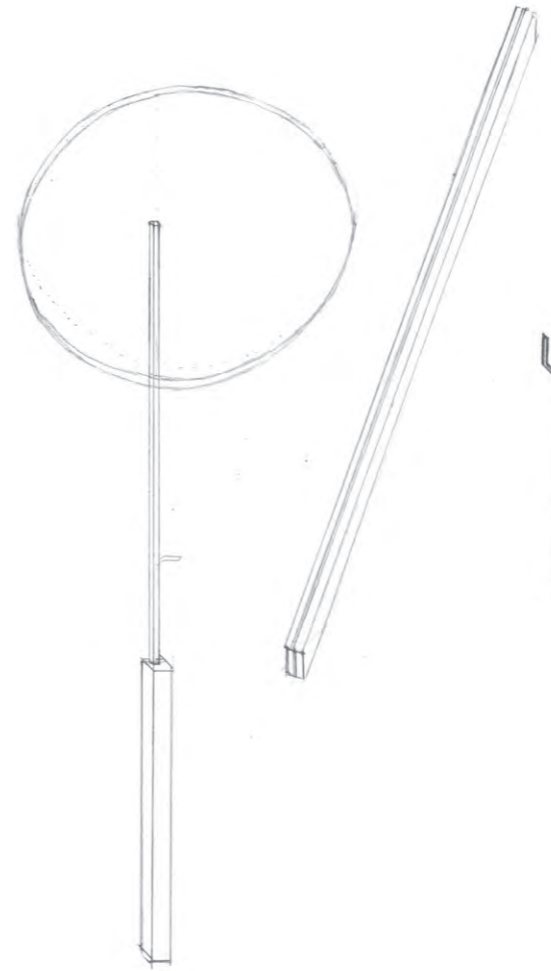
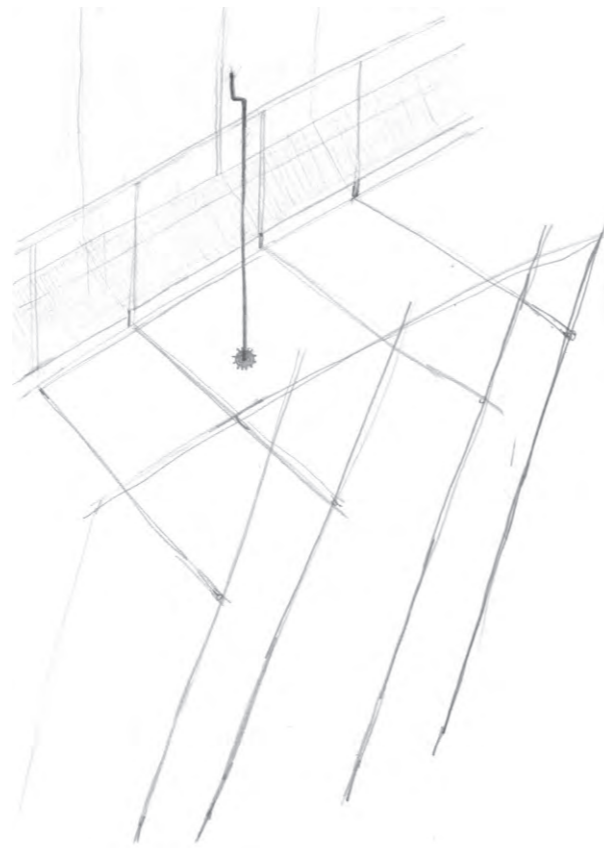
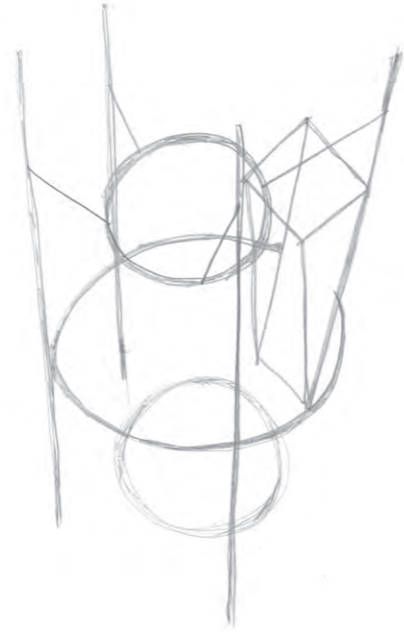
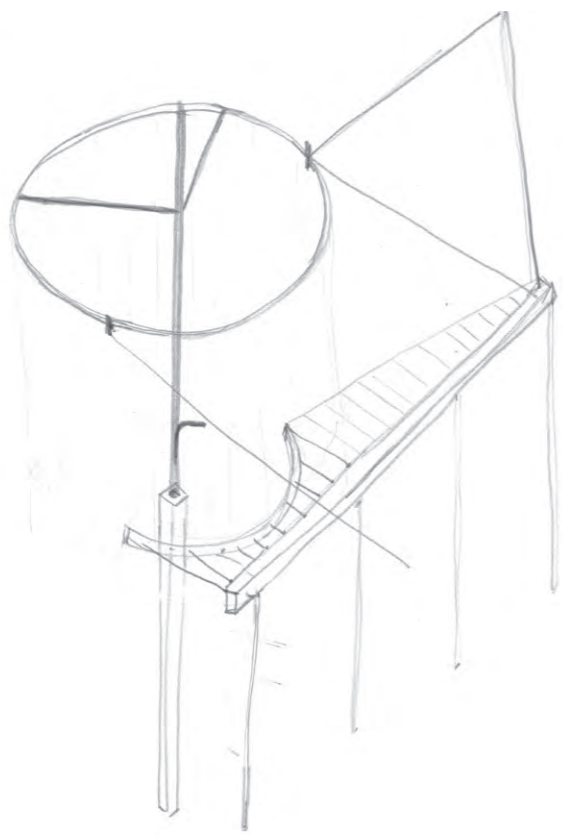

1.

**TO STUDY MAKE ARCHITECTURE, BUT
NOT FREED FROM THE PURELY OBJECTIVE.**





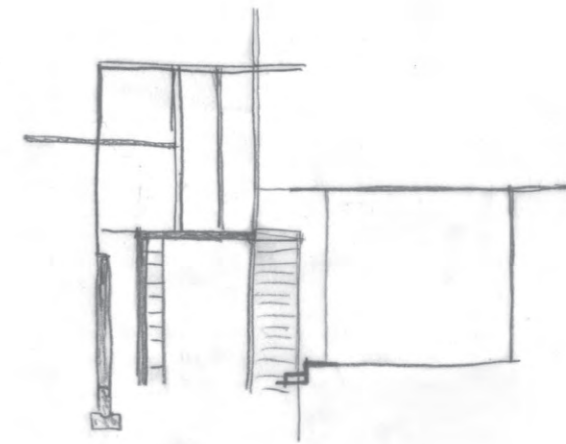

2.

**FROM ORIGINS OF ESSENTIAL NEEDS
WITHIN OF ARCHITECTURE WE EXPLORE "IN".**



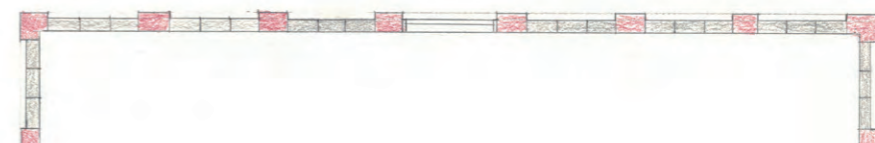
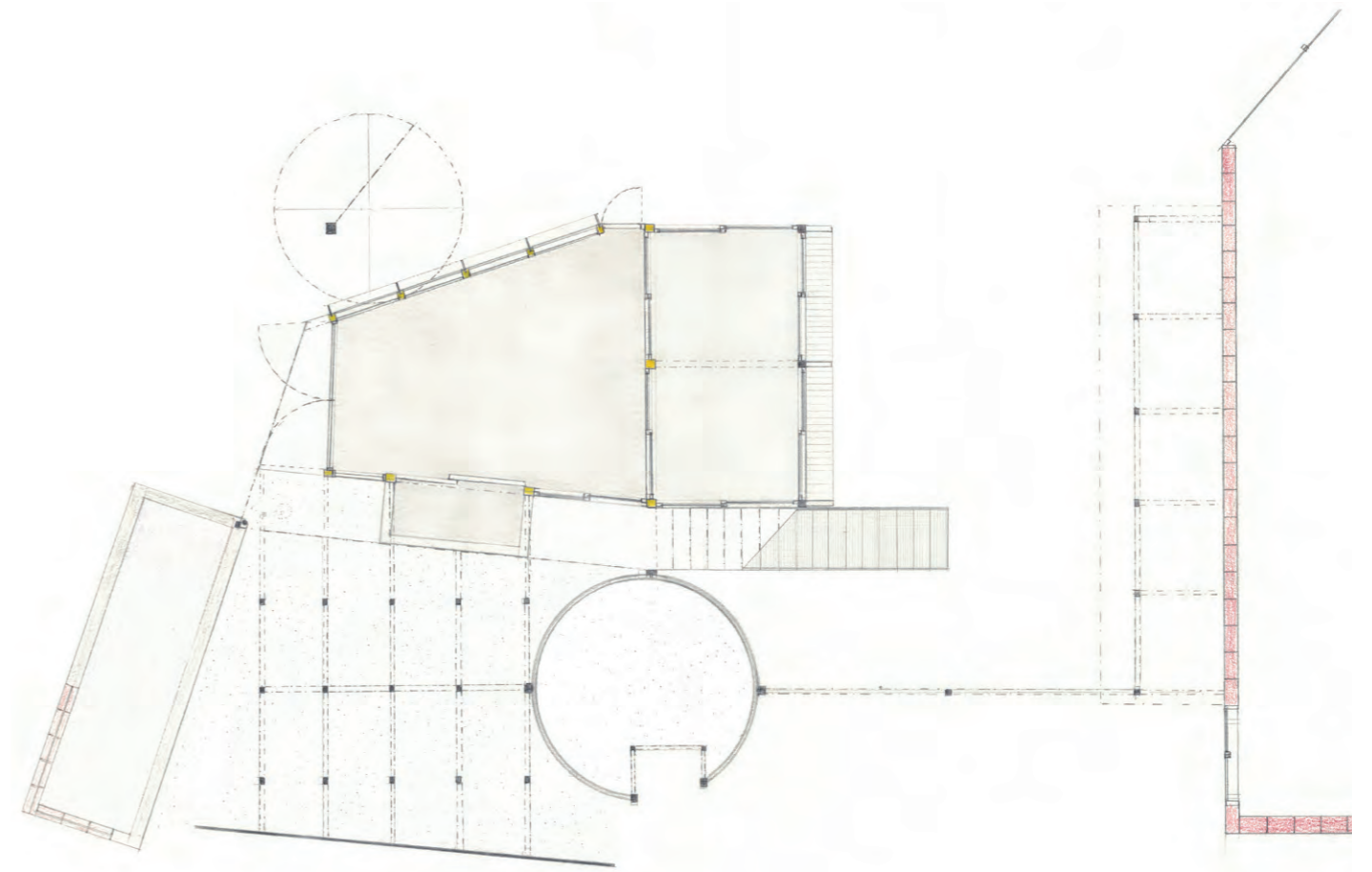
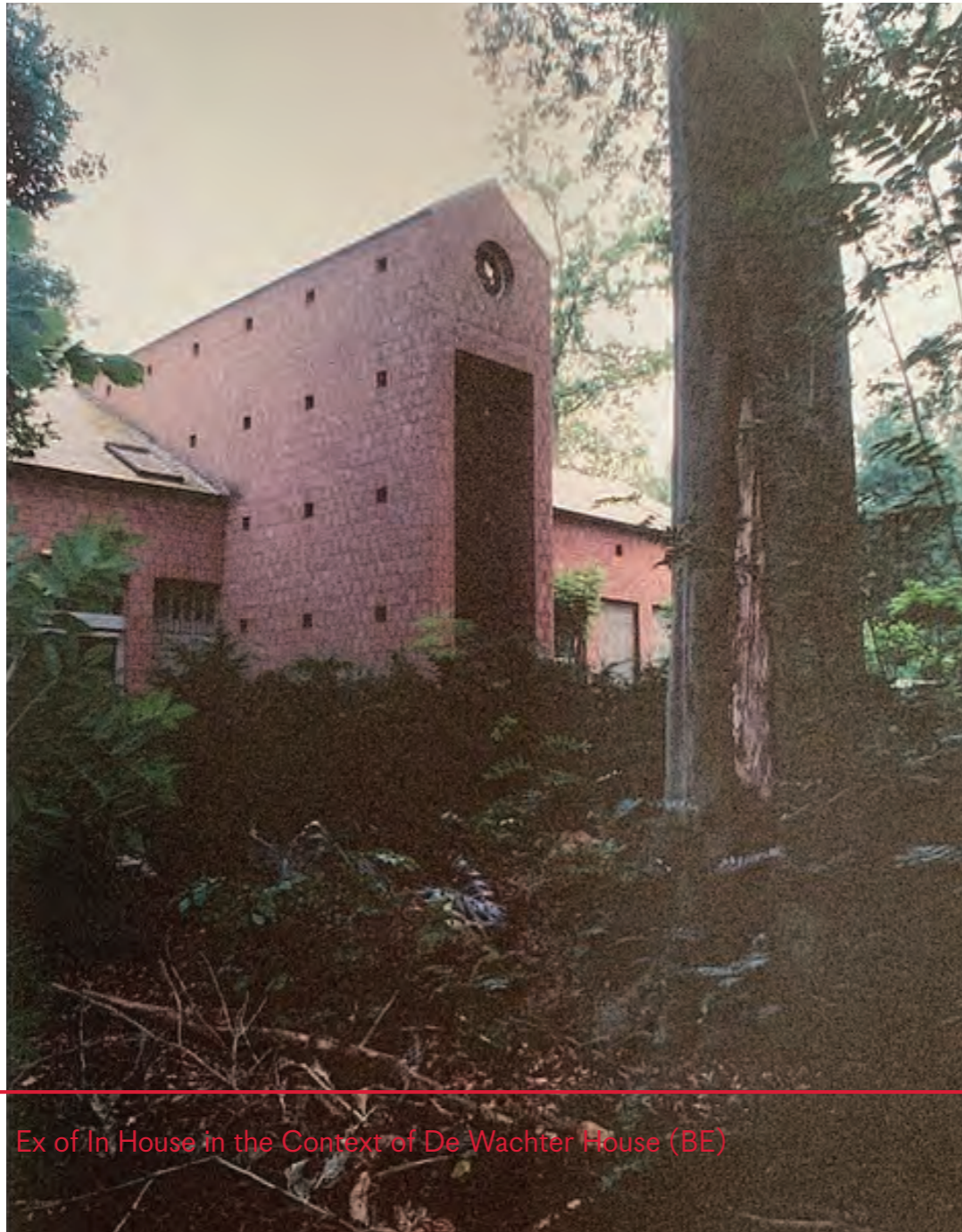

3.

“IN”: ALL SPACE IS SACRED SPACE.



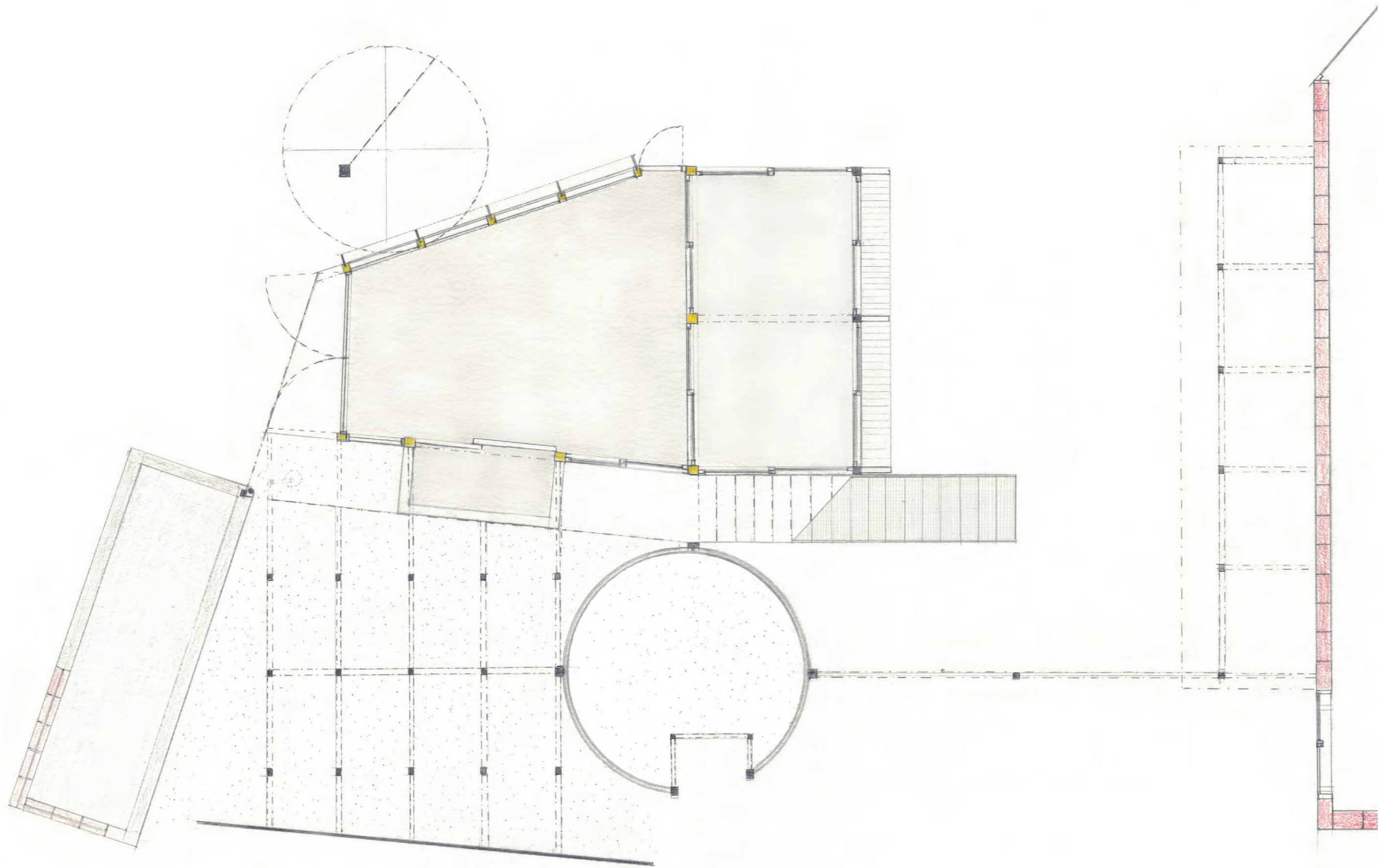

4.

**THE ARCHITECTURE OF “IN” DOMINATES
SPACE VIA SPACE. IN THERE SOMETHING
MIGHT BE GROWING.**





5.

**THE THING CONTAINING IS NOT THE
THING CONTAINED. NOTHING CAN
FOREVER BE CONTAINED.**



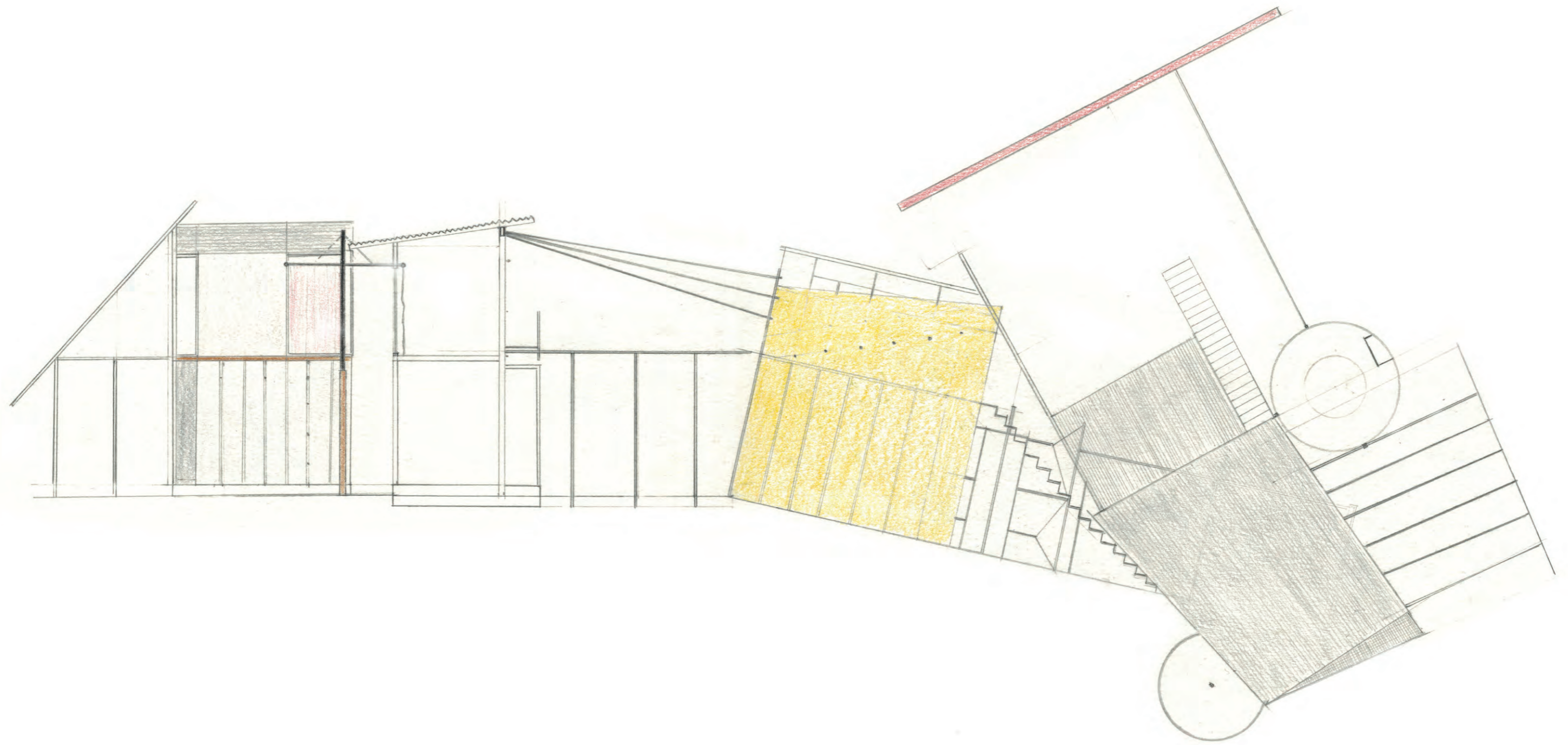

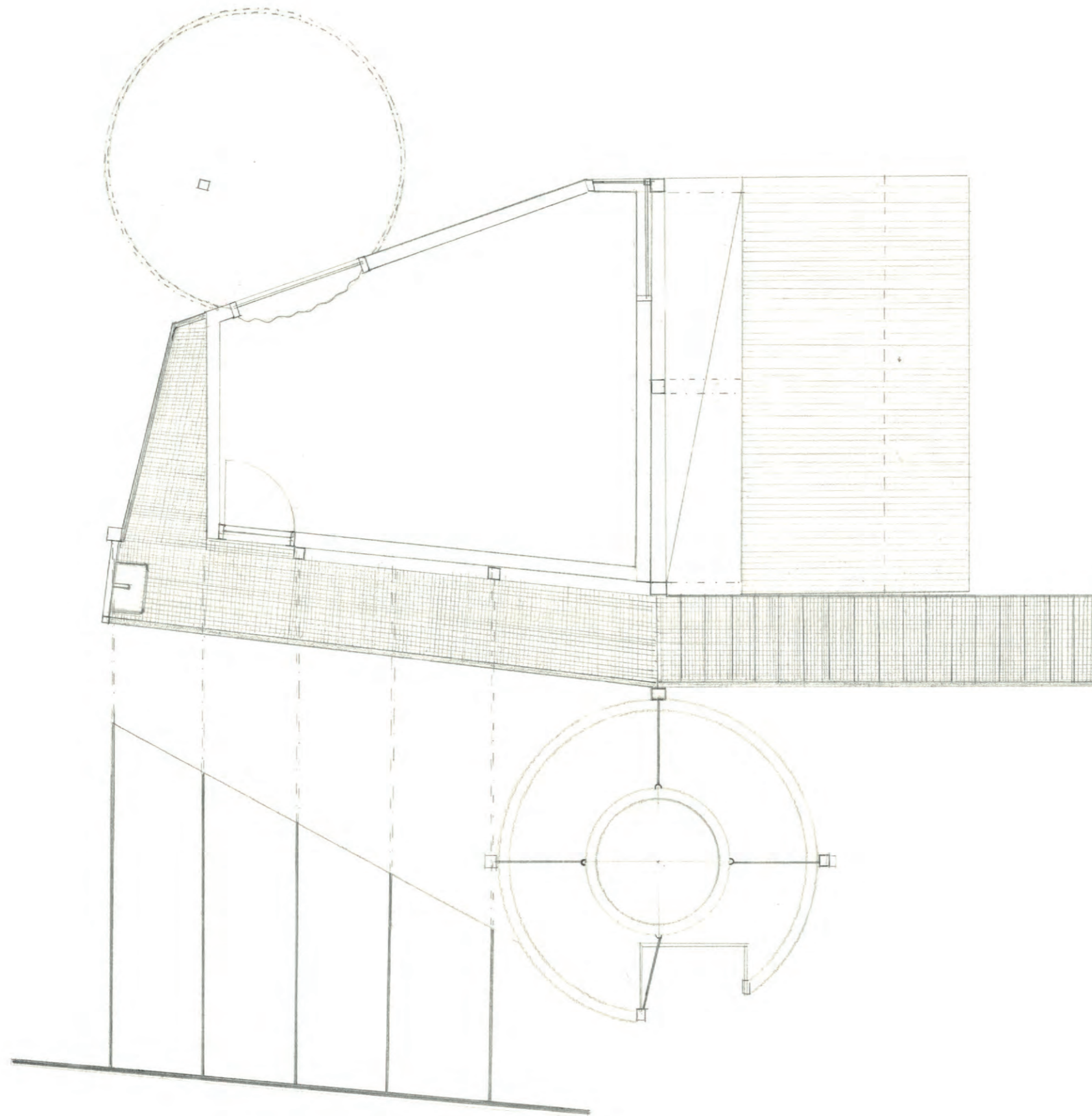

6.

**“IN” IS USELESS, BUT IN THE FUTURE
WILL BE USED, IF PURPOSE FINDS “IN”.**

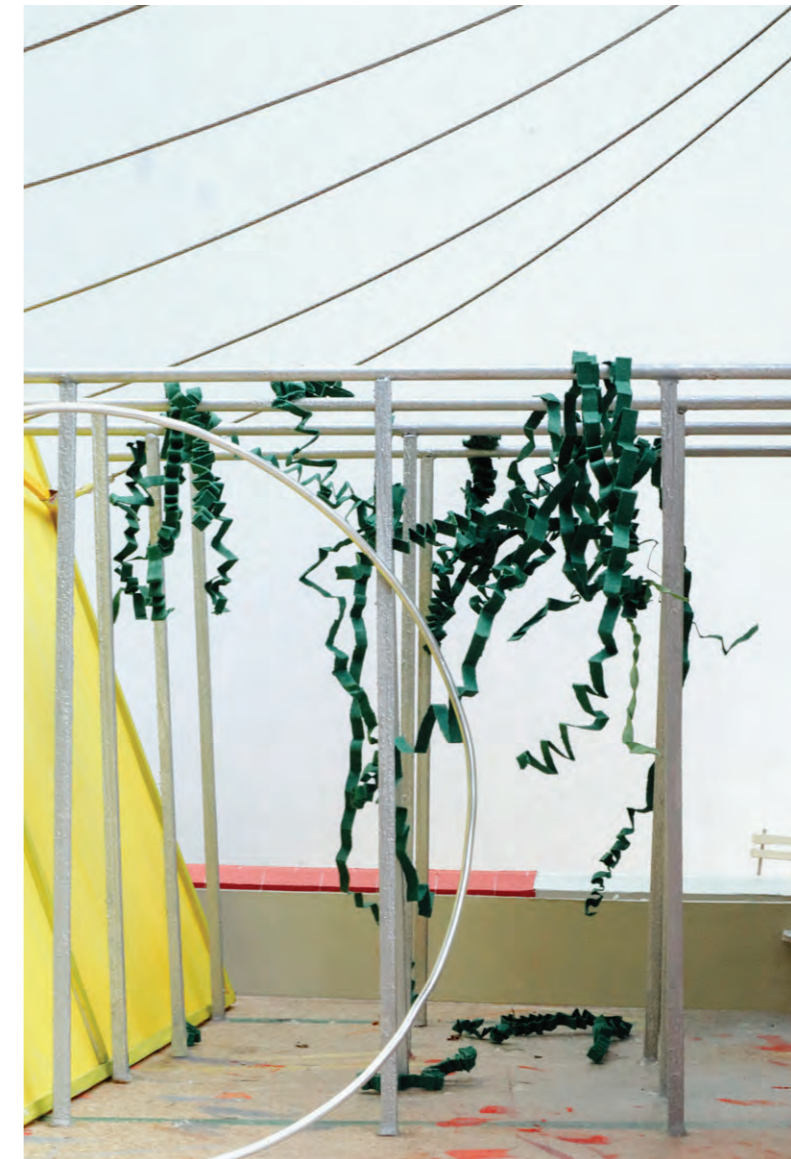

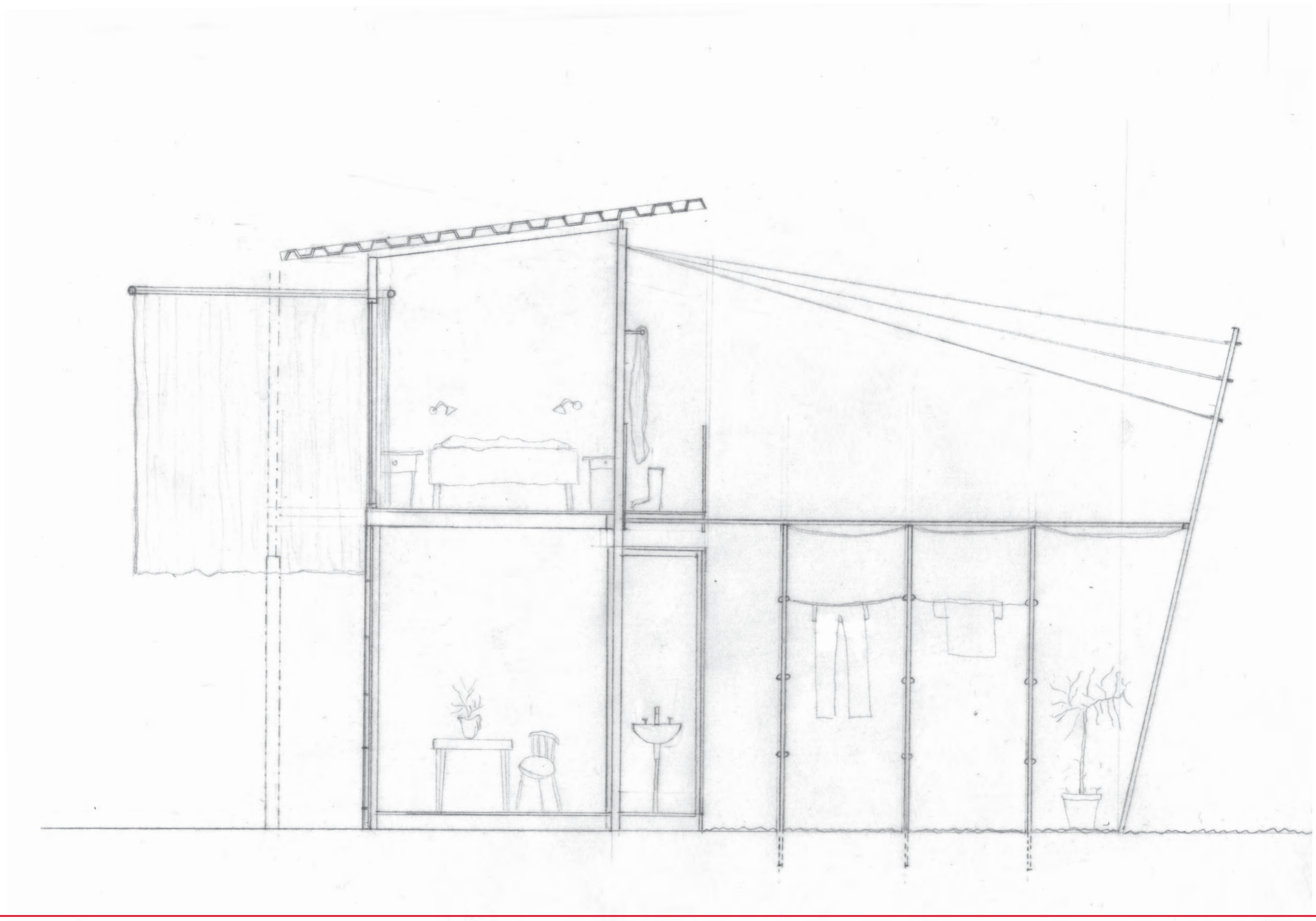

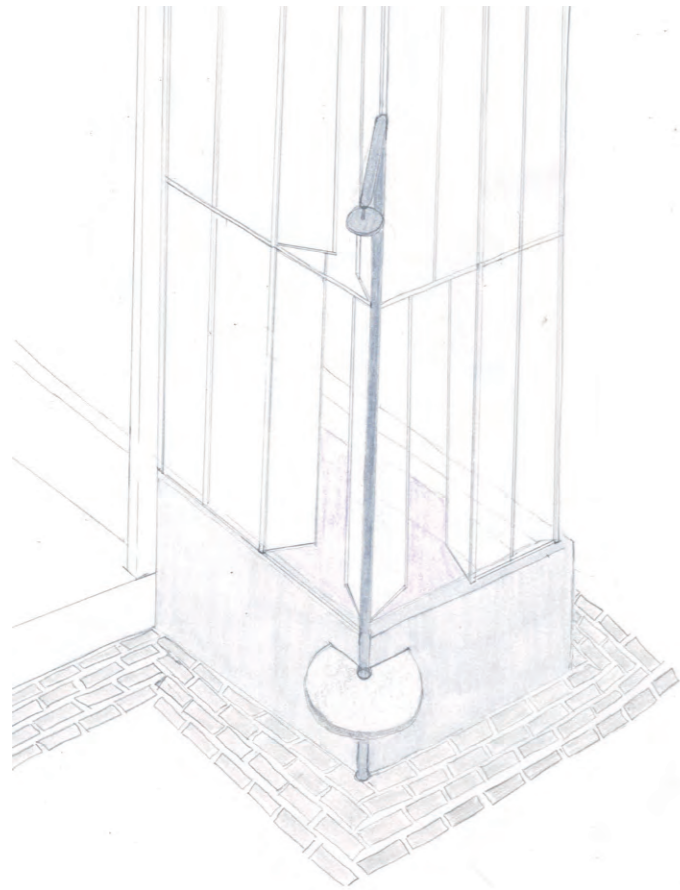

7.

**INTRINSIC "IN" IS AN ELEMENTAL FORCE
OF SENSUAL BEAUTY, BAUTY LIES
WHITHIN ALL.**

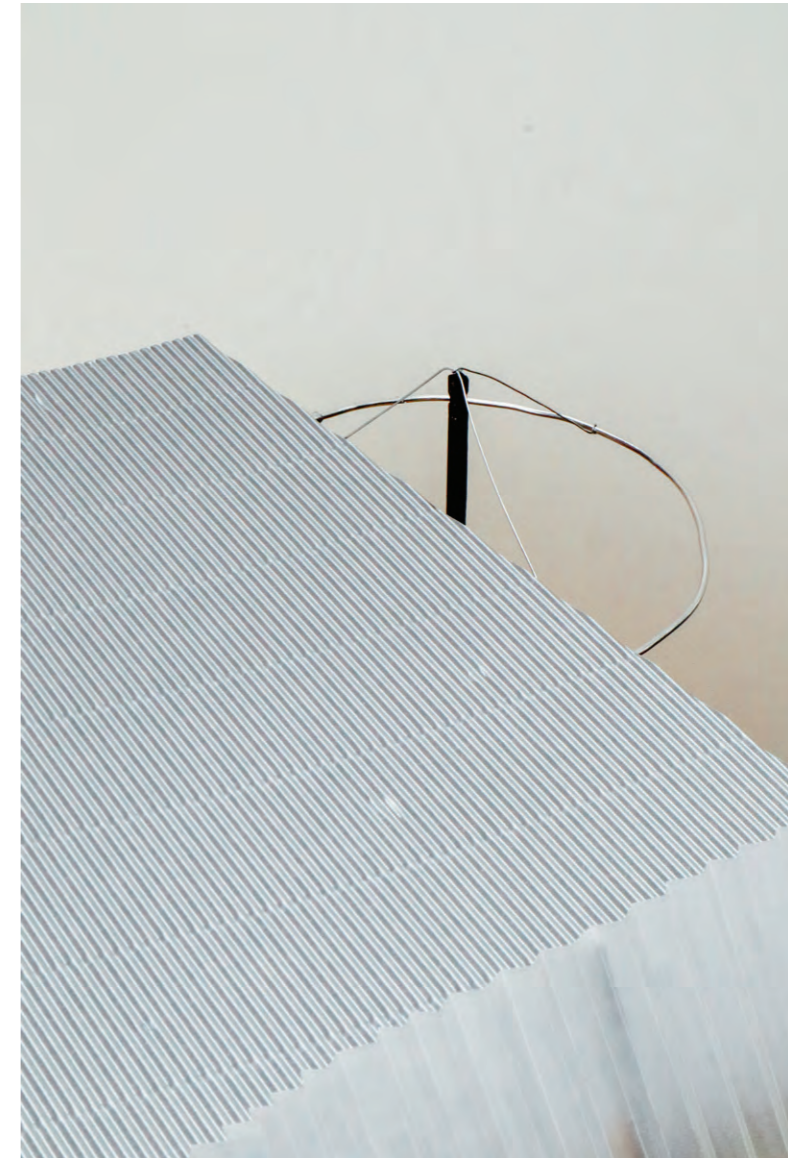

House for an Art Collector
in the context of
De Wachter House
(BE)

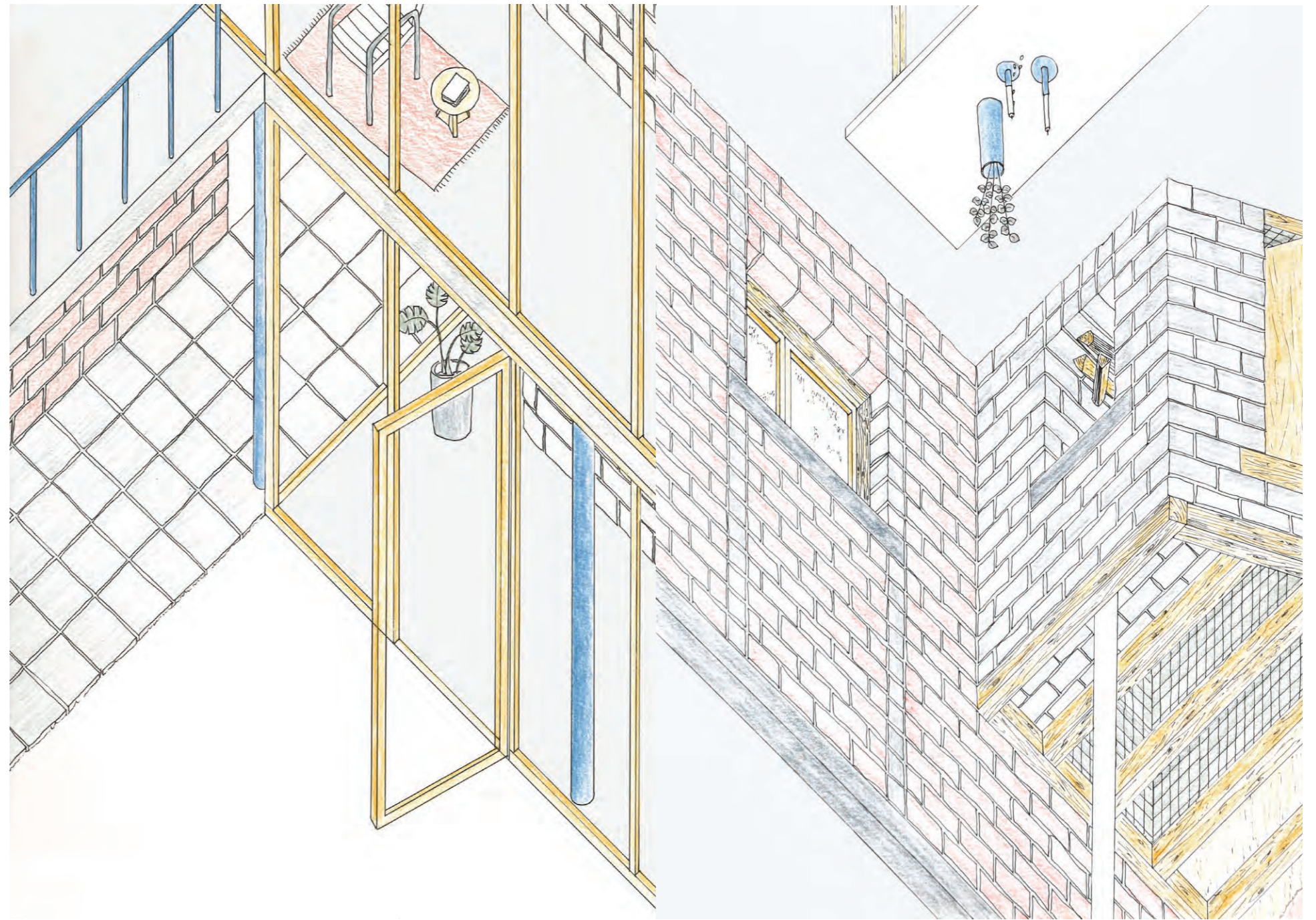



In the search of inspiration, House for a writer

As wide as my imagination can be, my life has always been about finding inspirations, new stories to tell. In this house, scenes appear in the frames disseminated along the way. Let me explain.

In the forest, i can suddenly see someone running away. I can see shapes moving through this window, going through the trees that get denser on the back.

The strong shape of my neighbor's house, gives me the perfect decor for a satiric piece on the Belgian bourgeoisie.

Anyway, i will not expand on that because the list is endless.

Maybe like my House.

Endless, as I can walk in there hour after hour. From the street to my bedroom. From the bedroom to the courtyard. From the courtyard to the kitchen. From a corridor to larger space, and then some stairs, then again a generous courtyard. This loop is a sequence, like the one my stories are creating inside my head.

And then sometimes the scenes are colliding into each other, and that is where the heart of my stories lies.

A theater, a stair, a platform. A path, a terrasse, a window. And there it begins.

1 Bricks combination on the inside, making the space

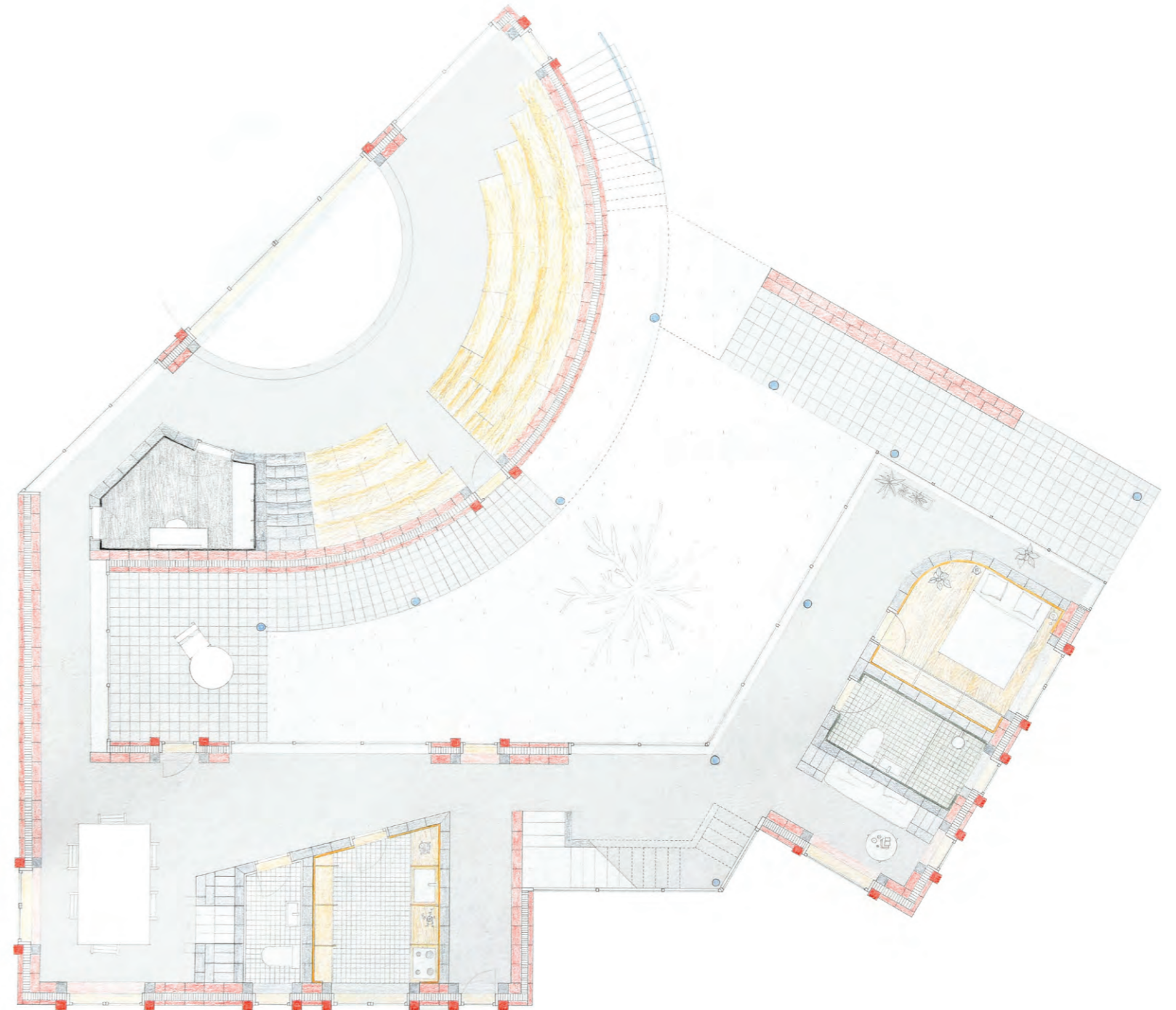

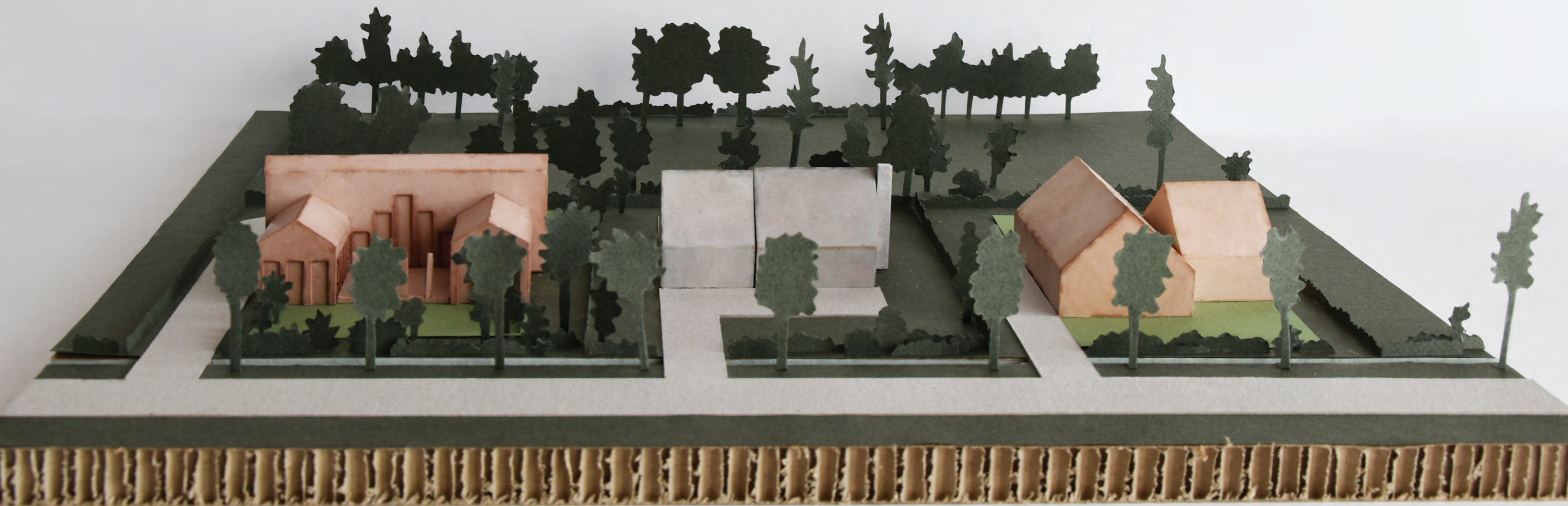



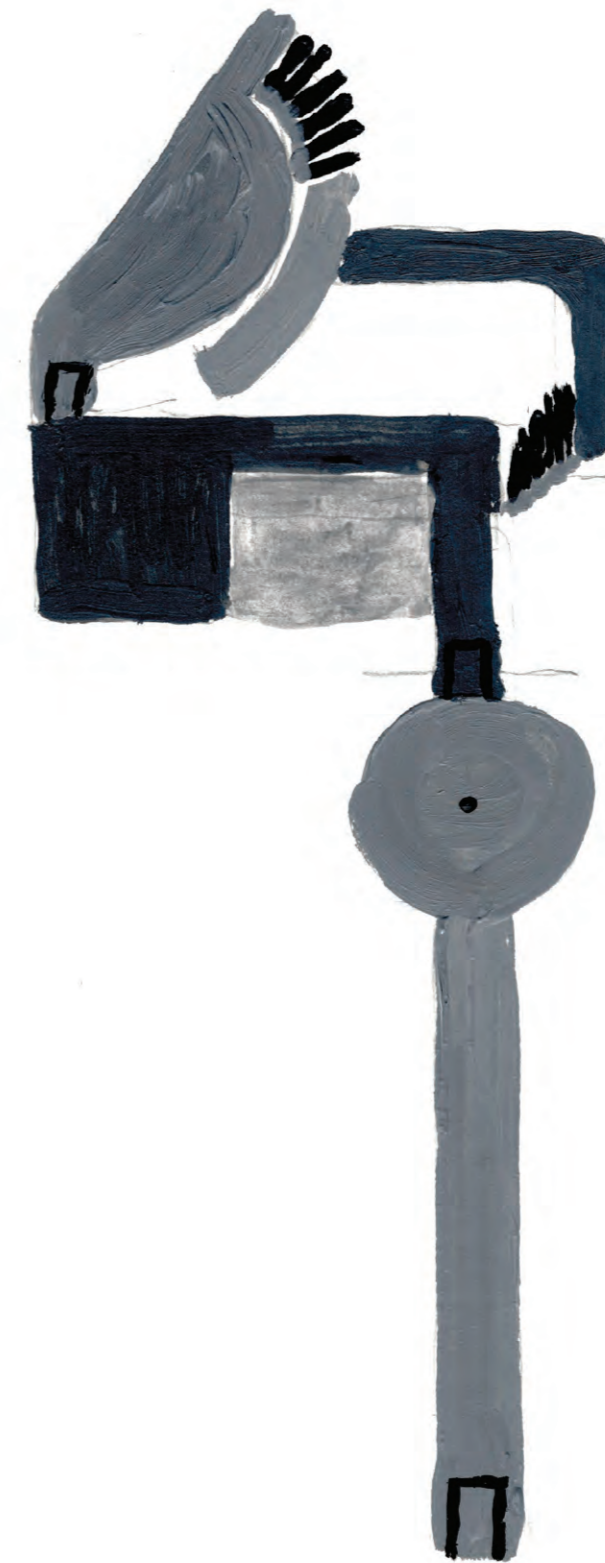
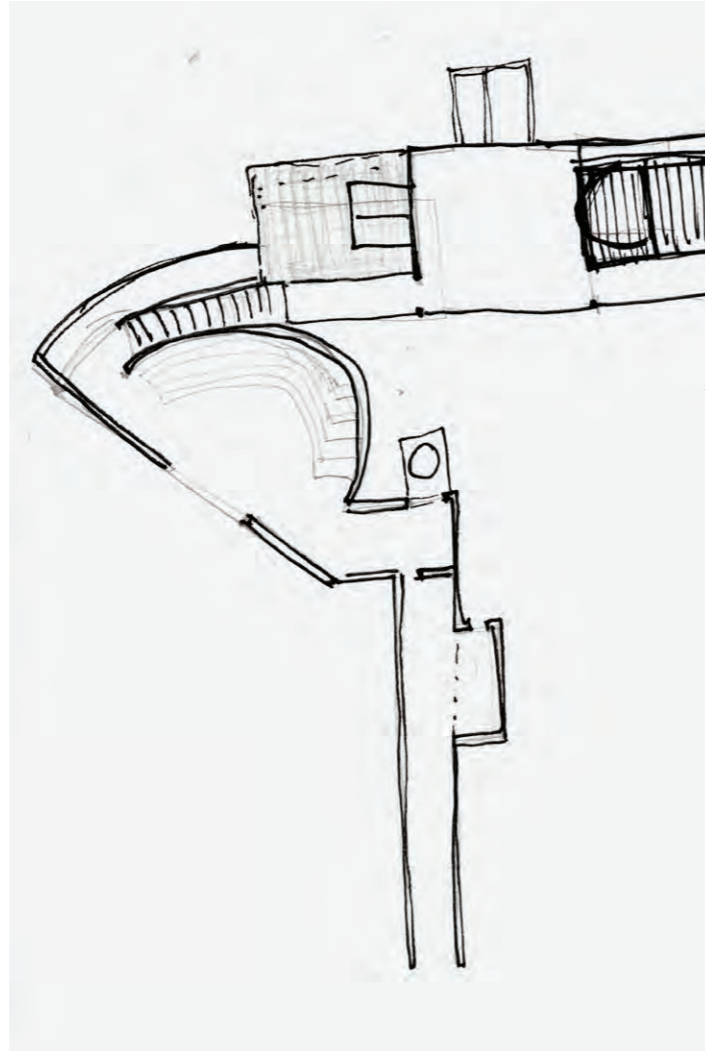
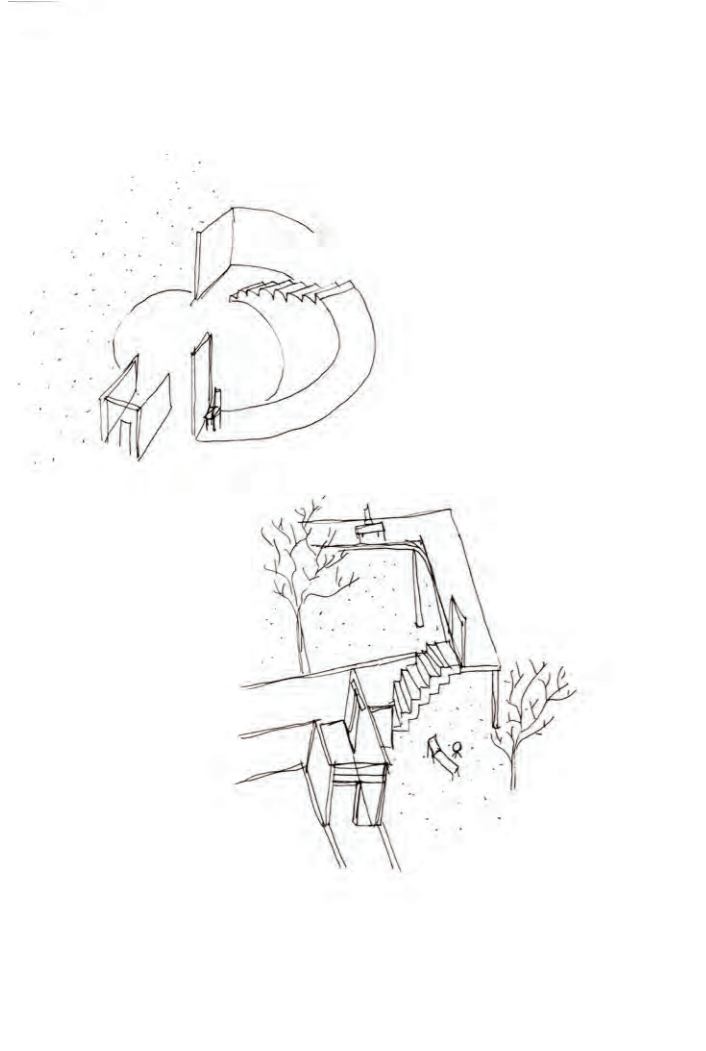
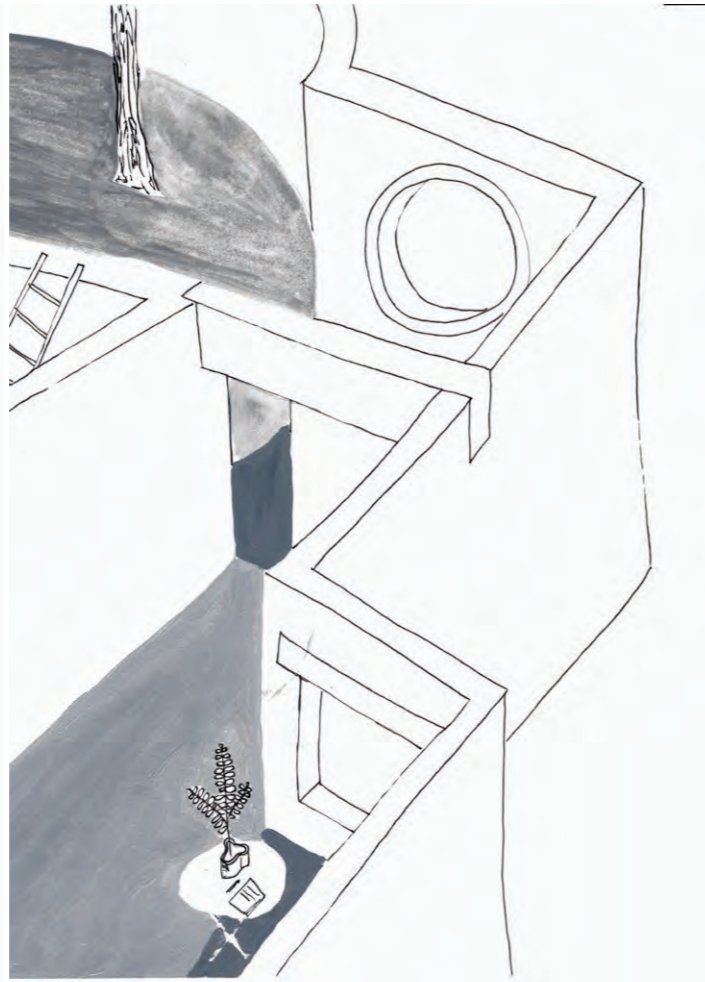
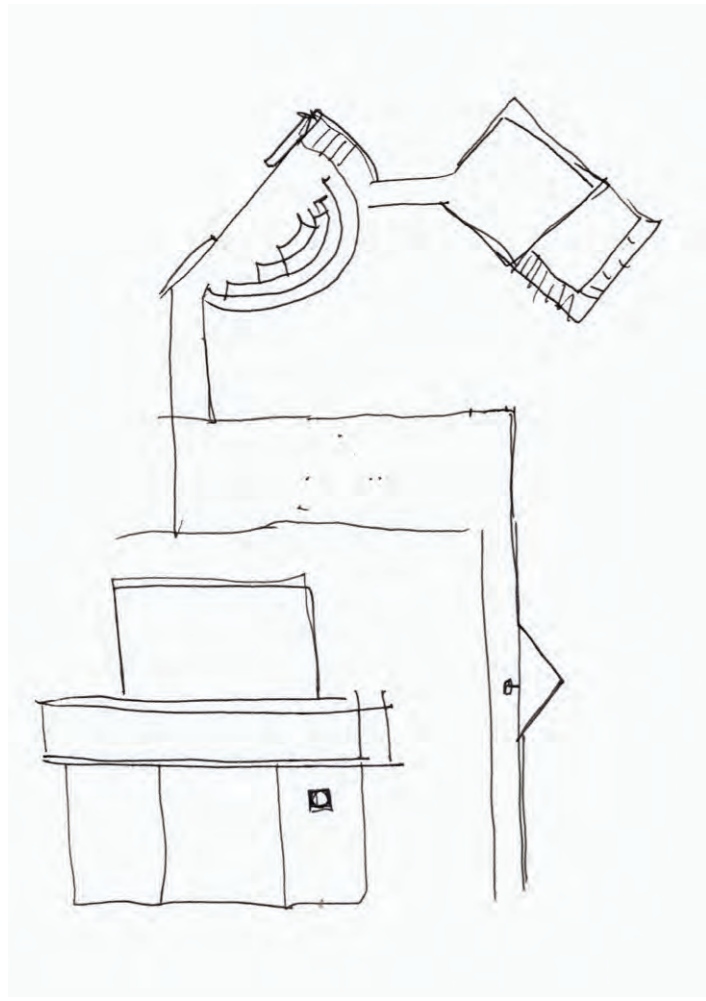

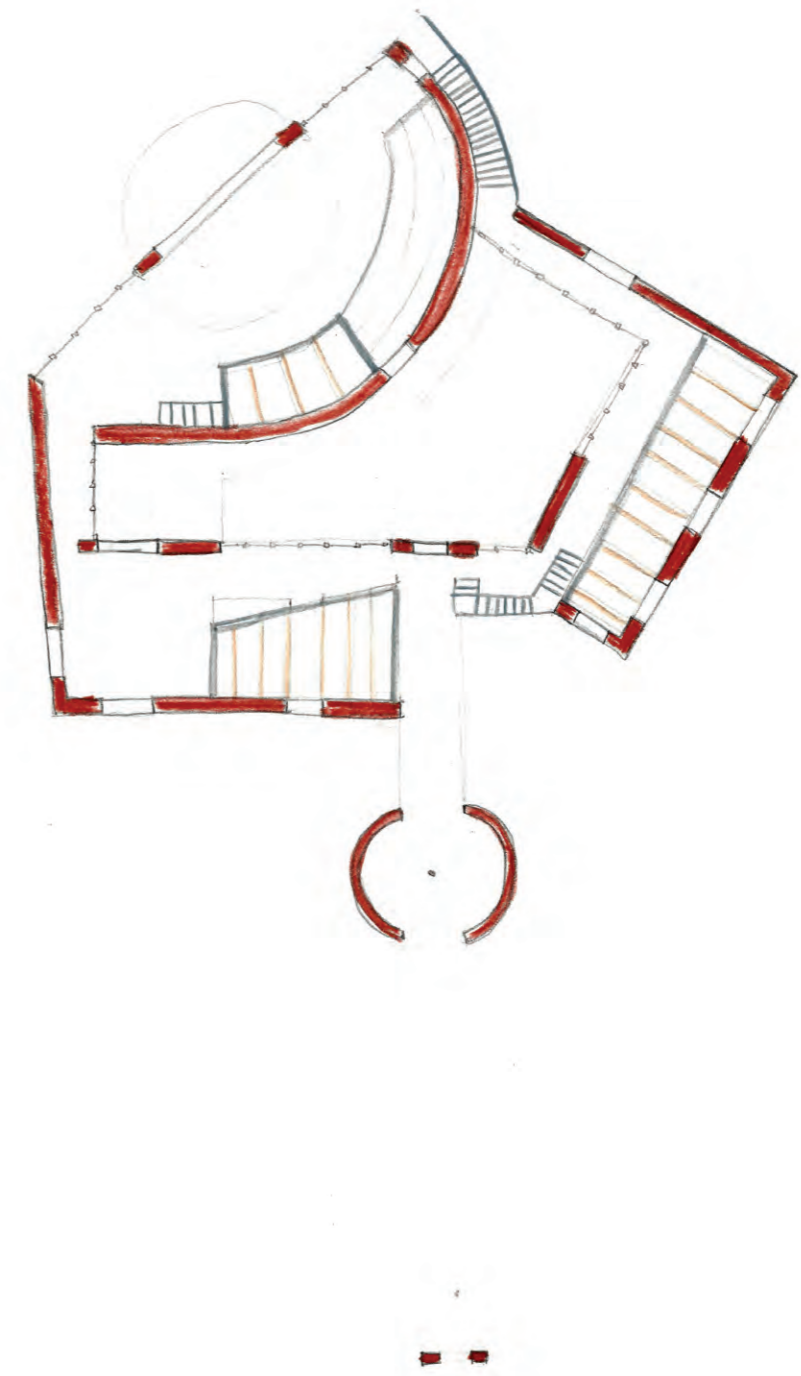





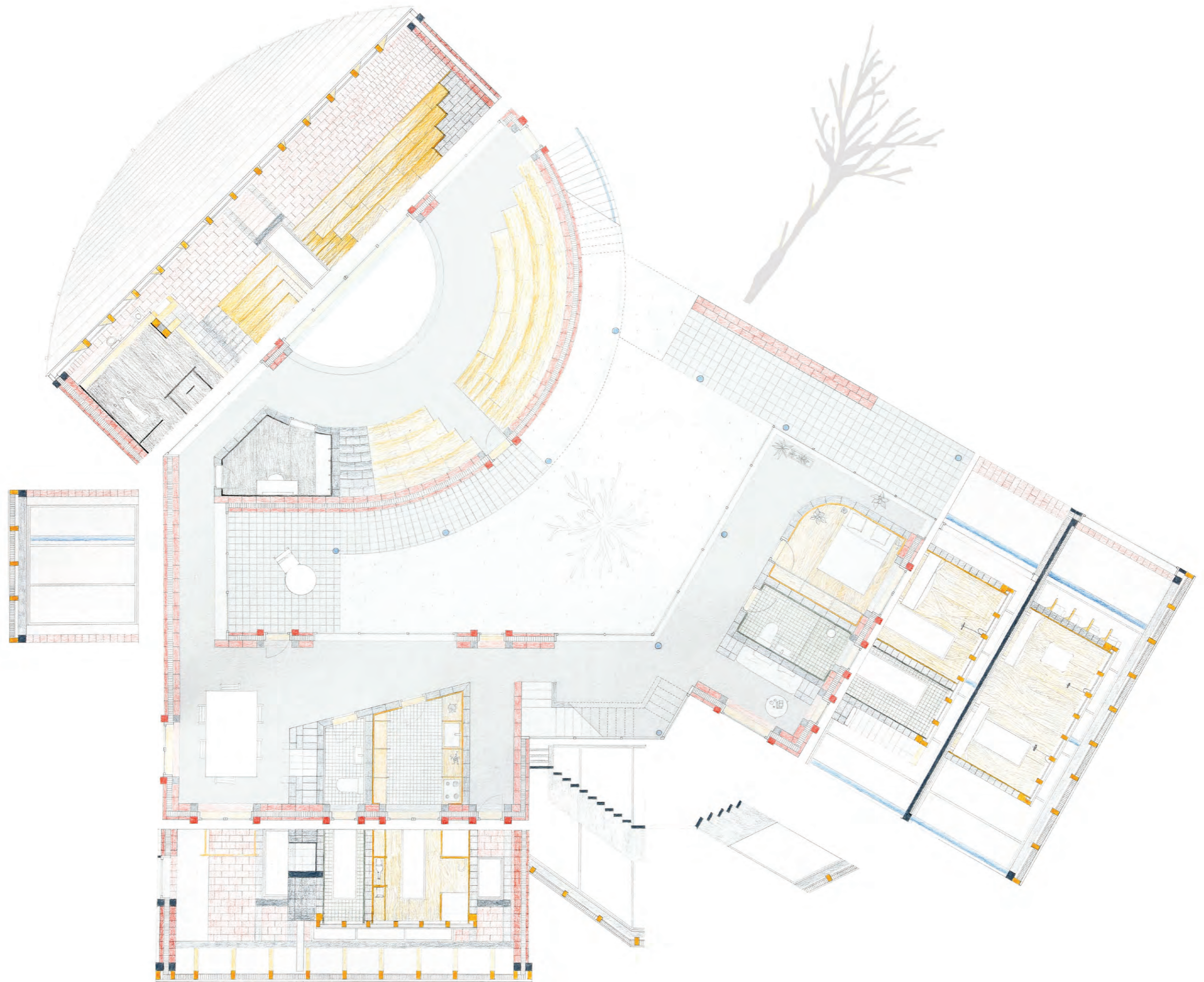

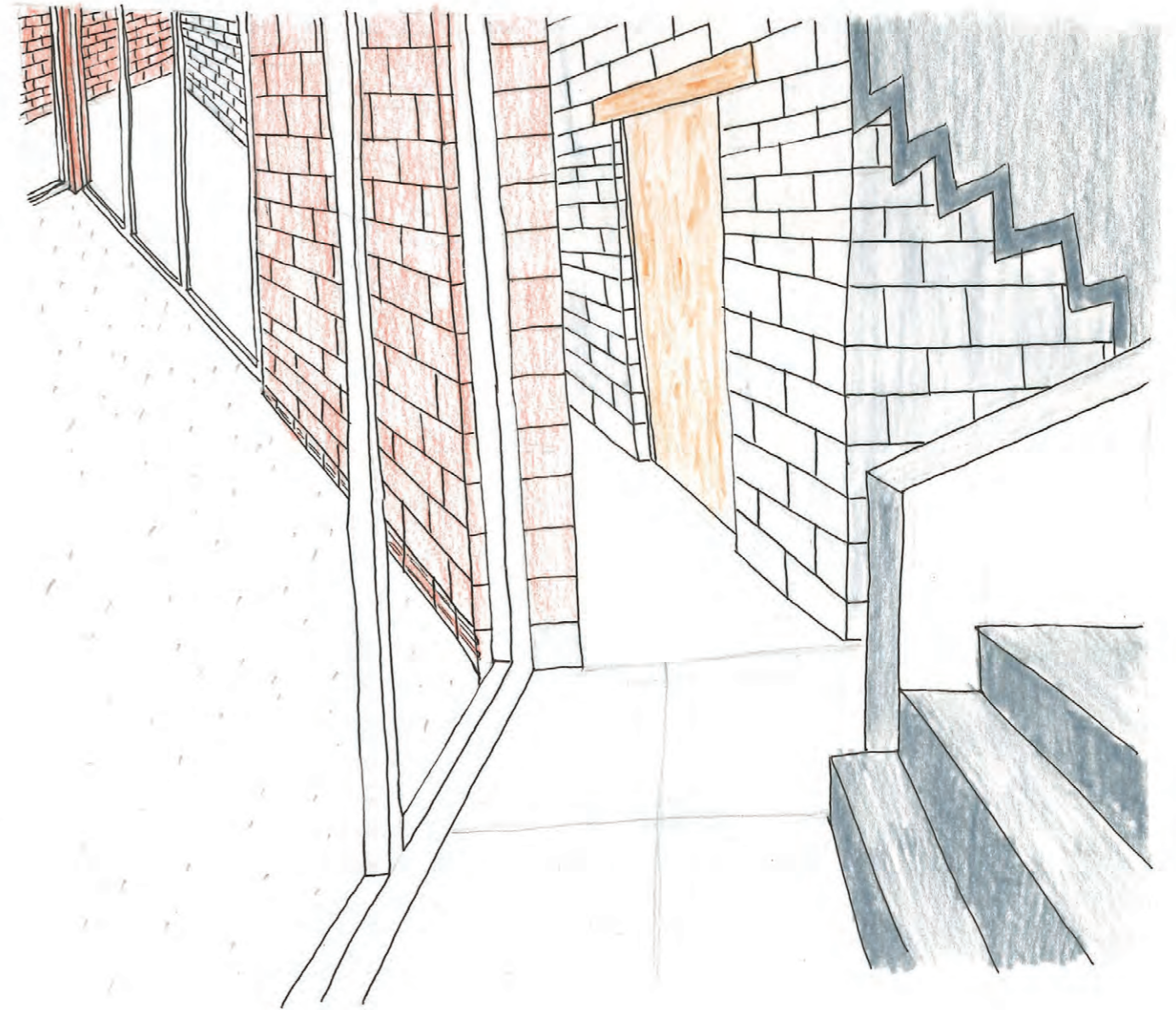
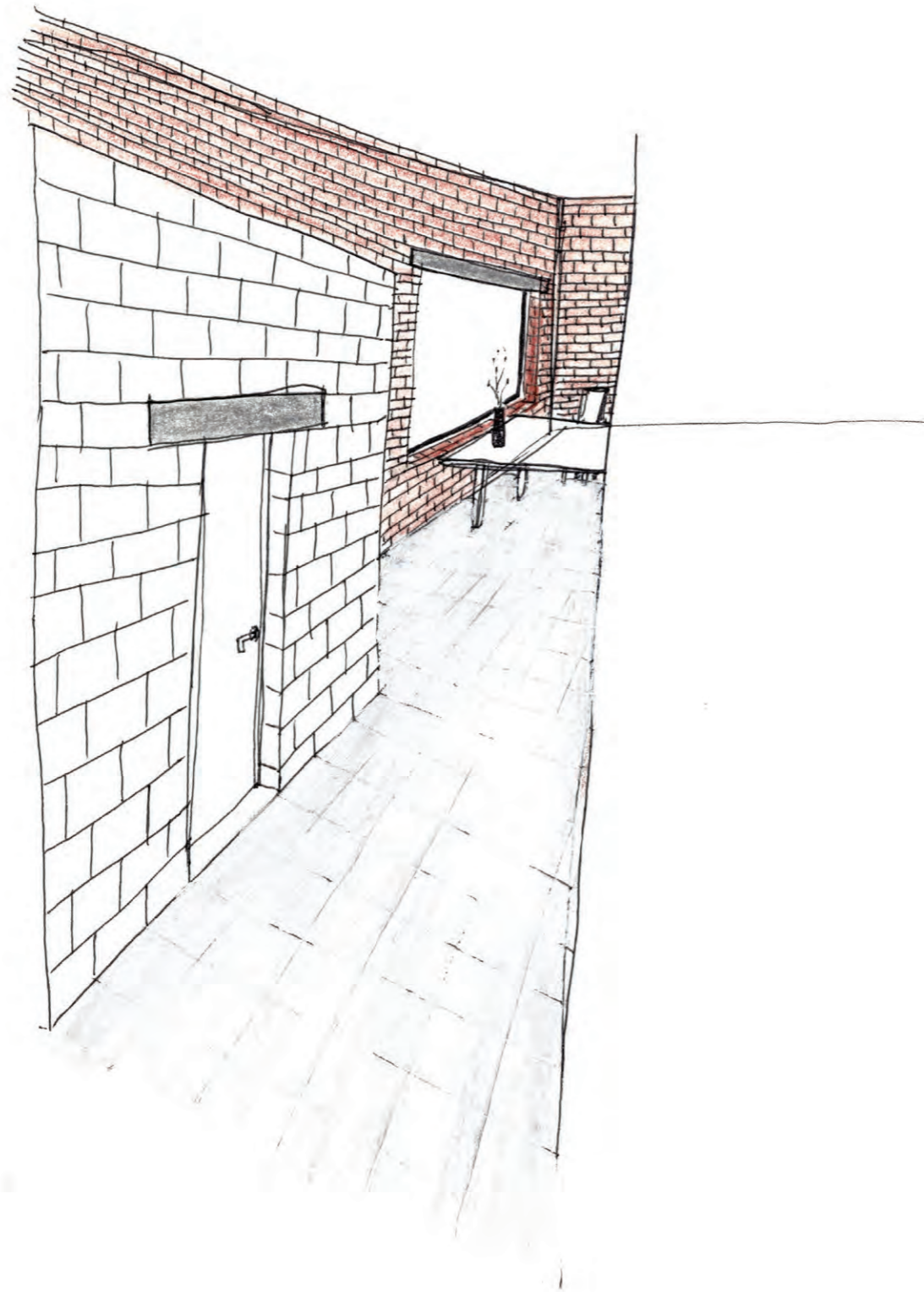

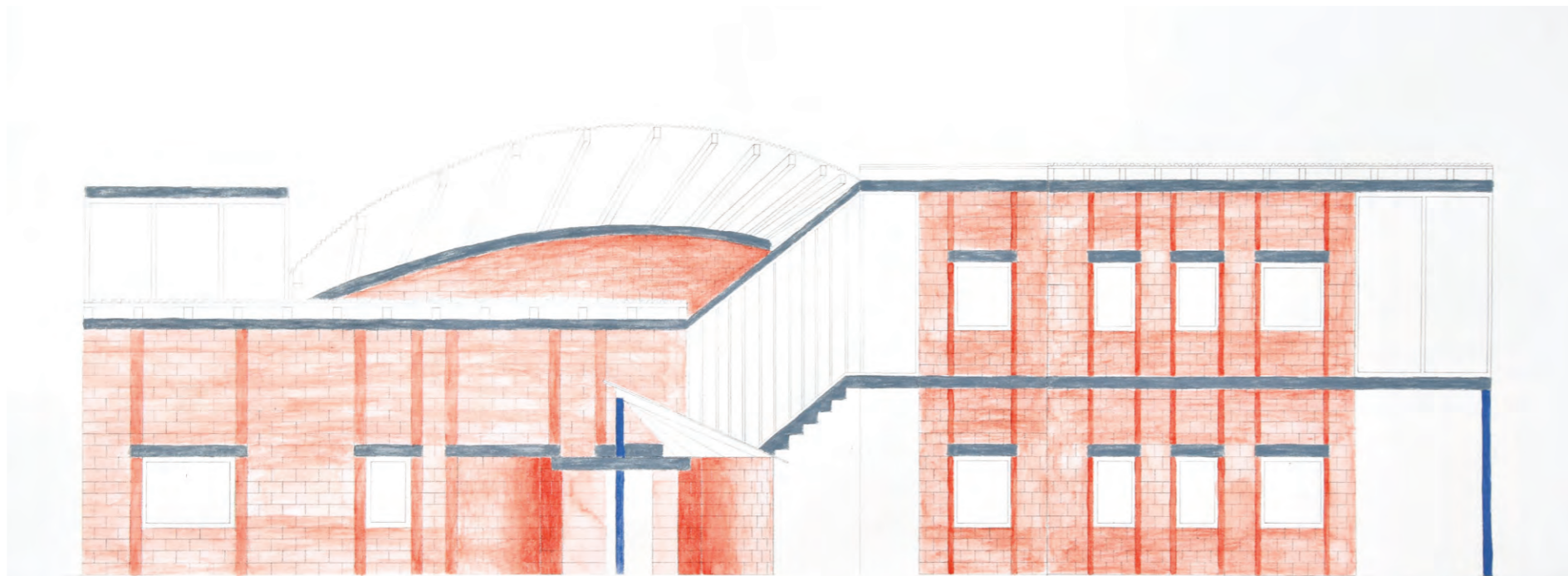

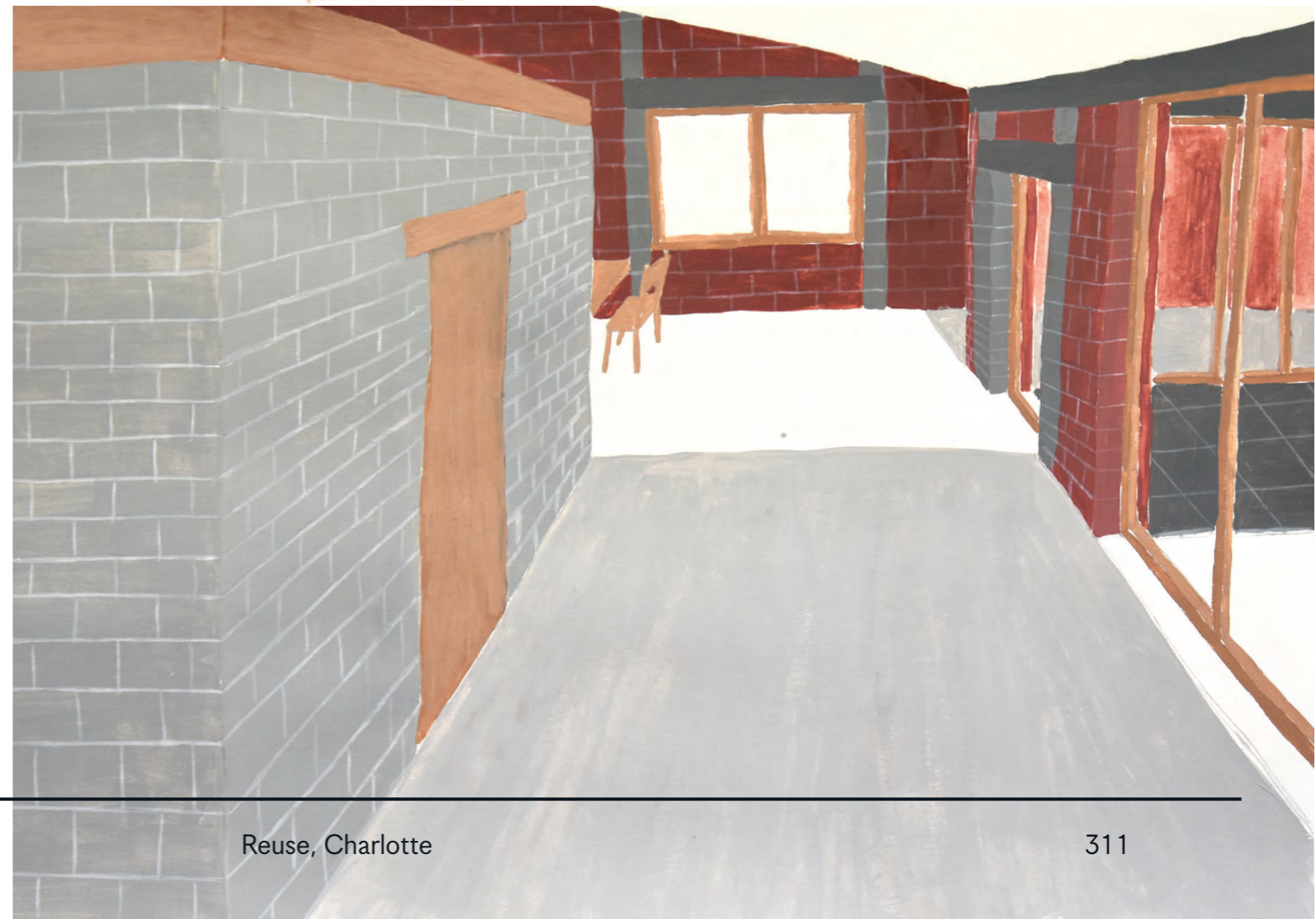
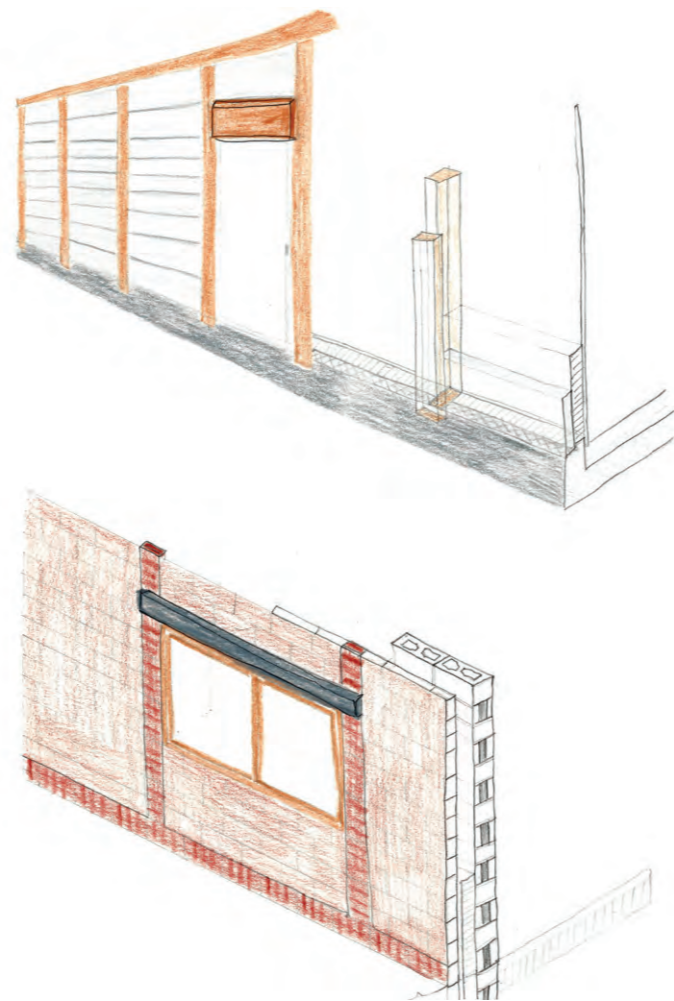
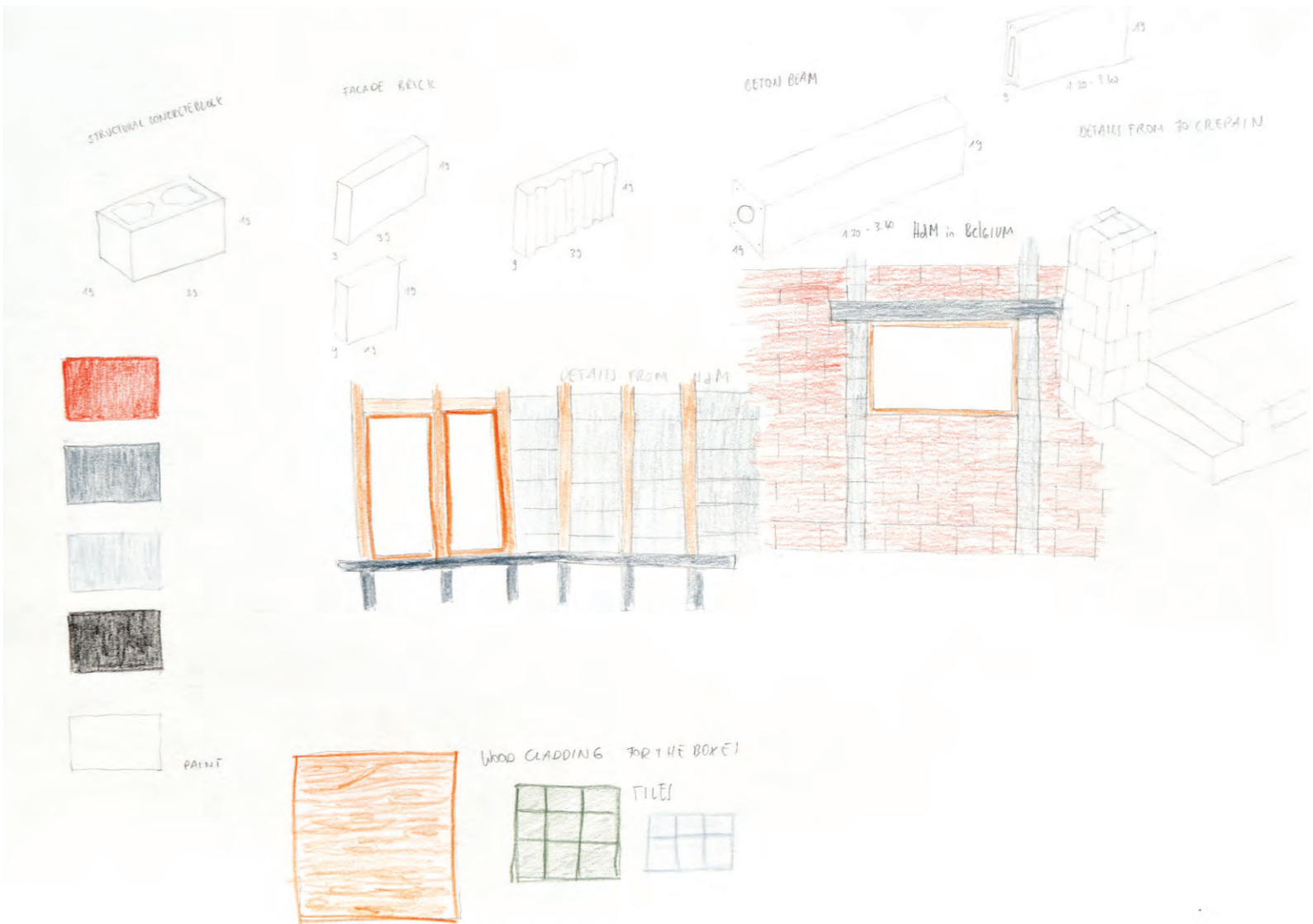

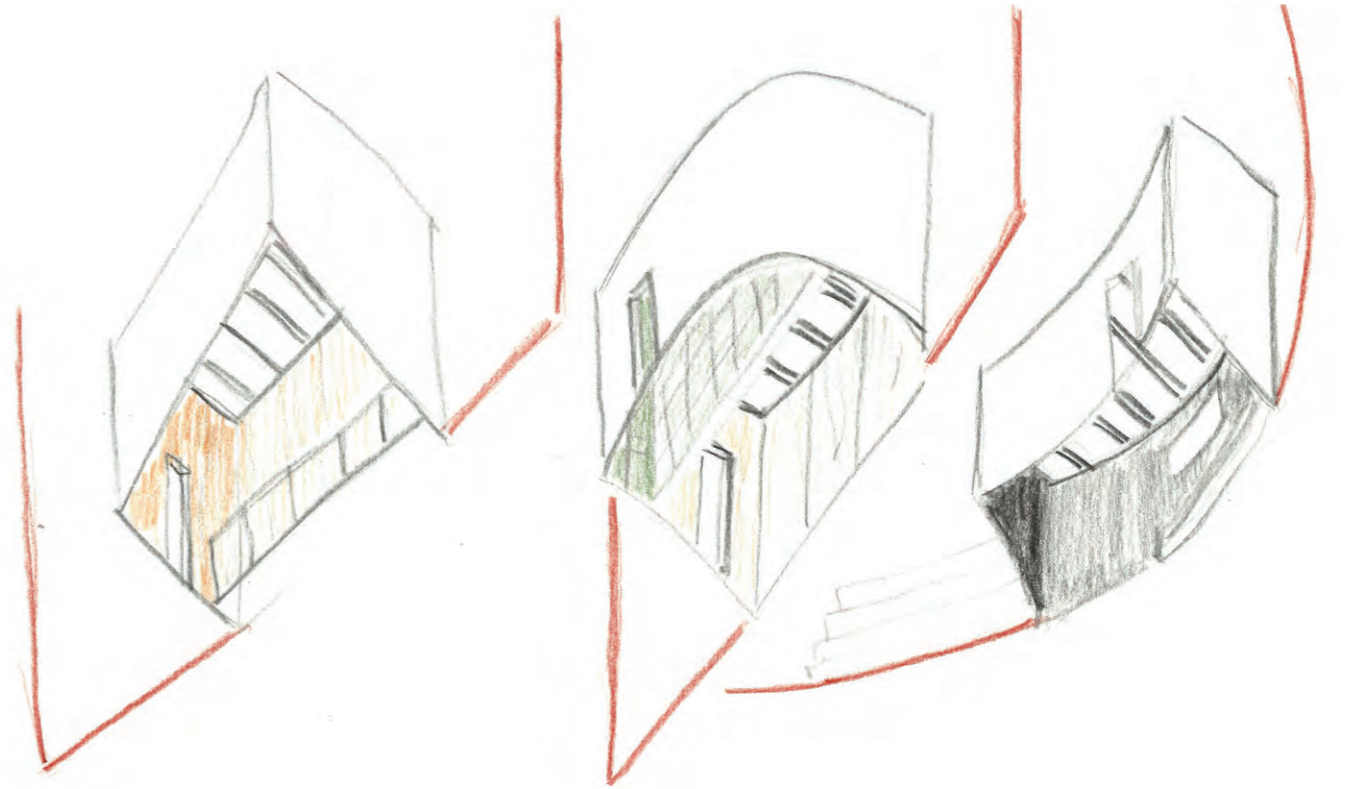

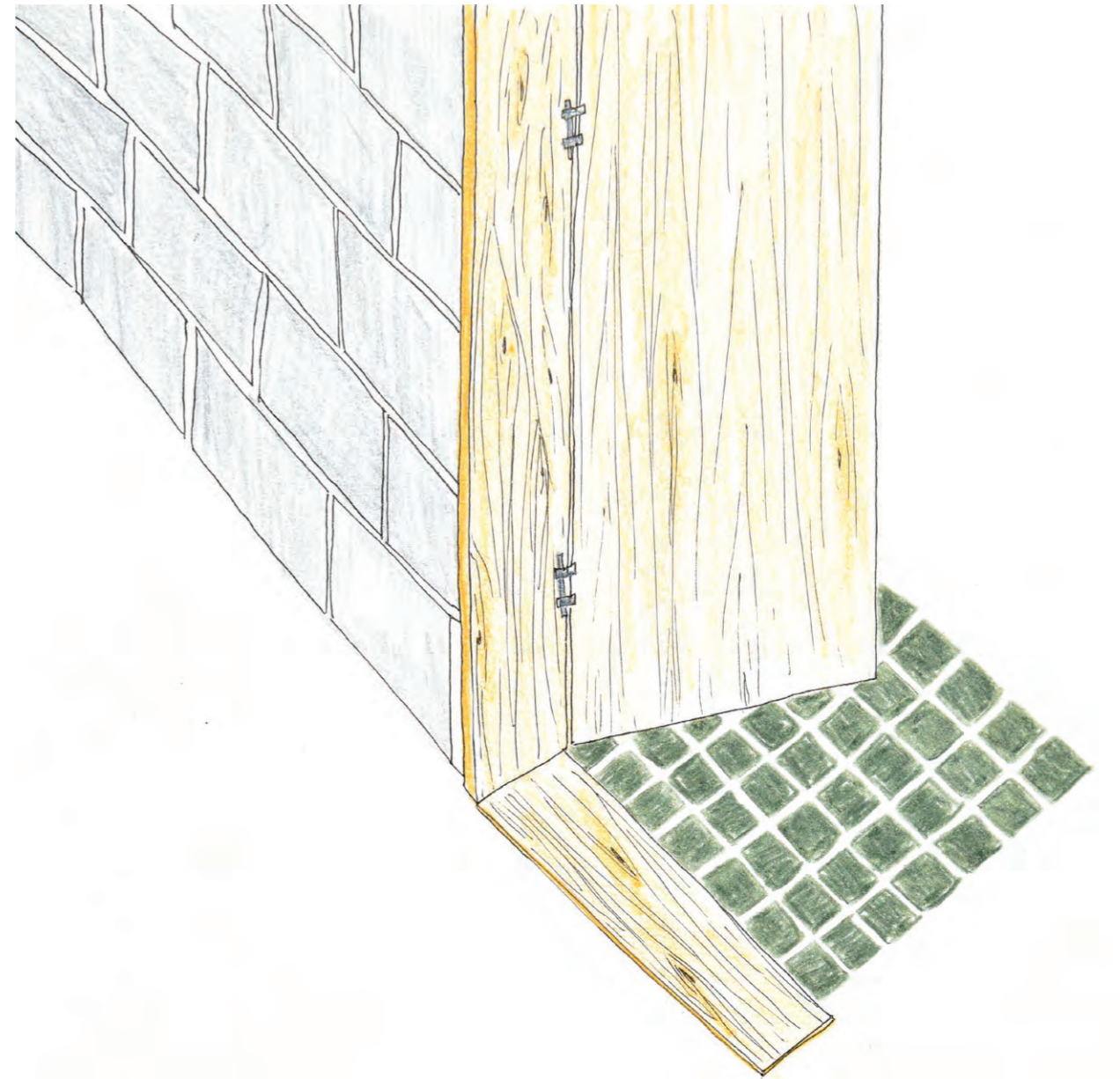

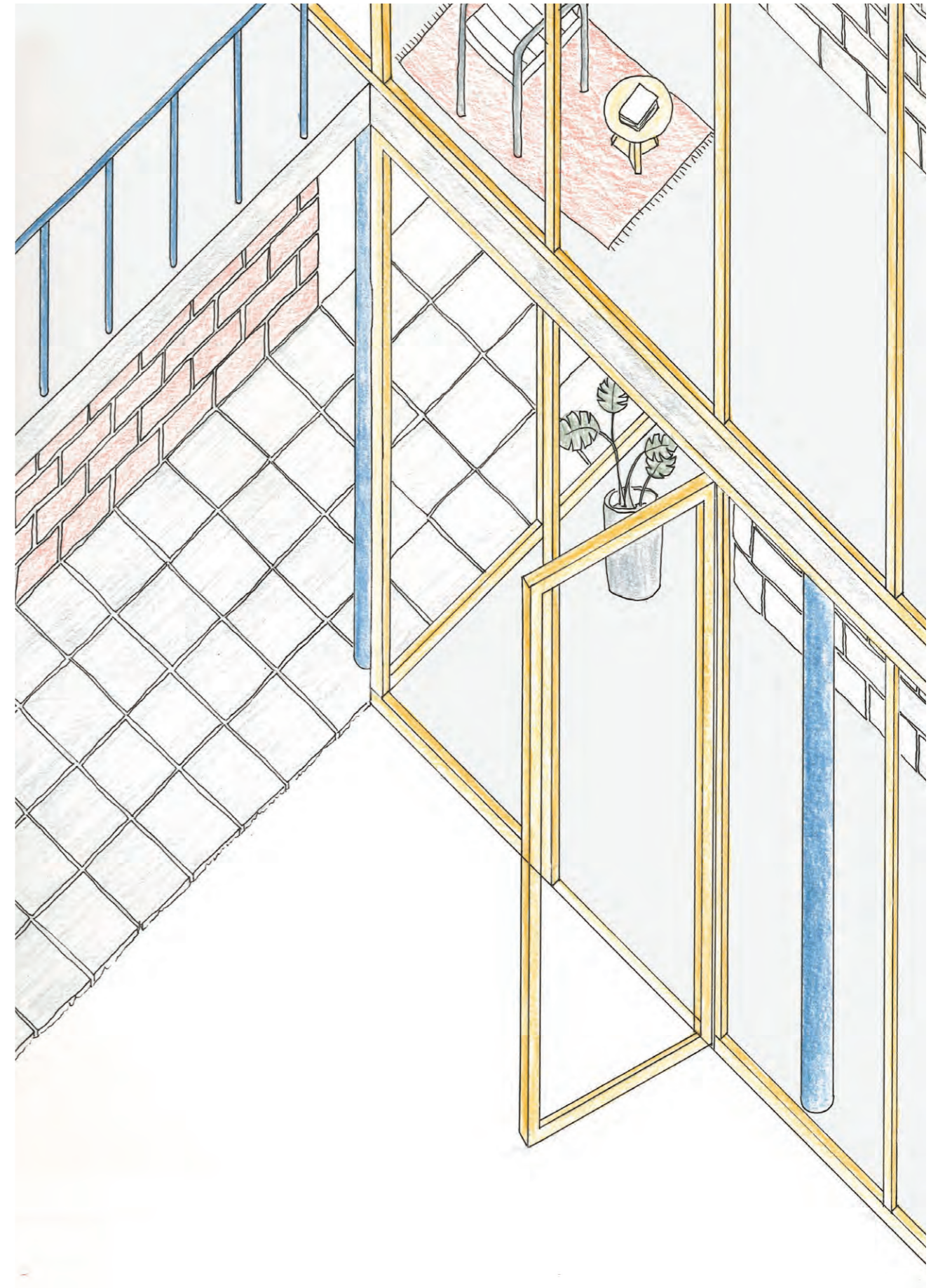
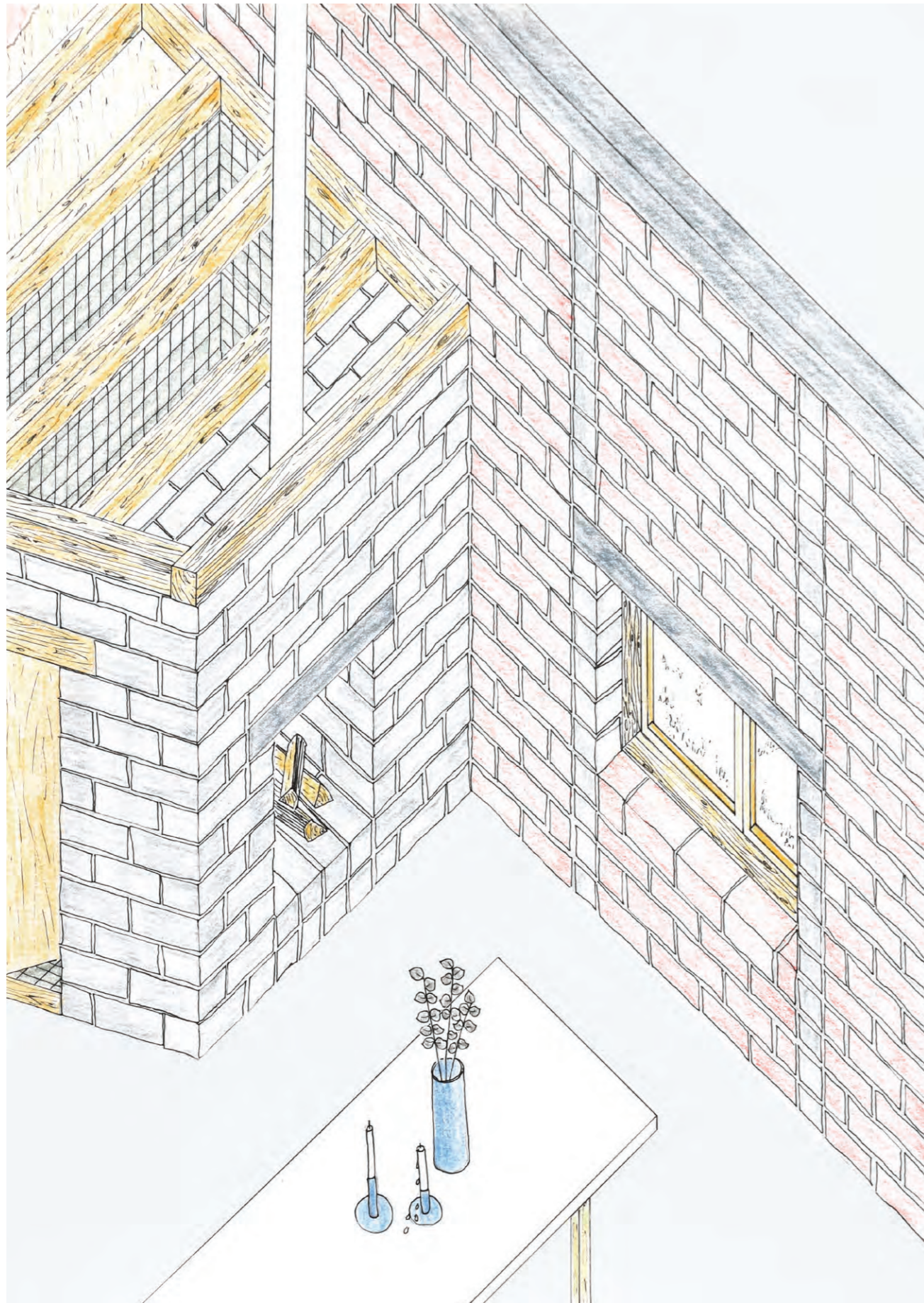

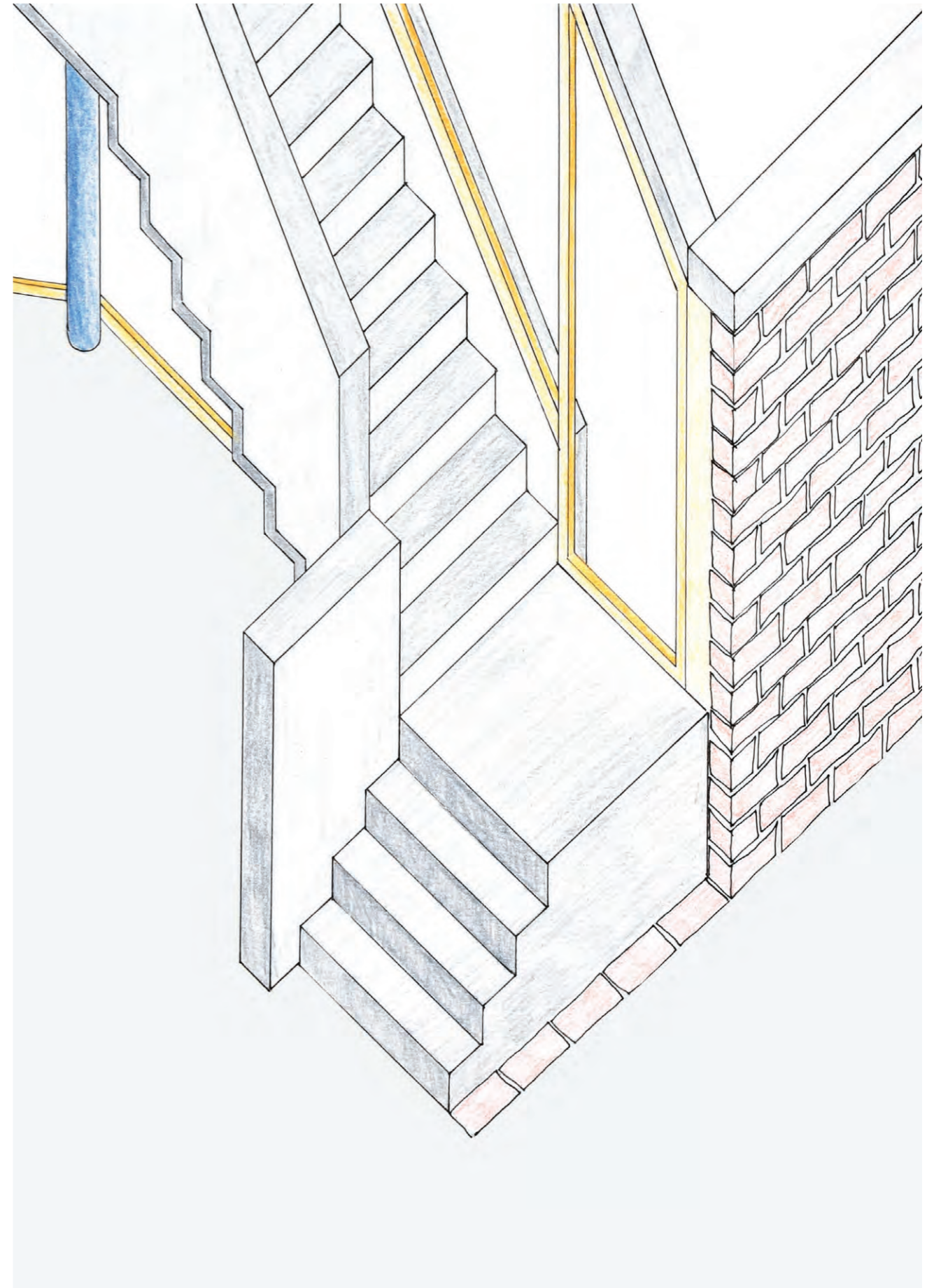
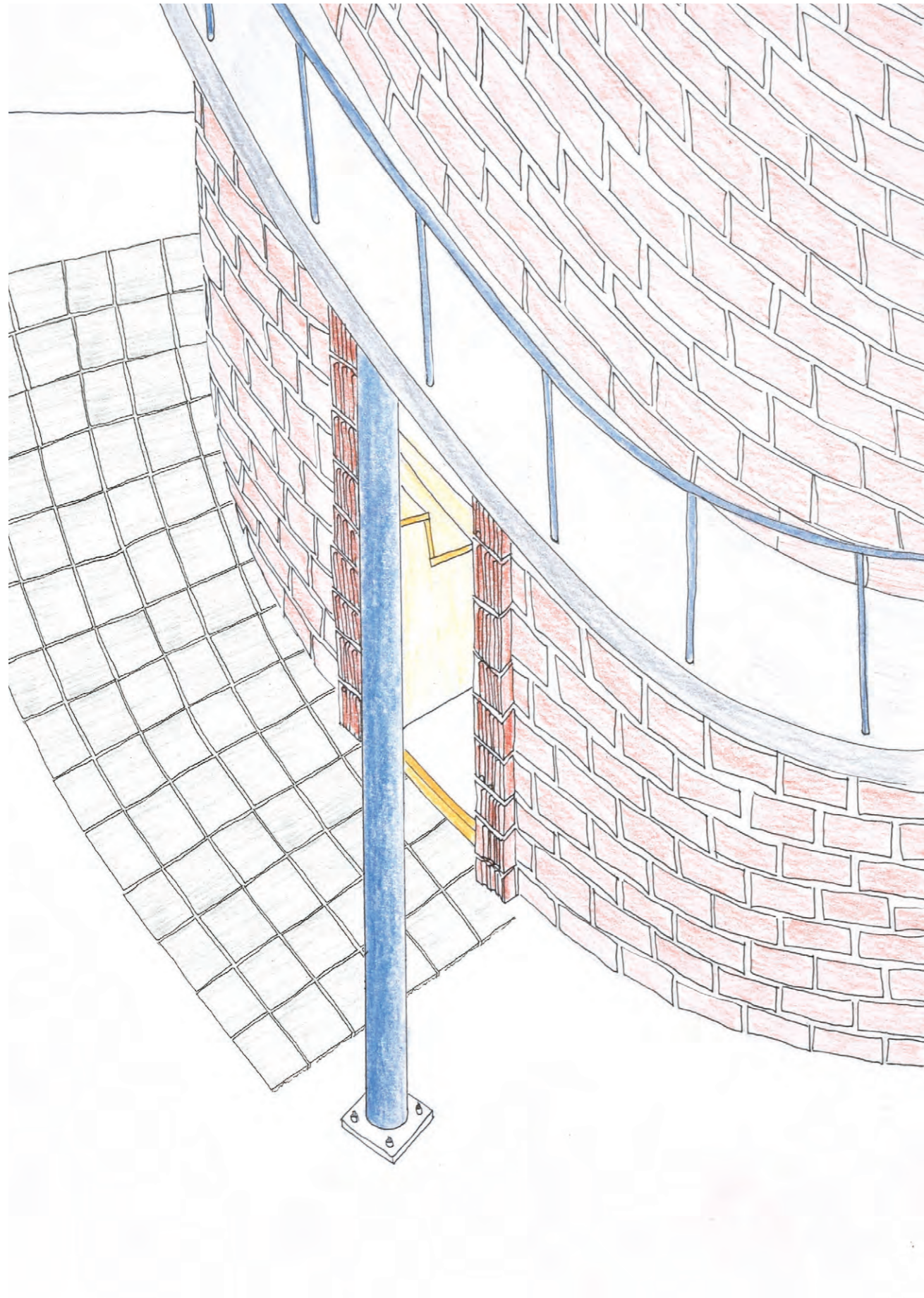

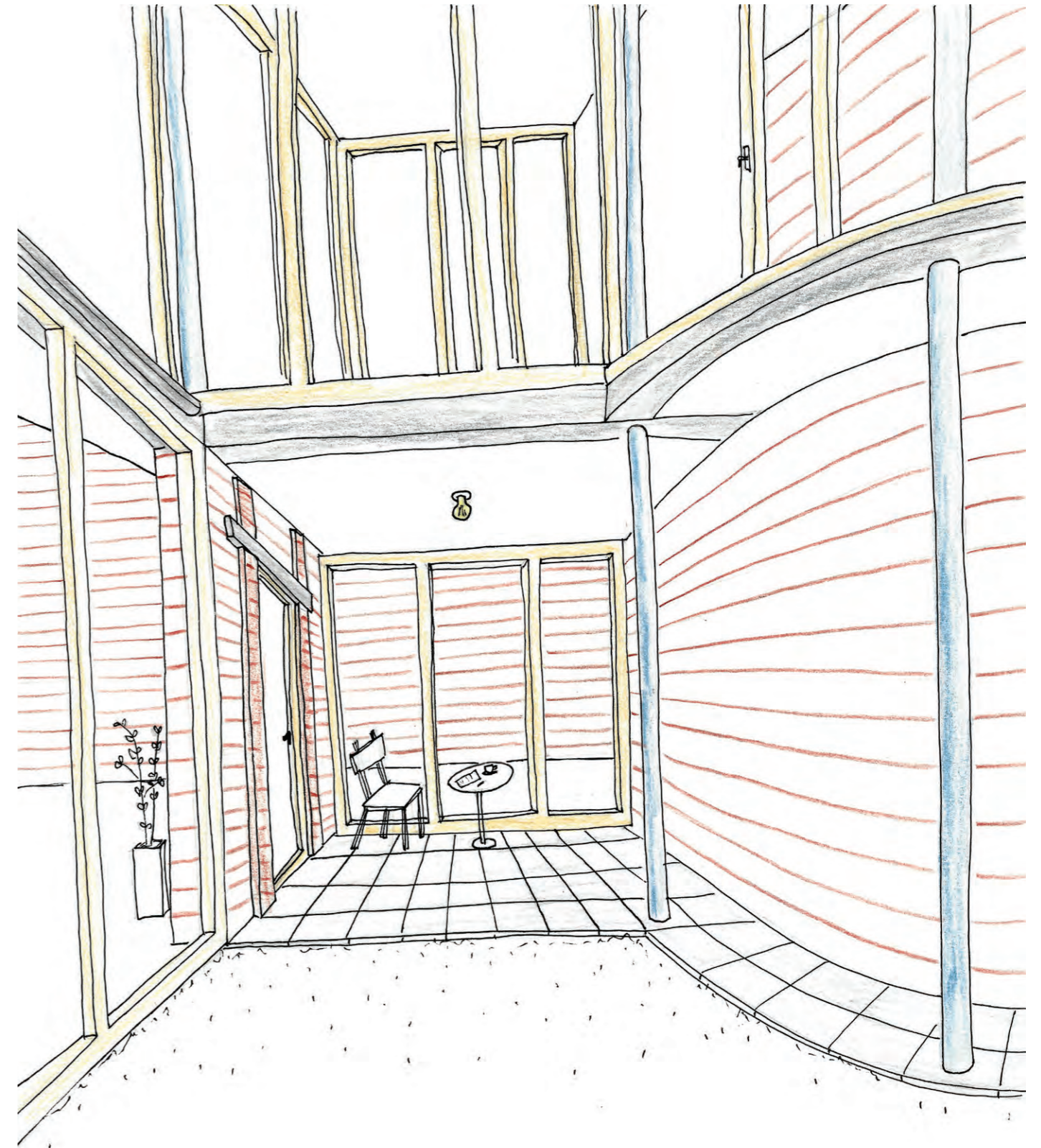
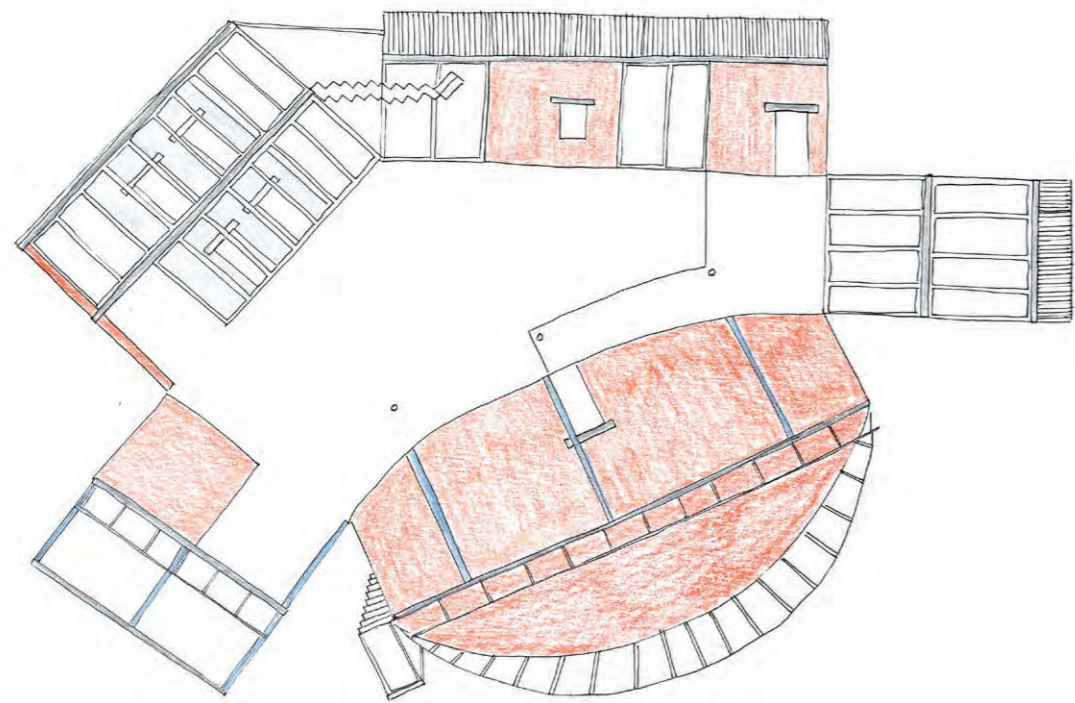

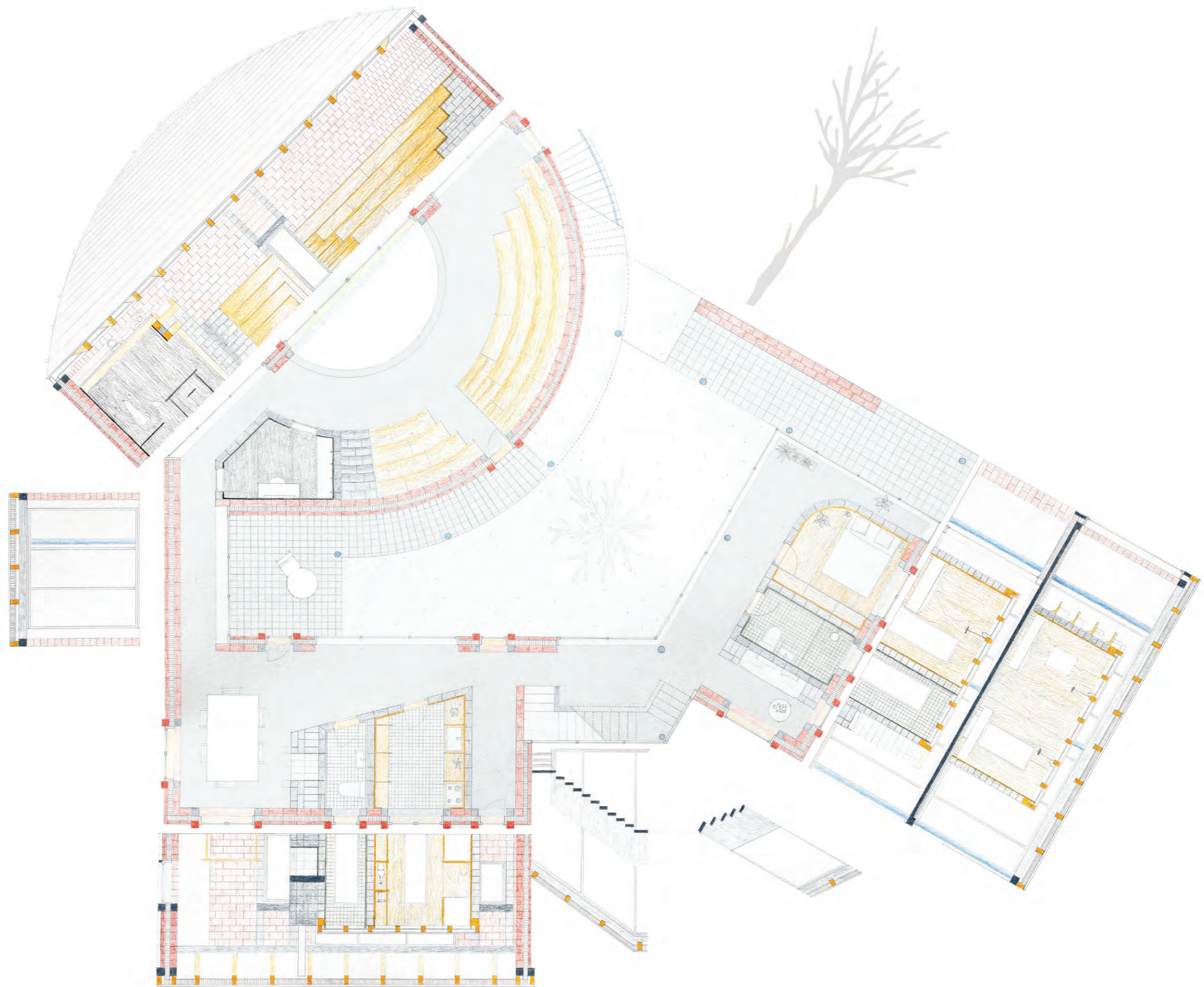

Dialogue

BE & CH in US

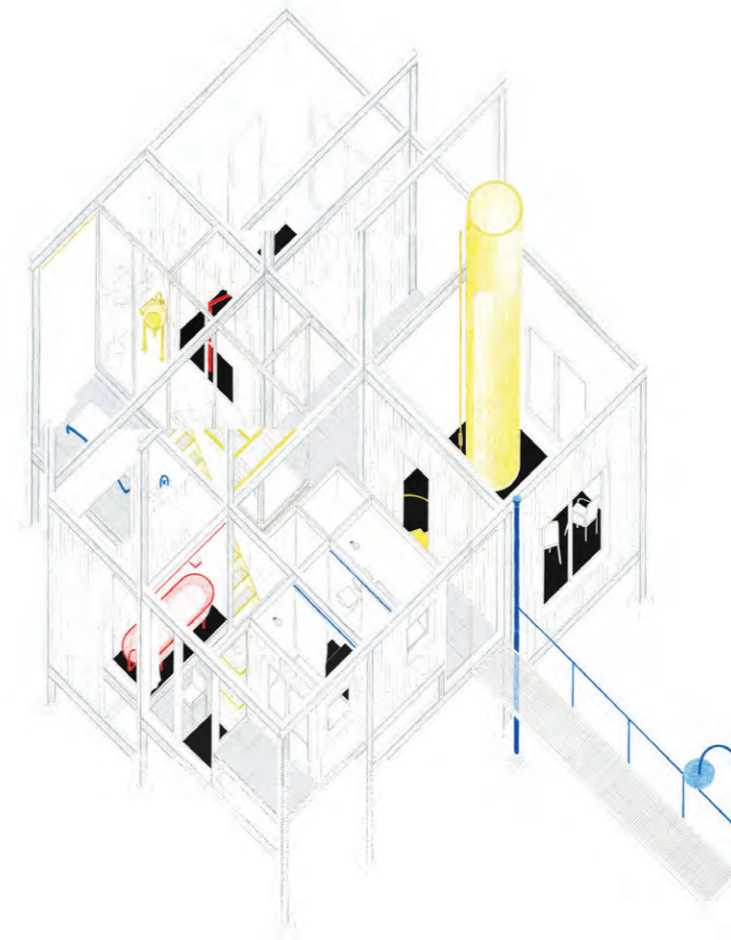
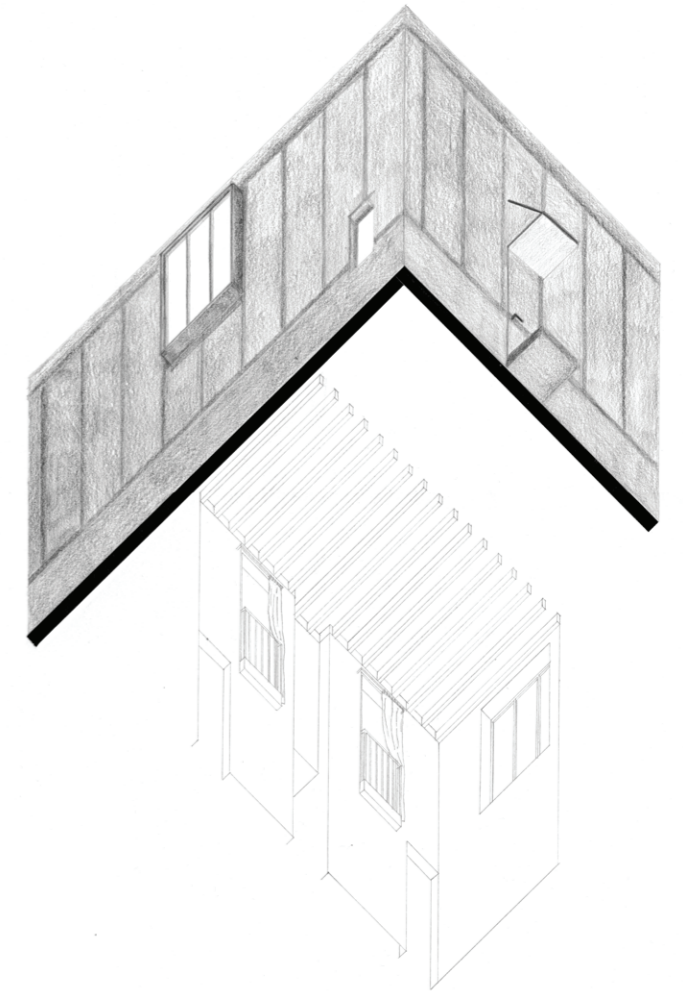
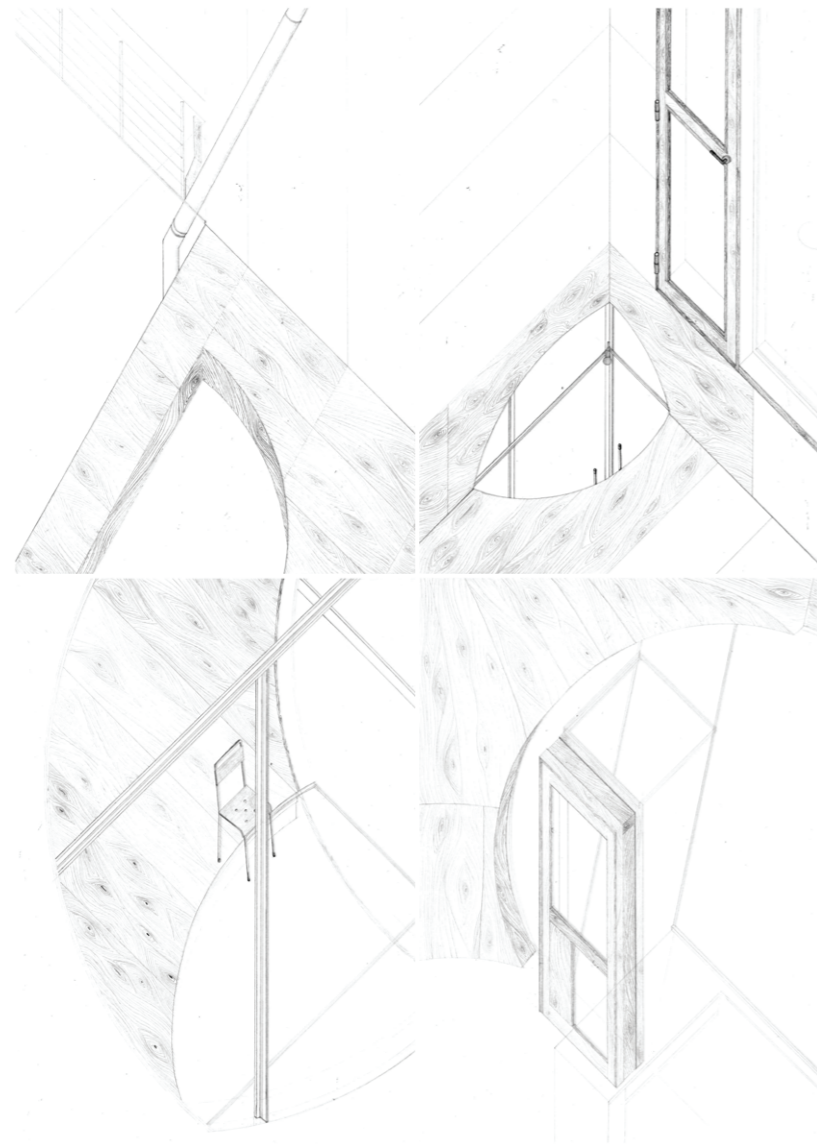

Dialogue

BE & US in CH

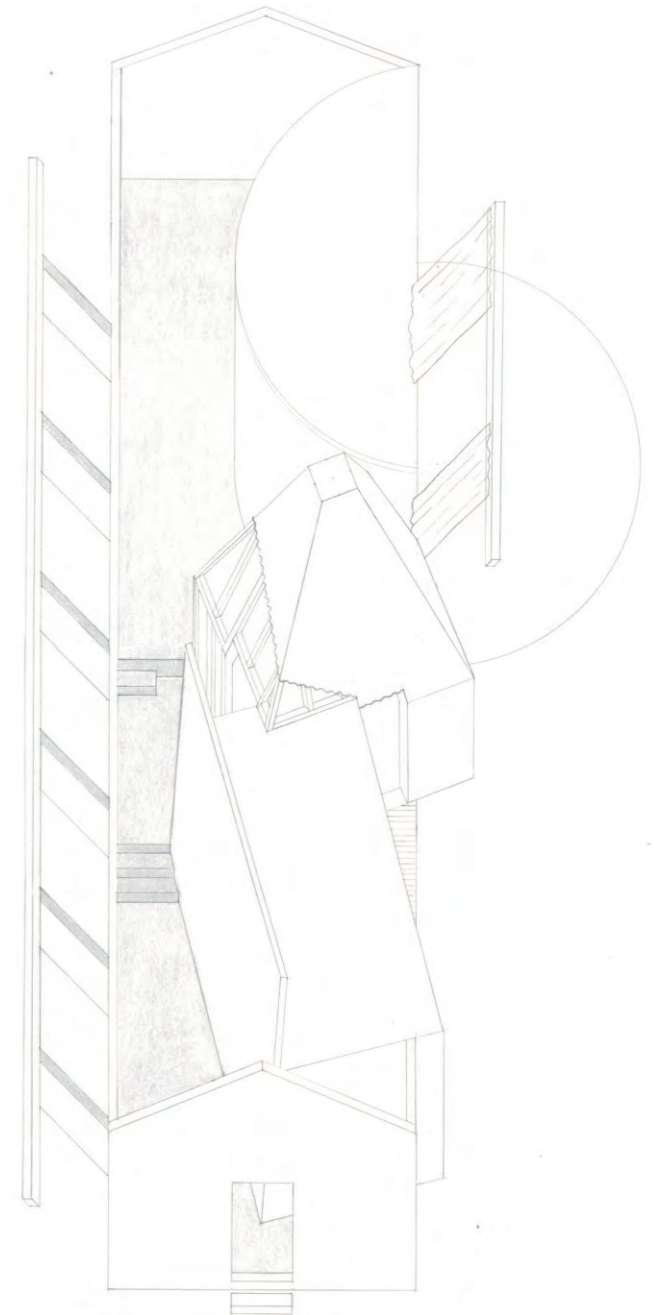
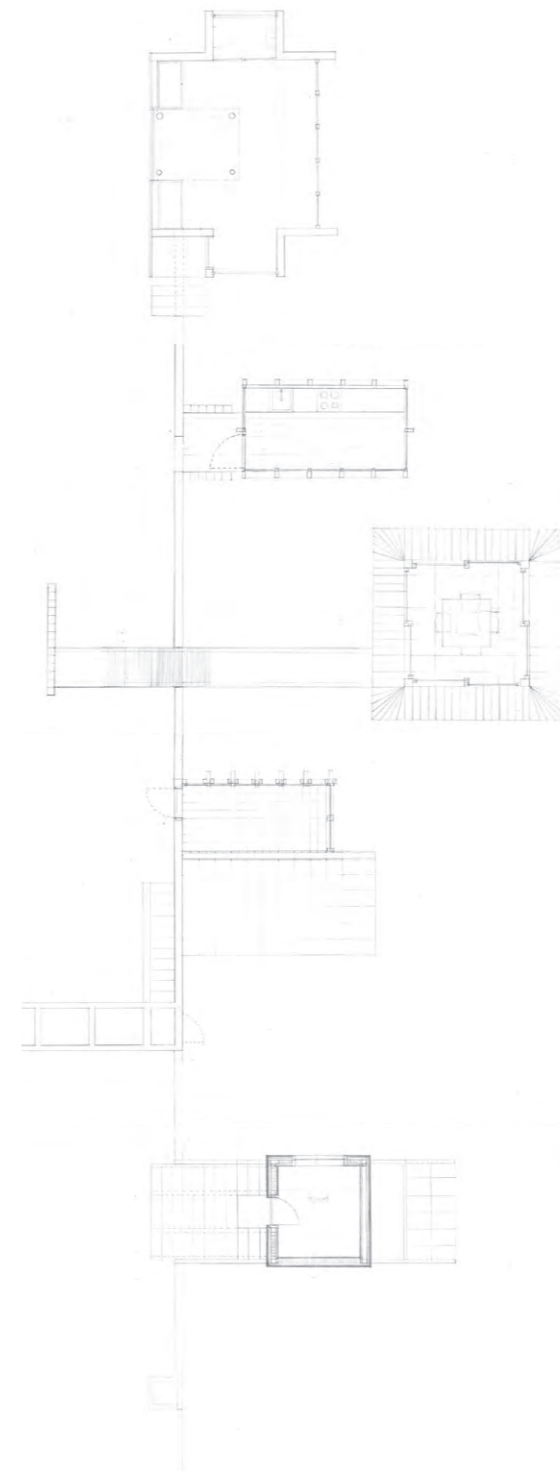
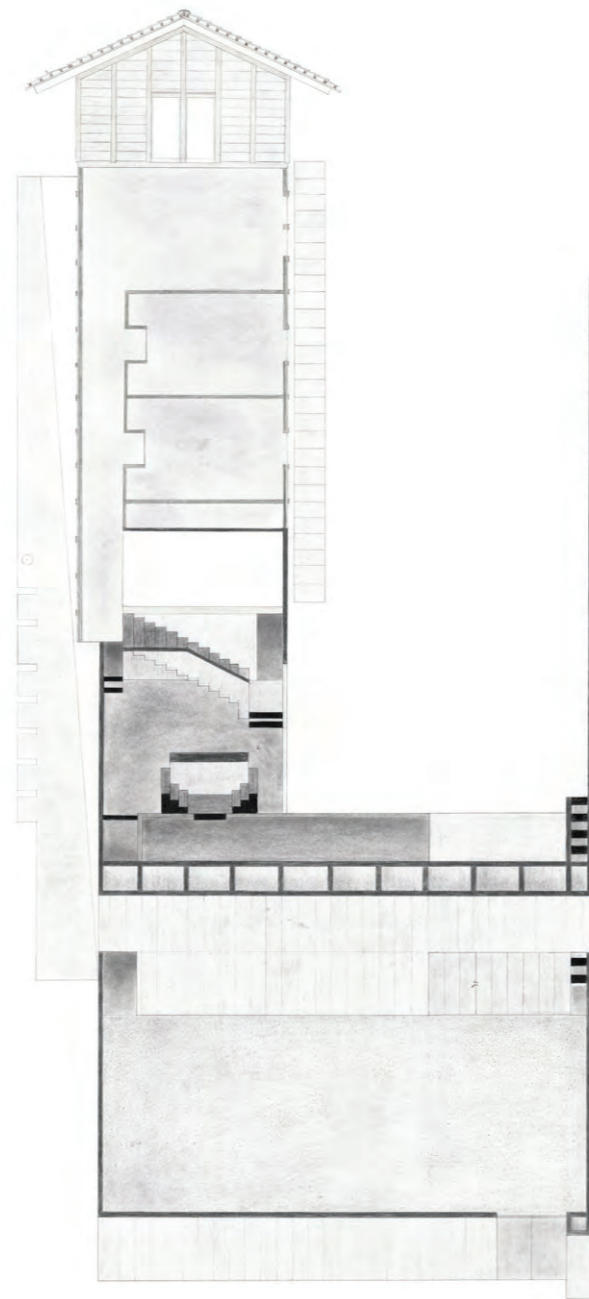

Dialogue

US & CH in BE



A

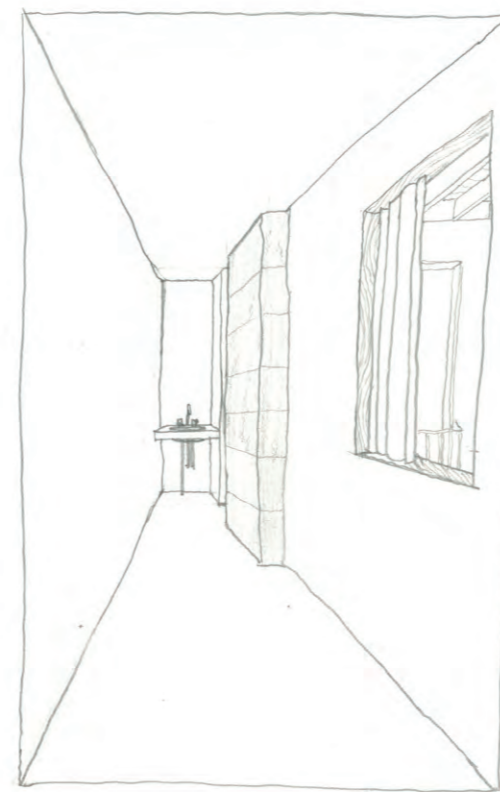
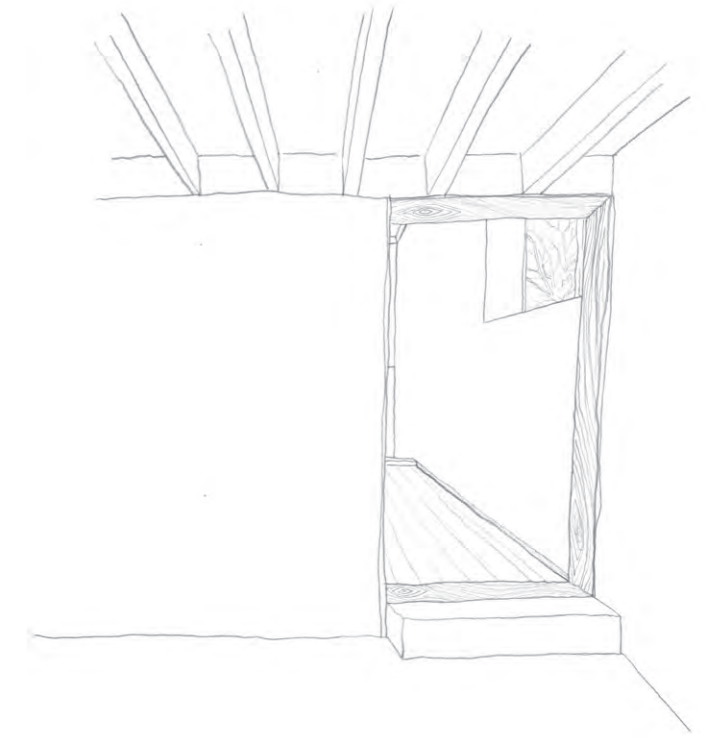
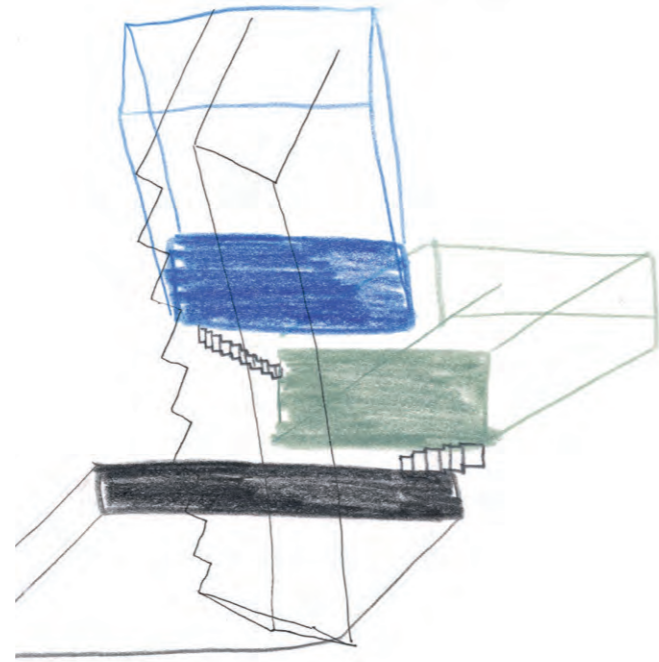

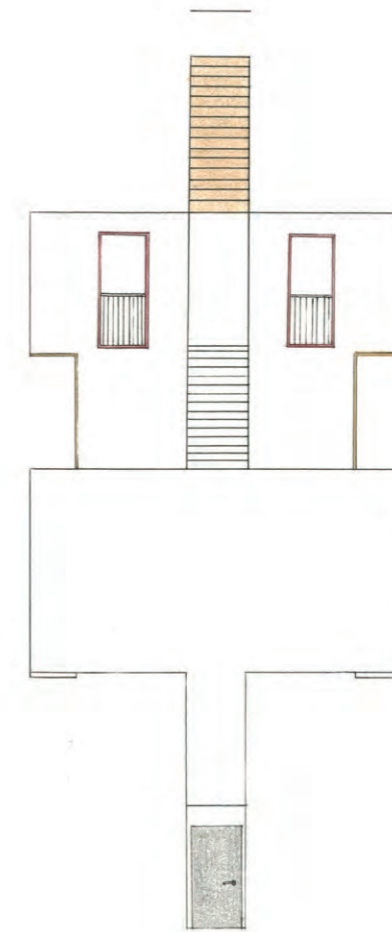
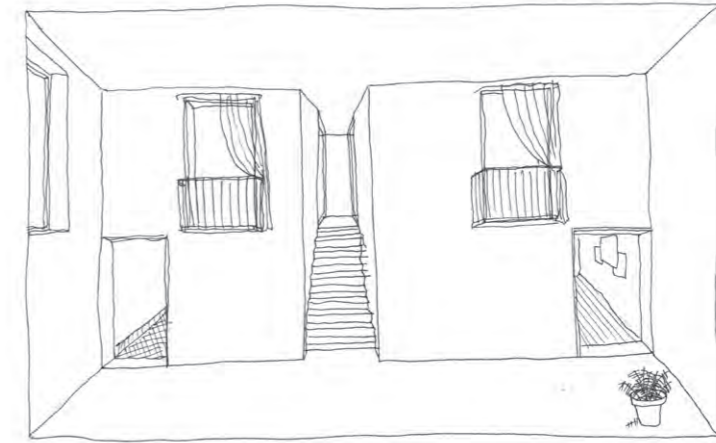
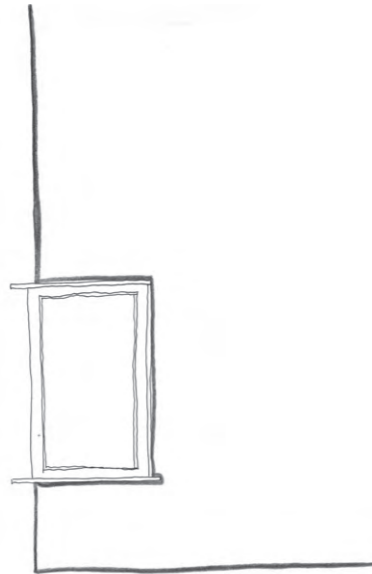
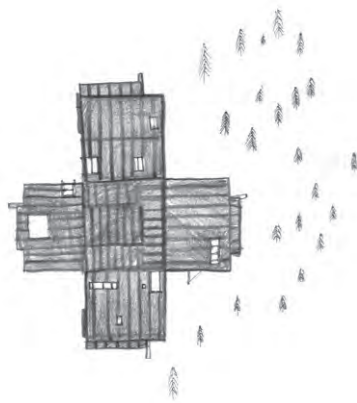
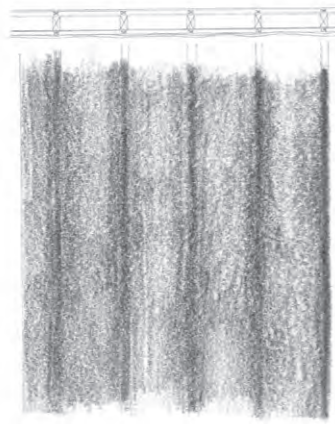
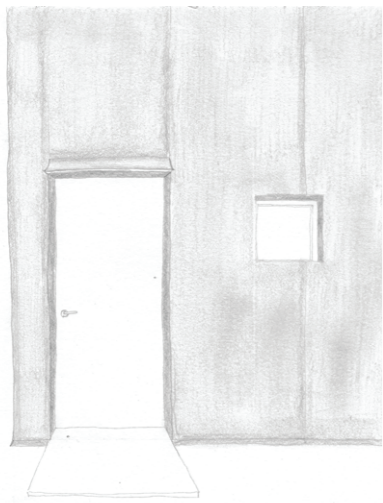

A

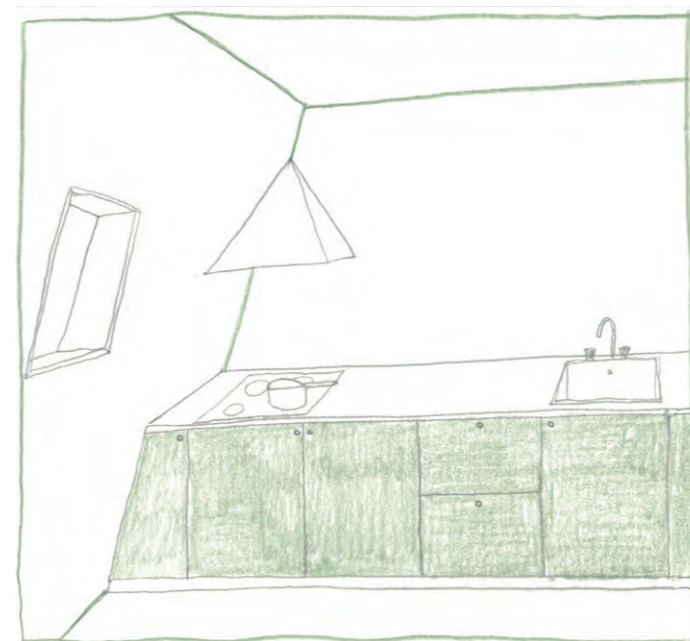
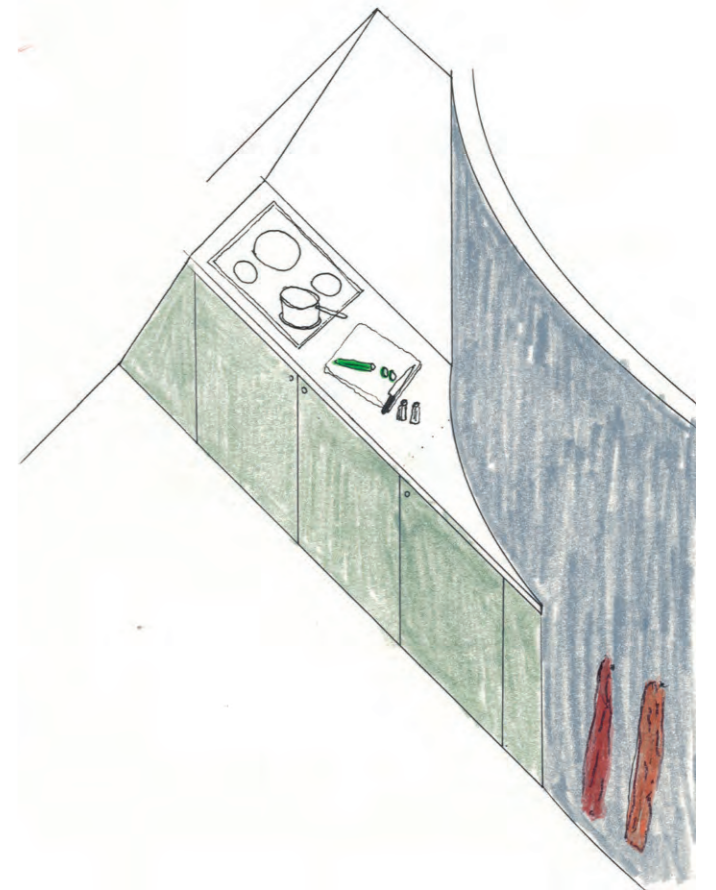
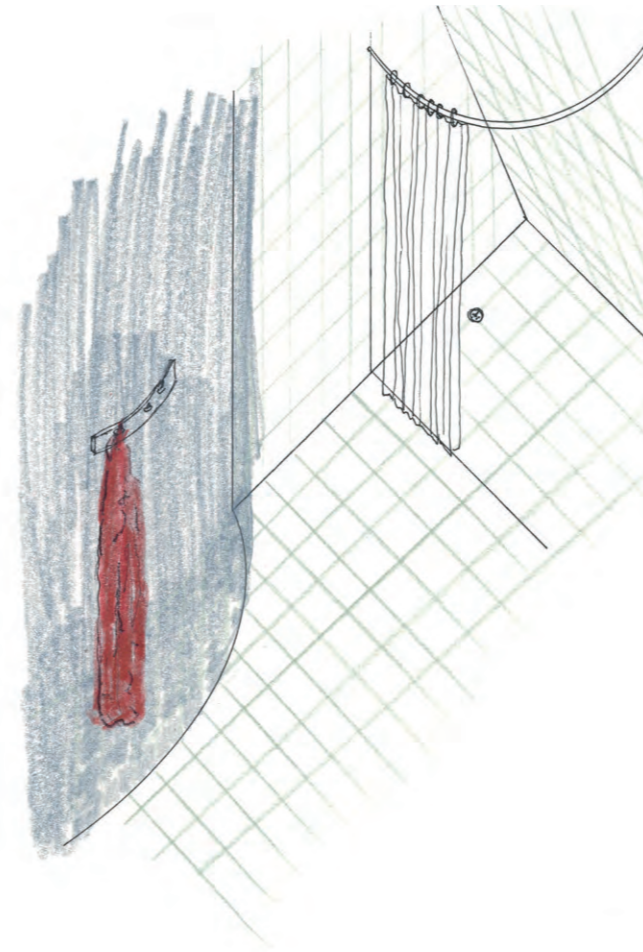
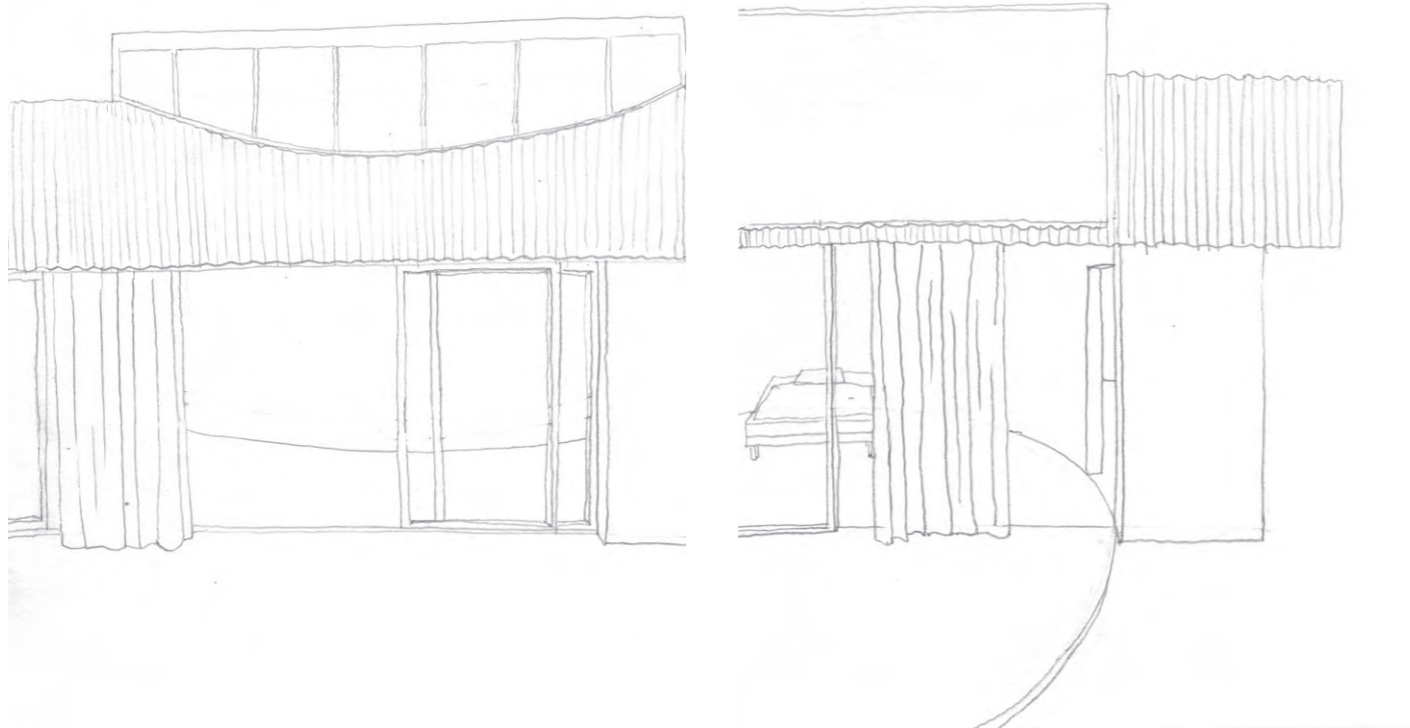

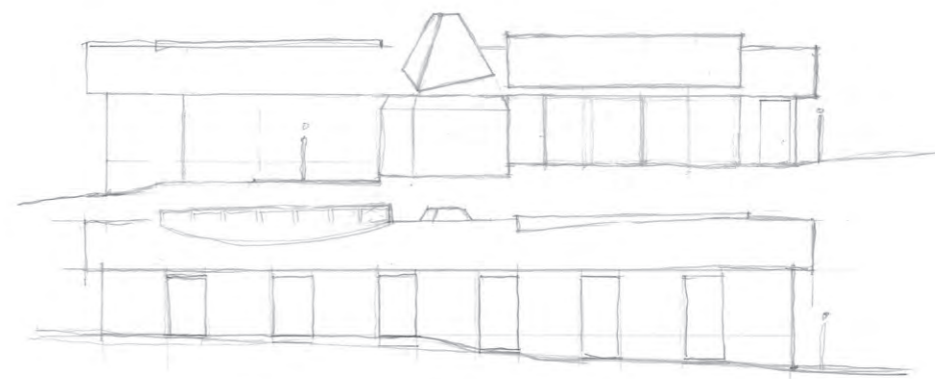
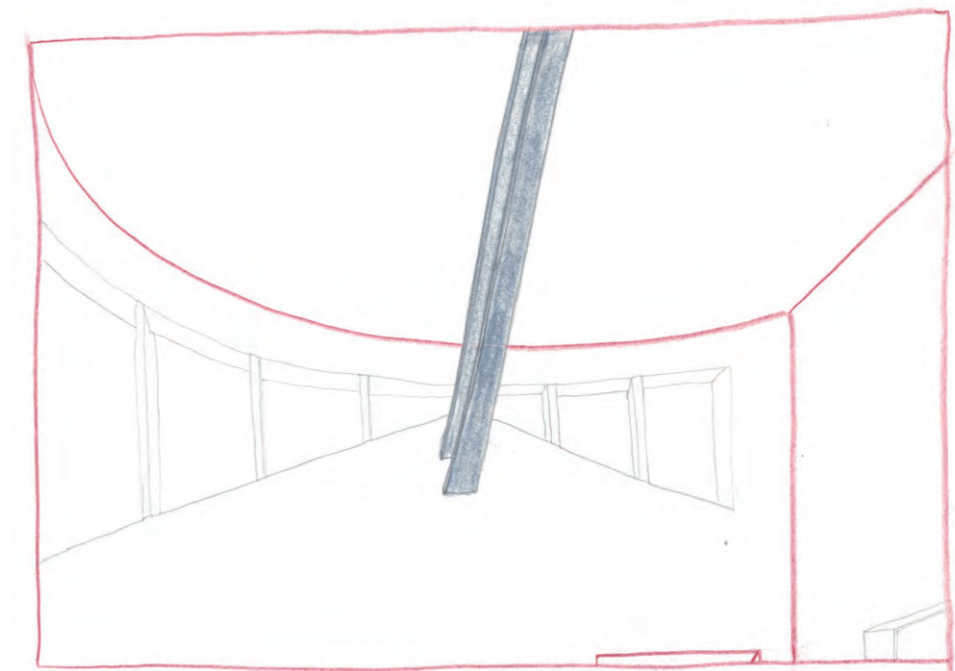
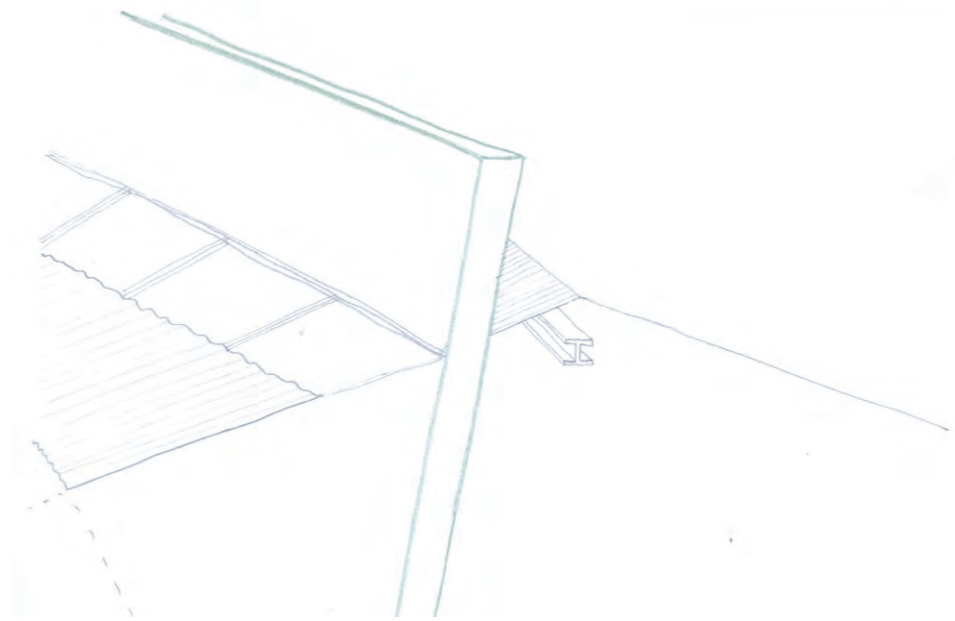
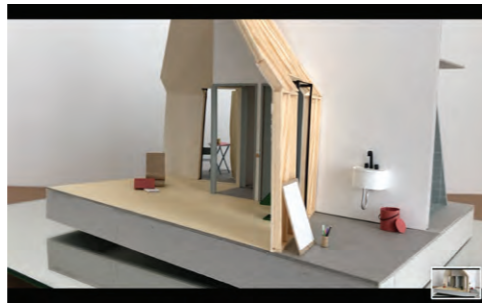

A

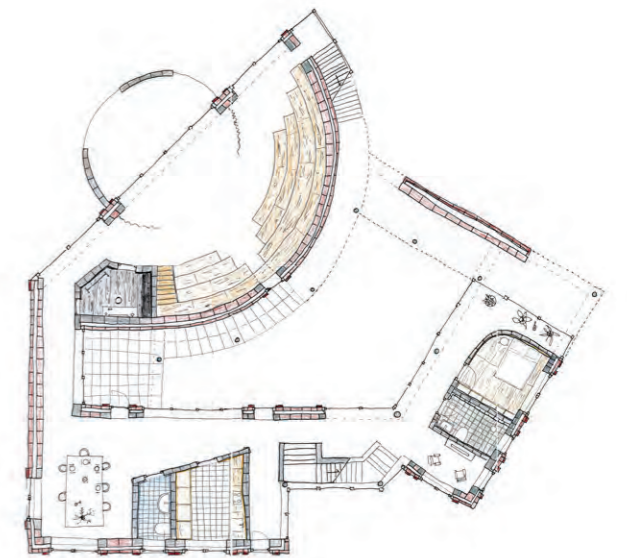
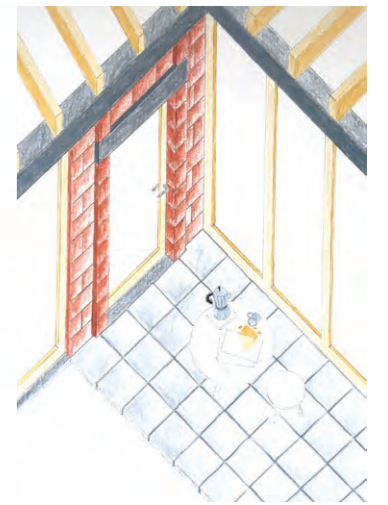
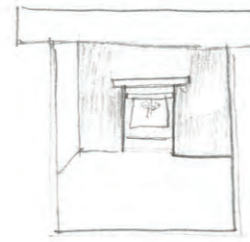
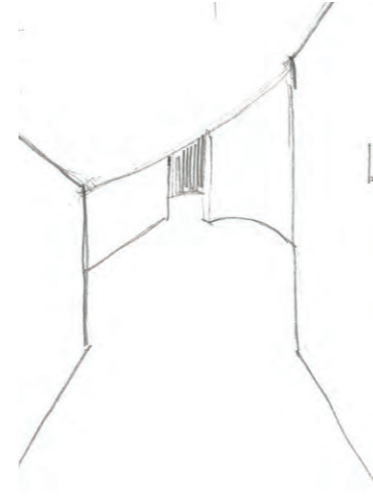
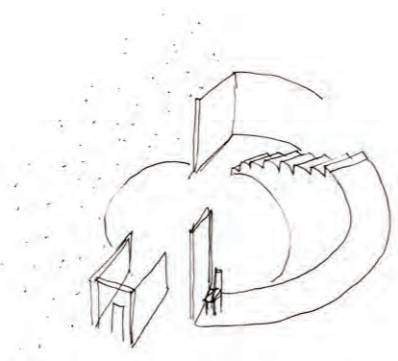

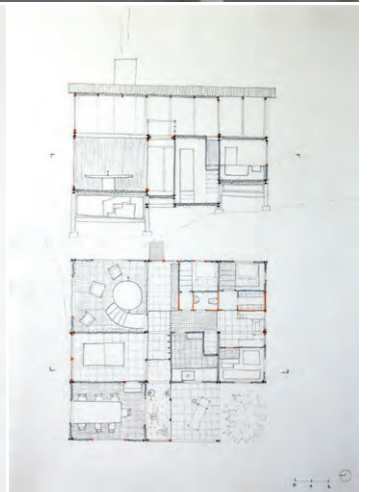
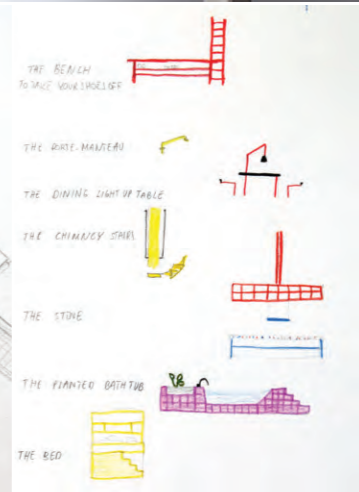
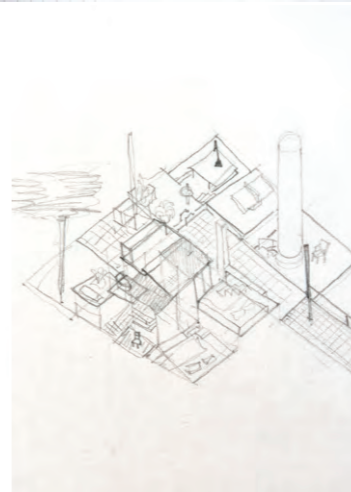
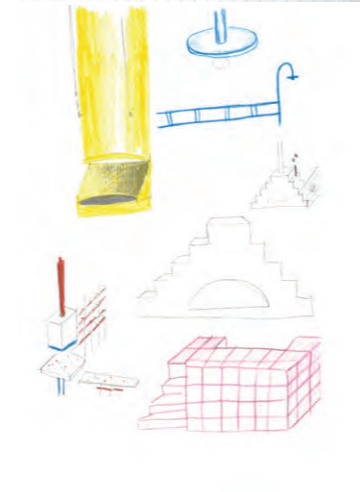
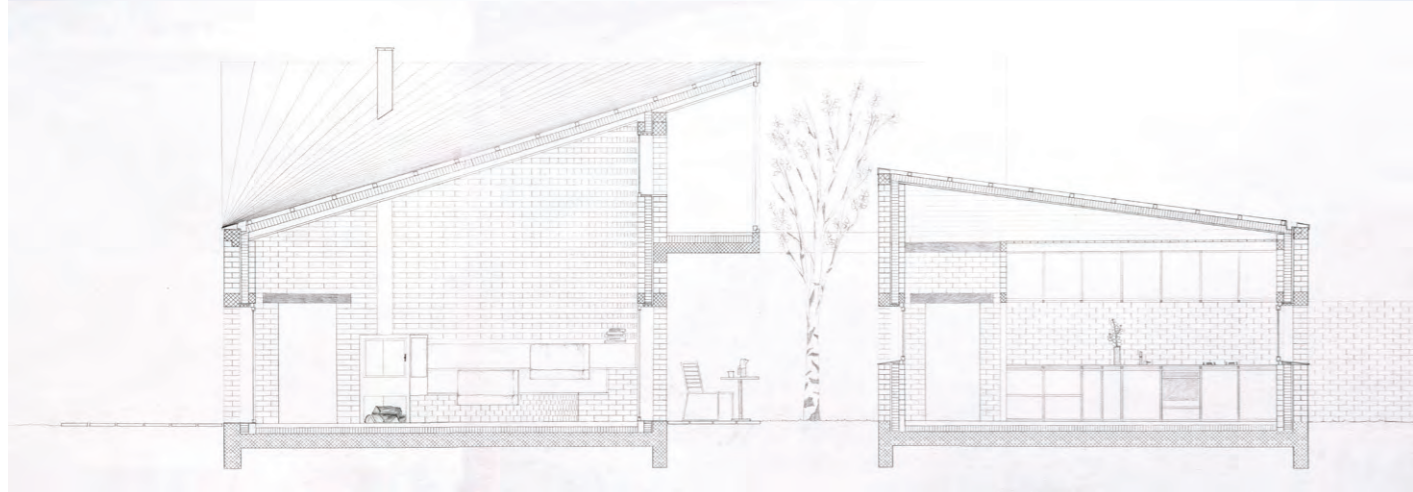
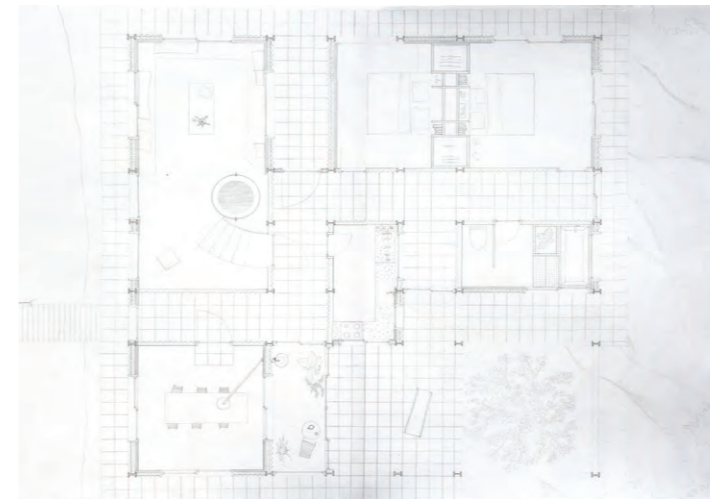
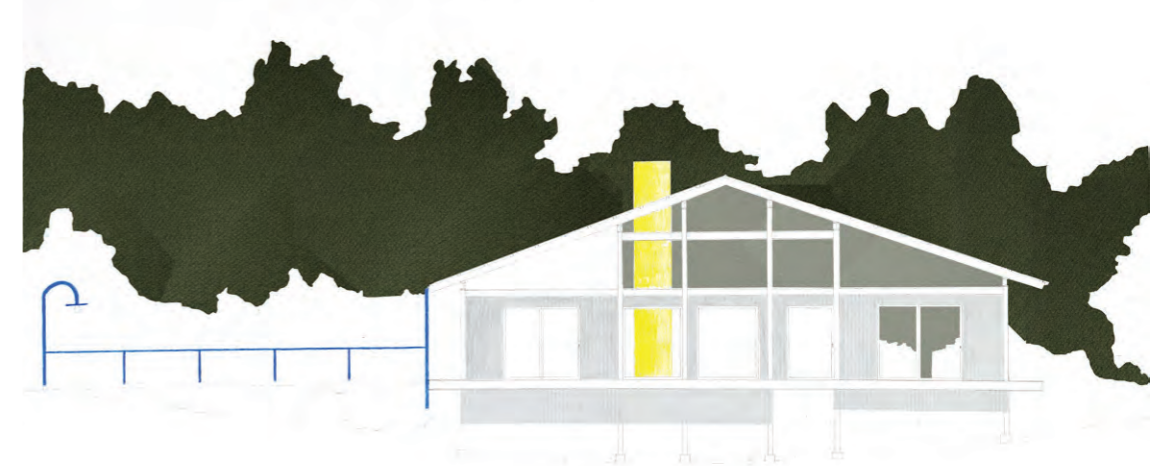
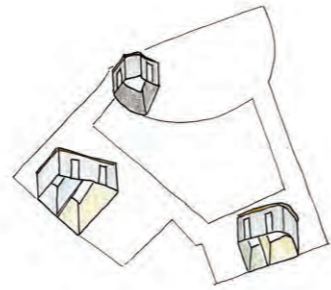
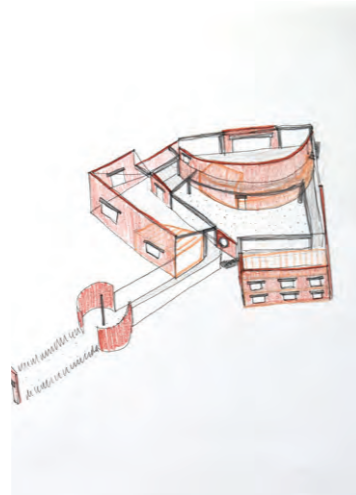
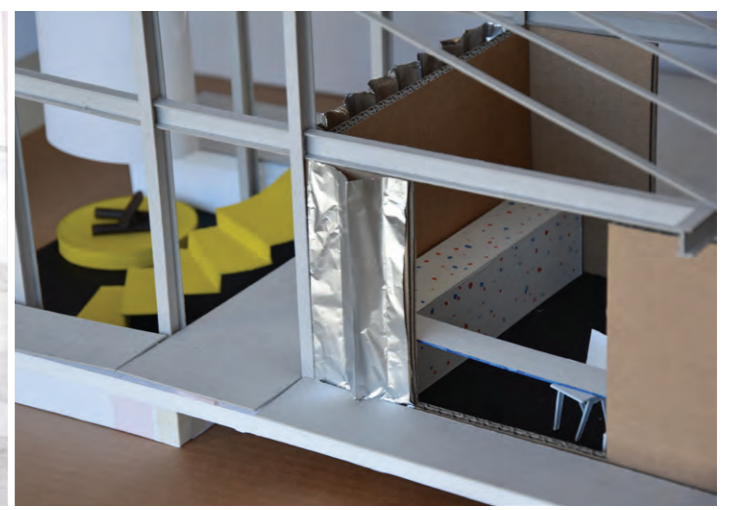
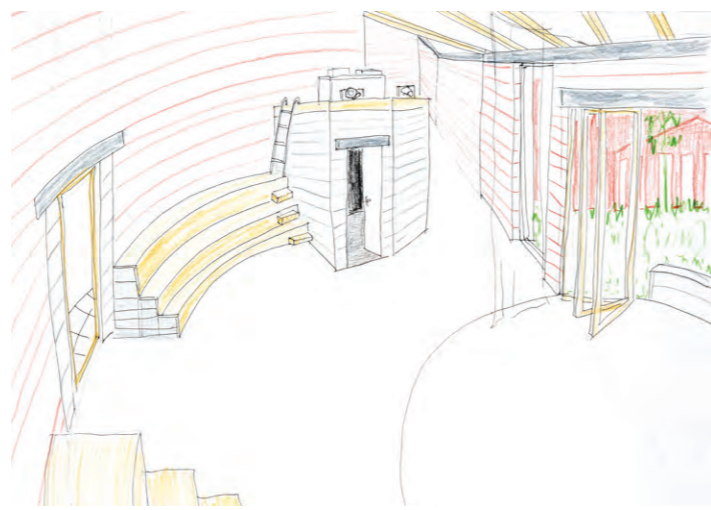
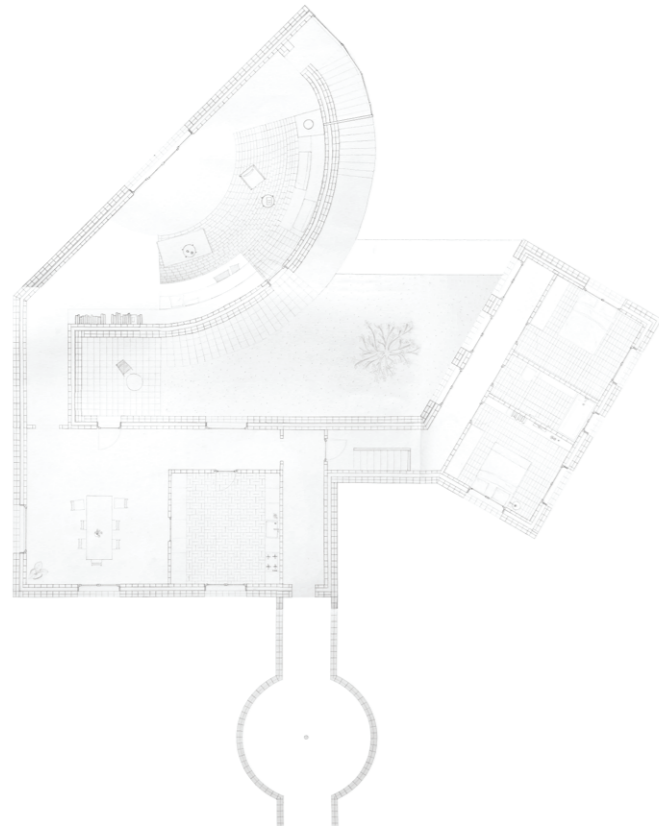

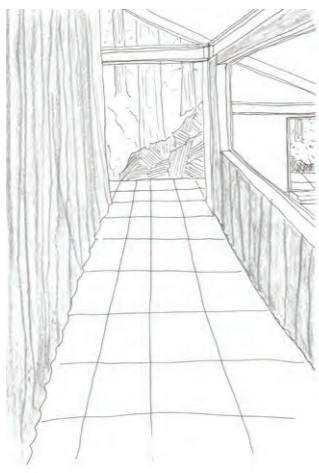
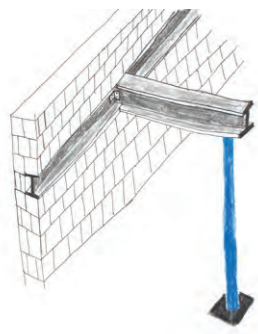

A

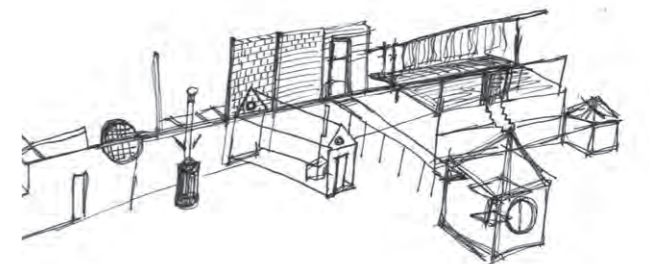
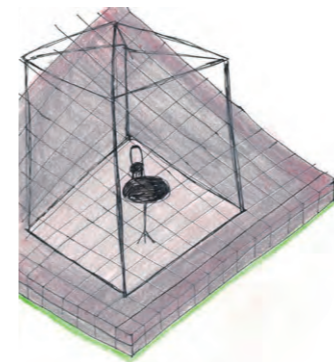
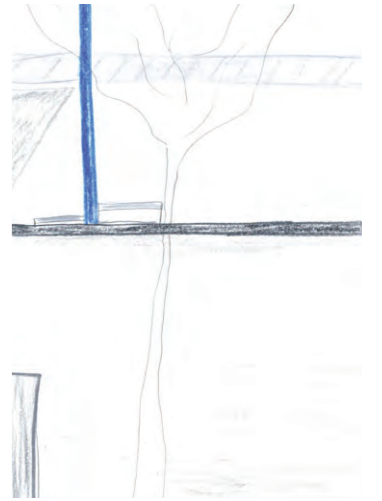
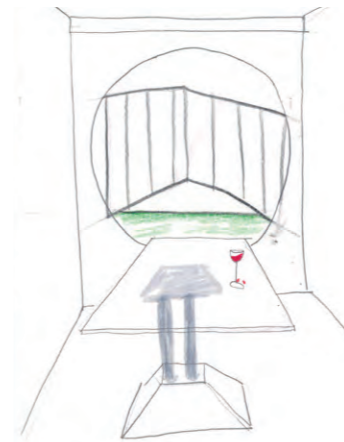
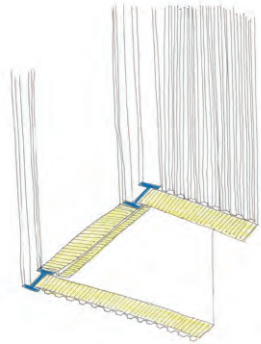
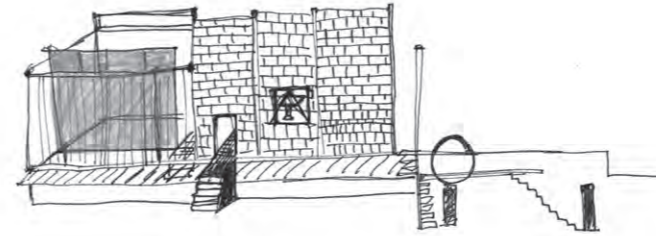
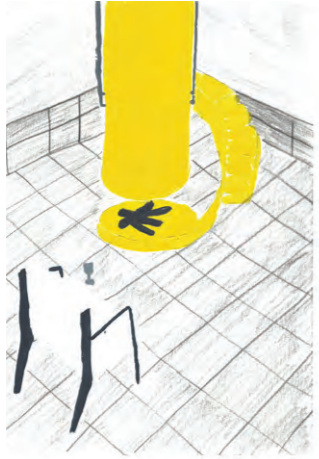

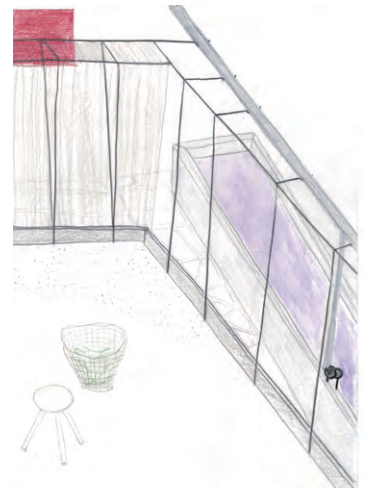
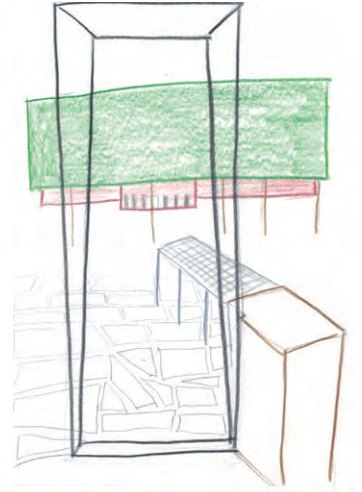
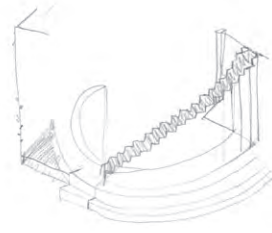
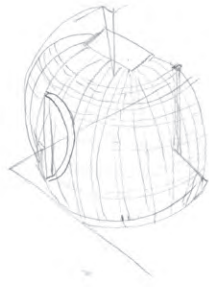
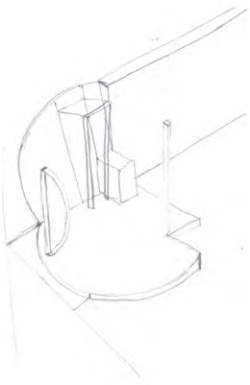

Hase, Natalie