

VOLUPTAS

MASTER THESIS SPRING 2020

DECLIVITAS

ARKO NAROYAN



“L’isolement est le meilleur moyen d’agir sur le moral des enfants; c’est là surtout que la voix de la religion, n’eût-elle jamais parlé à leur coeur, recouvre toute sa puissance d’émotion” said Edouard Ducpetiaux in 1843, at the dawn of the establishment of a new system of social punishment, abandoning all physical punishment in favour of more sober and discreet sentences, directed towards the deprivation of fundamental rights.

At that time, punishment was clearly focused on the need for repentance, on the redirecting of the penitent to God in order to find the right path. This formed the typology of confinement that we know today, largely inspired by that of the convent. Isolation, first of all with regard to society, but also internally, is established as a fundamental principle that allows one to rediscover a religious and therefore social reason.

Today, however, religion is no longer the central element of social organization. The foundations of contemporary society have in fact converged on issues that have more to do with globalization and omnipresent inter-connections, resulting in an environment marked by a constant frenzy. However, although it has evolved, the punitive justice system has not undergone a radical metamorphosis and today it seems out of step with the outside world to which it constantly refers.

The separative quality of the typology of the *milieu d’enfermement*, considered as a place of individual transformation that will restore to the State its lost subjects, still seems today to be in accordance with its role as a mirror of society. It is, however, the question of isolation within the structure itself that can be questioned, particularly in view of the constant hyper-connectivity of individuals in society. Through the question of isolation from society and inside of a macrocosm reflecting society, this project aims to question the role of an architectural typology in the materialization of societal phenomena such as the one described above.

I. ANALYSIS

Klybeck was historically the site of CIBA, the “Chemische Industrie Basel” company. Following a restructuring of the chemical-pharmaceutical industry and a change of ownership, the site is in a phase of typological change. Originally located on the outskirts of the city of Basel, on the border between Switzerland, France and Germany, downstream from the Rhin River, the city has gradually developed around the district. Because of the potentially dangerous activities carried out, the site remained closed to the public for almost a century, gradually becoming an enclave within the city. This area of land is characterized by the strong presence of different types of thresholds close to each other, thus becoming the main specificity and quality of the site. Its planned opening gives the opportunity to requestion its role in the city of Basel, its qualities and its potentials.



switzerland
AERIAL VIEW
DECLIVITAS

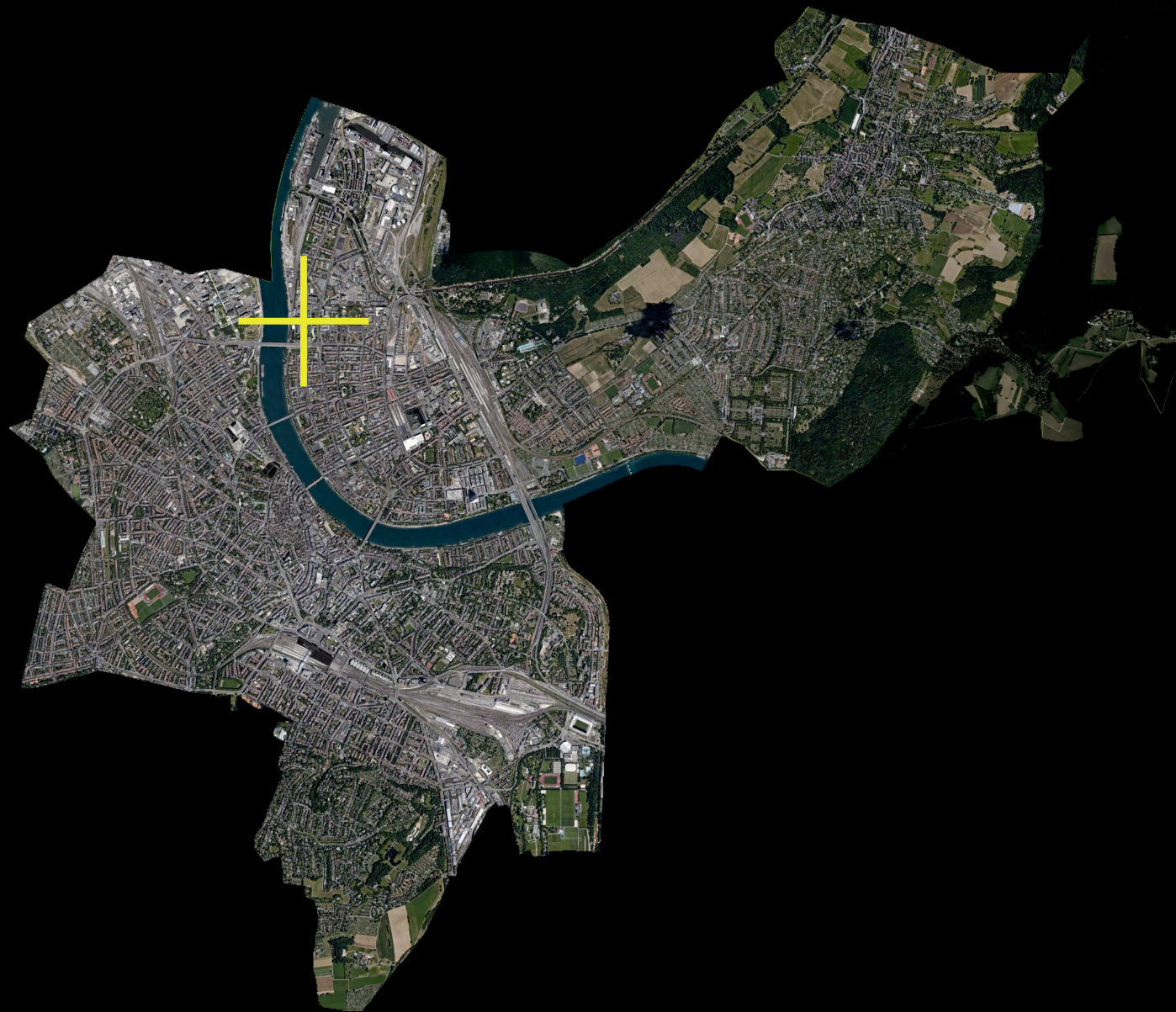

basel-stadt canton

AERIAL VIEW

DECLIVITAS



city of basel
AERIAL VIEW
DECLIVITAS



klybeck
AERIAL VIEW
DECLIVITAS



national borders
AERIAL VIEW
DECLIVITAS



rhine river
AERIAL VIEW
DECLIVITAS

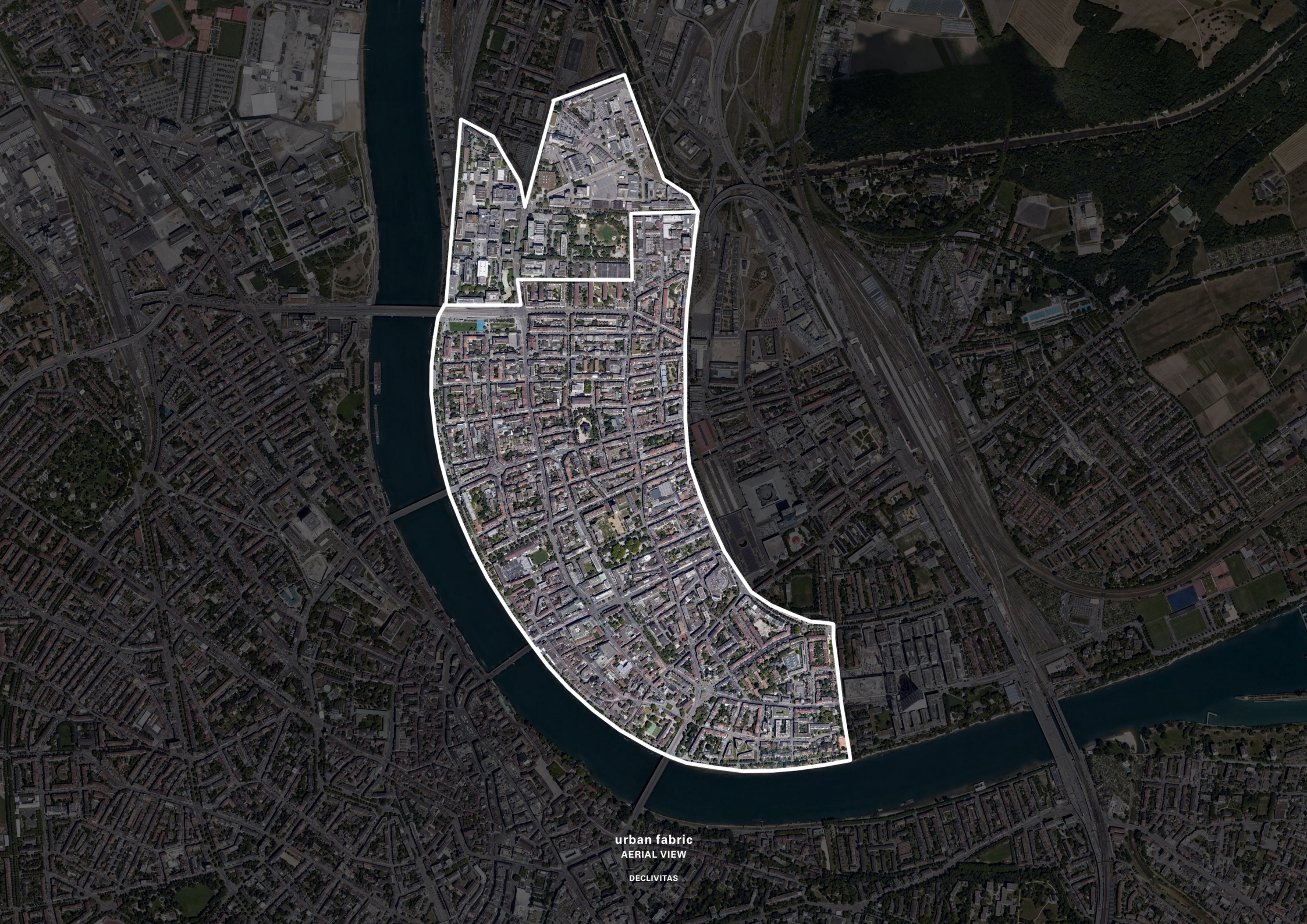

urban fabric
AERIAL VIEW
DECLIVITAS

The presence of many large-scale buildings in good condition on the site makes it interesting to consider a transformation and renovation of the neighborhood rather than a destruction and reconstruction. Because of their imposing size, most of them call for big programs. Moreover, the integration of the area as an integral part of the functioning of the city brings the social question to the front. As such, it seems important to turn towards the direct needs of the city in terms of large-scale social infrastructure.



ex-ciba campus
AERIAL VIEW

DECLIVITAS



ex-ciba campus
SITUATION PLAN

DECLIVITAS



industry
SITUATION PLAN

DECLIVITAS



infrastructure
SITUATION PLAN

DECLIVITAS



housing
SITUATION PLAN

DECLIVITAS



basel city
BIRD'S EYE VIEW

DECLIVITAS



ex-ciba campus
BIRD'S EYE VIEW

DECLIVITAS



ex-ciba campus
BIRD'S EYE VIEW

DECLIVITAS



ex-ciba campus
BIRD'S EYE VIEW

DECLIVITAS



ex-ciba campus
HISTORICAL PHOTOGRAPH

DECLIVITAS

“At the other end of the city, Roche is more strongly preserving its industrial character; this area is also being reshaped with spectacular buildings.”

Basel recently announced a shortage of forty prison places and a project to extend a prison center near Klybeck in order to make up the deficit. However, it seems that the restructuring of the old industrial site gives the opportunity to imagine a relocation of the prison center in its core by colonizing an existing building carcass. At the same time, it makes possible to propose an alternative to classical prison typology and answer the most recent needs.

The city of Basel currently has three prisons, one of which is mixed, for 111 prisons throughout Switzerland, mainly in the north-west of the country, where the density is the highest and where the major cities are located. The number of prison places is relatively high: 7,324 places for 8,500,000 inhabitants, i.e. one place for about 1,160 inhabitants. Despite the seemingly high ratio, the country is currently facing a phenomenon of prison overcrowding due to an exponential growth in the number of prisoners over the last thirty years. Although the curve currently tends to decrease and flatten, the shortage is still urgent. Moreover, beyond the concrete question of overcrowding, the prison system is currently undergoing many challenges due to rapid changes of the structure of society in general.

SWISS PRISON'S STATISTICS

permanent resident population	8'542'323
total amount of inmates	6'943
of which men	6'547
of which women	396
total amount of detention places	7'394
rate per 100,000 swiss permanent residents	
inmates	81
dentetion places	87



swiss prisons
MAP

DECLIVITAS

BASEL-STADT CANTON PRISON'S STATISTICS

Bässlergut site	
total places	73
for men	73
for women	-
for minors	-
workplaces	26.5
Untersuchungsgefängnis Basel-Stadt site	
total places	148
for men	117
for women	18
for minors	13
workplaces	56
Vollzugszentrum Klosterifichten site	
total places	22
for men	22
for women	-
for minors	-
workplaces	15.7



BÄSSLERGUT

UNTERSÜCHUNGSGEFÄNGNIS

VOLLZUGSZENTRUM

prisons
MAP

DECLIVITAS



BRENTAG

NOVARTIS

BAU 125

MESSETURM

ROCHETOWER

LONZA TOWER

GRASPETER TOWER

towers
MAP

DECLIVITAS

Les prisons suisses à la limite de leurs capacités

Par Gaby Ochsenbein



La surpopulation carcérale pèse sur le moral des gardiens et des détenus.

(Ex-press)

En Suisse, les pénitenciers sont pleins à craquer. Plus de 300 prisonniers sont maintenus plus longtemps que nécessaire dans des prisons régionales préventives comme celle de Berne, où leur situation est précaire.

actual situation

STATISTICS

DECLIVITAS

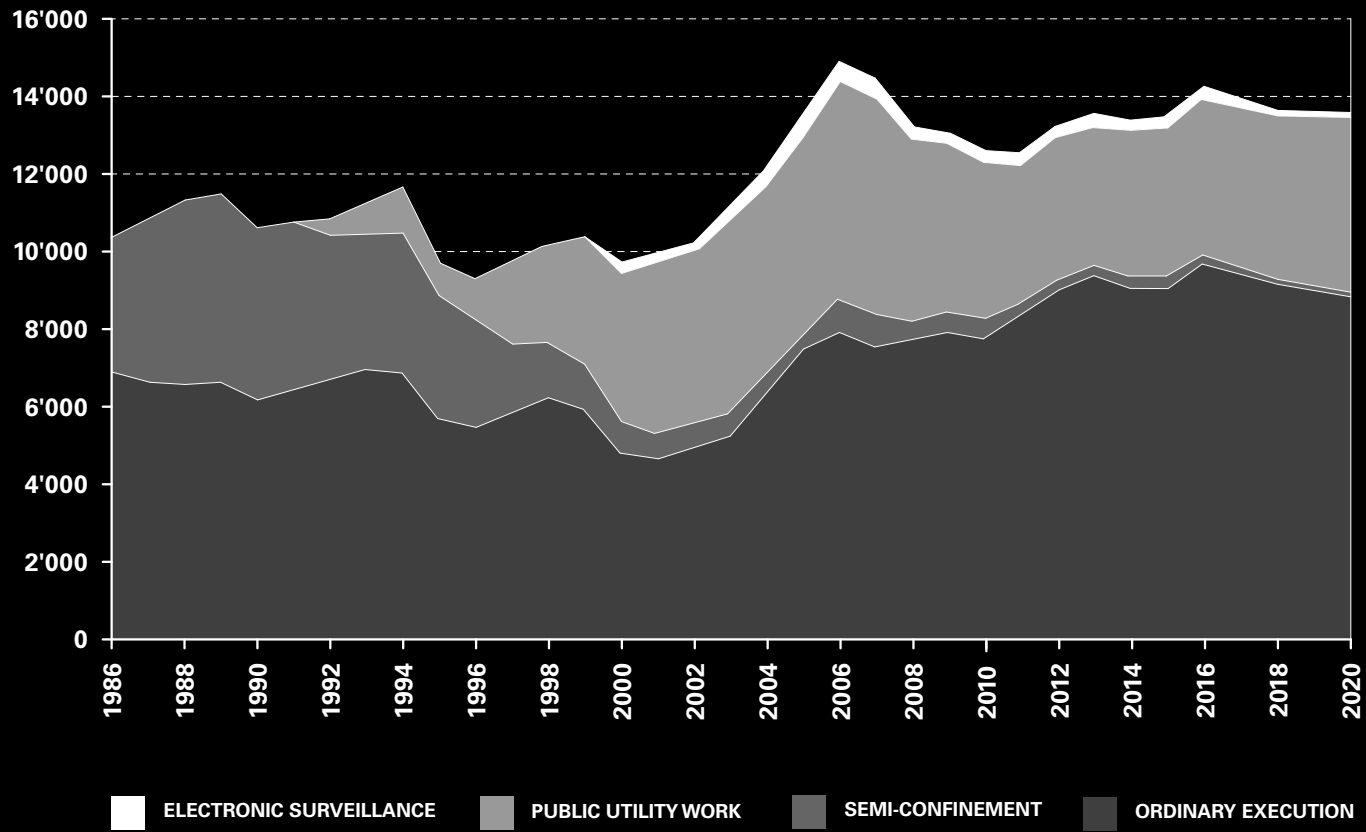

II. INTENTIONS

Taking as valid that imprisonment is the answer to certain types of transgressions of the law and therefore without questioning the whole judicial system, the project still aims to give an alternative and new vision regarding social isolation as punishment and focus rather on the aspect of re-learning. Being an enclosed environment, the project stands as a heterotopia of deviation, proposing a macrocosm mirroring society, in a protected environment. Today's society is shifting more and more towards a society of leisure, the emphasis is set on common life and social interactions rather than isolation and individualization.

“What was at issue was not whether the prison environment was too harsh or too aseptic, too primitive or too efficient, but its very materiality as an instrument and vector of power; it is this whole technology of power over the body that the technology of the ‘soul’ — that of the educators, psychologists and psychiatrists — fails either to conceal or to compensate, for the simple reason that it is one of its tools.”

MICHEL FOUCAULT, SURVEILLER ET PUNIR (1975)

ARSENAL

DECLIVITAS

“And when the prisoners began to speak, they had their own theory of prison, punishment, and justice. What really matters is this kind of discourse against power, the counter- discourse expressed by prisoners or those we call criminals, and not a discourse on criminality.”

GILLES DELEUZE, MICHEL FOUCAULT, INTELLECTUALS AND POWER (1972)

ARSENAL

DECLIVITAS

“I would agree that we are certainly in no position to create a system of ideal justice, just as we are in no position to create an ideal society in our minds. We don’t know enough and we’re too limited and too biased and all sorts of other things. But we are in a position—and we must act as sensitive and responsible human beings in that position— to imagine and move towards the creation of a better society and also a better system of justice.”

NOAM CHOMSKY, MICHEL FOUCAULT, HUMAN NATURE: JUSTICE VERSUS POWER (1974)

ARSENAL

DECLIVITAS

Still considered as a proper milieu d'enfermement, the project aims to concentrate, distribute in space, order in time and compose a productive force in the dimension of space-time. For this purpose, the typology aspires to oppose the classic confinement scheme (thick walls, heavily controlled space, highly fragmented spaces and so on) and proposes new means of creating a secured environment. It aims to avoid an abundance of material mass, often used as an instrument of power over body, by working more subtly with opening, full and empty spaces, circulation, transparencies, and the opportunity of verticality.

“A total institution may be defined as a place of residence and work where a large number of like-situated individuals, cut off from the wider society for an appreciable period of time, together lead an enclosed, formally administered round of life.”

ERVING GOFFMAN, ASYLUMS (1961)

ARSENAL

DECLIVITAS

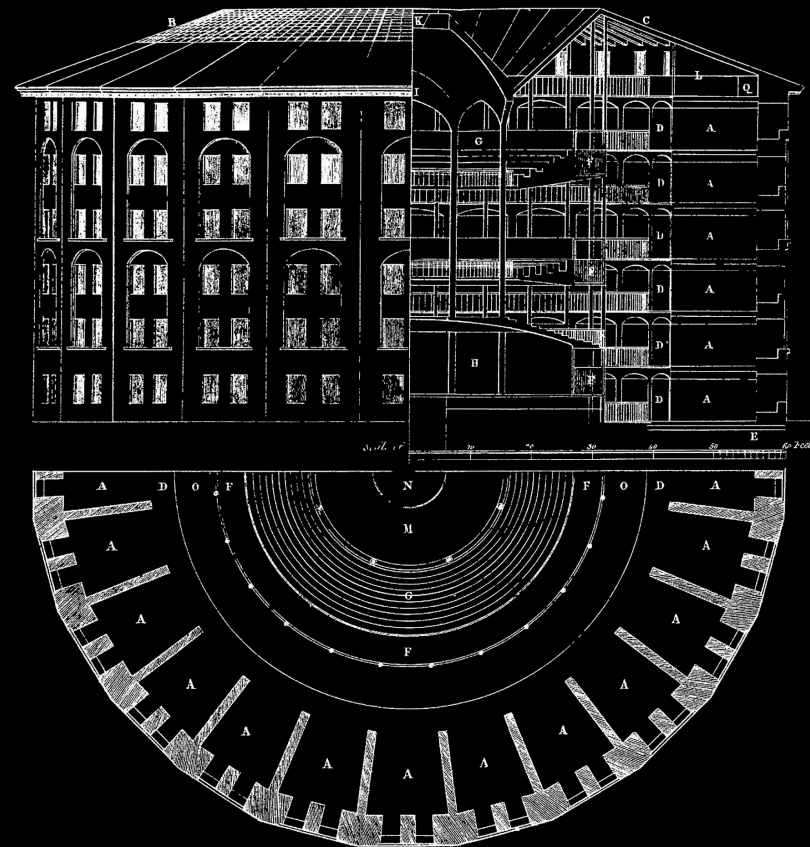

JEREMY BENTHAM, PANOPTICON (1791)

ARSENAL

DECLIVITAS



LACATON & VASSAL, TRANSFORMATION OF 530 DWELLINGS, BORDEAUX (2016)

ARSENAL

DECLIVITAS

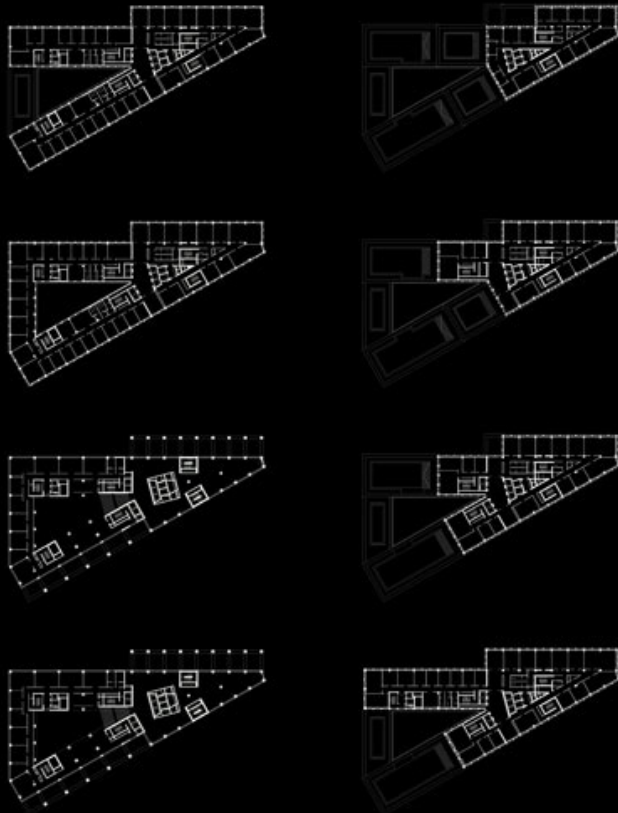

HANS KOLLHOFF, KOLLHOFF TOWER (1999)

ARSENAL

DECLIVITAS

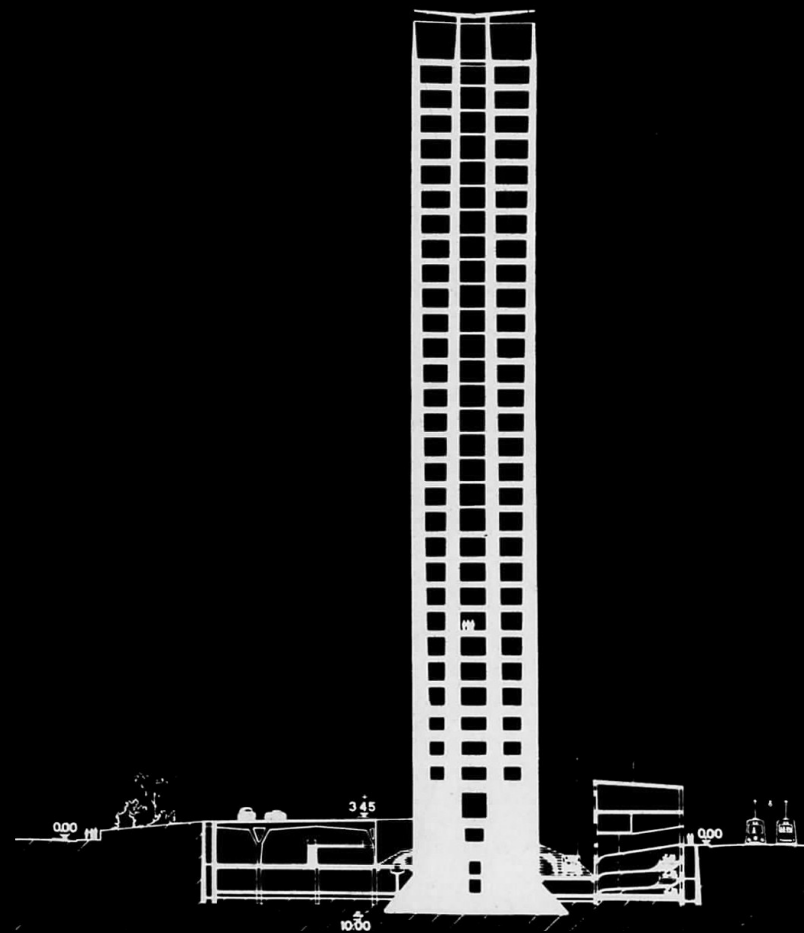

GIO PONTI, PIER-LUIGI NERVI, GRATTACIELO PIRELLI (1960)

ARSENAL

DECLIVITAS

Time, being a basic structural dimension of prison life, is sometimes witnessed as one of the main factors of failure of classical enclosed systems. Indeed, being in a constructed macrocosm mirroring society often means being in a place where events go on at a repetitive pace. The absence of any fundamental change gives a sensation of time stopping, often witnessed by prisoners. Time and space having an integral relationship in such an environment (necessity to be at a certain place at a certain time), the project focuses on bringing back fundamental changes that are able to avoid these problems of feeling of 'time-stopping'. As such, it proposes to focus on the possibility of a constant downward movement offered by the verticality of the building. Throughout time, the typology would allow prisoners to witness a variety of spaces in direct relation with the evolution of their re-learning progresses. The downward movement in the building, and thus the approach to ground level, corresponds to the path toward liberation.

“Separating the time relationship from the place relationship is only justifiable analytically: in terms of the prison experience, the temporal and spatial aspects of existence ... are experienced synthetically.... Inmates’ experience attests to the fact that the prison is a sophisticated time-place, where the temporal and the spatial characteristics are structurally productive of prison life and culture.”

DIANA MEDLICOTT, SURVIVING IN THE TIME MACHINE (1999)

ARSENAL

DECLIVITAS



SANDRO BOTTICELLI, LA VORAGINE INFERNALE (UPSIDE DOWN) (1480)

ARSENAL

DECLIVITAS

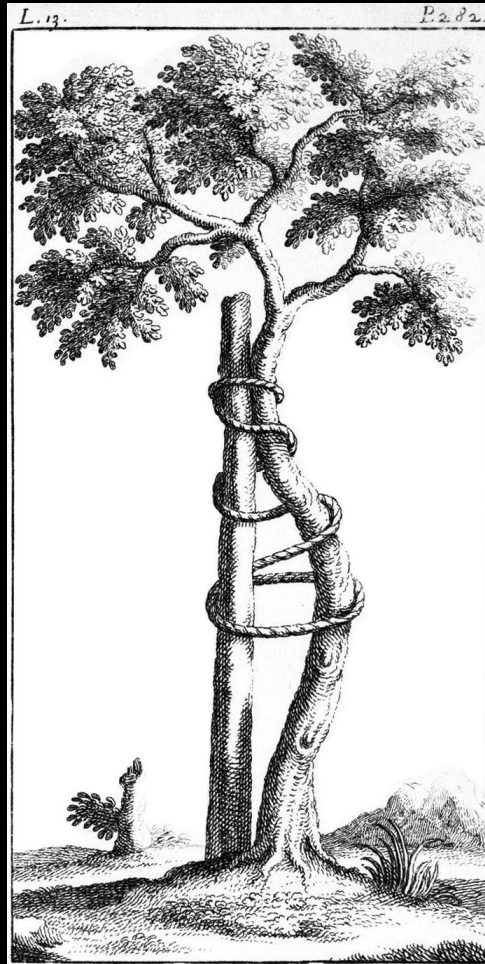

NICOLAS ANDRY, L'ORTHOPÉDIE OU L'ART DE PRÉVENIR ET DE CORRIGER DANS LES ENFANTS LES DIFFORMITÉS DU CORPS (1749)

ARSENAL

DECLIVITAS

In order to propose an environment with the capacity to re-introduce people to life in society, the question of bodies becomes primordial as the carceral environment foremost apply strict surveillance over the movement of bodies. The aim of a milieu d'enfermement is indeed to keep bodies in place, but it also limits its possibility to affect, be affected and create personal relations with its surroundings. Proposing an environment that is still able to extend the limit of what a body can do, even though remaining in the secured area, might have a real impact on the rehabilitation. As such, the project aims to rather express the movement of bodies in the building through a rhizome, being able to move freely in the environment. This allows for a confluence of relationships to emerge in the way bodies, not only physical but also environmental, react to one another. Through the freedom of movement, a so-called assemblage is created, embodied rather by normalization than forbiddance, always aiming to mirror society in the most accurate way.

“We are in a social formation; first see how it is stratified for us and in us and at the place where we are; then descend from the strata to the deeper assemblage within which we are held; gently tip the assemblage, making it pass over to the side of the plane of consistency. It is only there that the BwO [Body without Organs] reveals itself for what it is: connection of desires, conjunction of flows, continuum of intensities.”

“The idea of detention in closed space as a form of human punitive corrective action seems to have come in the thirteenth and fourteenth centuries - at the time perspective and pictorial space was developing in our Western World. The whole concept of enclosure as means of constraint and as means of classifying doesn't work as well in our electronic world. The new feeling that people have about guilt is not something that can be privately assigned to some individual, but is, rather, something shared by everybody, in some mysterious way. [...] This feeling is an aspect of the new mass culture we are moving into - a world of total involvement in which everybody is so profoundly involved with everybody else and in which nobody can really imagine what private guilt can be anymore.”



EDWARD HOPPER, MORNING SUN (1952)

ARSENAL

DECLIVITAS

III. PROJECT

The K26 building is located in the center of the Klybeck site, giving it particular importance in the organization of the different parts of the site. It was originally a storage building for raw materials. Due to its particularly high payload, the building's structure, made entirely of reinforced concrete, is extremely strong. In addition, as certain inflammable substances were stored, safety standards were also very high. The seven-stories typology is characterized above all by its openness and its free plan, marked only by the so-called mushroom columns that form the structure. The facade is characterized by a resolutely modern aesthetic, constituted of a strong symmetry and banded windows outlined by fine metal joinery.

The highly oversized structure gives the possibility to imagine an important raising of the building. Moreover, the open typology leaves room for the integration of very different programs. These qualities allow the K26 building to be rehabilitated and developed as a protected environment. Besides, the project doesn't consider to change its outer expression and the existing apparent façade is preserved in its totality.

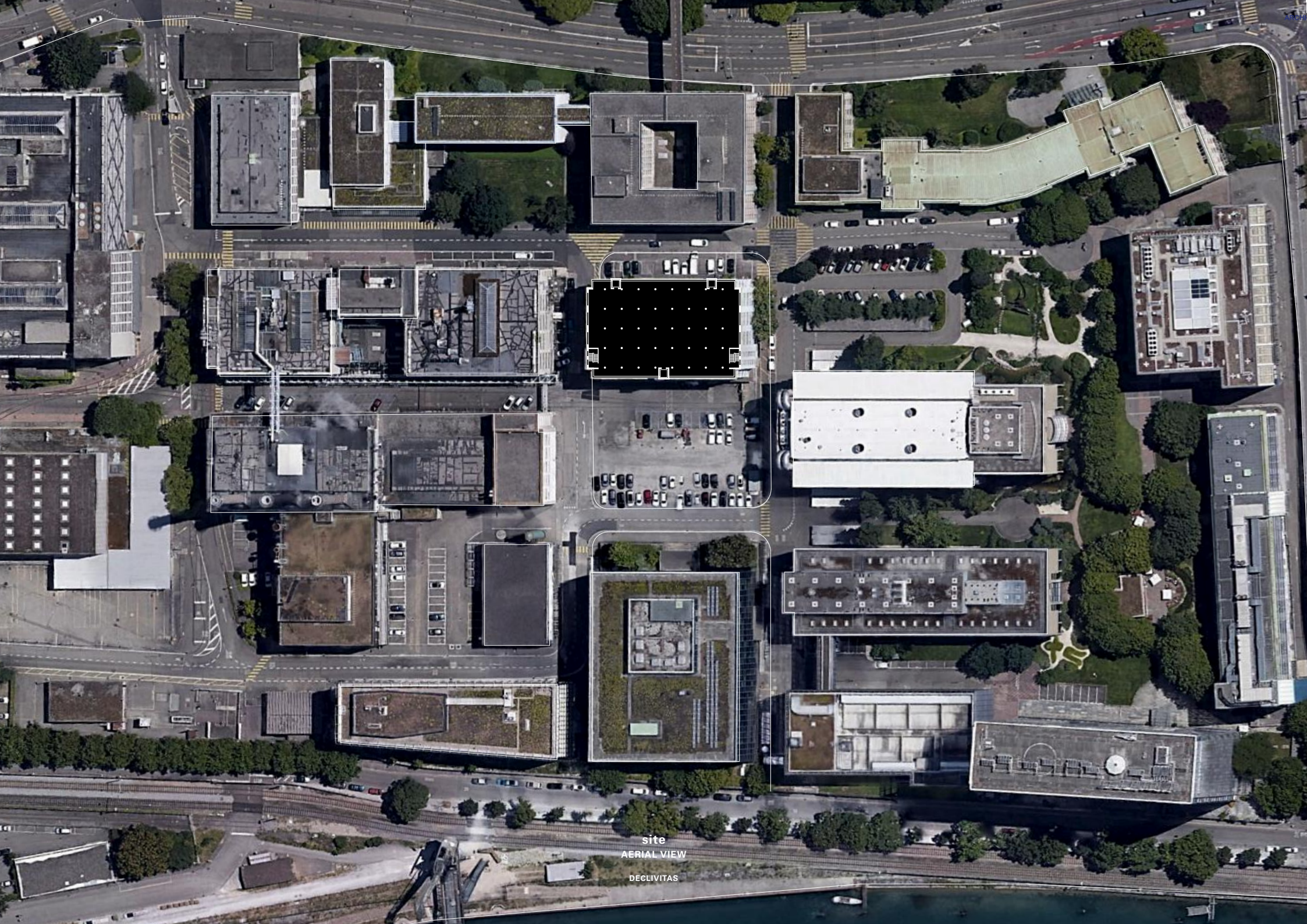

site
AERIAL VIEW
DECLIVITAS



north-west side

FLUBACHER NYFELER + PARTNER, K-26 (1937)

DECLIVITAS



south-east side

FLUBACHER NYFELER + PARTNER, K-26 (1937)

DECLIVITAS



interior

FLUBACHER NYFELER + PARTNER, K-26 (1937)

DECLIVITAS



interior

FLUBACHER NYFELER + PARTNER, K-26 (1937)

DECLIVITAS

The structure is composed of 40 so-called mushroom columns of 65 cm in diameter which support on each floor a slab of 25 cm thick and 1320 m² in surface area. Each column thus acts on an area of 28.5 m² on average, its said influence zone. The horizontal forces exerted on this zone are only taken up by the column concerned. At the time of the warehouse, the load considered on the zone of influence was 17 kN. Today, however, this is reduced to just 5 kN by the change of use. This allows the building to be raised by a maximum of 21 additional stories according to the calculation of the maximum load taken up by all the columns in the basement.

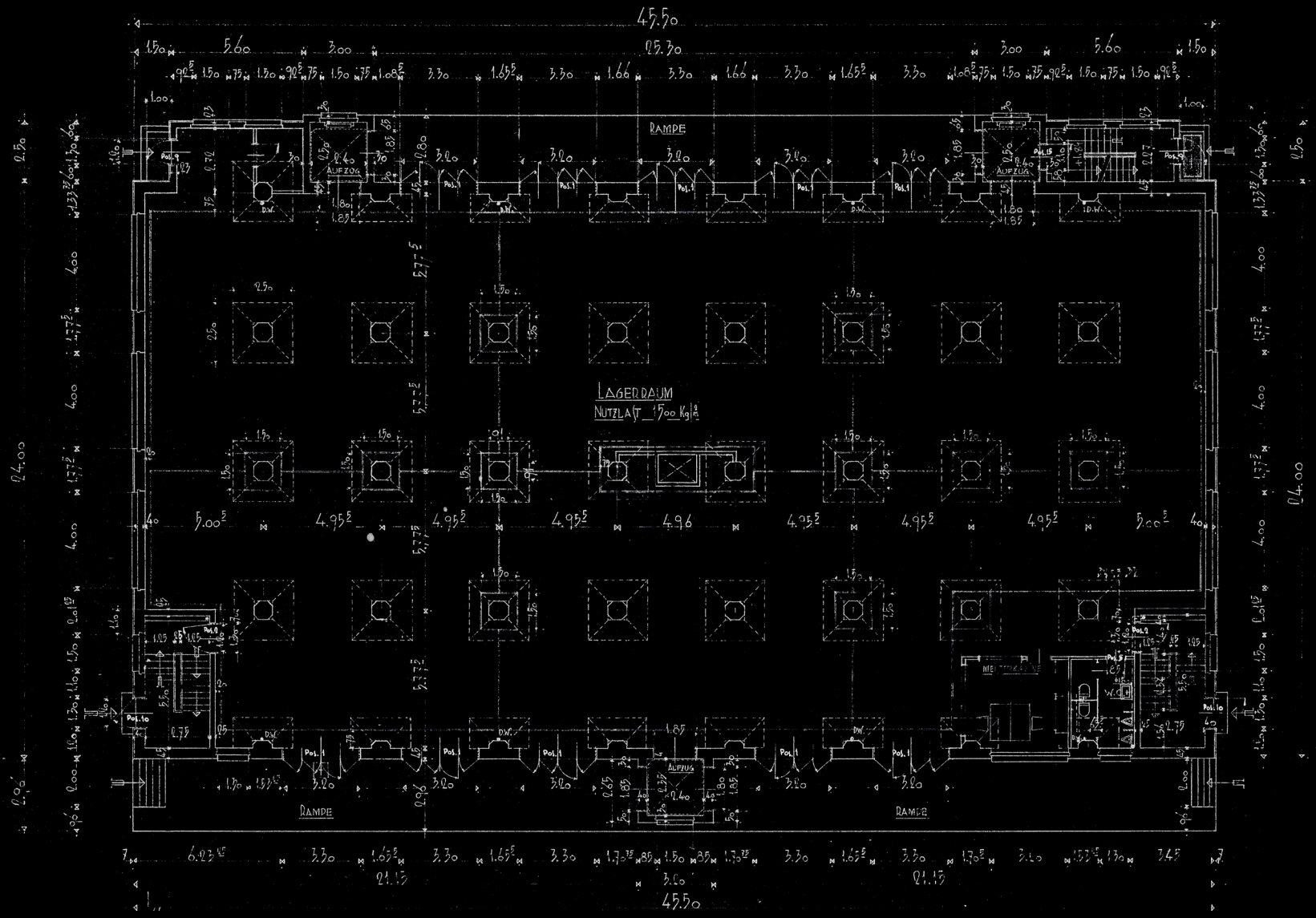

ground floor

FLUBACHER NYFELER + PARTNER, K-26 (1937)

DECLIVITAS

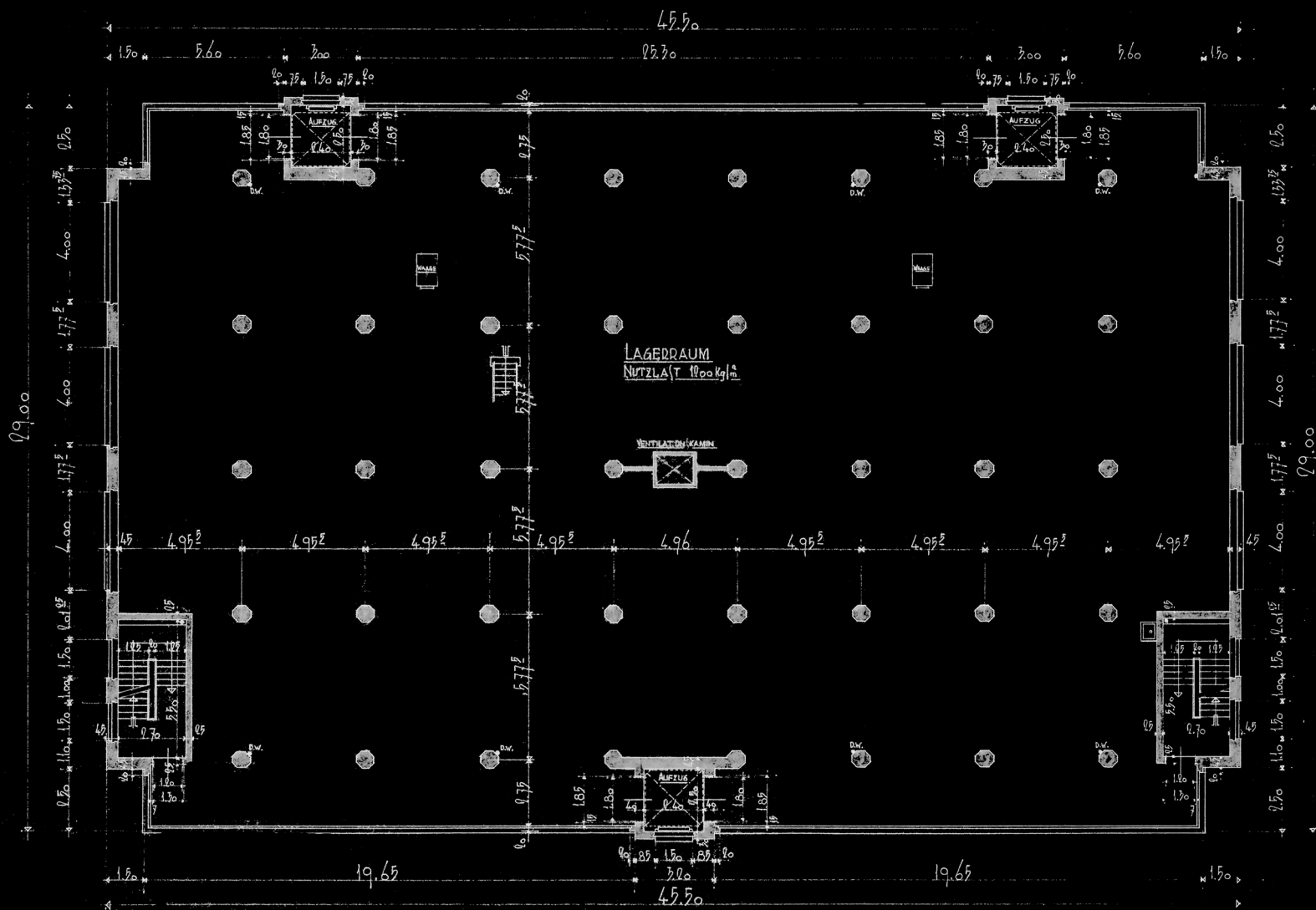

3rd floor

FLUBACHER NYFELER + PARTNER, K-26 (1937)

DECLIVITAS

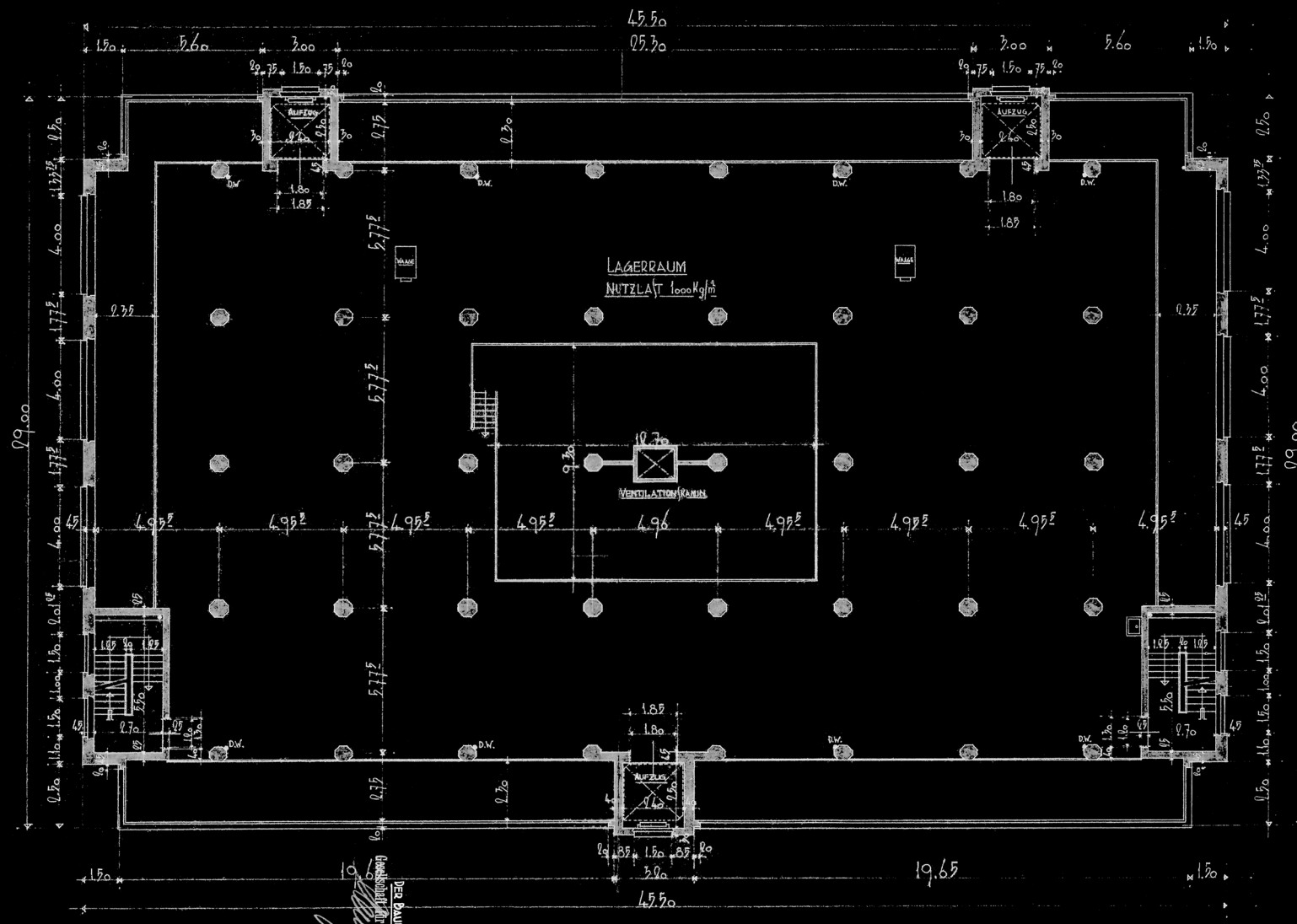

4th floor

FLUBACHER NYFELER + PARTNER, K-26 (1937)

DECLIVITAS

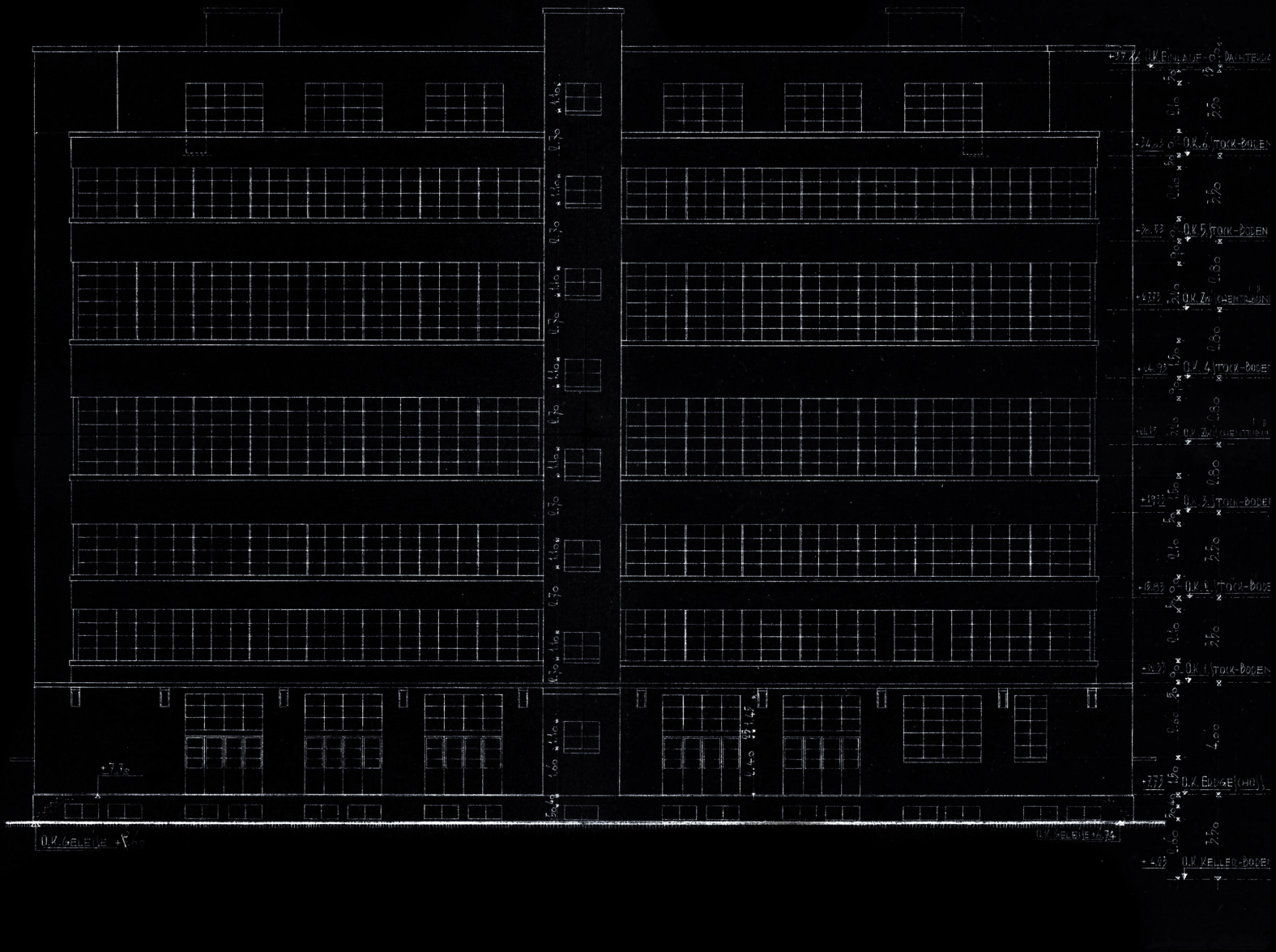

west façade
 FLUBACHER NYFELER + PARTNER, K-26 (1937)

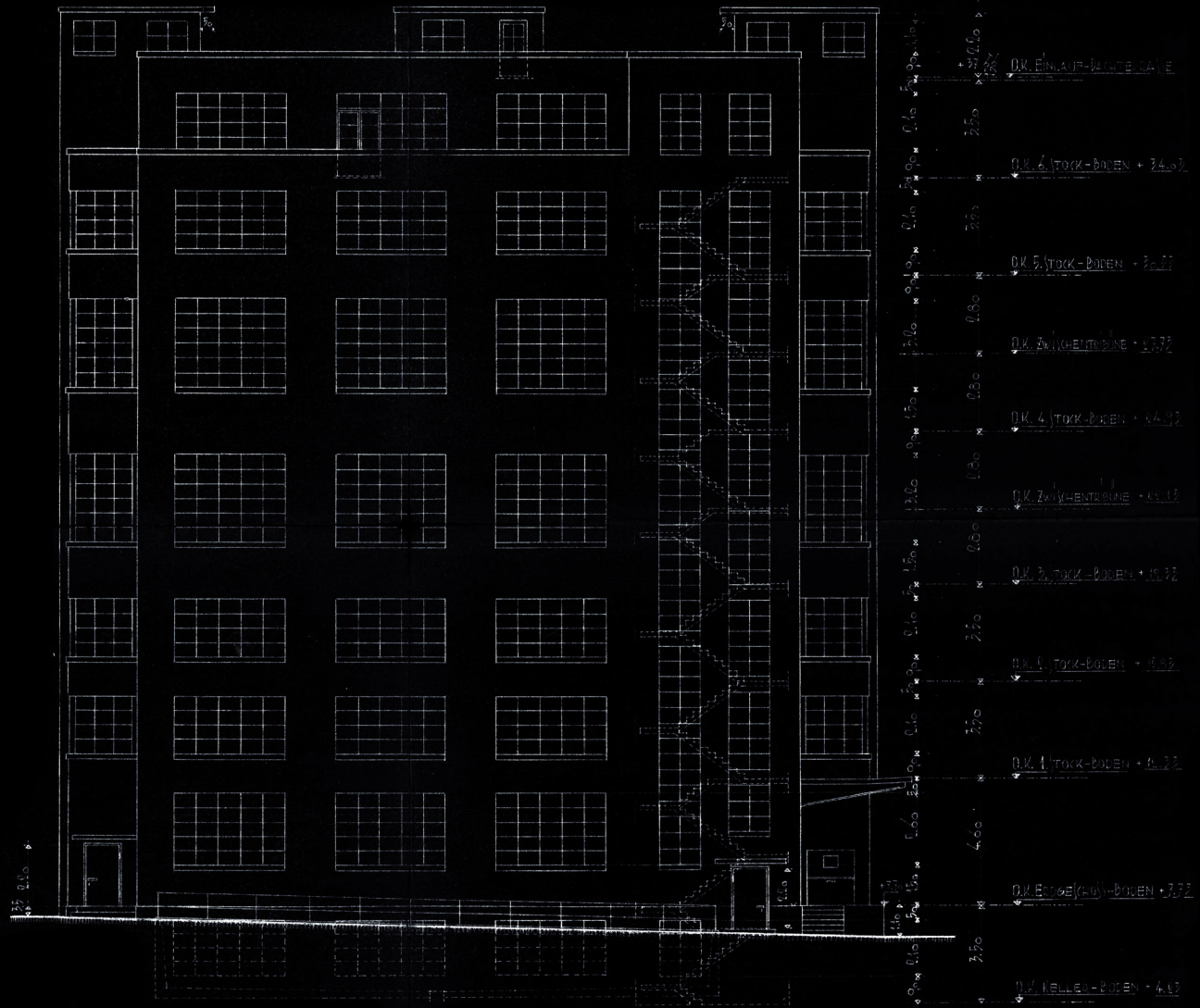

north façade
 FLUBACHER NYFELER + PARTNER, K-26 (1937)

DECLIVITAS

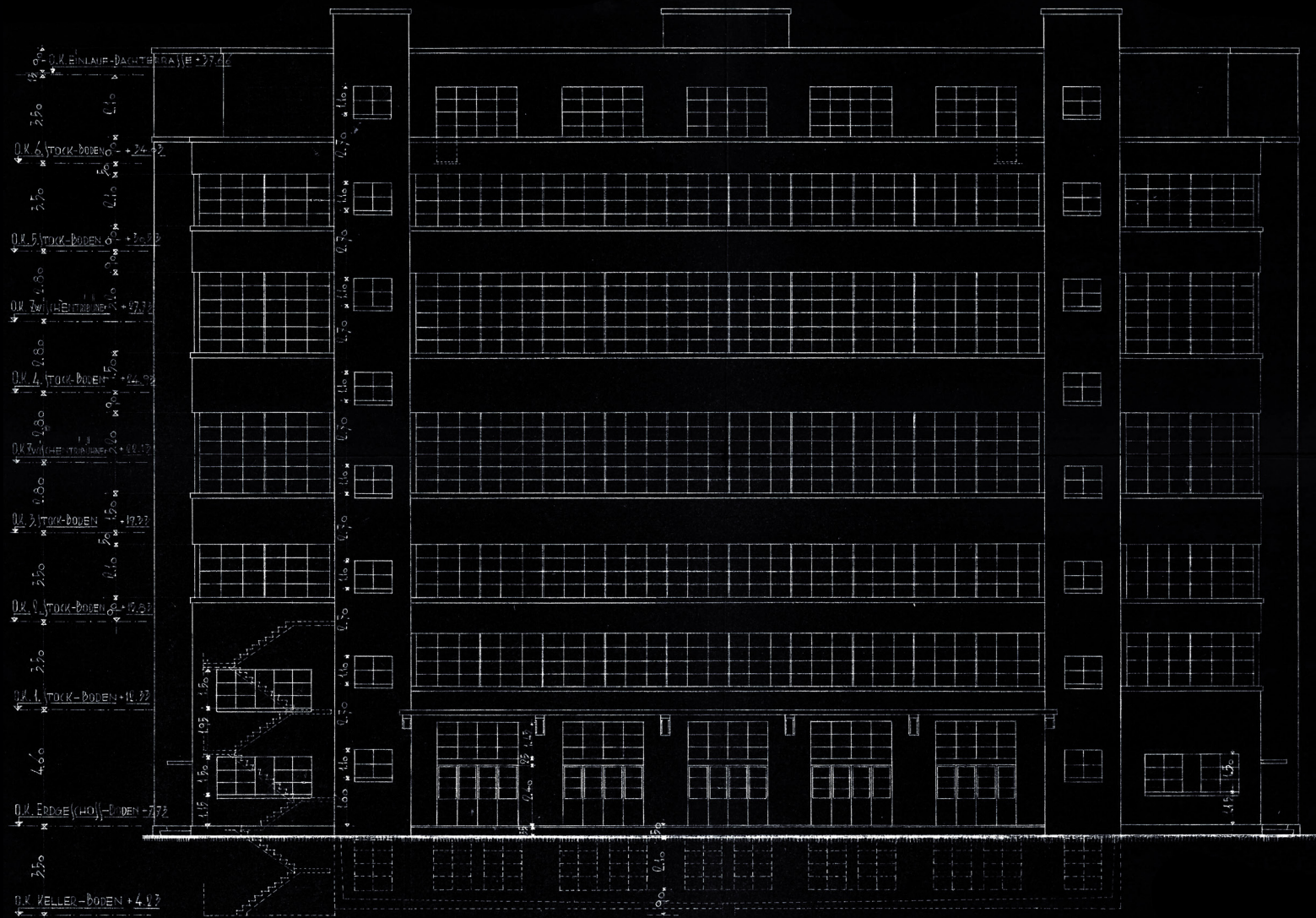

east façade
 FLUBACHER NYFELER + PARTNER, K-26 (1937)

DECLIVITAS

STRUCTURAL CALCULATIONS - POSSIBLE EXTENSION

concrete C20/25
reinforcement steel B500A

$$f_{cd} = 13.5 \text{ N/mm}^2 = 2'500 \text{ kg/m}^3$$
$$f_{sd} = 435 \text{ N/mm}^2$$

total floor surface
acting surface on a column

$$1'140 \text{ m}^2$$
$$5.77 \text{ m} \times 4.95 \text{ m} = 28.5 \text{ m}^2$$

surface of concrete in one column
surface of steel in one column

$$A_c = 0.4 \times 0.4 \times \pi = 0.5 \text{ m}^2$$
$$A_s = 500 \text{ mm}^2$$

charge utile
charge propre

$$q_k = 5 \text{ kN/m}^2$$
$$g_{sk} = 3 \text{ kN/m}^2$$

$NR_d \geq NEd$
 $NR_d = NEd$ - max. supported load

X = max. number of floors

maximal load supported by one column on floor -1

$$NRd \approx A_c \times f_{cd} + A_s \times f_{sd} = 500'000 \text{ mm}^2 \times 13.5 \text{ N/mm}^2 + 500 \text{ mm}^2 \times 435 \text{ N/mm}^2 = 6'965 \text{ kN}$$

maximal load supported by all the columns on floor -1

$$6'965 \text{ kN} \times 40 = \underline{278'600 \text{ kN}}$$

maximal charge utile

$$5 \text{ kN/m}^2 \times 1'140 \text{ m}^2 \times X = \underline{6'000 X \text{ kN}}$$

maximal charge propre

$$3 \text{ kN/m}^2 \times 1'140 \text{ m}^2 \times X = \underline{3'600 X \text{ kN}}$$

columns and slabs charge

$$[(0.65 \text{ m} \times 0.65 \text{ m} \times 3.5 \text{ m} \times X) + (28.5 \text{ m}^2 \times 0.25 \text{ m} \times X)] \times 2'500 \text{ kg/m}^3 \\ = 22'000 X \text{ kg} = \underline{218 X \text{ kN}}$$

maximal possible floor extension

$$(6'000 \text{ kN} + 3'600 \text{ kN} + 218 \text{ kN}) \times X = 278'600 \text{ kN}$$

$$9'818 X \text{ kN} = 278'600 \text{ kN}$$

$$X = 278'600 \text{ kN} / 9'818 \text{ kN} = \mathbf{28} \text{ (of which 7 already existing)}$$

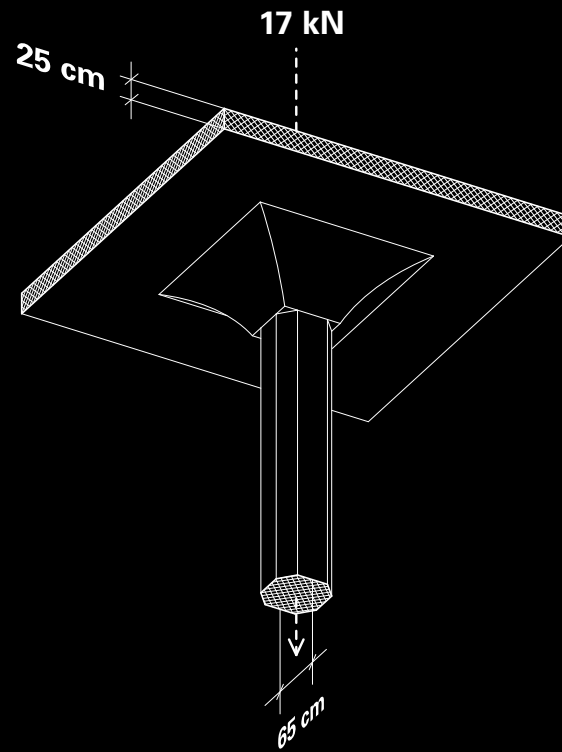

existing structure
DIAGRAM
DECLIVITAS

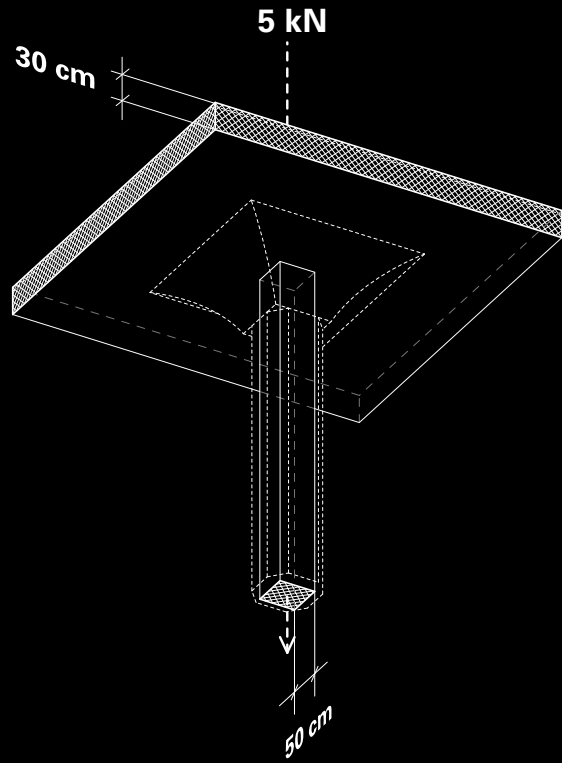

new structure
DIAGRAM
DECLIVITAS

The existing architecture is already distributed by an efficient vertical circulation: three elevators and two staircases located on the periphery of the plan. Therefore, it is conceivable to reuse these and extend them along with the building extension. The west elevator will be dedicated to supervised movements, being only accessible to residents when accompanied by a staff member, and providing access to every floor of the building. The two east elevators, on the other hand, do not serve the upper floors, which are considered as high security. They are thus left in self-service for residents with lighter sentences, thanks to a magnetic card system. This helps to introduce a notion of trust in the movement of bodies within the building. The circulation of people within the building is superimposed by the technical flows that move through the ceilings at the level of corridors to reach the technical shafts located next to the elevators and leading every flux towards the basement. Moreover, a bigger shaft is found in the center of the building, allowing for transport of material in between floors and especially from the ground floor to the upper ones, until the 13th.

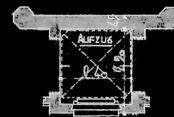
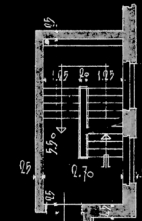
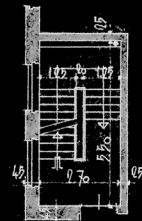
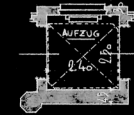
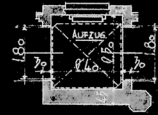

vertical circulation
FLUBACHER NYFELER + PARTNER, K-26 (1937)

DECLIVITAS

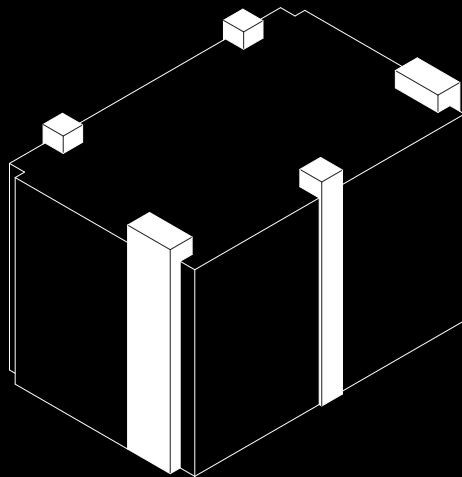

vertical circulation
DIAGRAM
DECLIVITAS

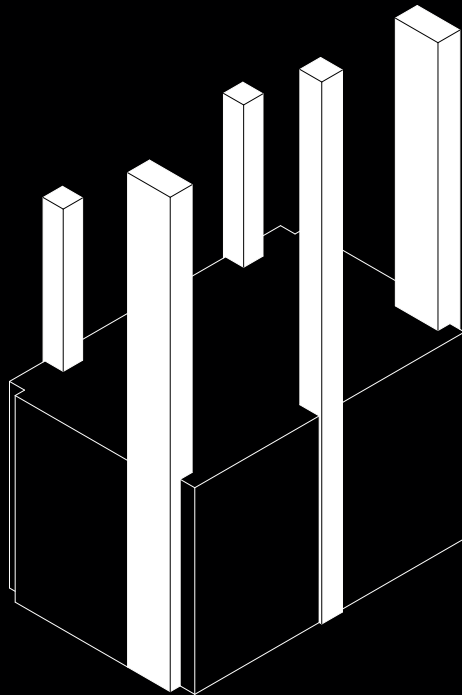

vertical circulation
DIAGRAM
DECLIVITAS

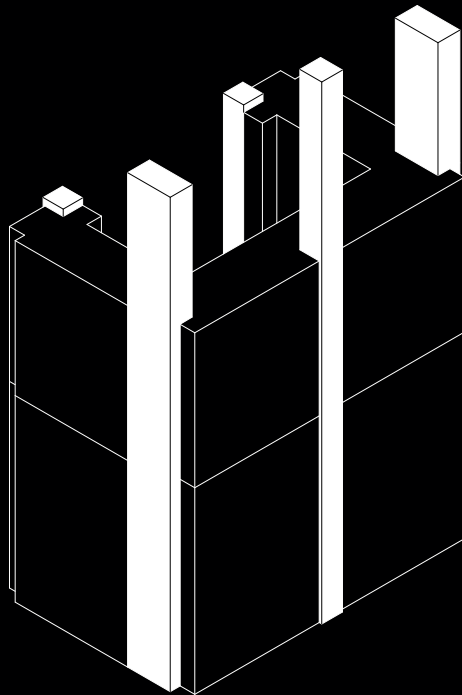

vertical circulation
DIAGRAM
DECLIVITAS

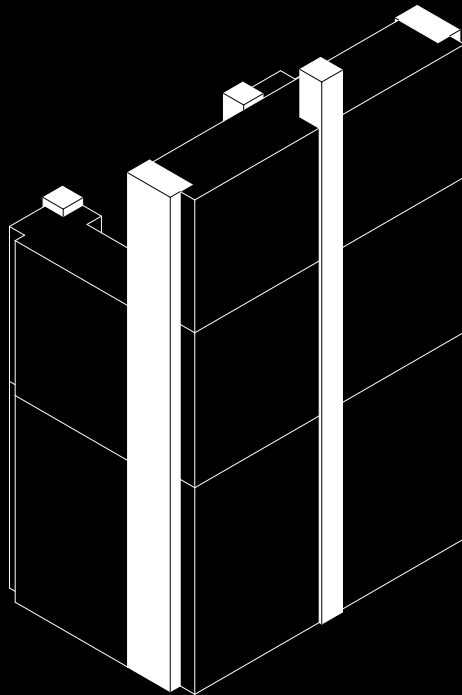

vertical circulation
DIAGRAM
DECLIVITAS

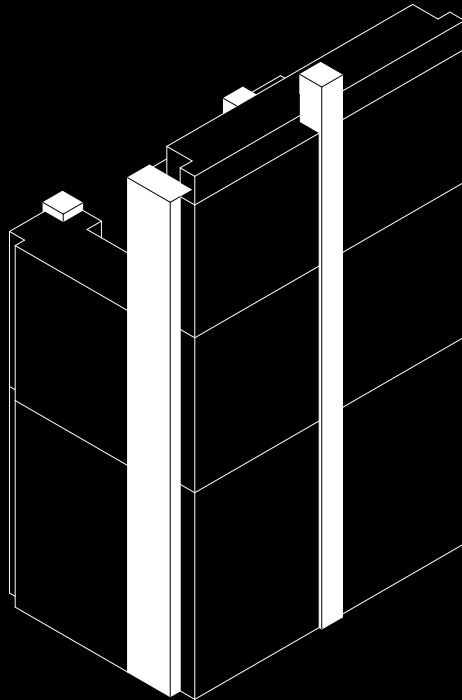

vertical circulation
DIAGRAM
DECLIVITAS

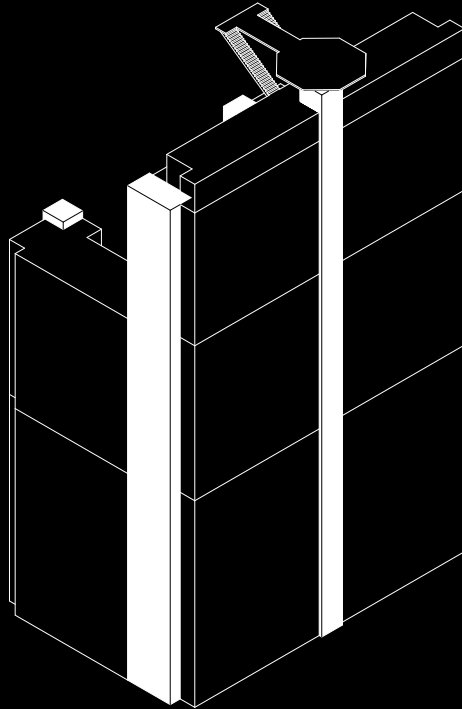

vertical circulation
DIAGRAM
DECLIVITAS

As the existing building is not insulated, the project proposes to add a layer of winter gardens around the entire perimeter of the plan in the existing part to create a buffer zone acting as insulation without affecting the expression of the façade. This gesture also provides a thicker skin to the building, introducing the notion of protection from the inside while maintaining a very important visual opening. Façade details are thus worked in this direction in order to develop the enclosing potential of the environment without isolating it completely.

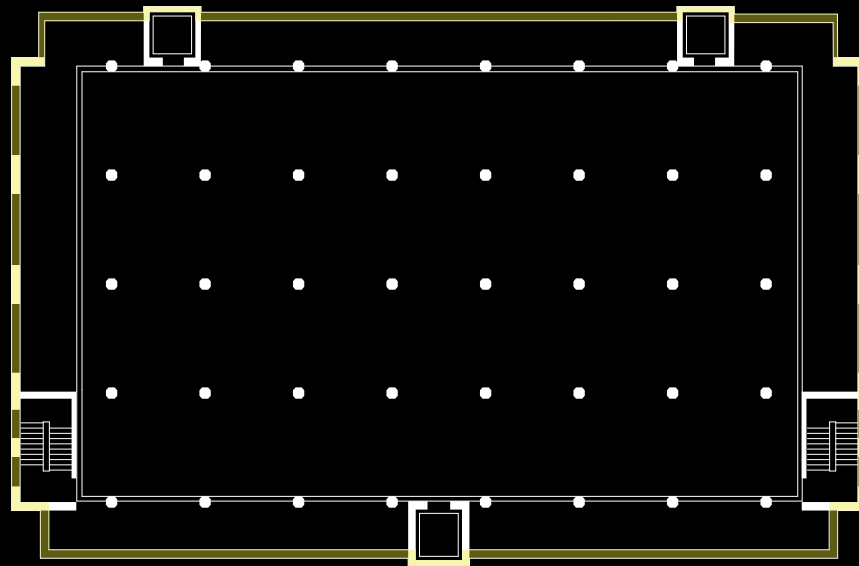

outer skin
DIAGRAM
DECLIVITAS

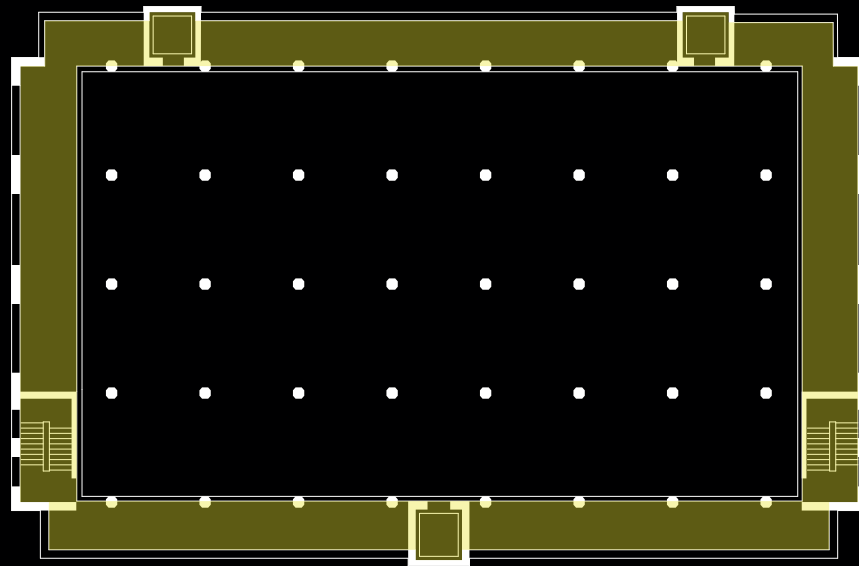

buffer zone
DIAGRAM
DECLIVITAS

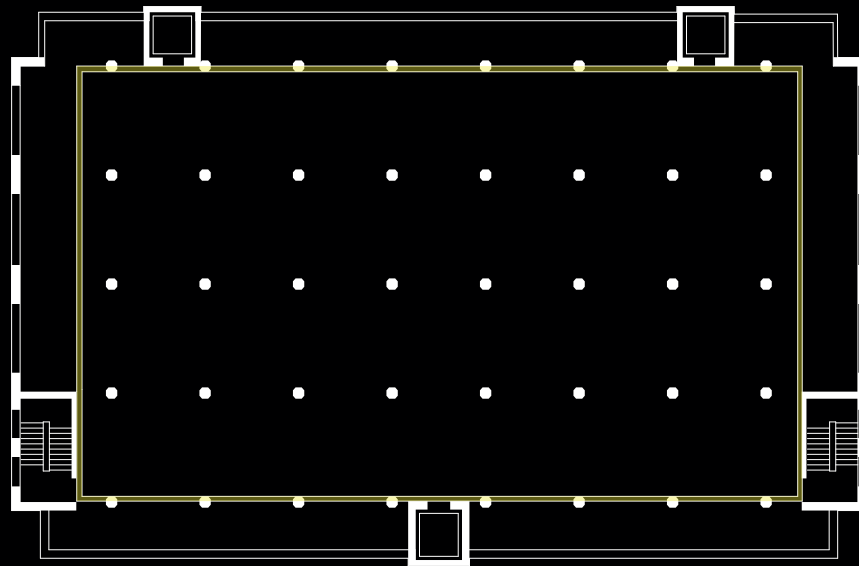

thermal barrier
DIAGRAM
DECLIVITAS

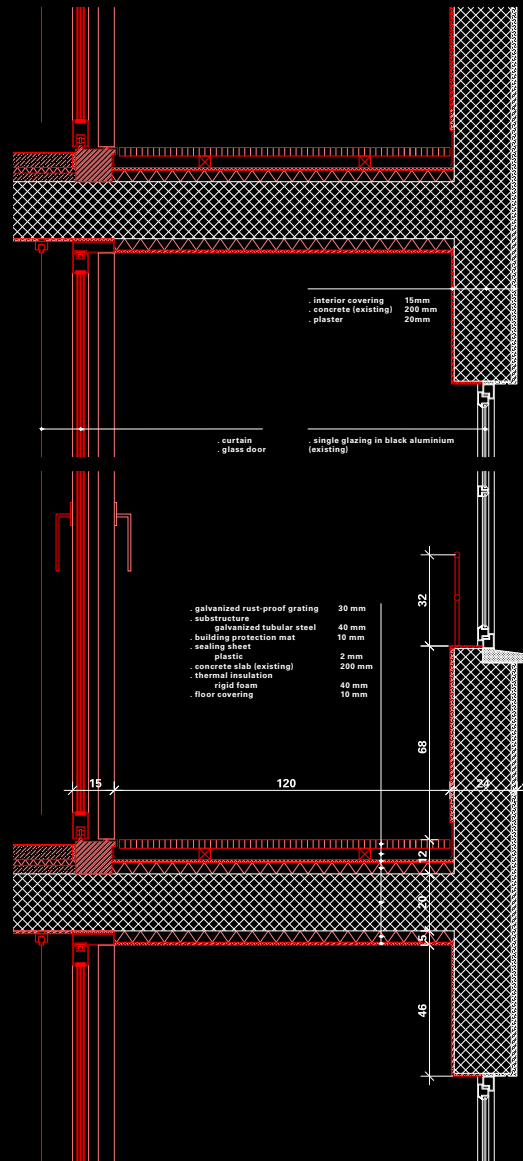

winter garden
DETAILS

DECLIVITAS

The movement of bodies within the building and the introduction of fundamental changes in time in order to avoid cyclical repetitions and the impression of time stopping remains one of the central points in the proposal of an alternative confined environment. A vertical movement from top to bottom is introduced into the very design of the typology, with inhabitants moving downwards throughout their residency, metaphorically and physically getting closer to society through the process of re-learning. This brings a form of ritual to prison time, from the entrance, at roof level, to the exit, on the ground floor.

It is considered that the occupants are brought by helicopter to the entrance of the building, on the roof. The resulting detachment from the ground is the first element of separation from society. The prisoner goes down to the building through an outer staircase, and after penetrating the building, is directed through different admission rooms. A ritual in the form of a sequence of rooms is formed, working as different layers that make the building permeable in only one direction: once in, the resident cannot exit from the same place, he is in a spiral that will gradually bring him down towards his freedom. The rooms are organized according to different typologies depending on the length of stay of each one, and always from top to bottom. The aim is to have the most individual and private spaces at the highest level and to open up to community life by descending, mainly through leisure activities, always with the idea of mirroring external society. In this way, the existing part of the tower is only composed of spaces for interaction and communication.

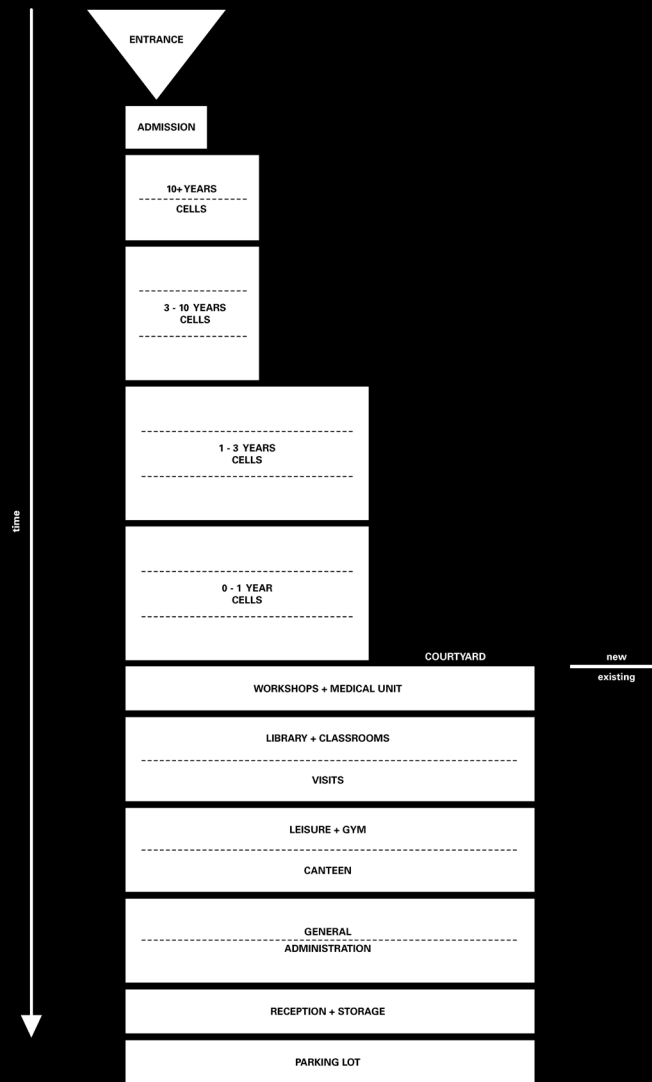

organigram
PROJECT
DECLIVITAS

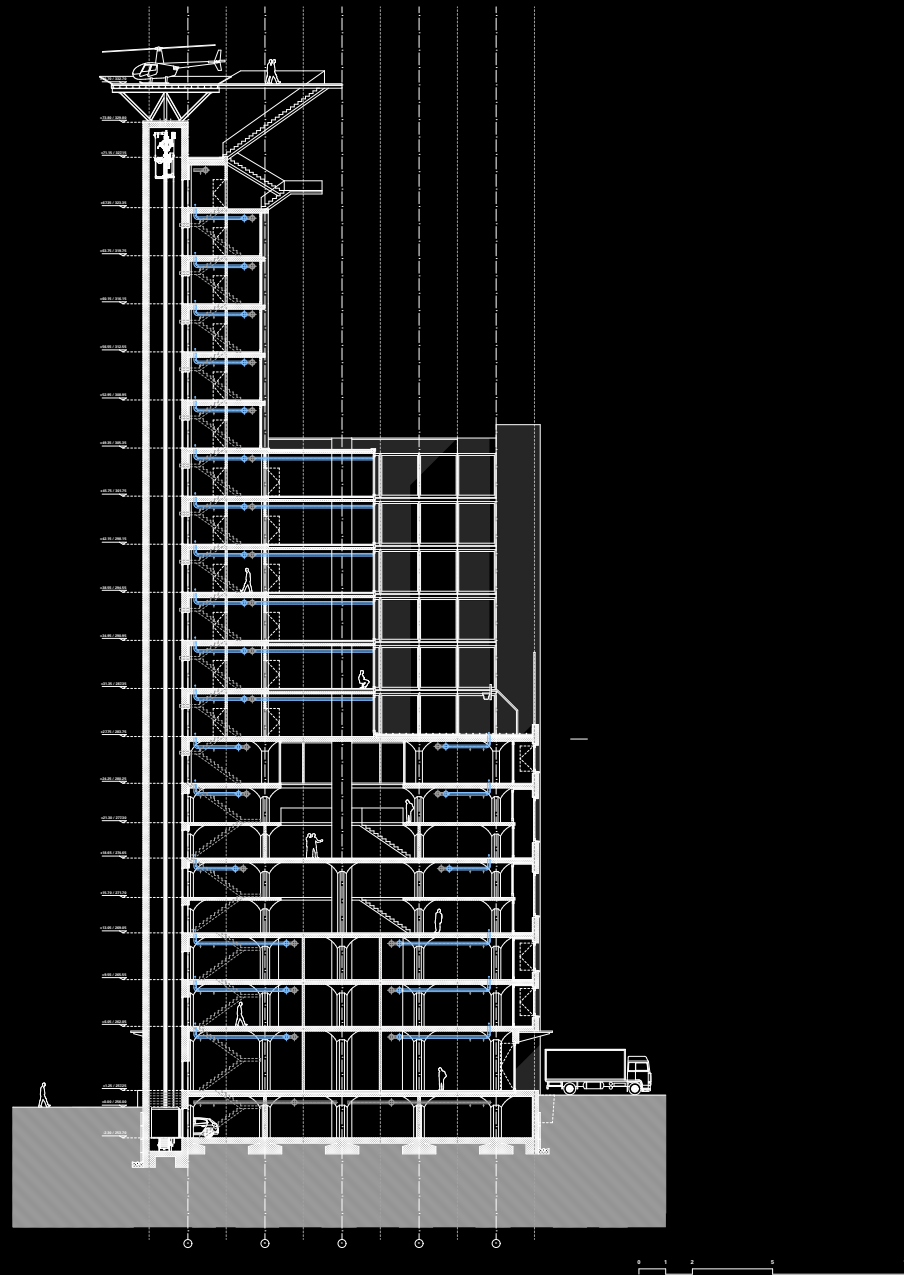

transversal section
PROJECT
DECLIVITAS

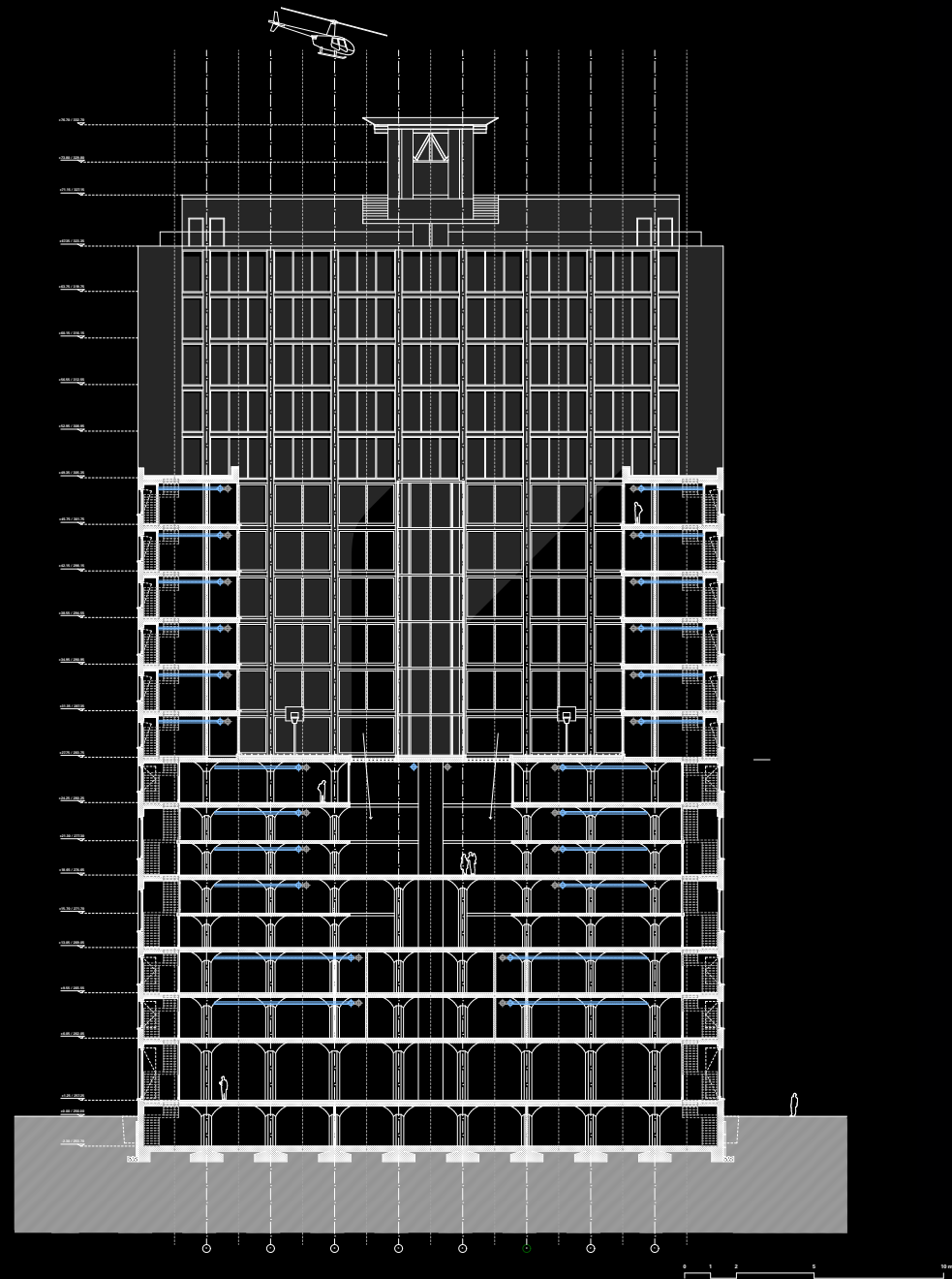

longitudinal section
PROJECT
DECLIVITAS

The project offers 140 prison places for which only 12 additional stories to the existing building out of the 21 that the structure allows are necessary. This amount of places makes it possible to imagine replacing Bässlergut prison, which currently has 73 places, to provide the city with the 40 necessary places, and to anticipate the possible slight increase in needs in the years to come. The building considers three different types of rooms, distributed vertically throughout the floors :

- for stays from 3 to 10 years or more, the 25 m² cells are very spacious with a large private bathroom and a living space. They are located on the five highest floors (below the administration), the two upper floors are reserved for residents with sentences of more than 10 years, and the next three floors are dedicated to stays of 3 to 10 years.

- the second typology concerns sentences of 1 to 3 years. It offers rooms of 20 m², also including a private bathroom and a small living space. These rooms are located on three floors, under the typology of stays from 3 to 10 years. At this level is introduced a control room in the center of the space, introducing surveillance, but allowing for total free movement of bodies on these floors that are considered as minor security.

- finally, the three lower floors of the extension are composed of the typology for residences of 0 to 1 year. The rooms are here reduced to the minimum with a surface of 12 m² and without private bathrooms. The reduction of individual space is implemented in order to encourage interaction within the common areas. The rooms are also starting to wrap around the central leisure space, leading the occupants more and more towards a communal life for a better reintegration into the external and unprotected society.

The surfaces of the floors gradually expand in the lower stories, coping with the idea of encouraging interaction as one descends and so providing always more and more shared space. The upper floors, on the opposite, emphasize intimacy, personal refocusing and confrontation with oneself above all else.

The lower floors, located in the renovated part of the previously existing building, hold all the communal programs as well as the administrative ones. On the 7th and 6th floors are all the workshop areas, the library, the teaching rooms as well as the medical and psychological consultation. These are organised around a large patio, allowing for natural light to enter the center of the 5th floor which is made of a large hall dedicated to visits and a few private rooms on the side. Under this floor is found a fitness and leisure area, and then the cafeteria which is used as the meeting point in between residents and workers as they all eat together. On the 2nd and 1st floors are all the administrative function, meeting rooms, resting areas for workers and so on. The ground floor is the entrance for the visitors and the personal, but also for all the material which is then contained in the warehouse on the same floor. Finally, the basement is a car parking.

The different typologies tend to continue the organization through strips of programs already undertaken with the room typologies, which allows a decomposition of the building in layers, in favor of the previously developed idea of thickening of the boundary. These seven floors, gradually less open to the residents, allow for the building to have some kind of foundation that detaches its main function from the ground and allow for a better protection of the environment.

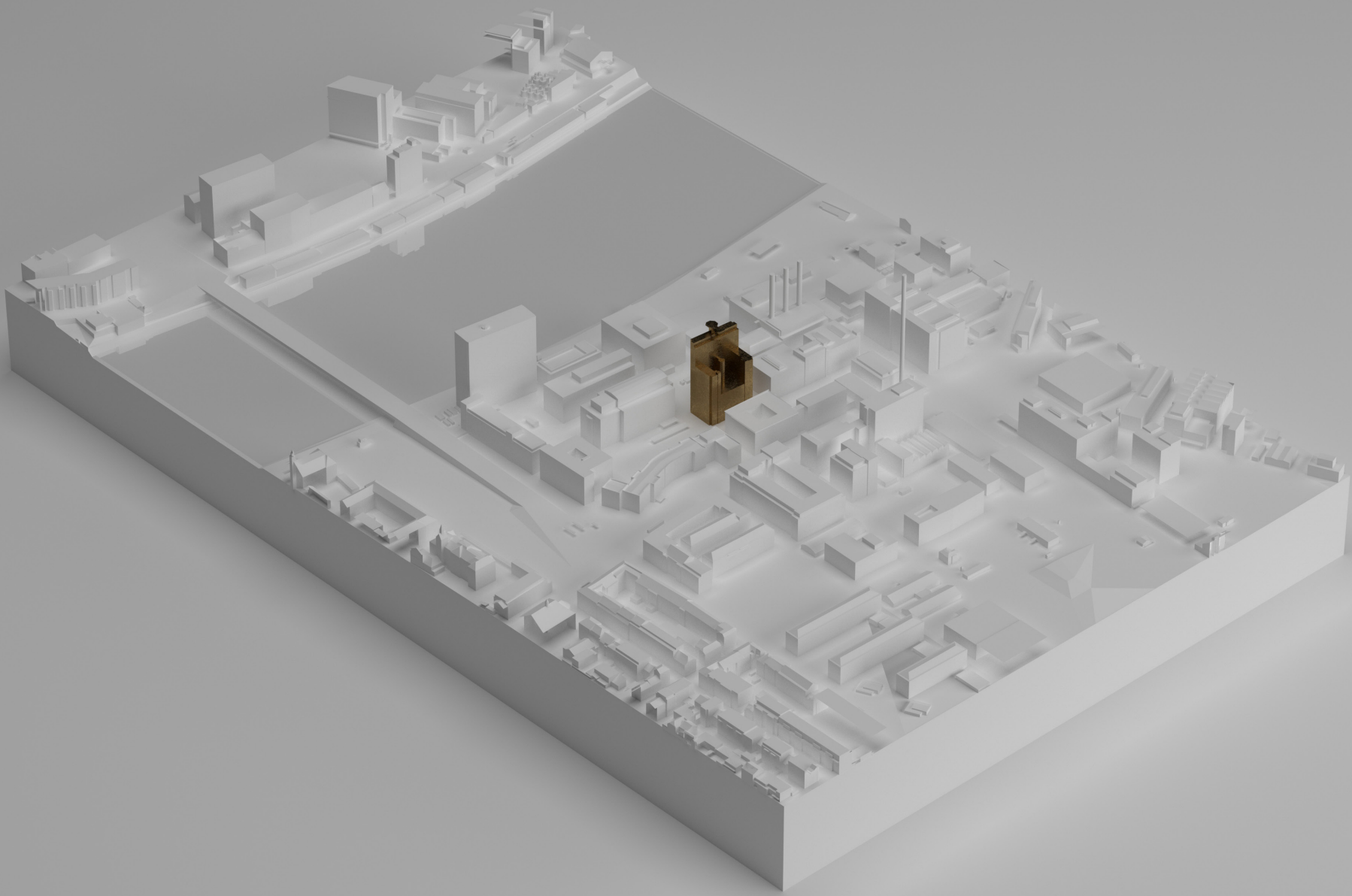

model south-east view
PROJECT
DECLIVITAS

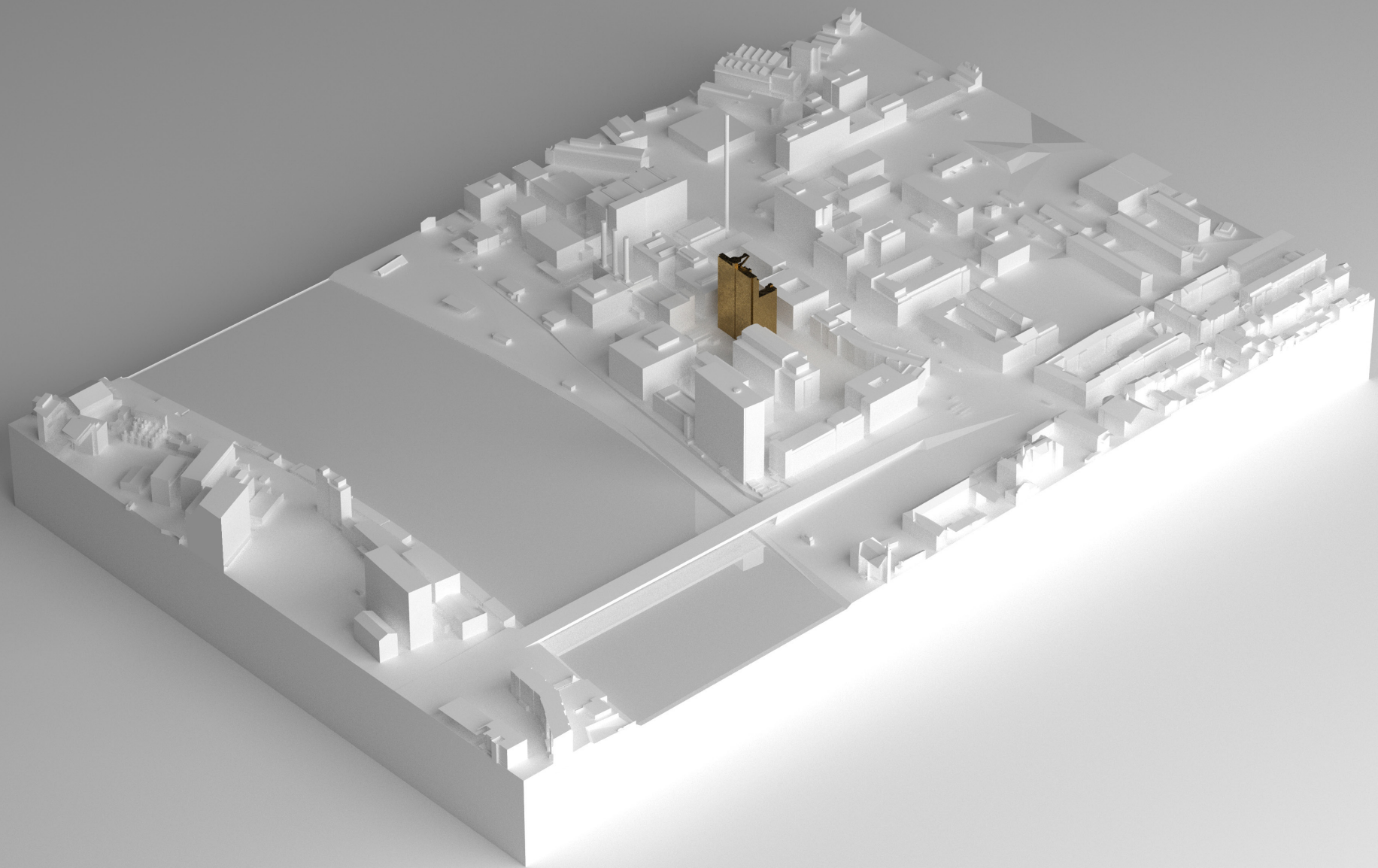

model south-west view
PROJECT
DECLIVITAS



orthophoto
PROJECT

DECLIVITAS

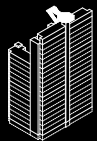
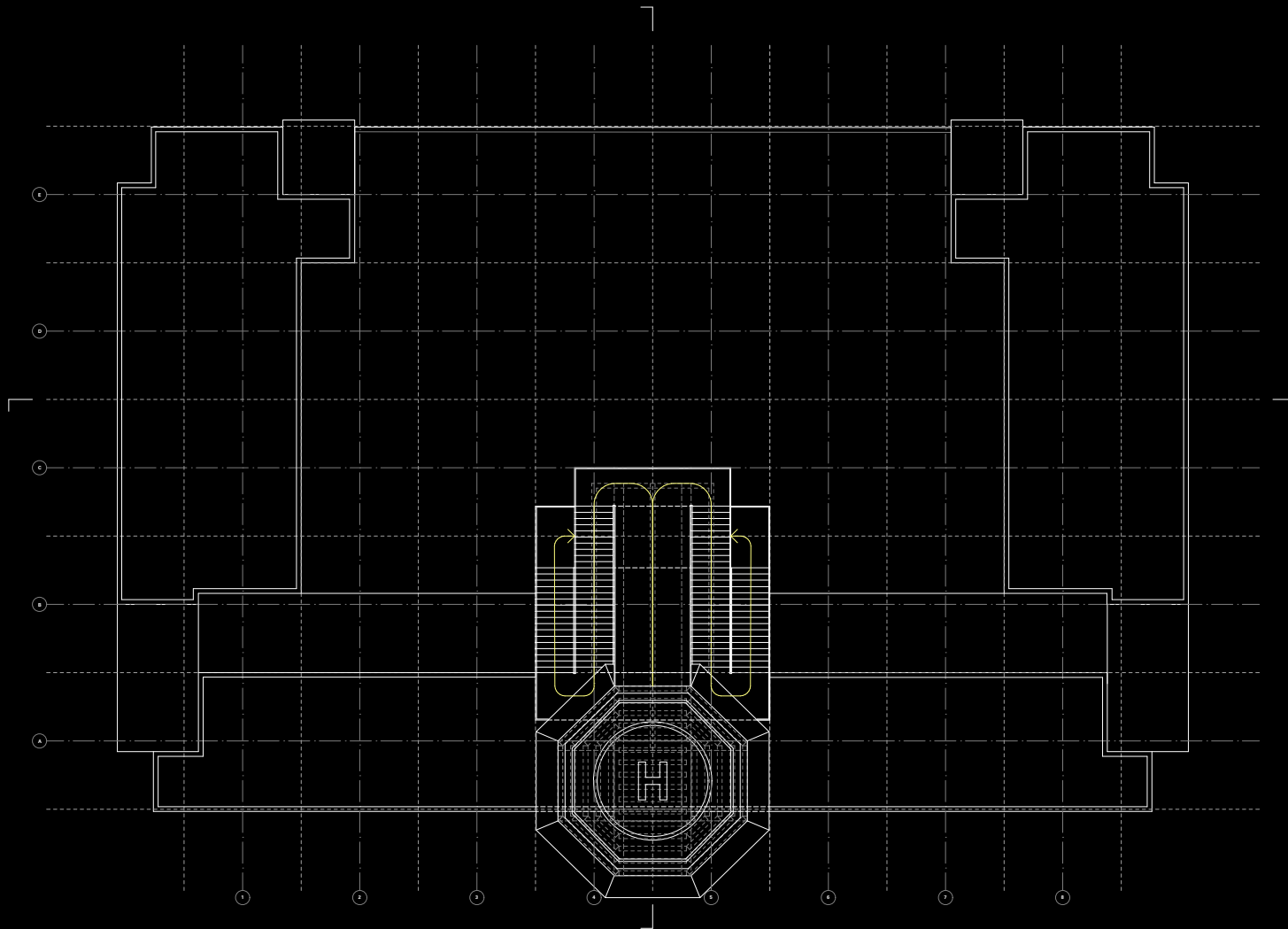

roof
PLAN

DECLIVITAS

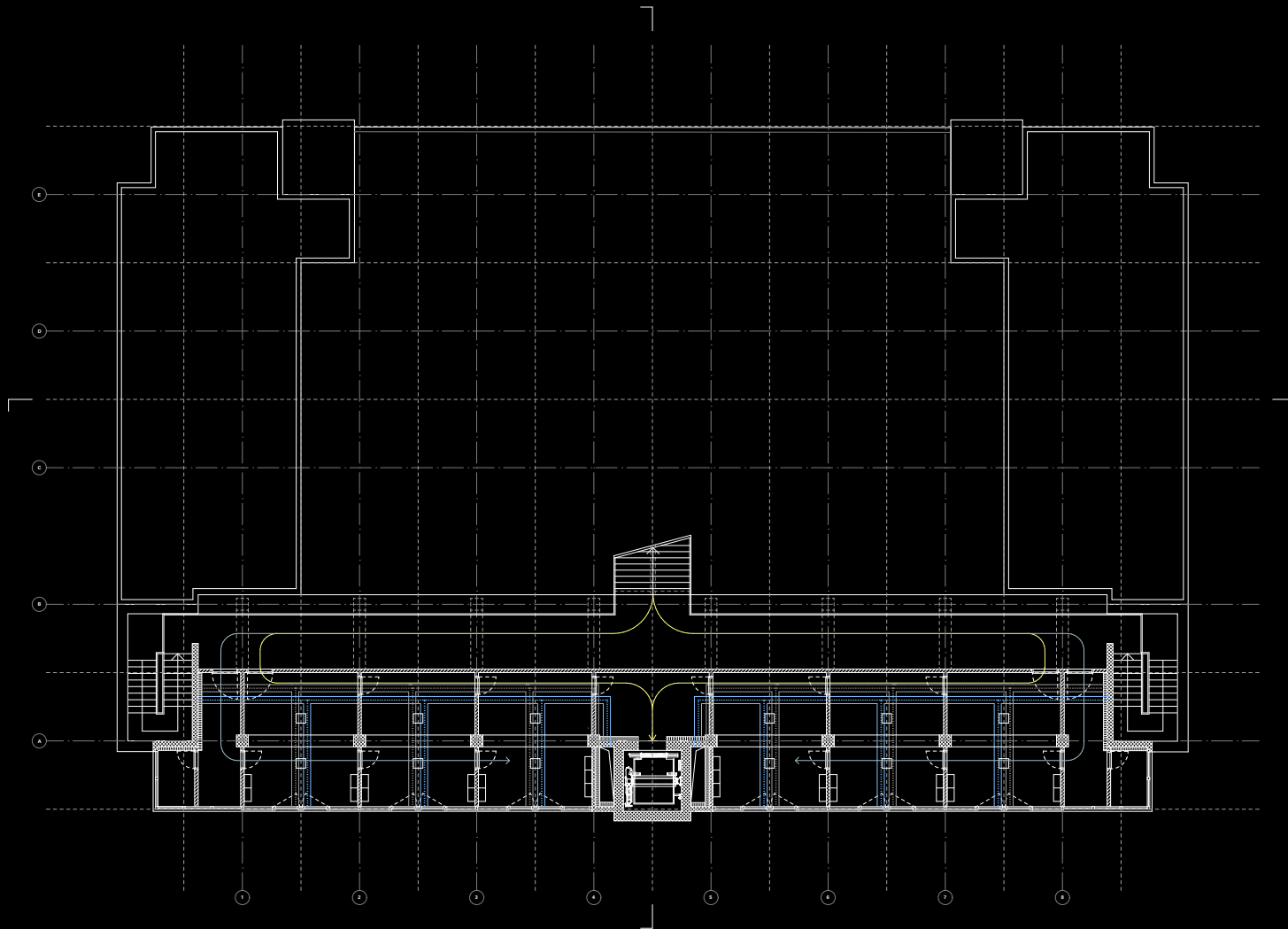

floor 19.
PLAN

DECLIVITAS

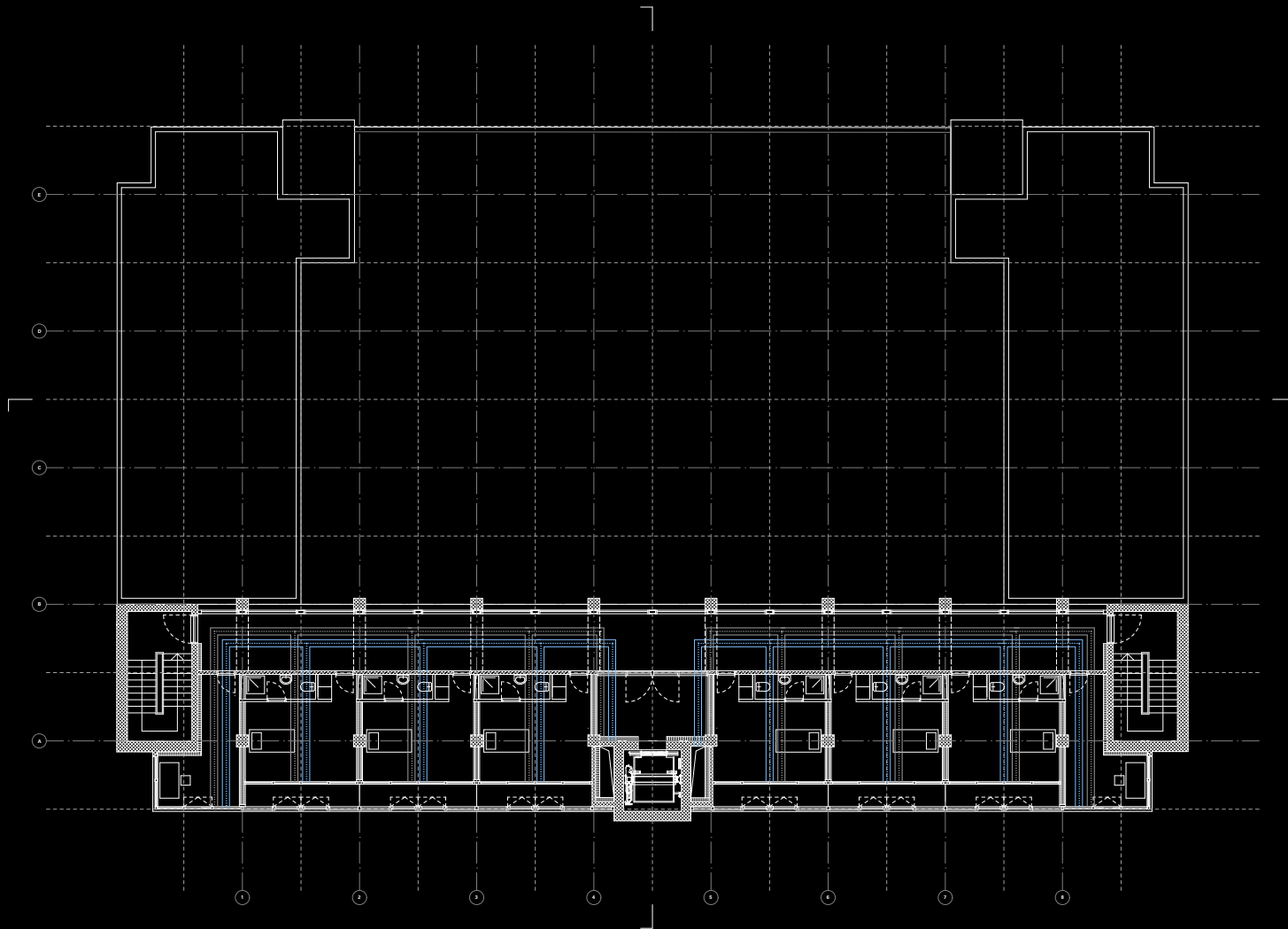

floors 14-18.
PLAN
DECLIVITAS

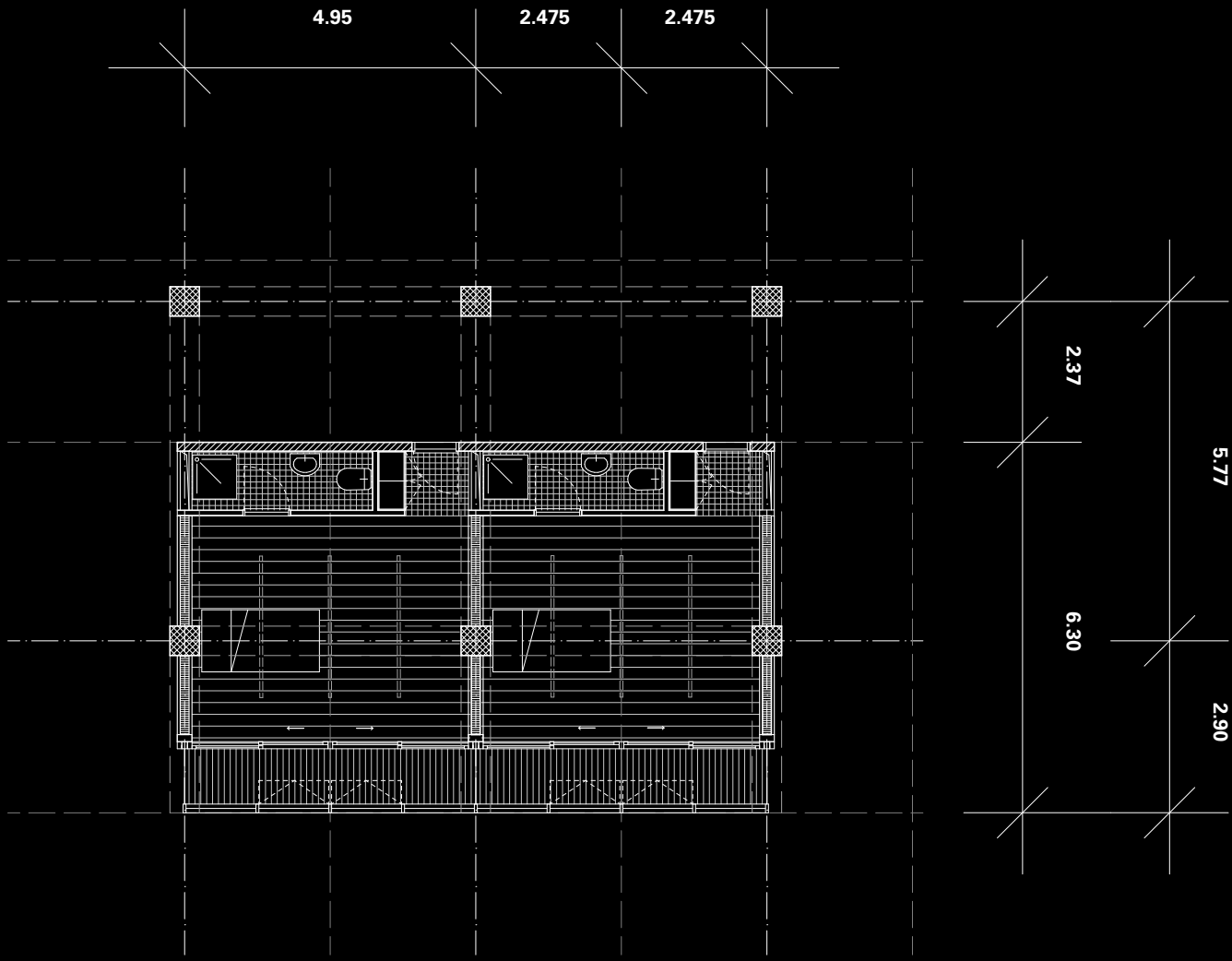

25 m² cells
 PLAN
 DECLIVITAS

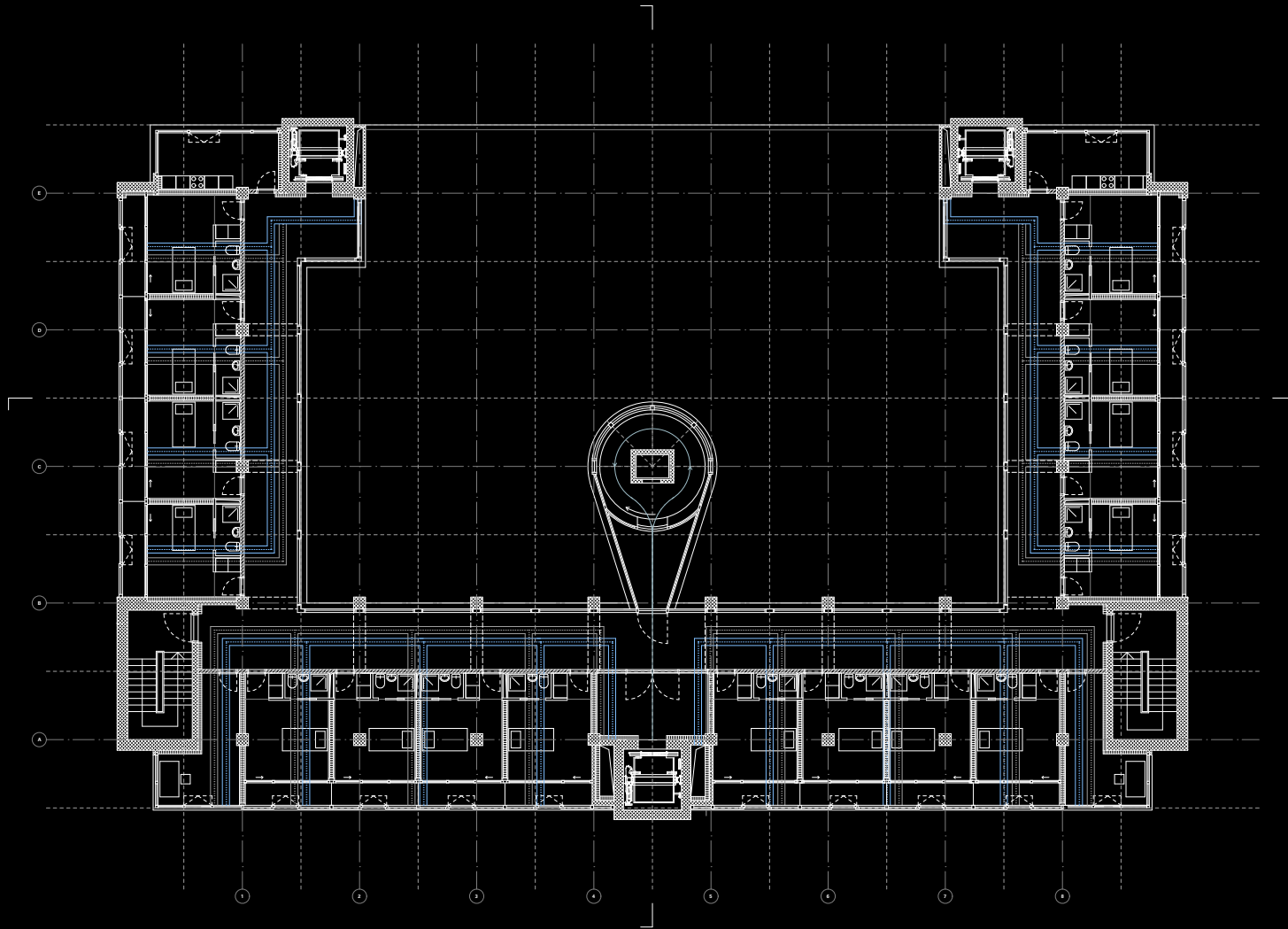

floors 11-13.
PLAN

DECLIVITAS

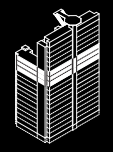

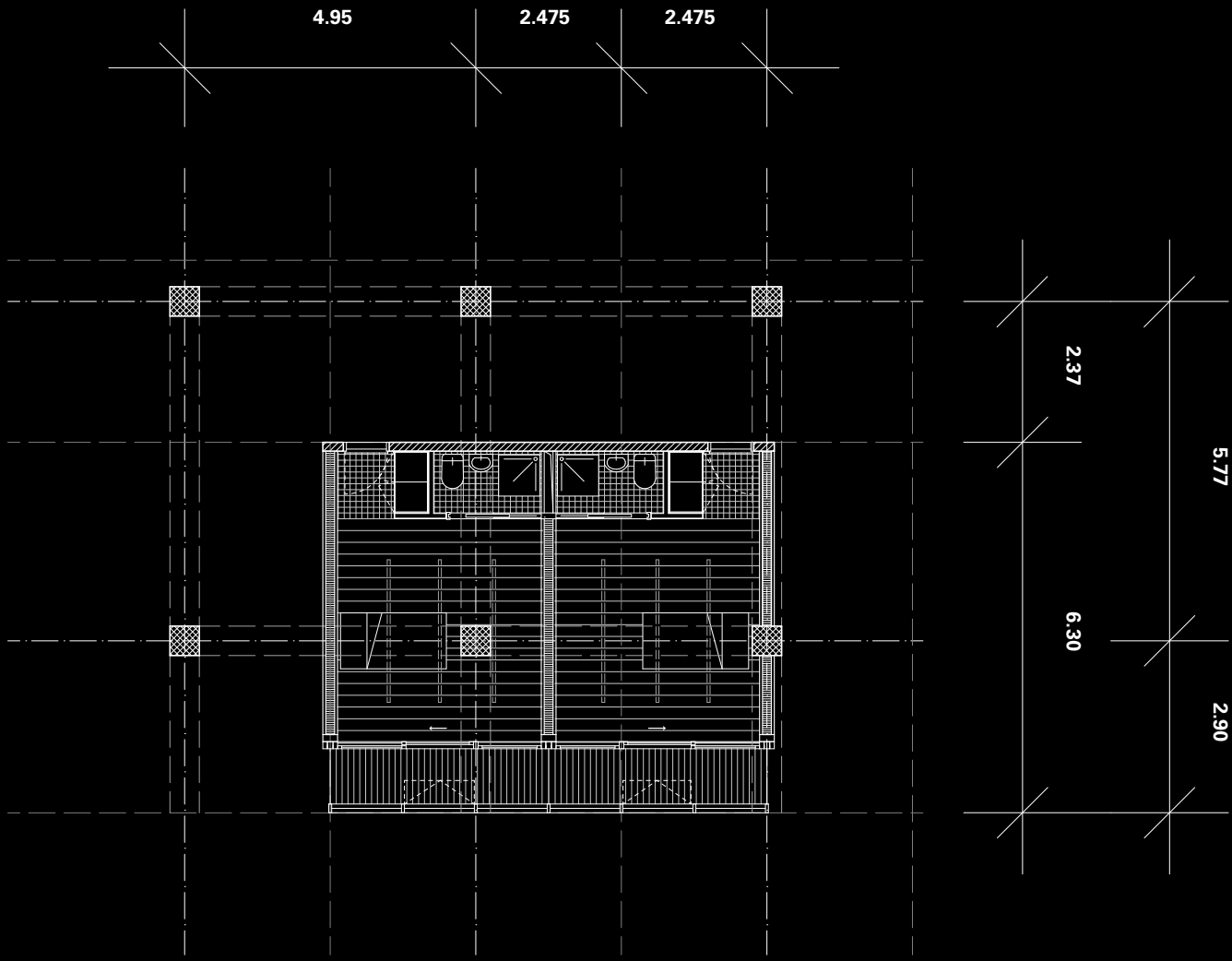

20 m² cells
PLAN
DECLIVITAS

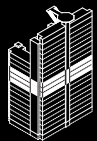
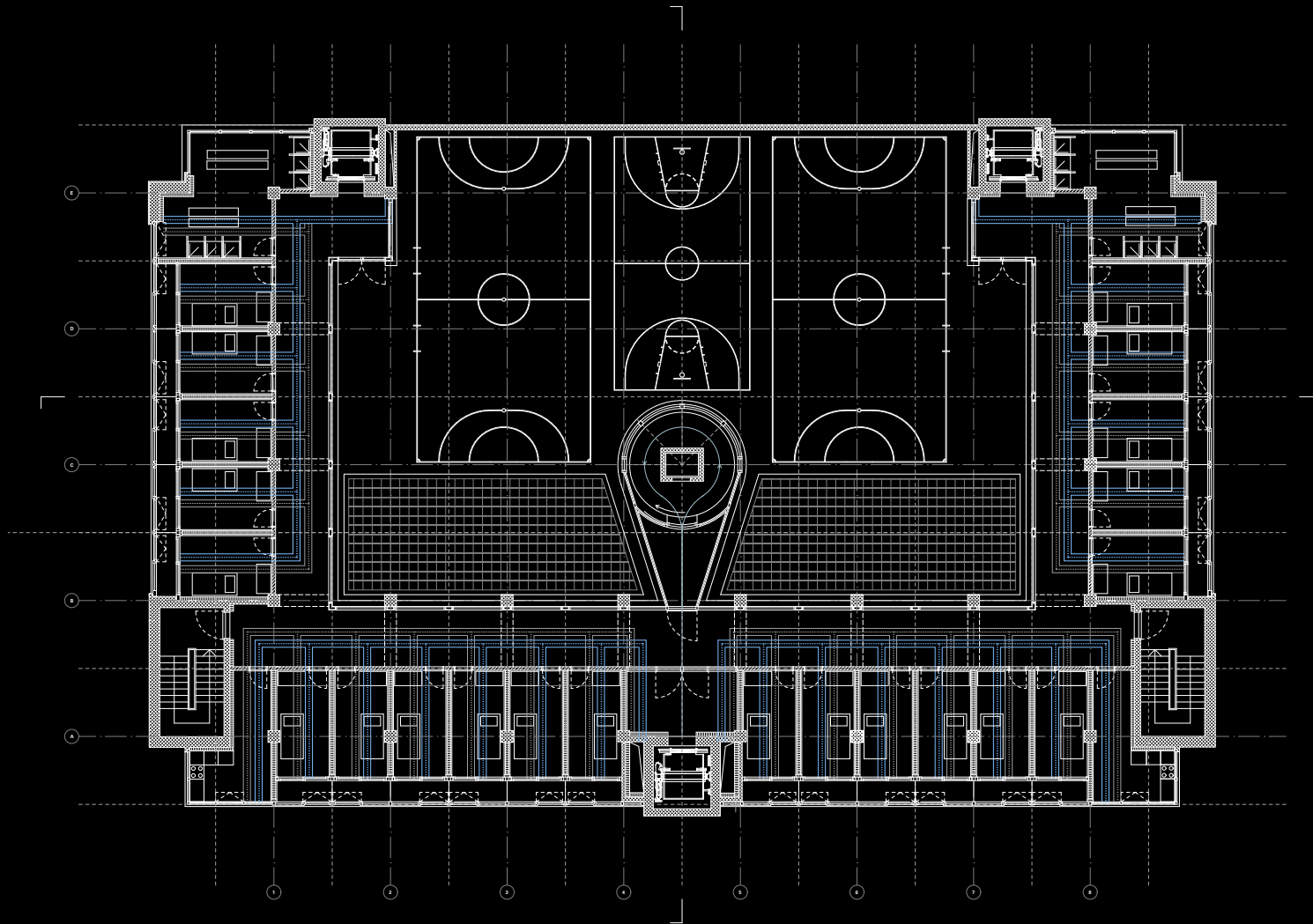

floors 8-10.
PLAN

DECLIVITAS

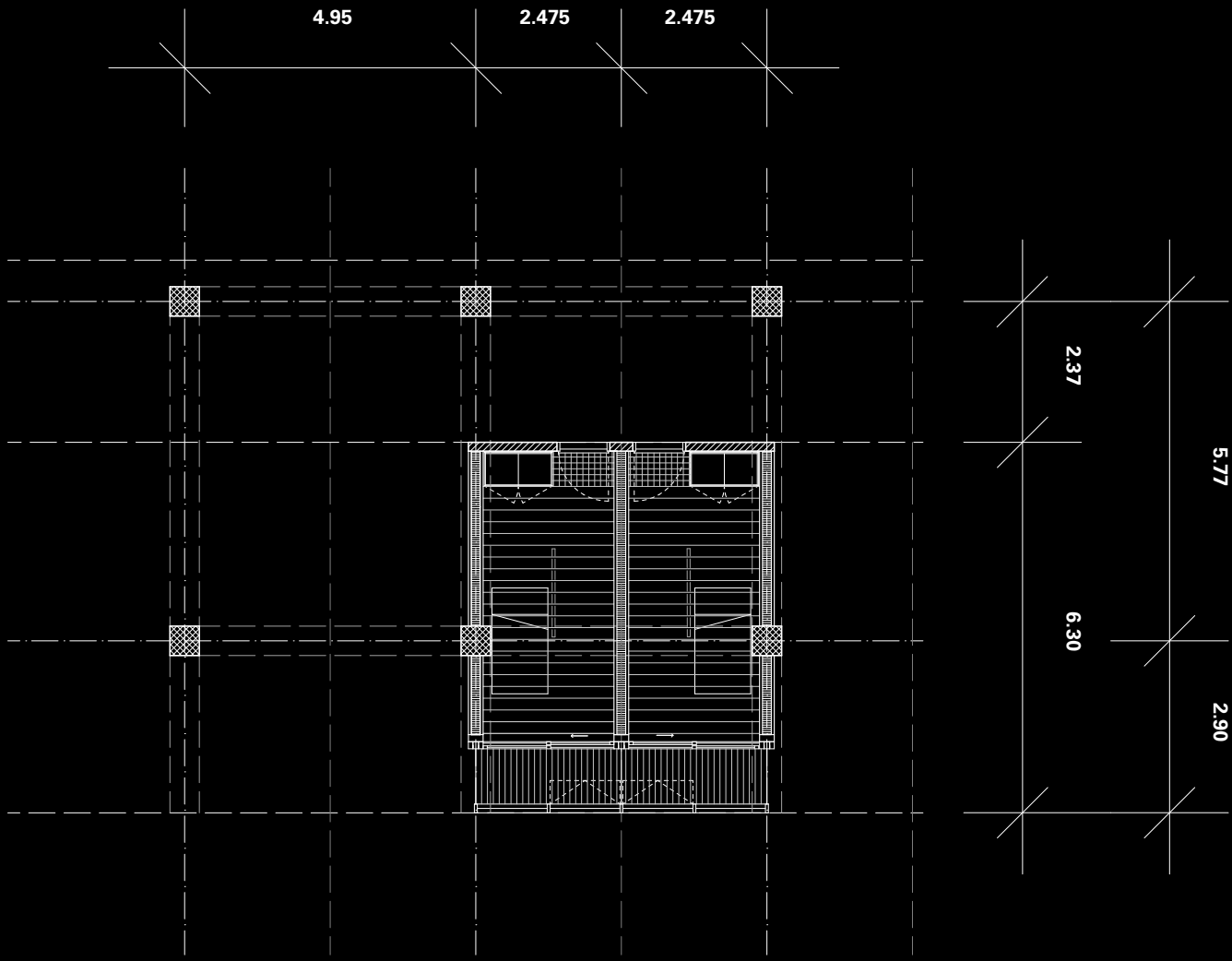

12 m² cells
 PLAN
 DECLIVITAS

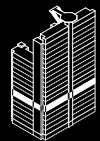
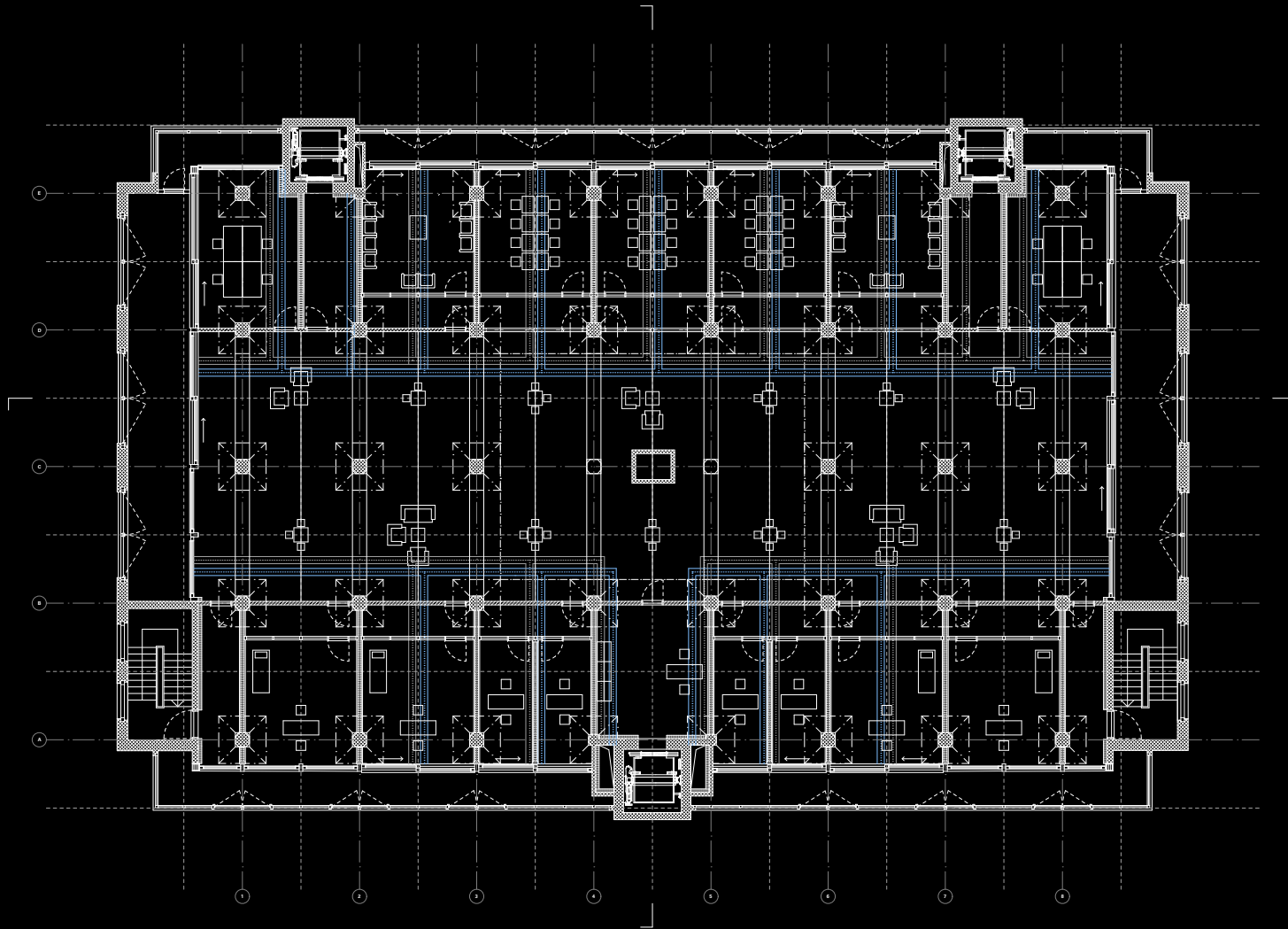

floor 5.
PLAN

DECLIVITAS

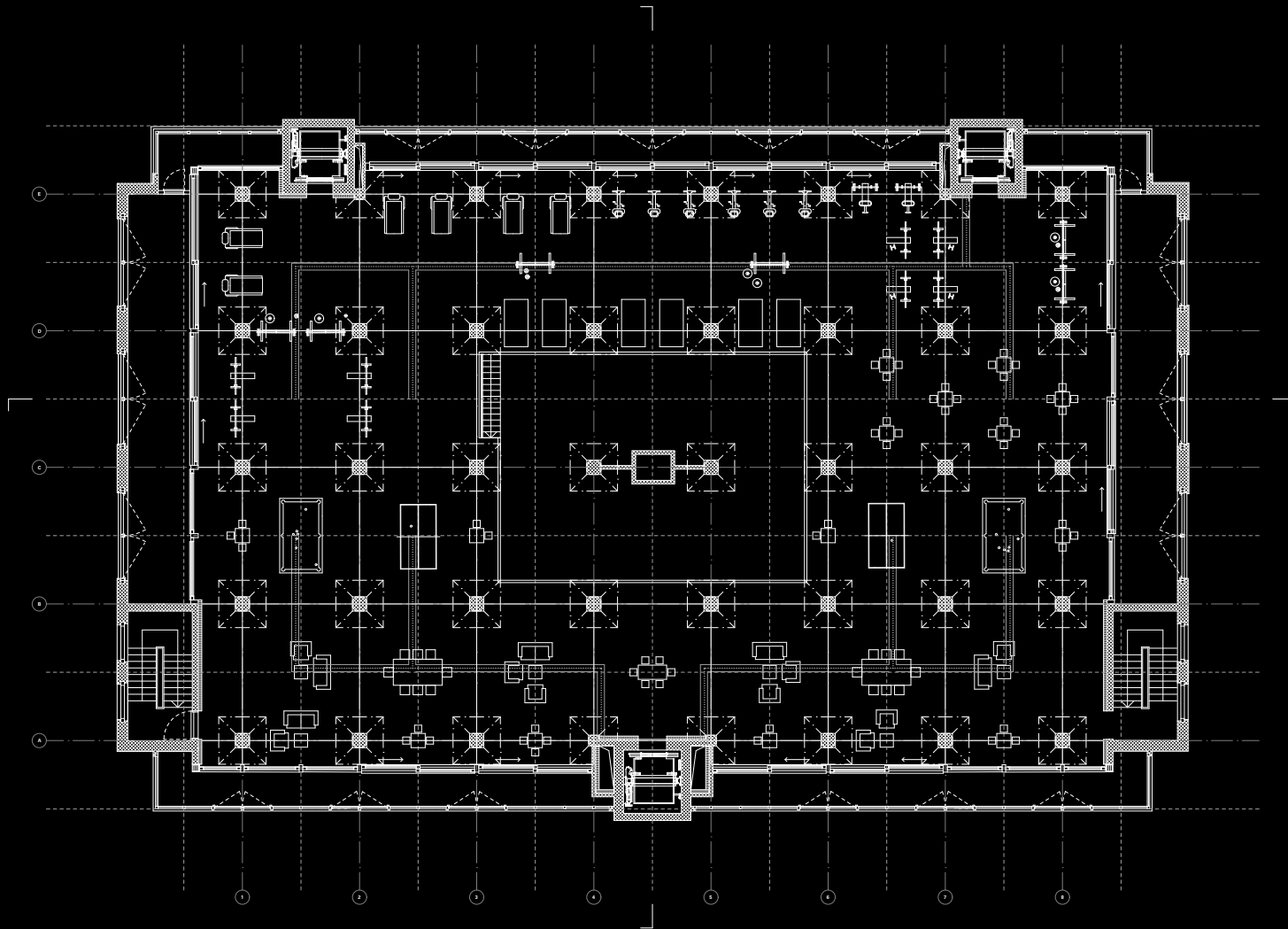

floor 4.
PLAN

DECLIVITAS

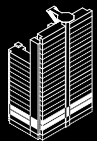
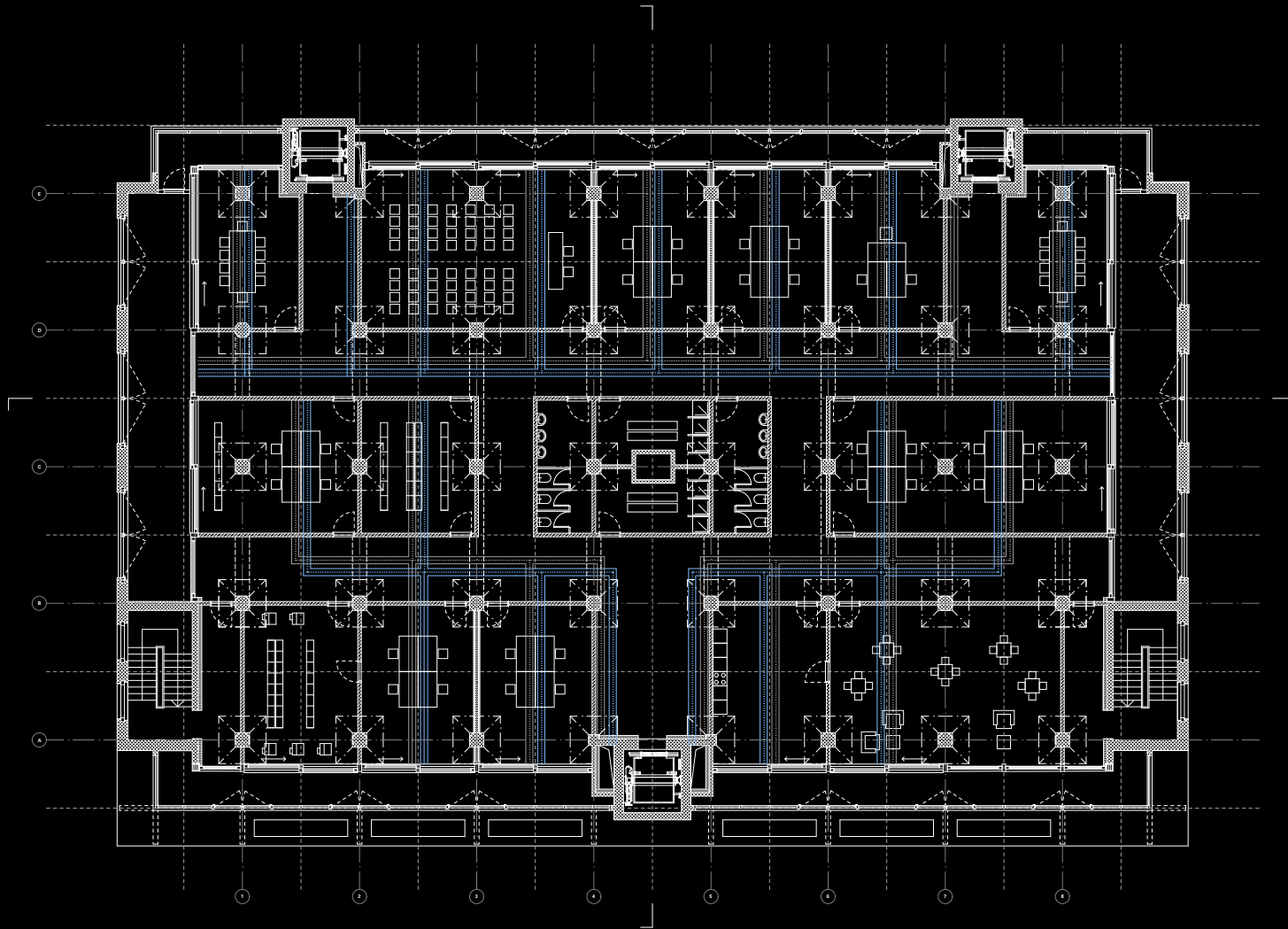

floors 1-2.
PLAN

DECLIVITAS

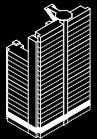
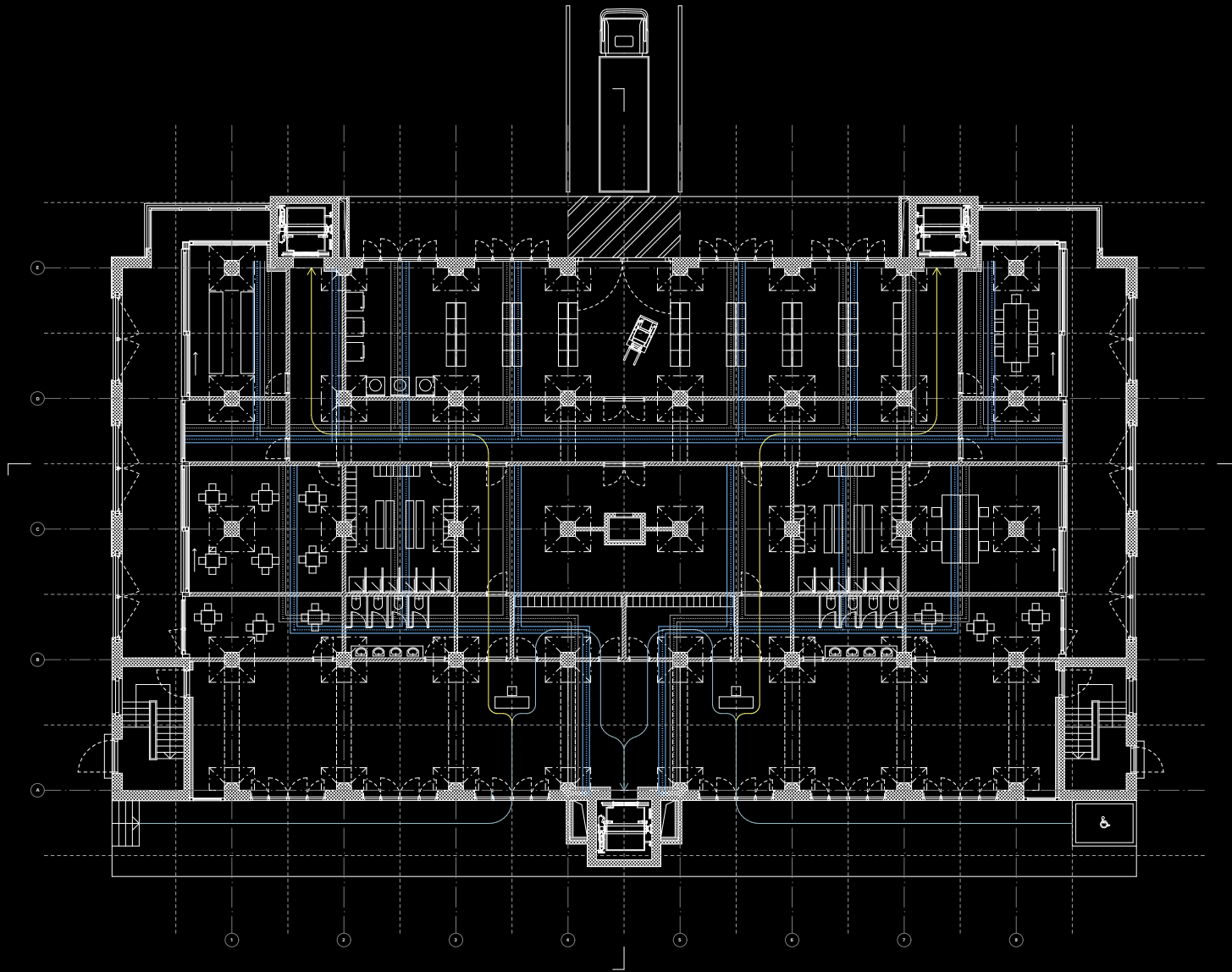

floor 0.
PLAN

DECLIVITAS

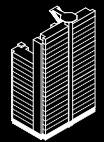
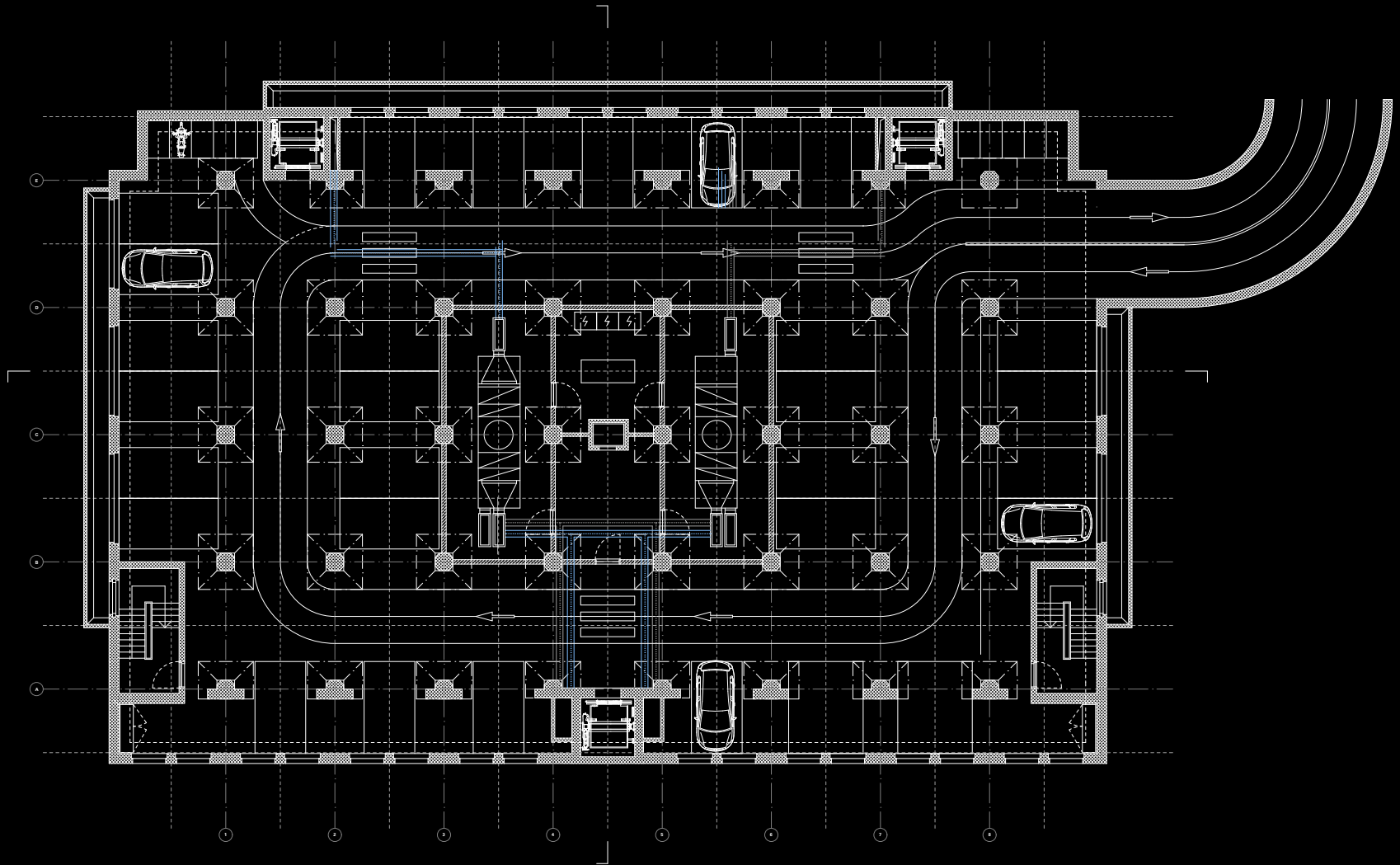

floor -1.
PLAN

DECLIVITAS

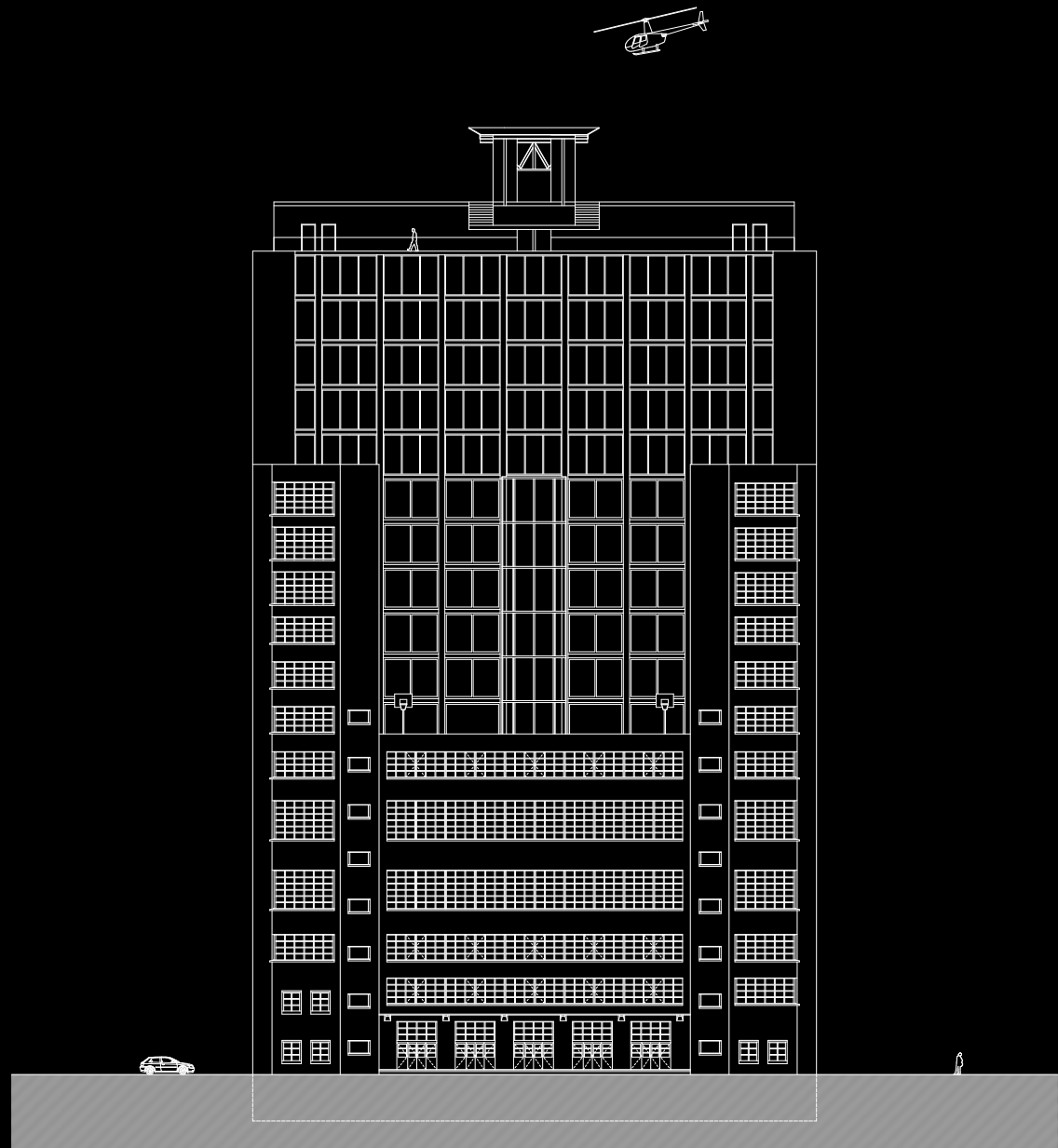

east façade
ELEVATION
DECLIVITAS

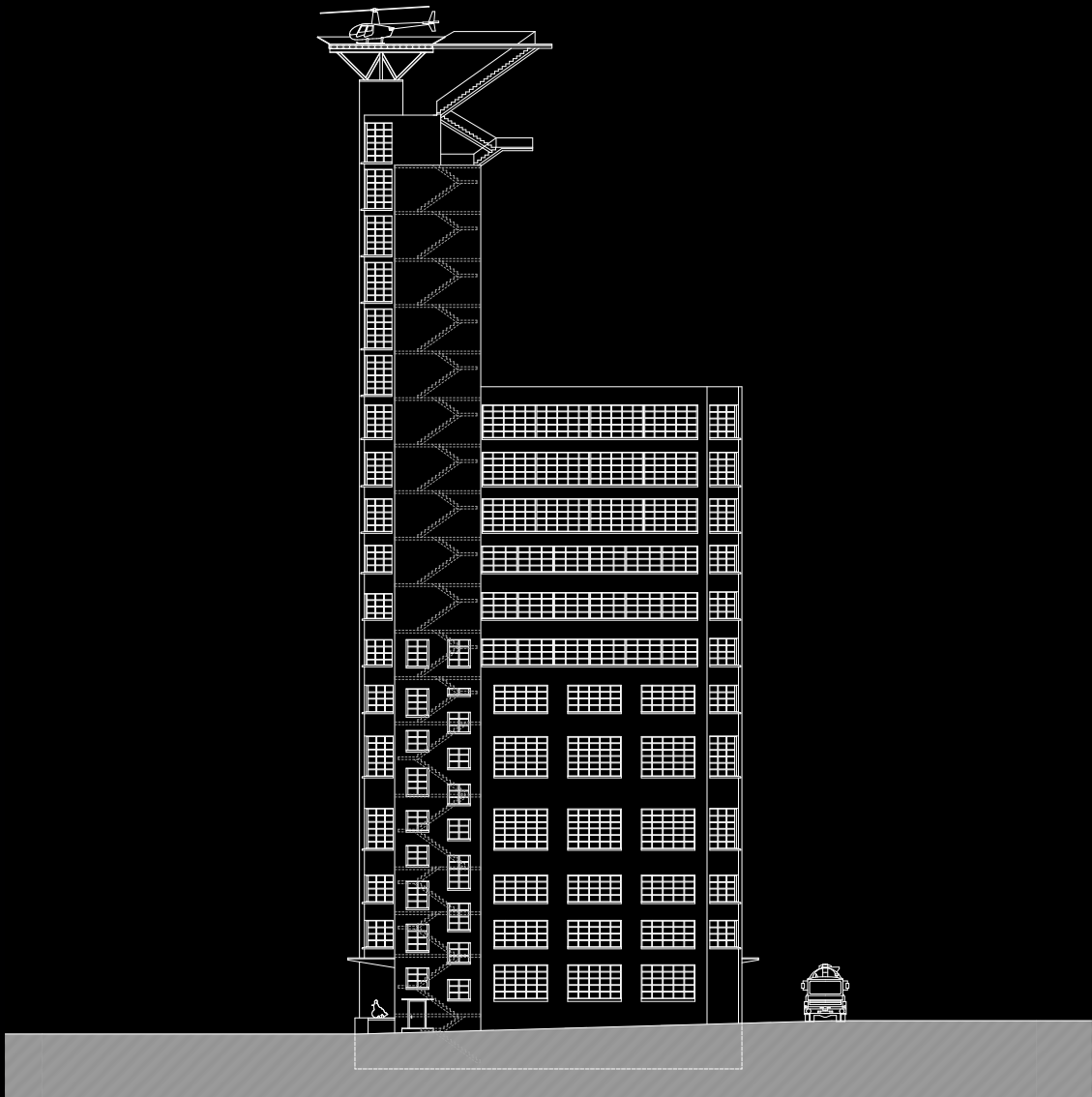

south façade
ELEVATION

DECLIVITAS

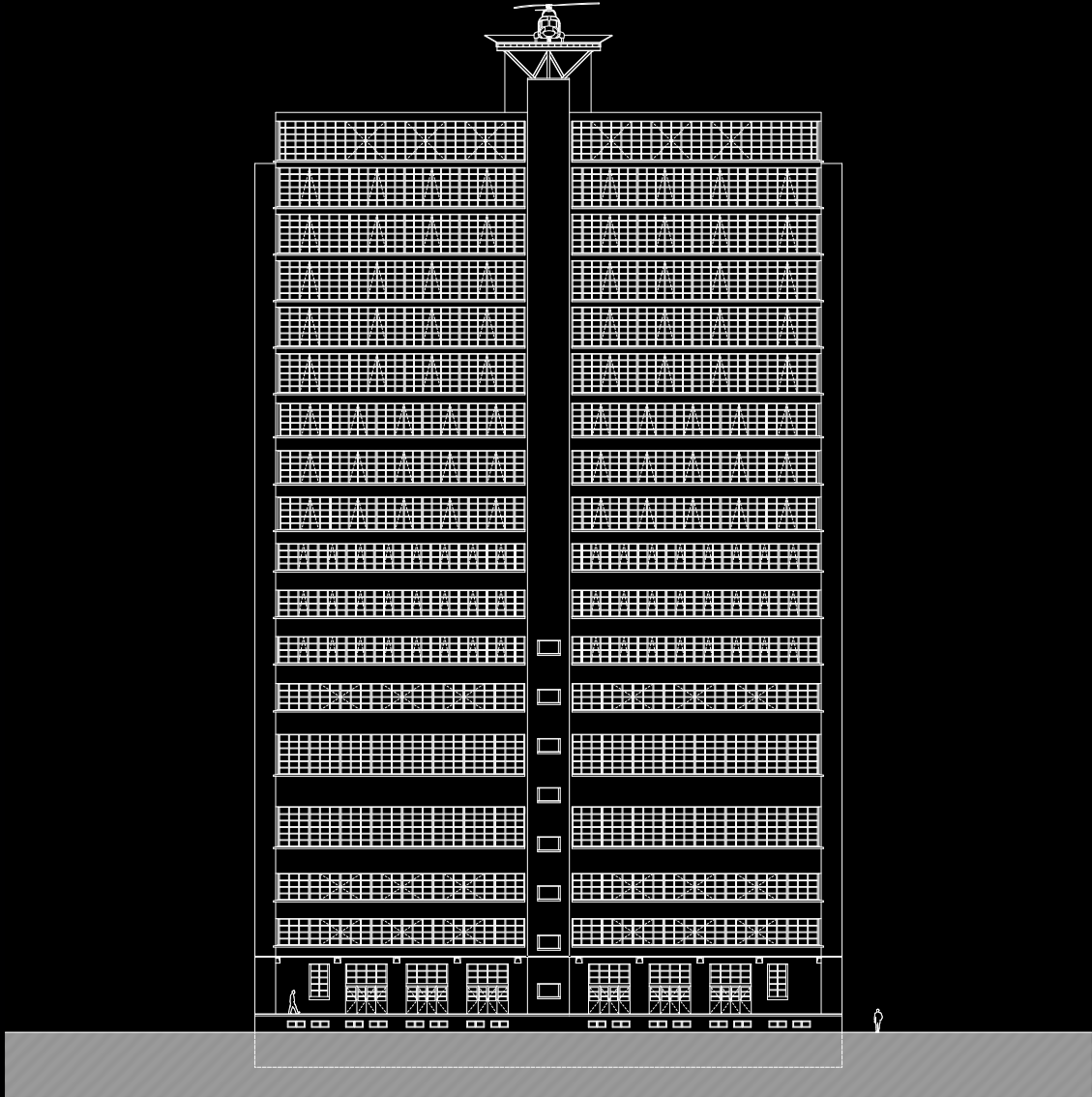

west façade
ELEVATION
DECLIVITAS



west façade

ELEVATION IMAGE

DECLIVITAS



CLICK HERE

life
MOVIE
DECLIVITAS