



# ILAC

INTERNATIONAL LOBBY ACCELERATOR COMPLEX

**LUCA MEYER**

Master Thesis HS20  
VOLUPTAS Chair Charbonnet / Heiz ETHZ

I

SUPERNATIONAL GOVERNANCE

Over the last hundred years, Geneva has developed into an international, global HUB that is a model for liberal capitalism. In addition to the area of international organizations on the west coast, a conglomerate of complementary businesses is located in the old town.

Switzerland, as a lean state without natural resources but with a booming economy, low taxes and little regulation, is an *El Dorado* for the resource companies and their shareholders that have settled in Geneva over the last twenty years. A secondary sector has developed around the commodity trading activities, ranging from financing to insurance and consulting.

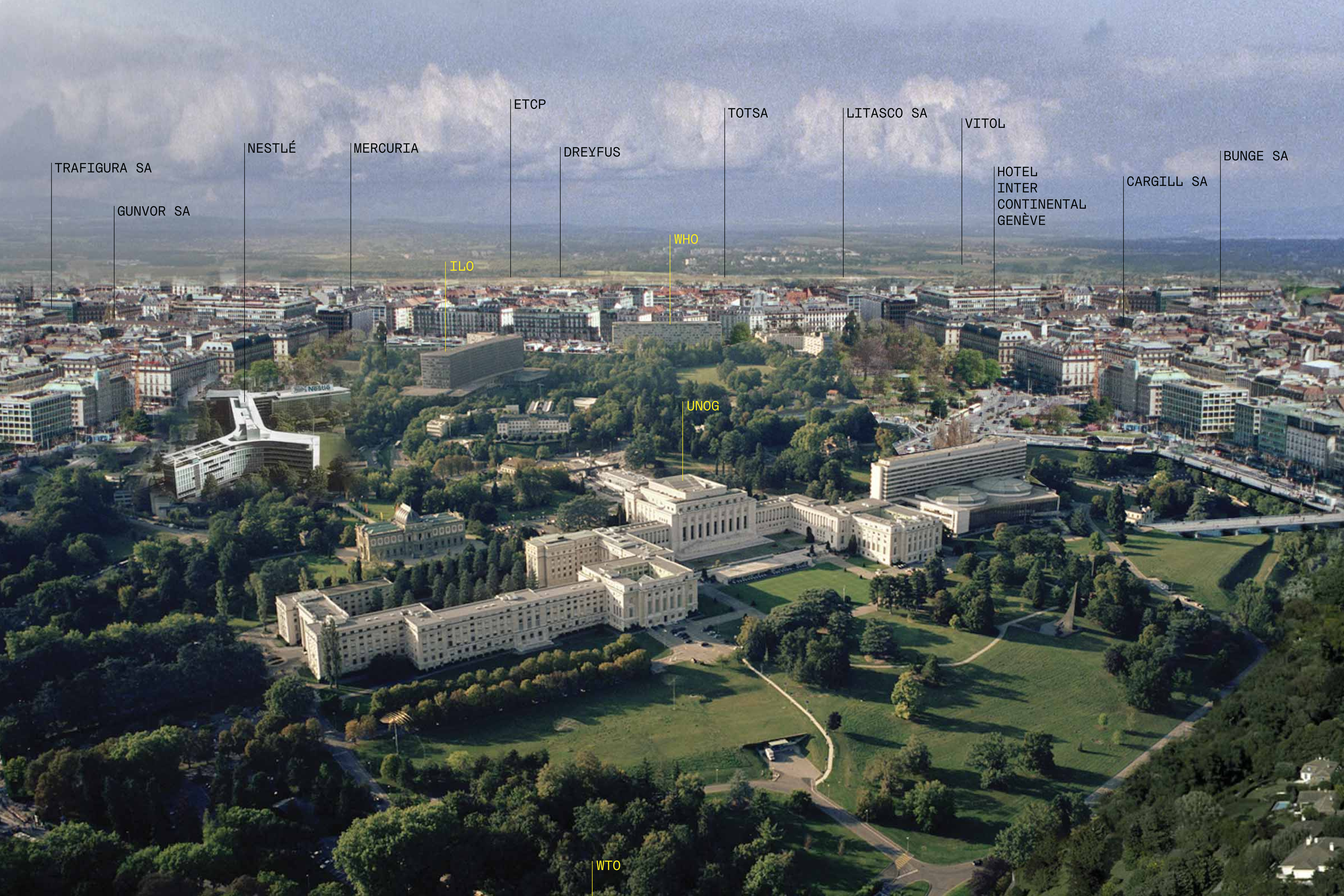

TRAFIGURA SA

GUNVOR SA

NESTLÉ

MERCURIA

ILO

ETCP

DREYFUS

WHO

UNOG

TOTSA

LITASCO SA

VITOL

HOTEL  
INTER  
CONTINENTAL  
GENÈVE

CARGILL SA

BUNGE SA

WTO

When considering only the multilateral organizations as shapers of the legal situation, one must not forget that the surrounding supranational governmental apparatuses are not considered in the decision-making process.

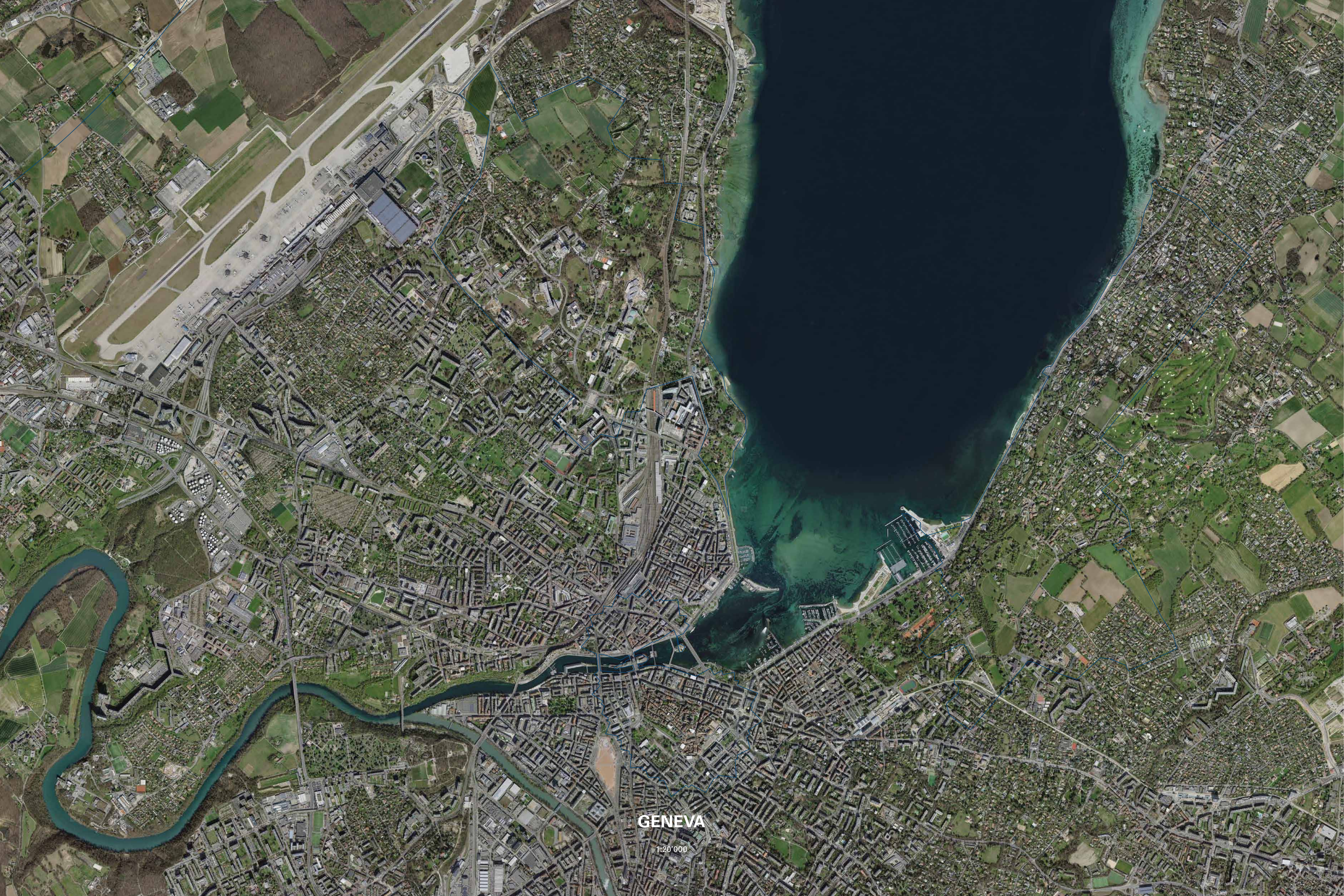

GENEVA

1:20'000



**INTERNATIONAL ORGANISATIONS**

**INTERNATIONAL ORGANISATIONS**

Jardin des Nations

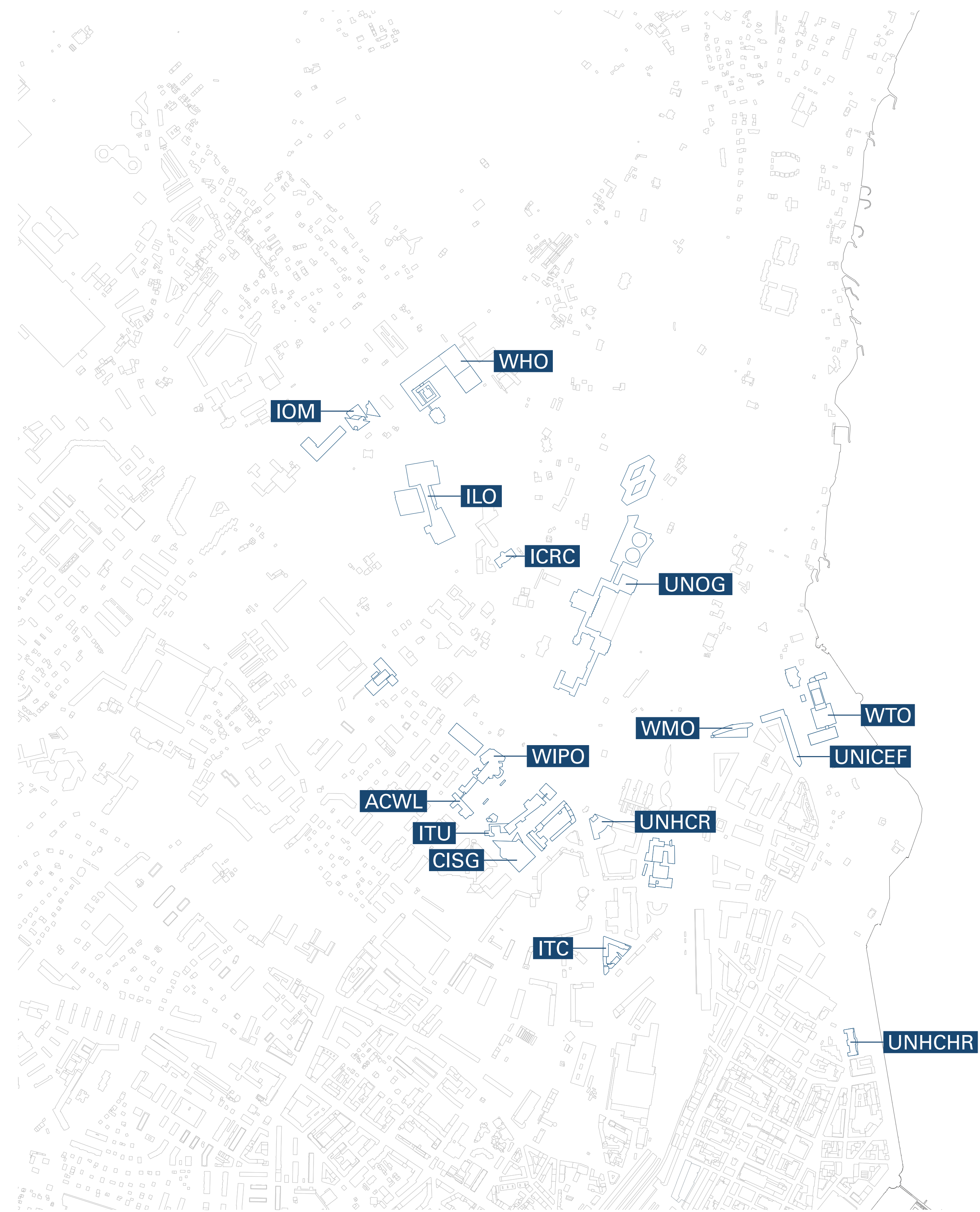

## INTERNATIONAL ORGANISATIONS

Shows the Organisations at Jardin des Nations



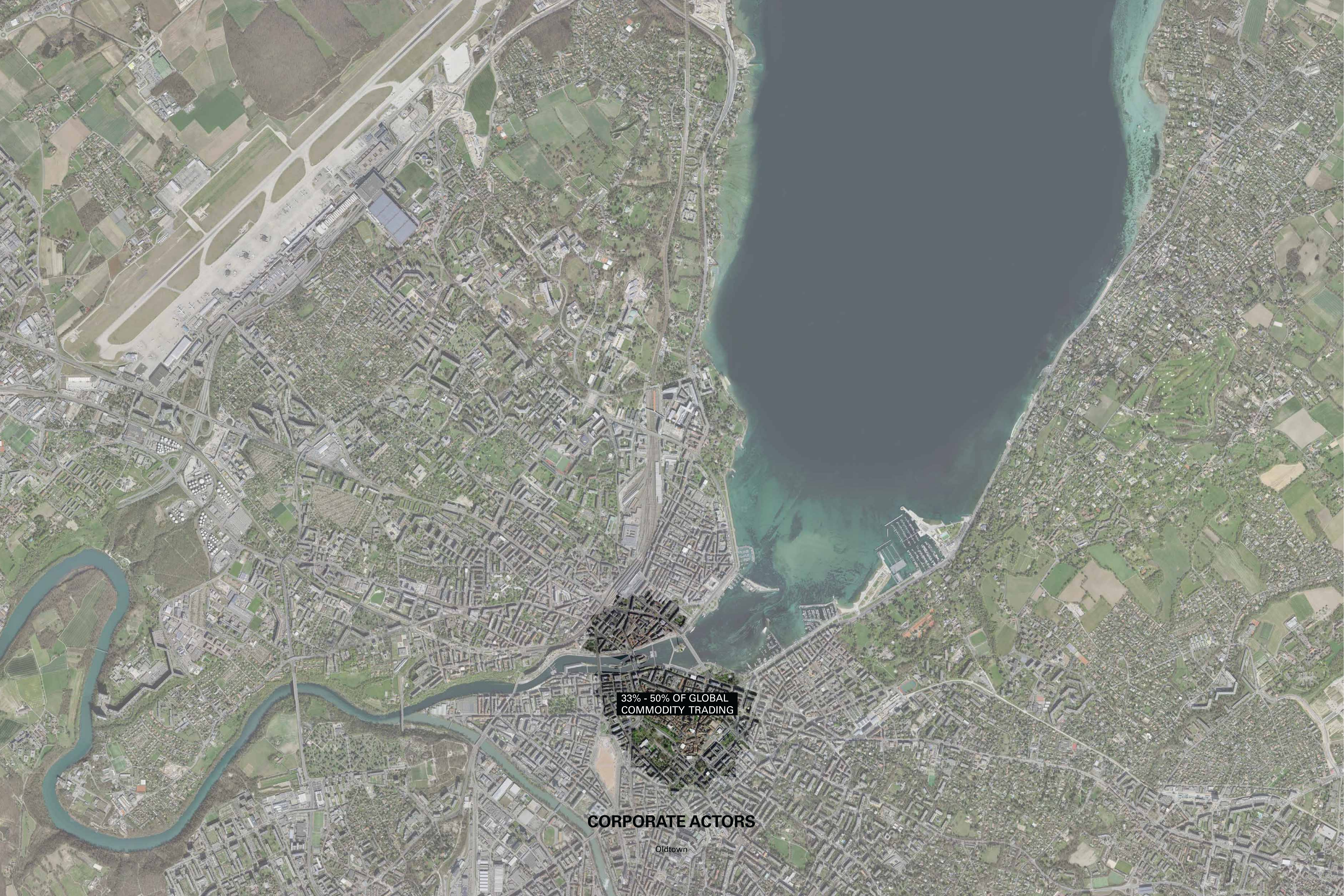

33% - 50% OF GLOBAL  
COMMODITY TRADING

**CORPORATE ACTORS**

Oldtown

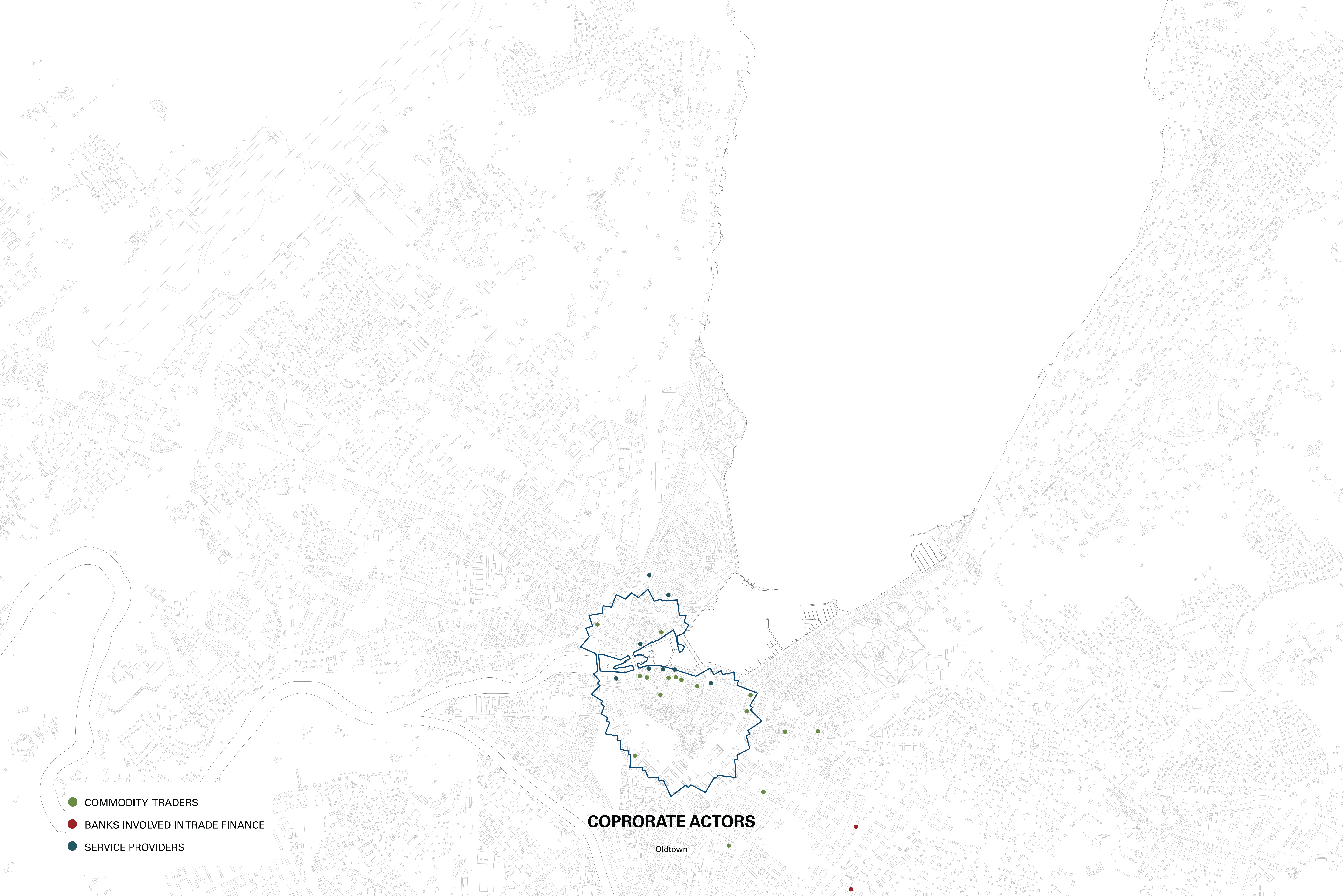

**COPORATE ACTORS**

Oldtown

- COMMODITY TRADERS
- BANKS INVOLVED IN TRADE FINANCE
- SERVICE PROVIDERS

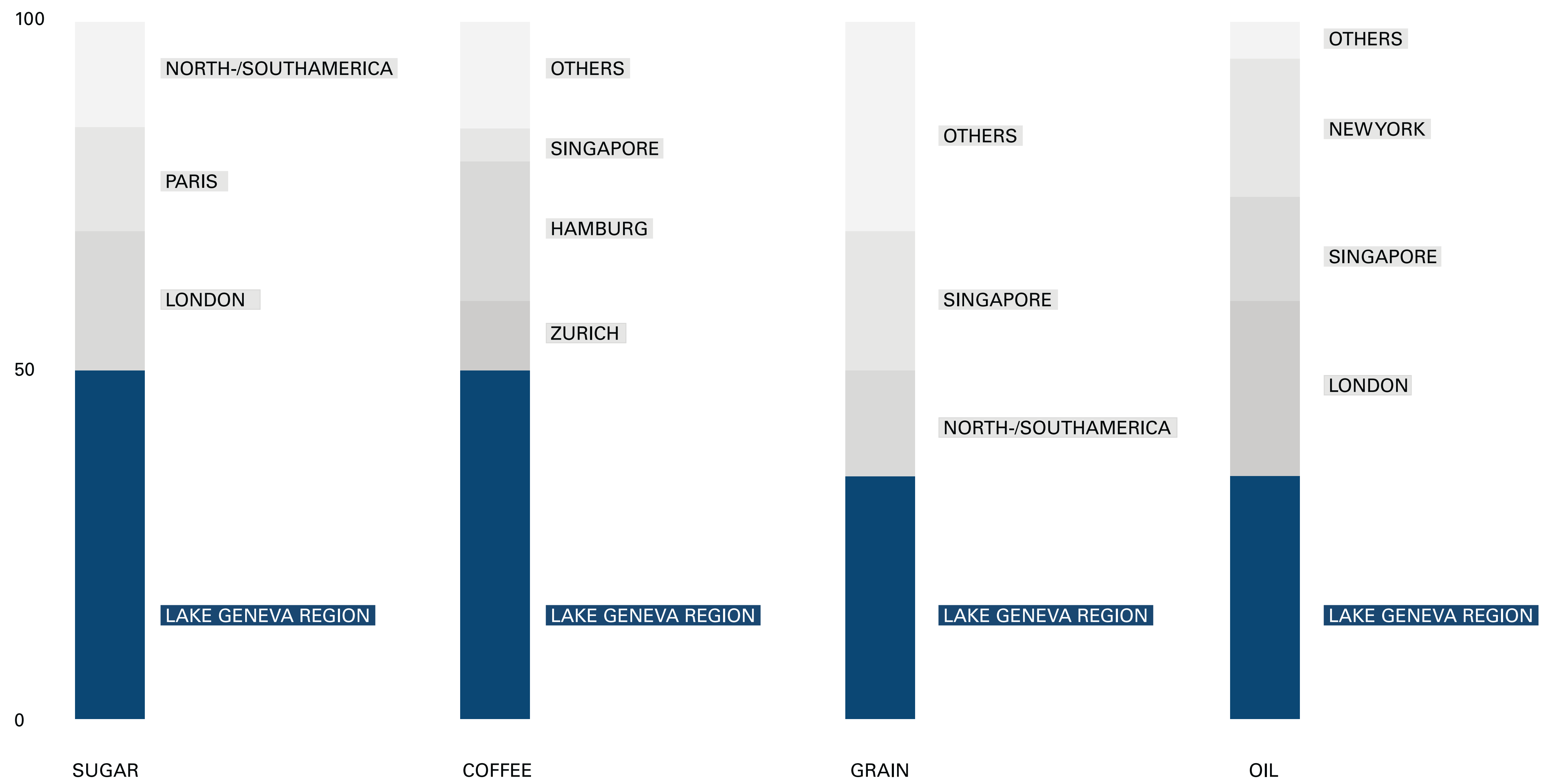

**GENEVAS SHARE IN GLOBAL TRADE**

Source: GTSA (2013)



## CORPORATE ACTORS

the complementary businesses in the city centre



VILLAS OWNED BY THE  
SHAREHOLDERS OF THE  
TRADING COMPANIES

DOMICILE OF 25% OF THE  
RICHEST SWISS RESIDENTS

MOST EXPENSIVE LANDPRICE  
IN SWITZERLAND

**SHAREHOLDERS**  
Cologne



## SHAREHOLDERS

Cologne is home to the CEO's

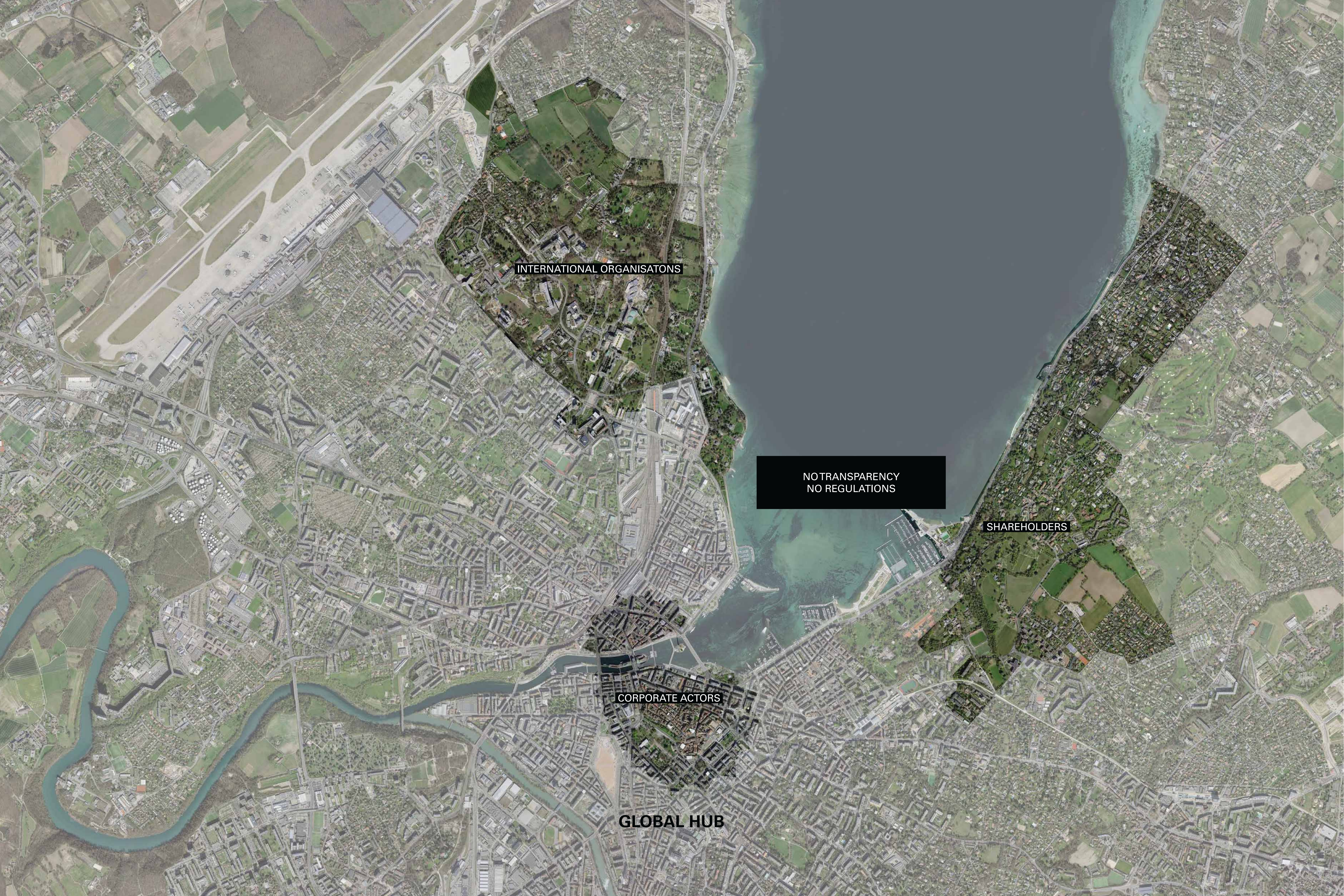

INTERNATIONAL ORGANISATIONS

NO TRANSPARENCY  
NO REGULATIONS

SHAREHOLDERS

CORPORATE ACTORS

GLOBAL HUB

Despite the many criticisms and the demand for more transparency, inexplicably Switzerland does not want any special regulation for the commodity trading sector. Even if the Swiss Money Laundering Act is clearly formulated since 2011, commodity trading is still not subject to the Money Laundering Act like the financial sector. Is it negligence or political will? The explicit reasons for this remain speculation, but it's fact that their lobbying helped shape the legislative work. They met with the Minister of Economic Affairs, Johann Schneider-Ammann and have been spared from new transparency regulations to this day.





## MEETING WITH THE COUNCILLOR

Councillor Schneider-Amman and GTSA Vide-President Nicolas Tamari (2014)

Lobby (v.)

“seek to influence legislation” (originally by frequenting the lobby of a legislature, to solicit members), 1826, American English, from lobby (n.) in the political sense.

ETIMOLOGY, [ONLINE ETYMOLOGY DICTIONARY](#) (2020)

Lobby (n.)

means “large entrance hall in a public building” and is from 1590s; in reference to the House of Commons from 1630s. Political sense of “those who seek to influence legislation” is attested by 1790s in American English, in reference to the custom of influence-seekers gathering in the *large entrance-halls* outside legislative chambers.

ETIMOLOGY, [ONLINE ETYMOLOGY DICTIONARY](#) (2020)

II

INVISIBLE NETWORKS



The strip from the Avenue de France, to the Pont du Mont Blanc and the Rampe de Cologny, represents a speculative mini-cosmos of an opaque global economic model, controlled and shaped by invisible networks of transnational private interests. Observing the situation in Geneva across the strip to the UN, provides insights on how informal spaces connect different areas into a symbiotic and fast acting Ensemble.

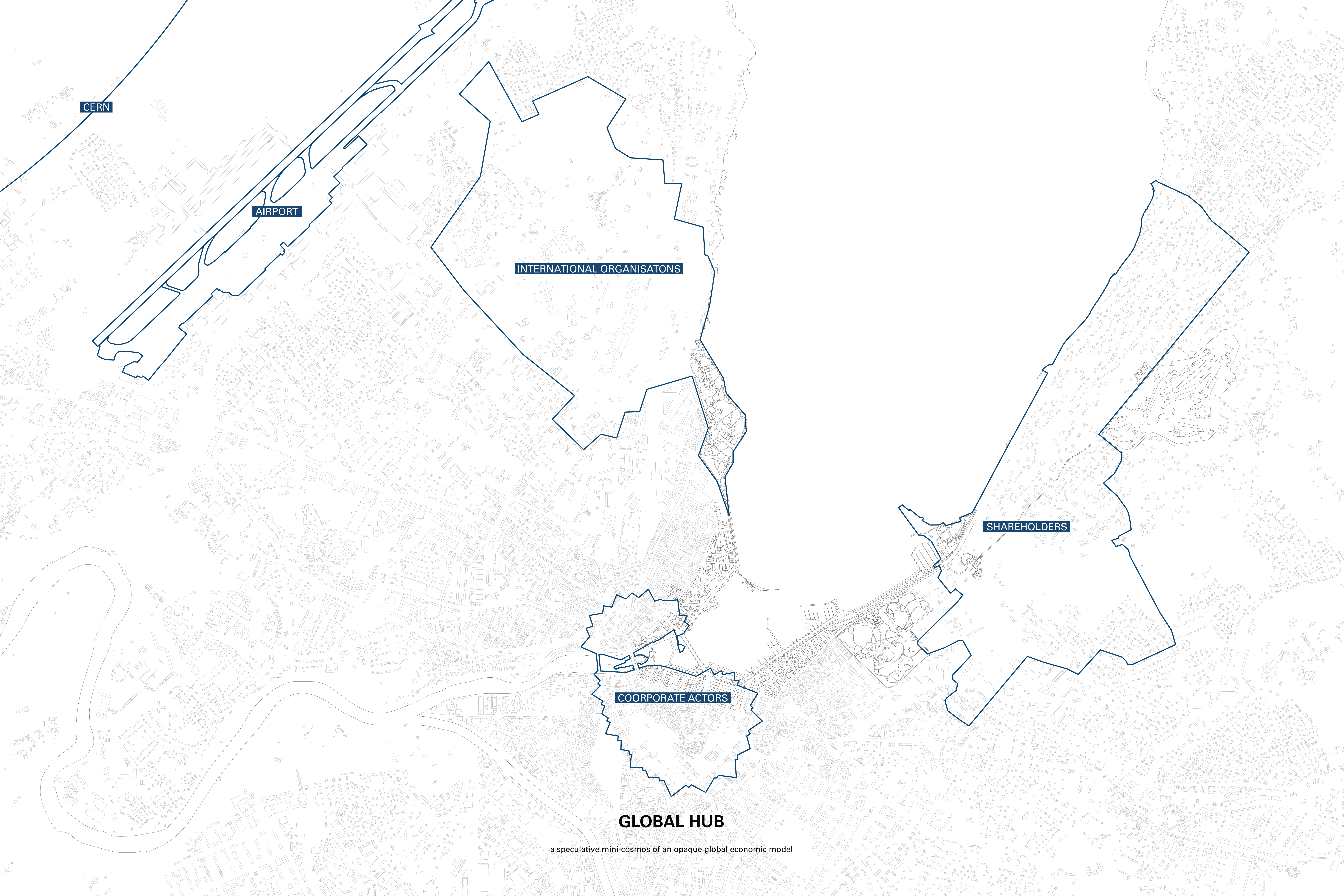

CERN

AIRPORT

INTERNATIONAL ORGANISATIONS

SHAREHOLDERS

CORPORATE ACTORS

GLOBAL HUB

a speculative mini-cosmos of an opaque global economic model



**INFORMAL STRIP**

the strip connects different areas into an ensemble





**ENTERTAINMENT**

casino, hotel, bath, restaurant



**UNDERPASS**

Grand Casino Noga Hilton



**PARCS**

informal strip



**PROMENADE**

informal strip

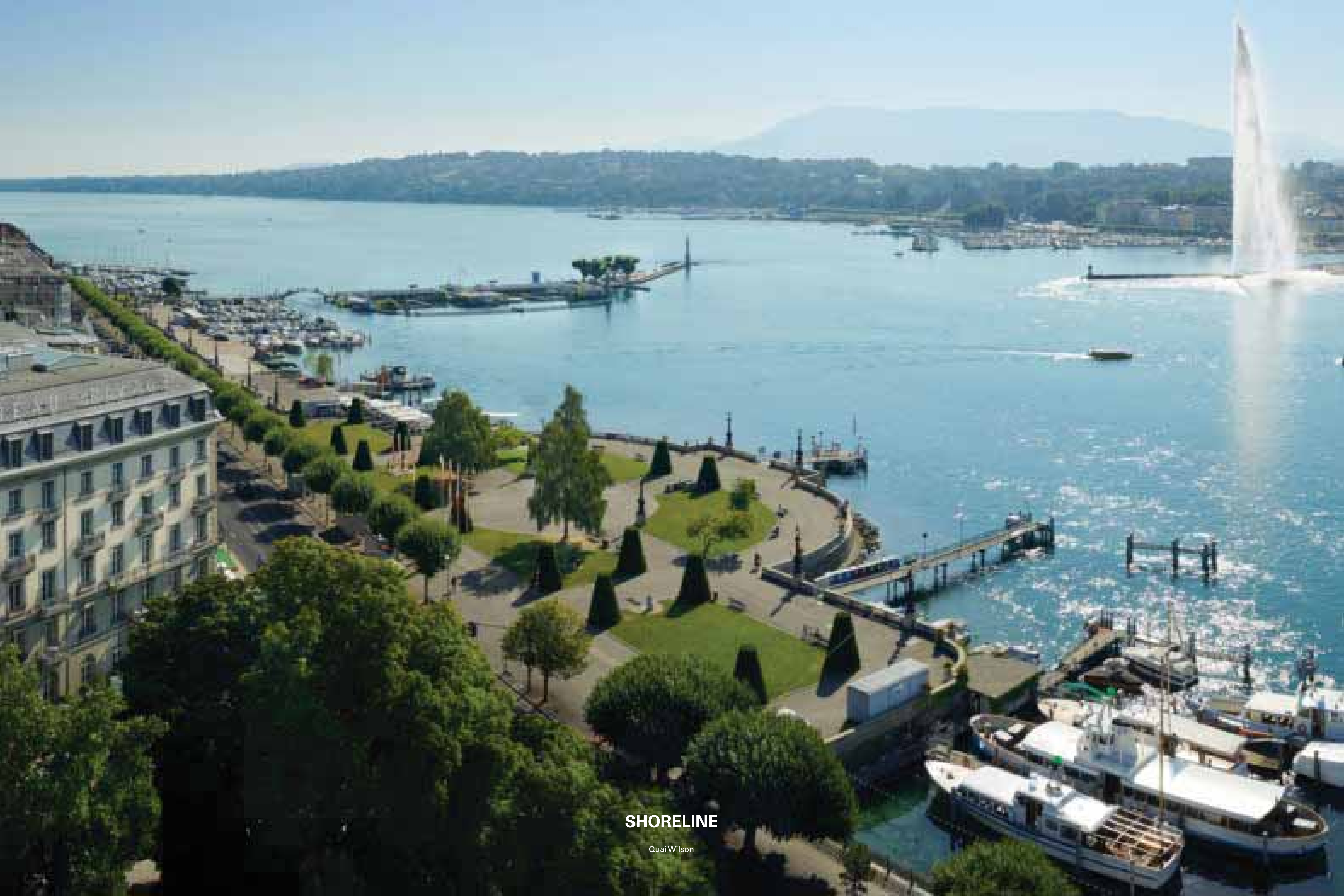

## SHORELINE

Quai Wilson



**COMPLEMENTARY BUSINESSES**

informal strip



OFFICE

Rosneft SA



**GOLF CLUB**

informal strip





**HARBOR**

informal strip

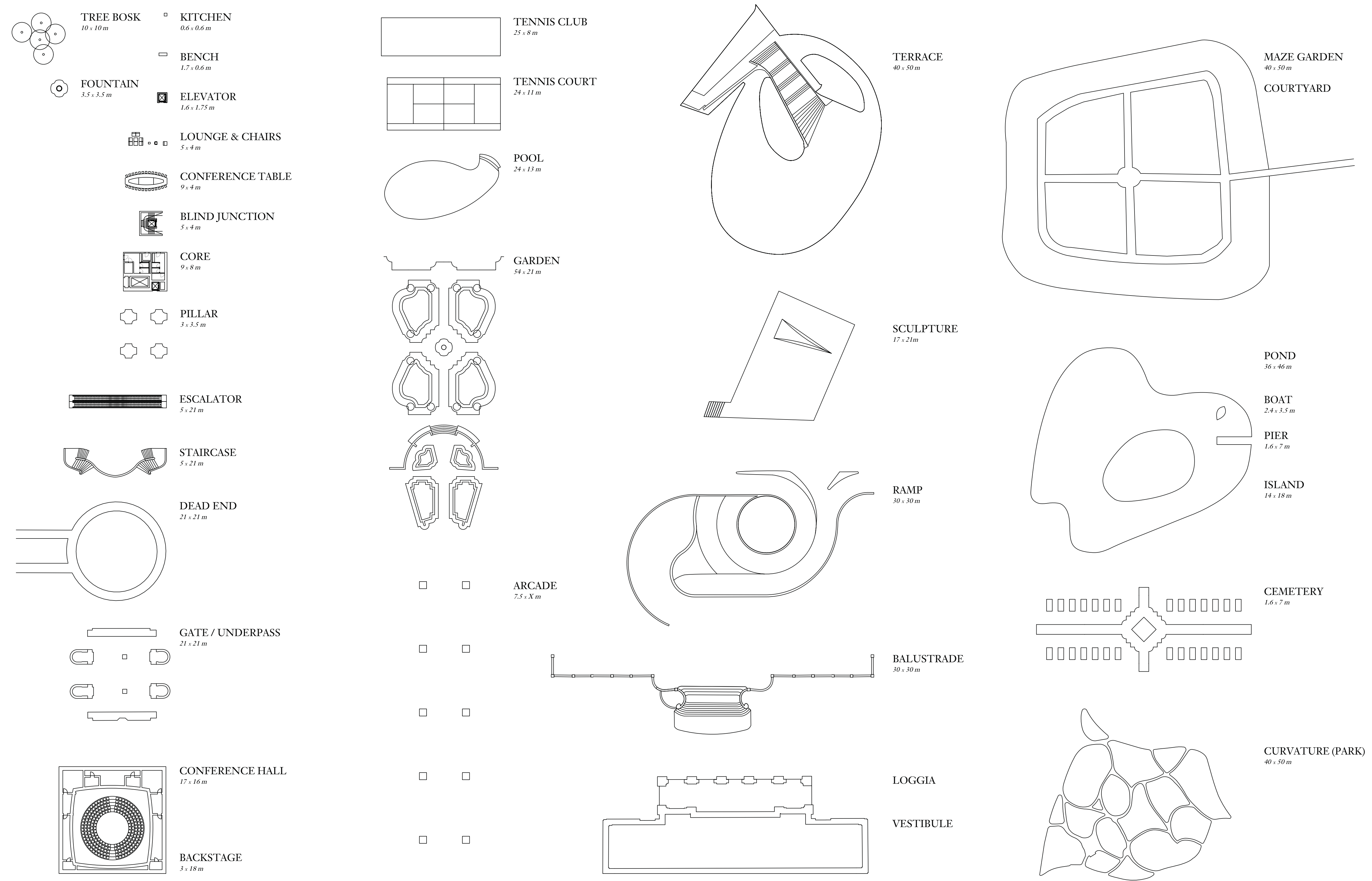

# INVENTORY

informal spaces



## THE LOBBY ACCELERATOR

The current UN apparatus is too inefficient, too slow and too centralized to enforce its provisions successfully while the isolation of the individual organizations prevents effective implementation across organizations. Observing the situation in Geneva across the strip to the UN serves as an insight on how informal space connects different areas into a symbiotic and fast acting Ensemble.

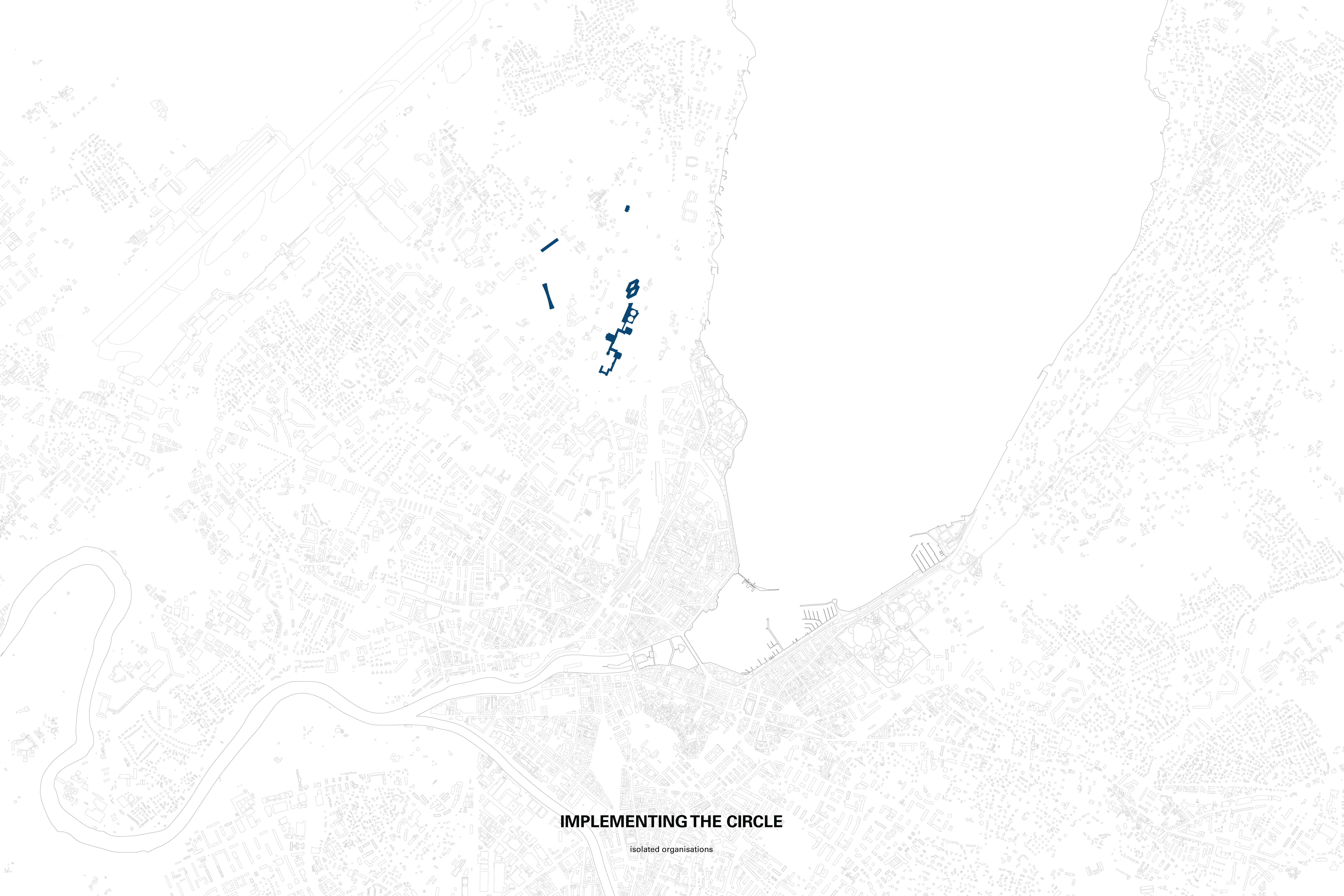

**SOUTH**

**IMPLEMENTING THE CIRCLE**

isolated organisations



## THE ACCELERATOR

implementing the speed from CERN and the will to act from GTS

The Lobby Accelerator embedded in the existing spaces at the International Organizations ensures a more efficient lobbying in a decentralized network used by diplomats, officials and the public. In this new organization, whose network generates informal nodal points due to its sheer size, legally liberated negotiations can happen and promise to speed up action and take the UN back to the center of global governance, where the decisions can have a direct impact on people's lives.

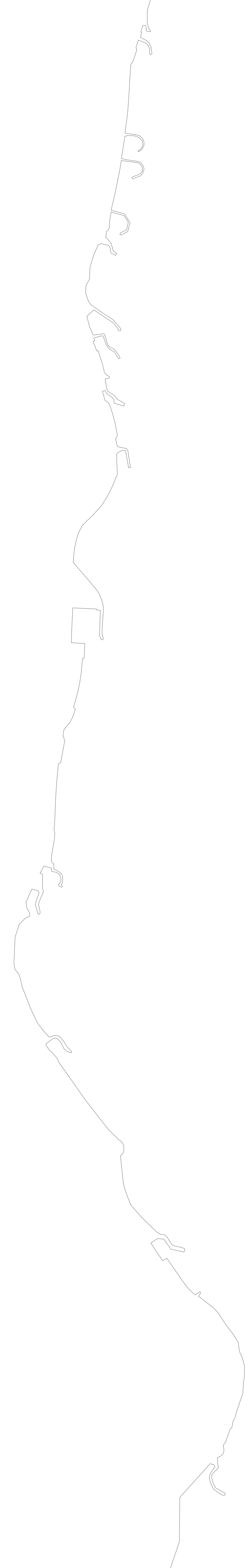
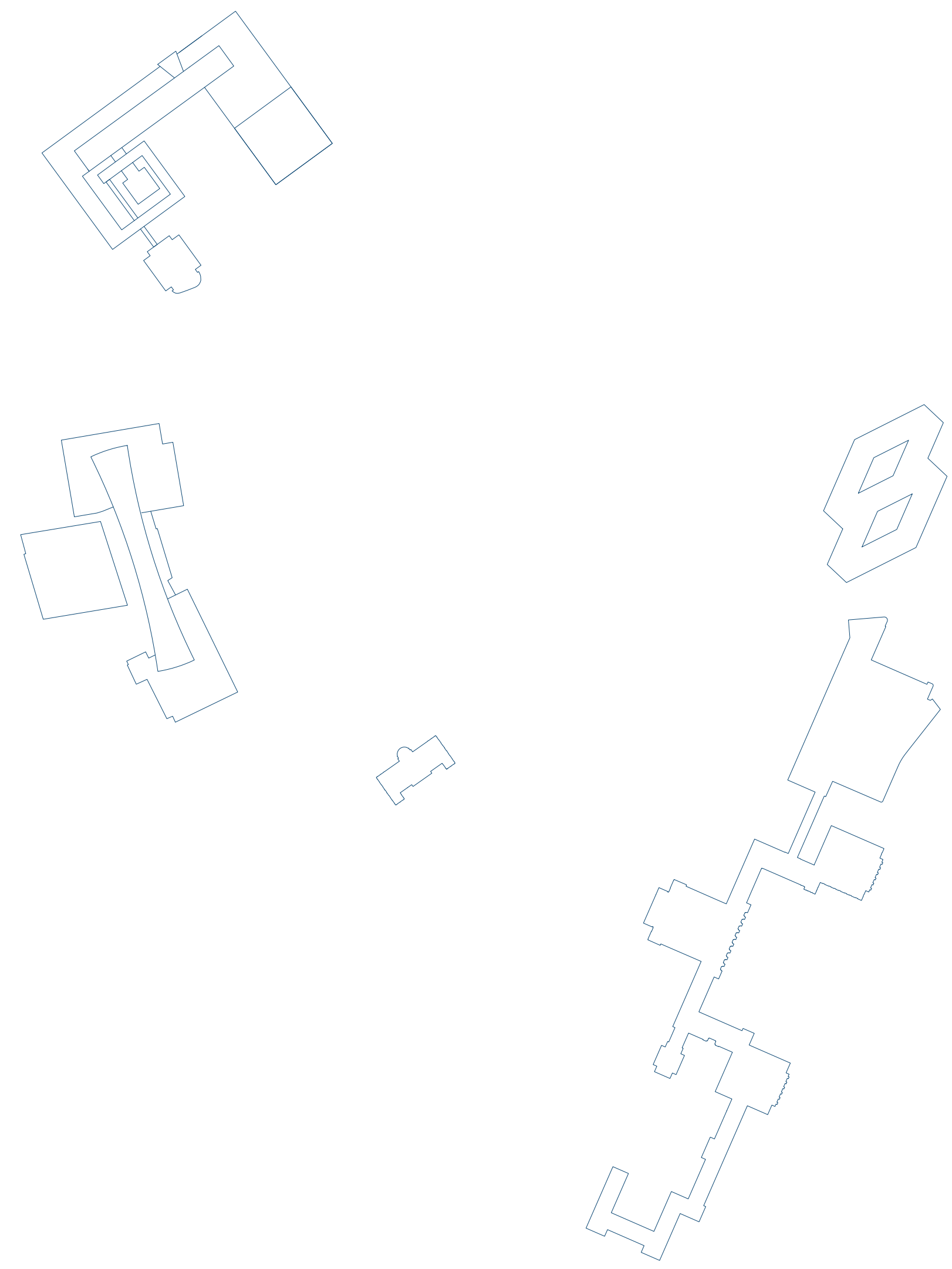

# ISOLATED ORGANISATIONS

connecting the isolated organisations into a new performing machine



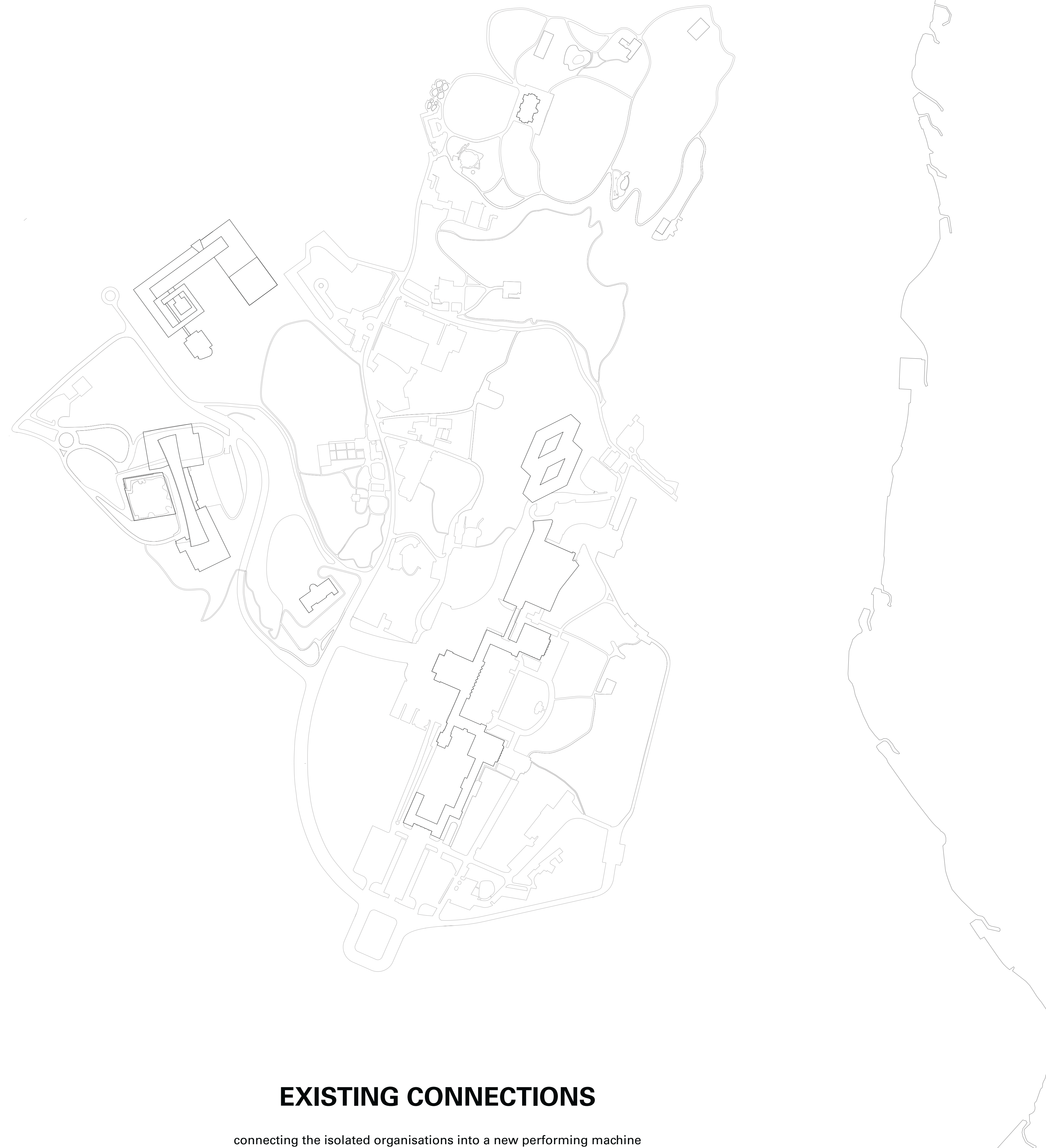



## EXISTING CORRIDORS

connecting the isolated organisations into a new performing machine

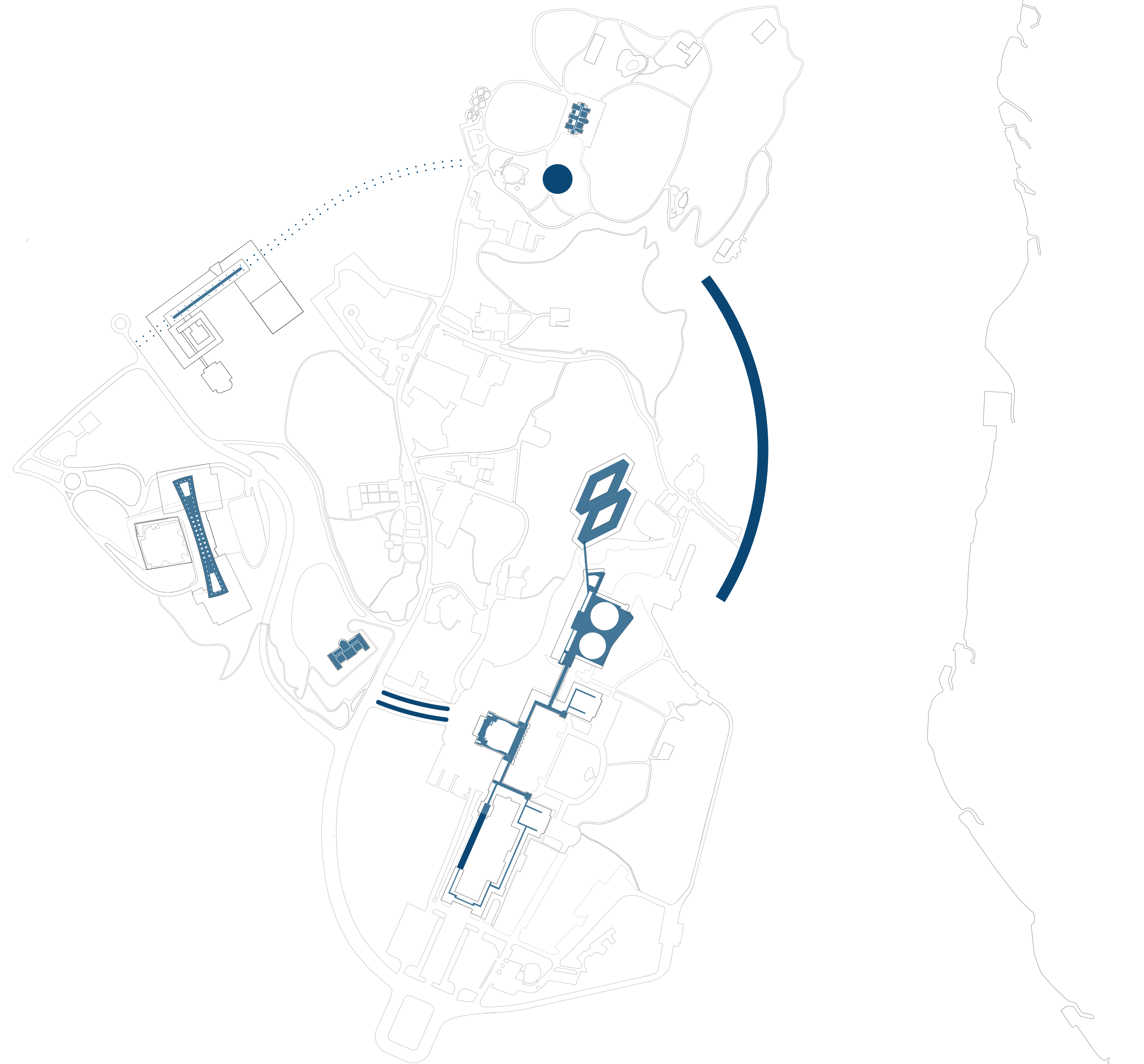

## NEW CONNECTIONS

connecting the isolated organisations into a new performing machine

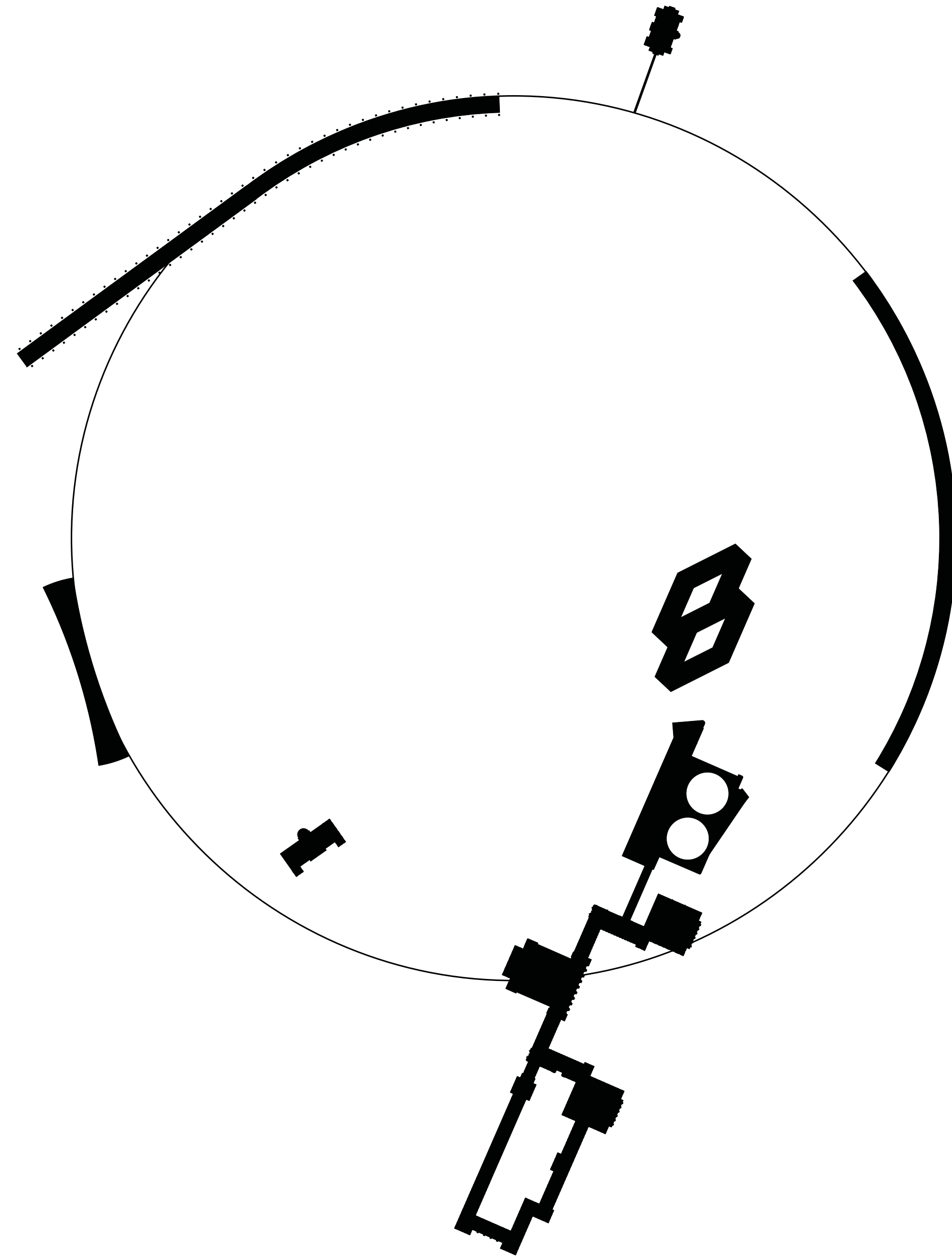

## THE LOBBY ACCELERATOR

Shows the architectural Accelerators and Decelerator at ILAC

**AIRPORT**

**ILO**

**MAIN STATION**

**SPEED**

connection to public transport



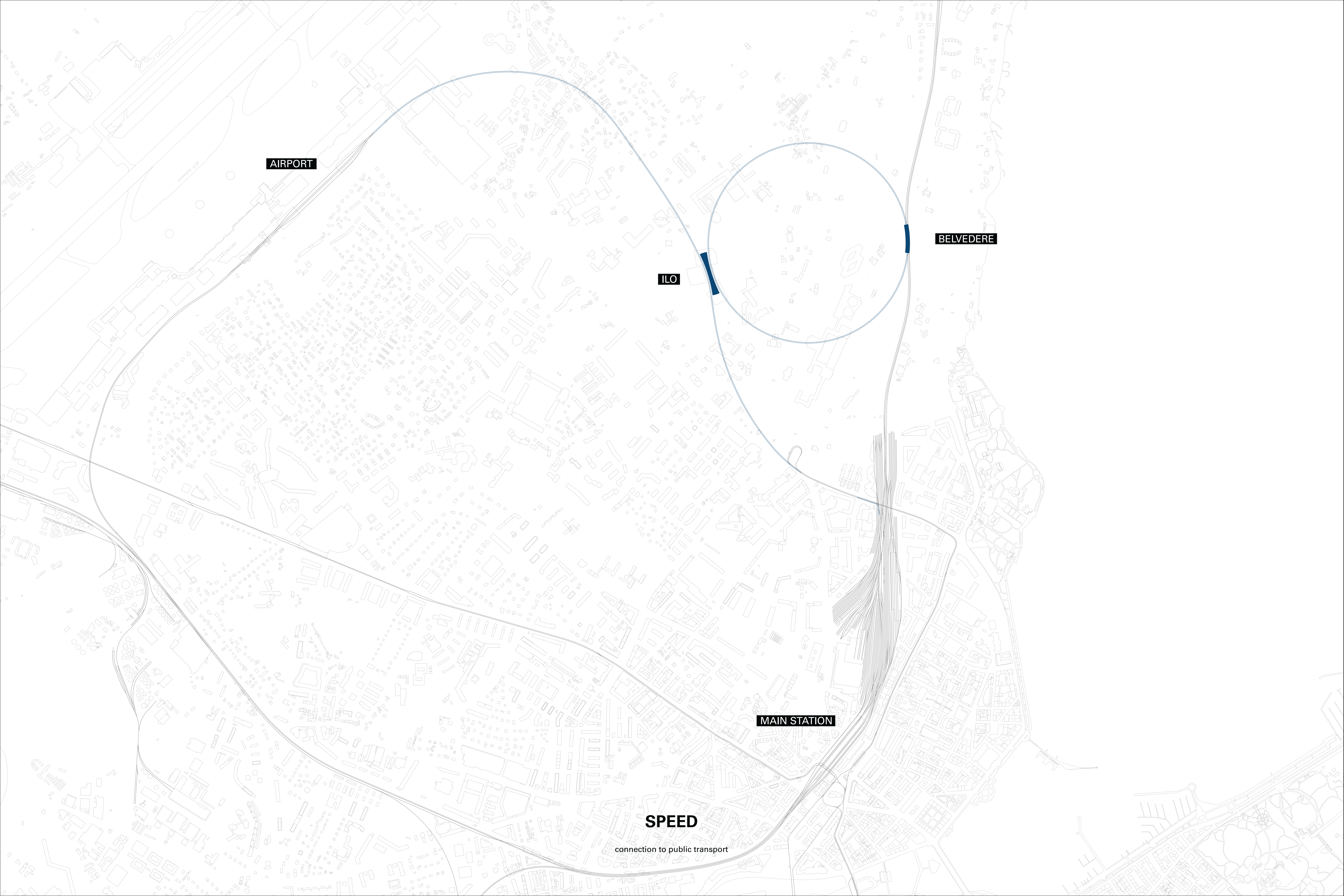

**AIRPORT**

**ILO**

**BELVEDERE**

**MAIN STATION**

**SPEED**

connection to public transport

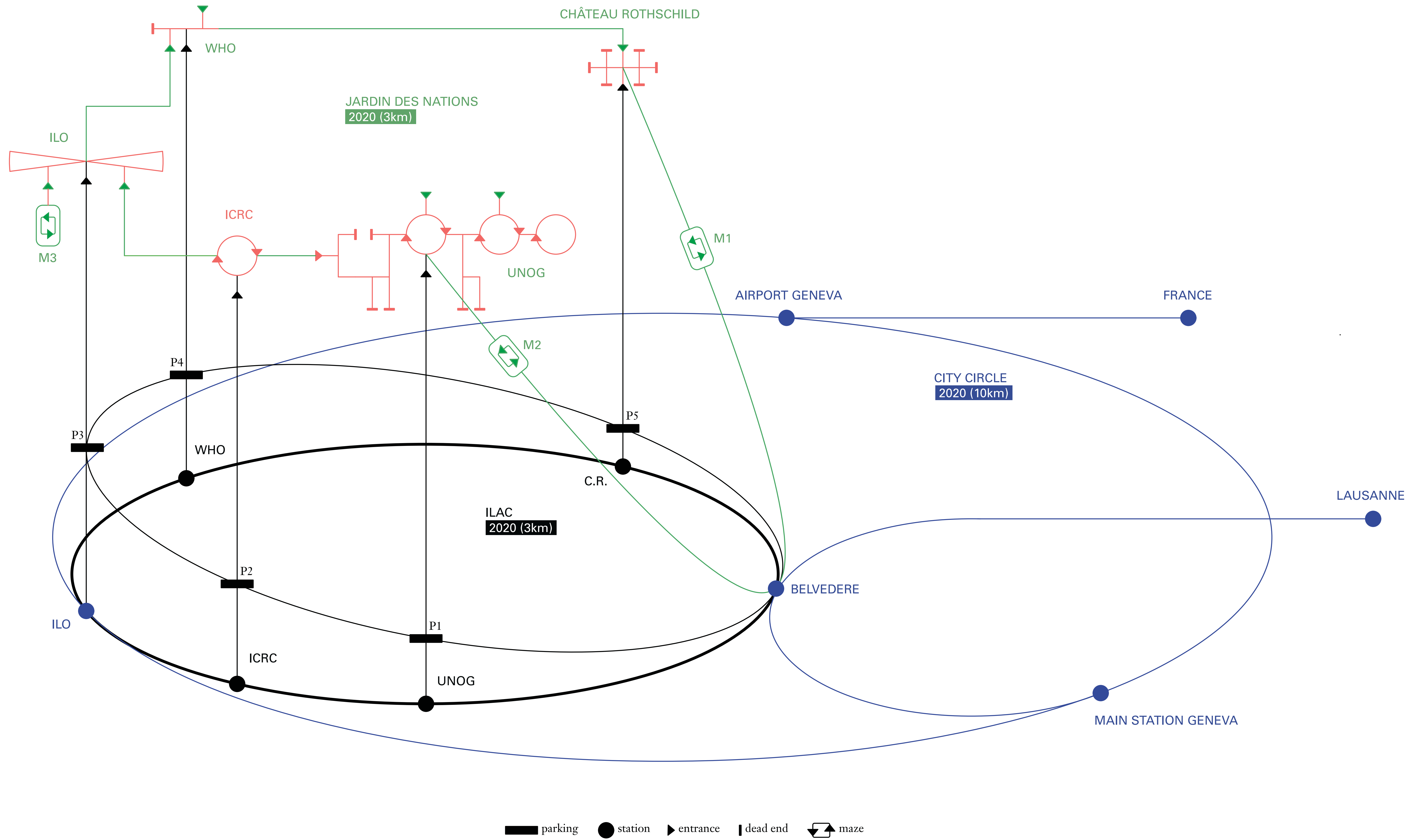

ILAC - INTERNATIONAL LOBBY ACCELERATOR COMPLEX // UNOG - UNITED NATIONS OF GENEVA // ICRC - INTERNATIONAL COMMITTEE OF THE RED CROSS  
 ILO - INTERNATIONAL LABOUR ORGANISATION // WHO - WORLD HEALTH ORGANISATION // V.R. - VILLA ROTHSCHILD

## INTERNATIONAL LOBBY ACCELERATOR COMPLEX

Complexe des accélérateurs du lobbying international



## THE EXPERIMENT



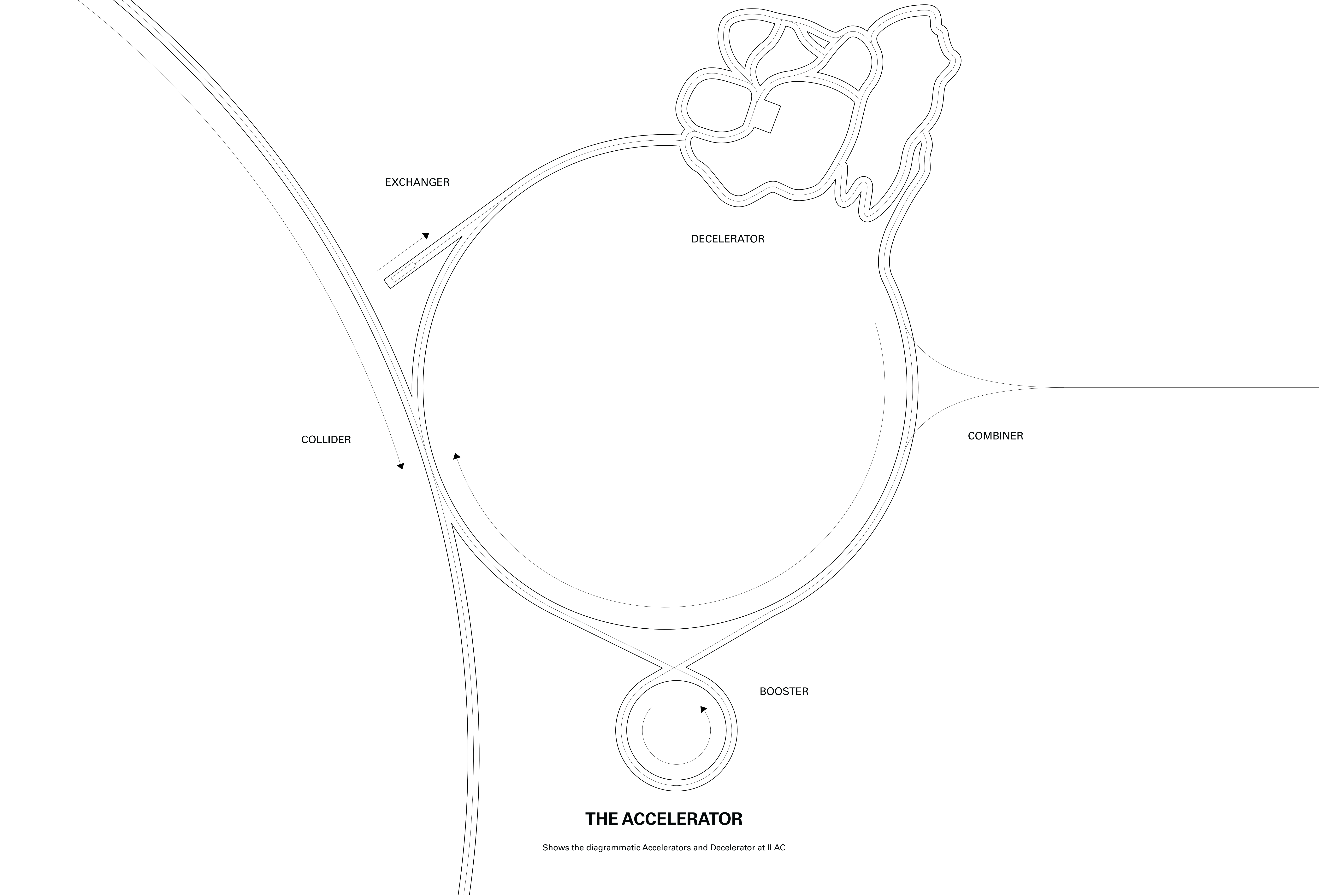

### THE ACCELERATOR

Shows the diagrammatic Accelerators and Decelerator at ILAC



- PUBLIC
- DIPLOMAT
- LOBBYIST

## ACCESSIBILITY & COLLISION

including people removes the exclusivity of lobbying



**SPEED I**

level 0 / PEDESTRIAN

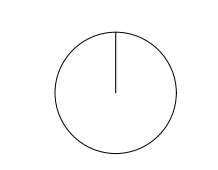



**SPEED II**

level -1 / CAR

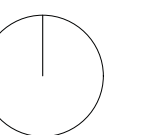



**SPEED III**

level -2 / METRO

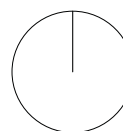



# COLLIDER

with the NODAL POINT at ILO

Being activated as a train station, the ILO becomes the new gateway to the Jardin des Nations for both the public and the employees of the International Organisations. As an intermediate station between the International Airport, the main station of Geneva and the ILAC it is in this particular point that the different social bubbles collide. The *Collider* removes the exclusivity of lobbying while making the population of Geneva part of the processes.

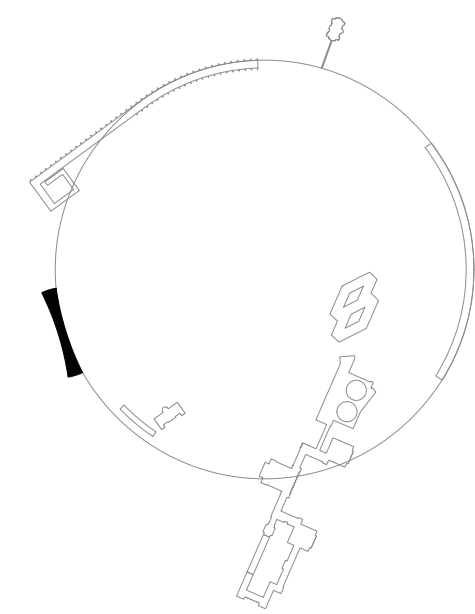
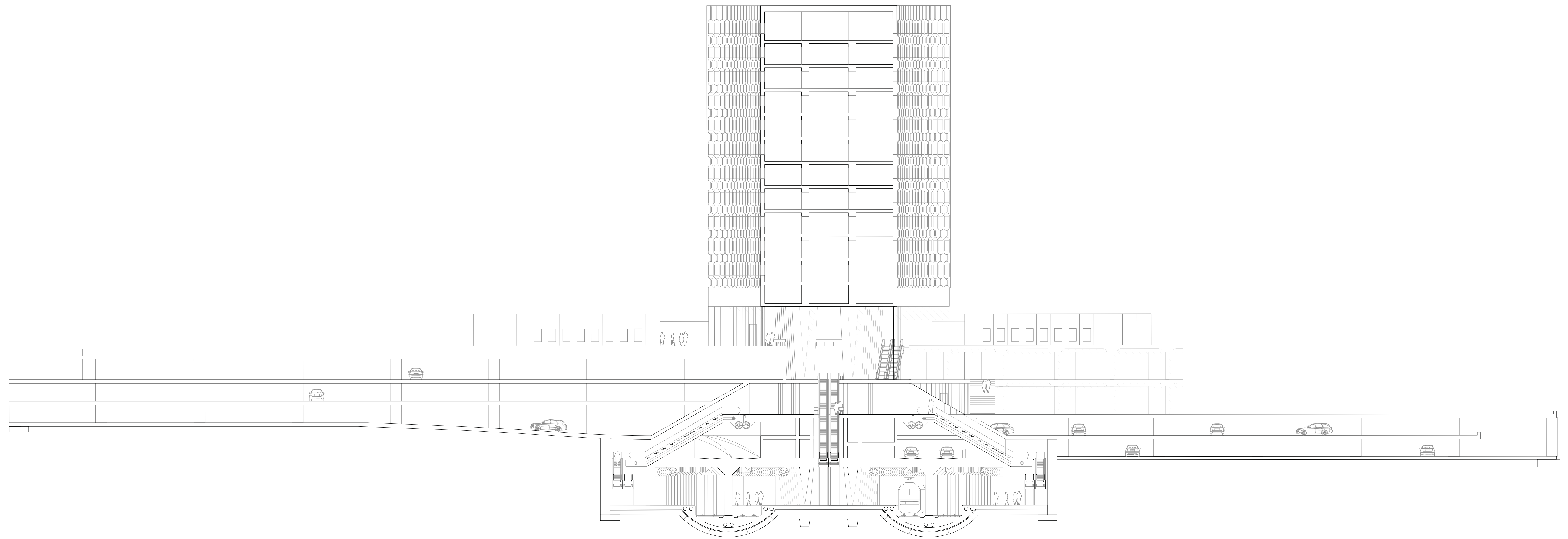

**COLLIDER**  
longitudinal section

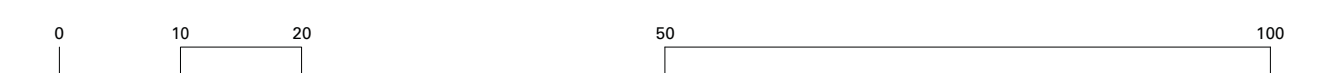



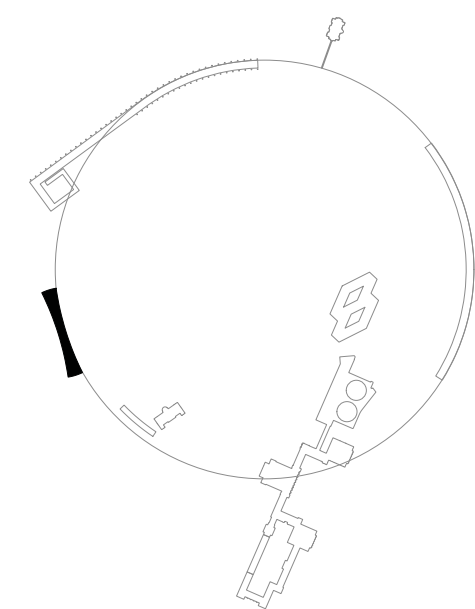
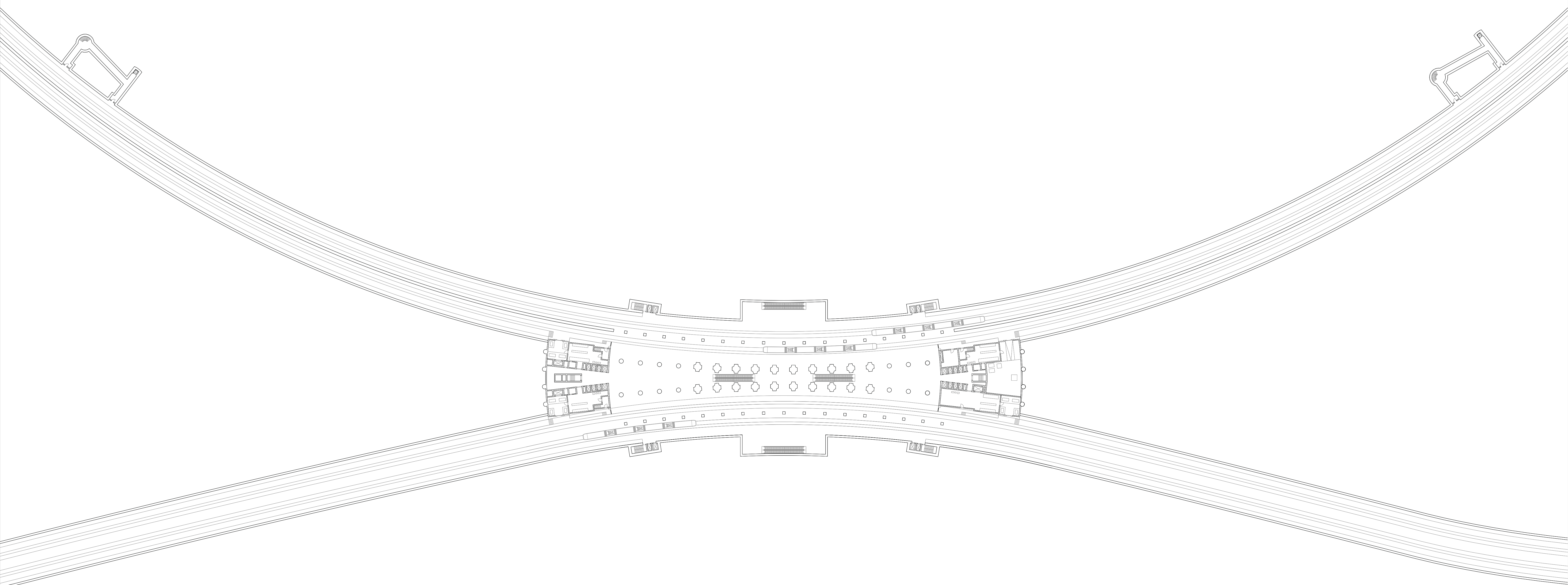

**COLLIDER**

IV-2

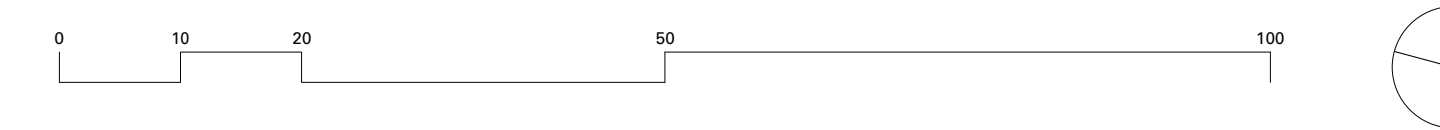

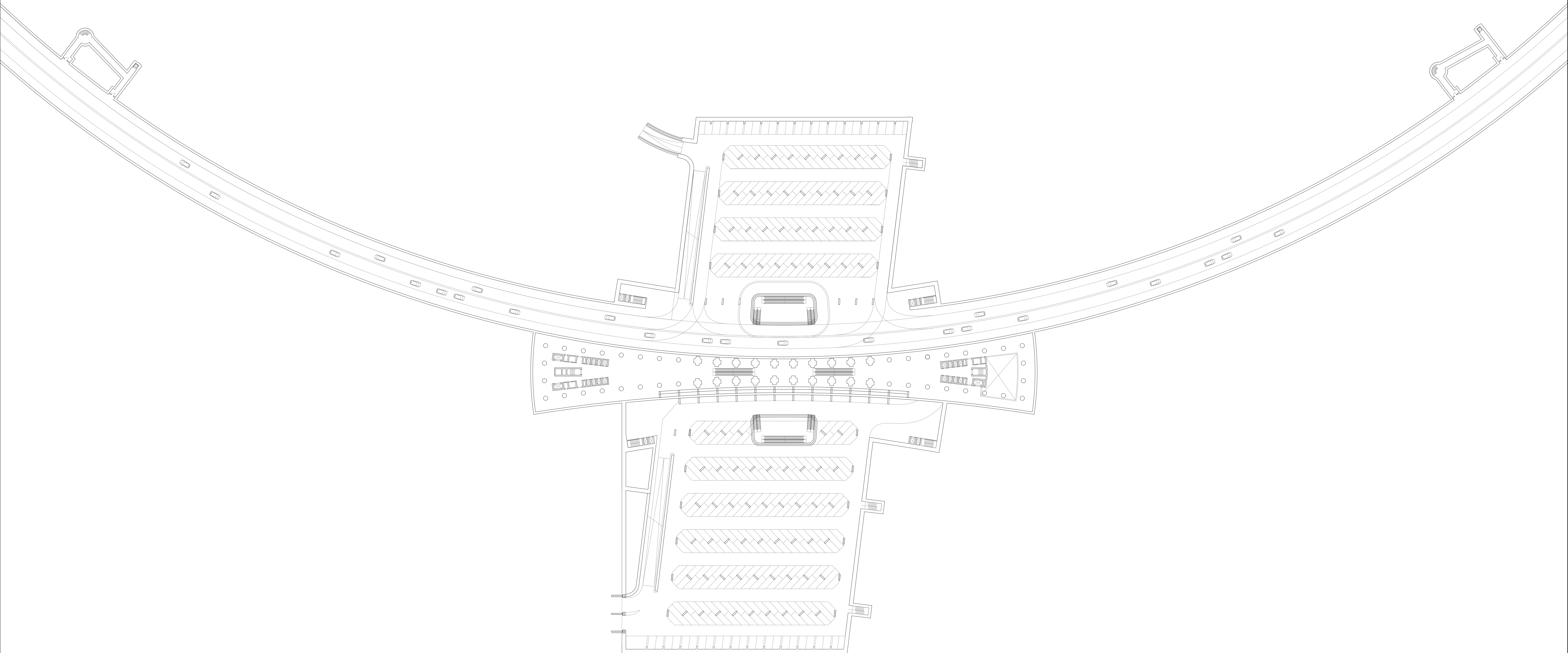

**COLLIDER**

IV-1

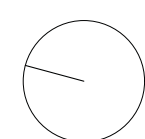
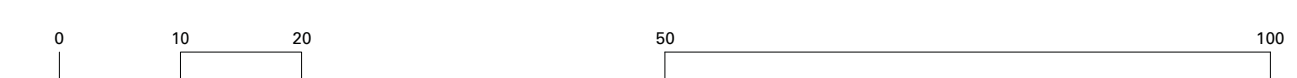
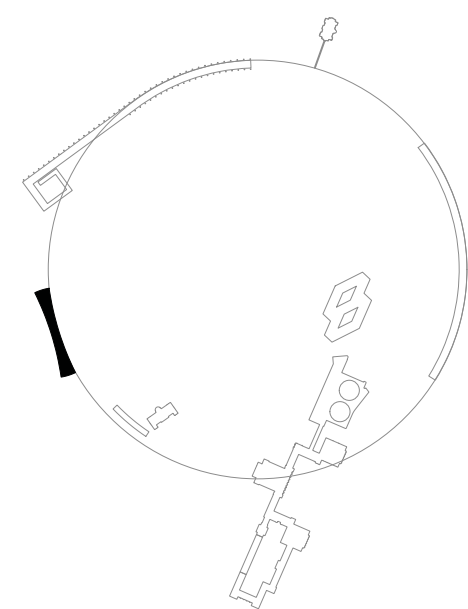

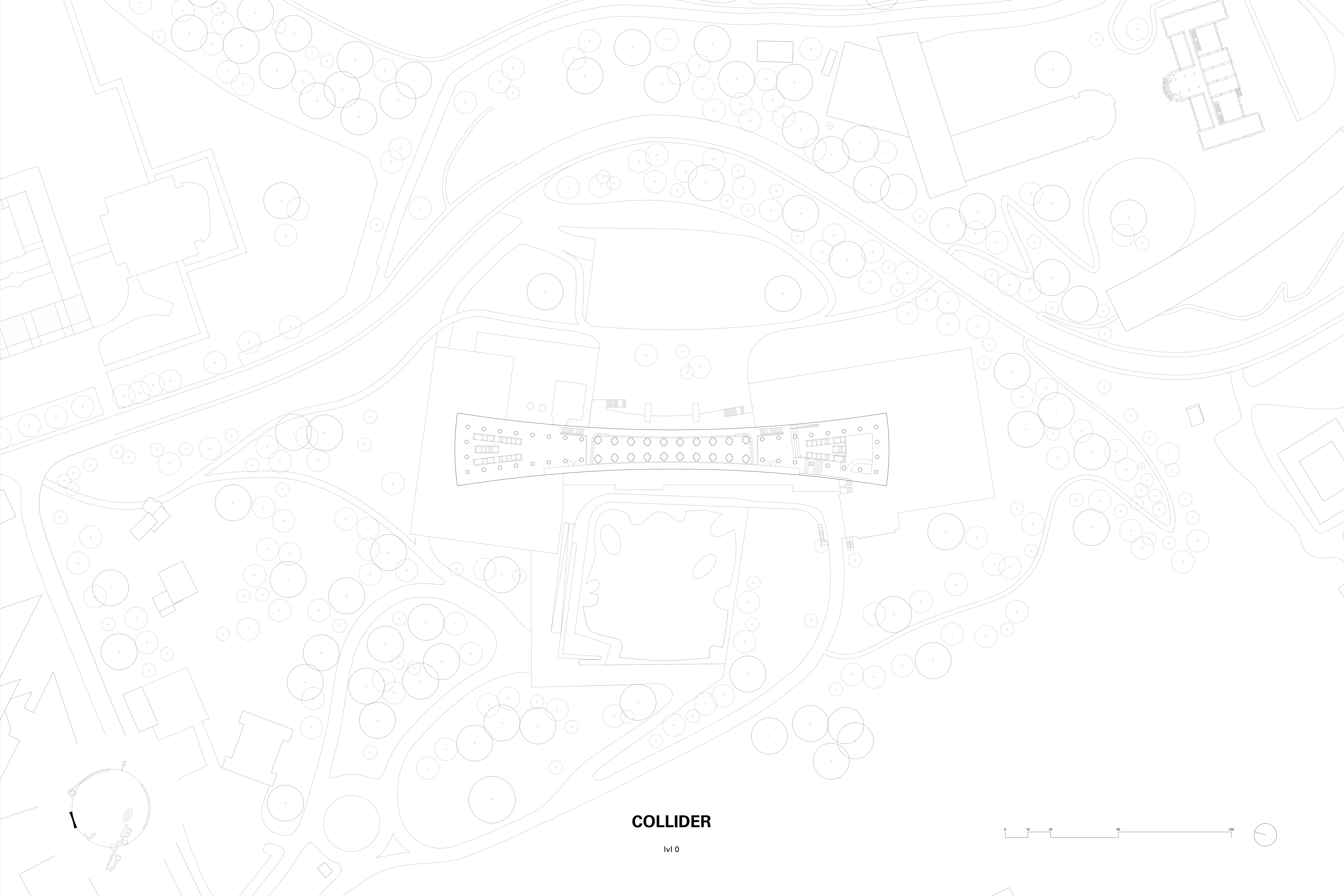

**COLLIDER**

lvl 0

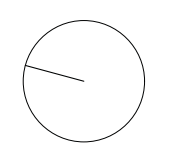
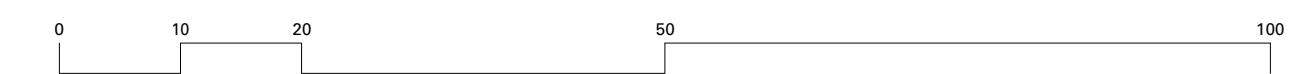
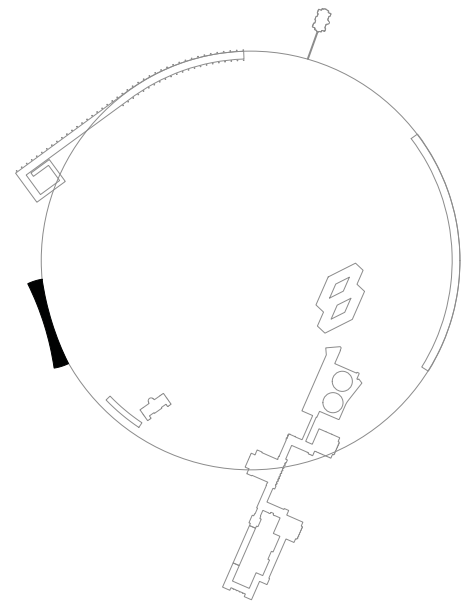

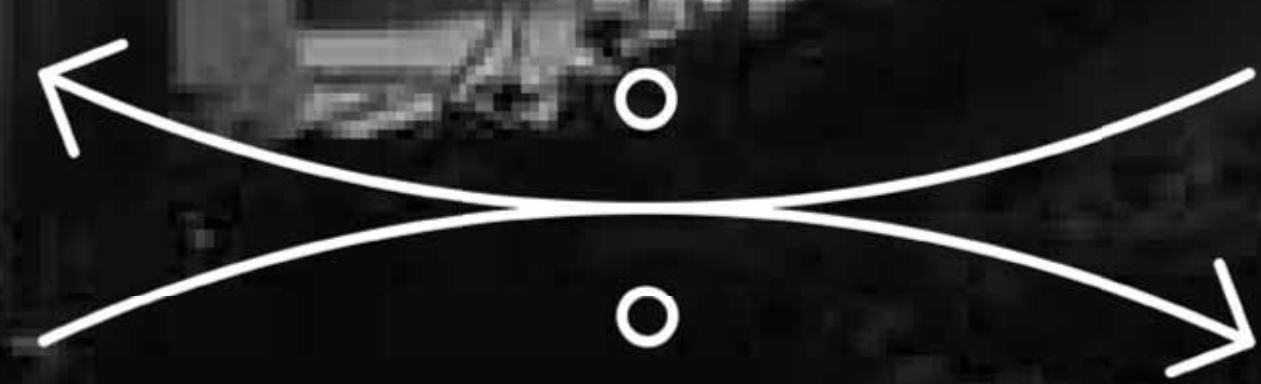

**EXCHANGER**

with the COLONNADES at the WHO

In the lobby between the colonnades of the WHO a lively exchange of information takes place. The colonnade continues and bends as soon as it meet the circle. By providing this new space, it generates the possibility of new locations for International Organisations in the North and South, with the *Exchanger* in between serving as a programmatic place of exchange in ILAC.

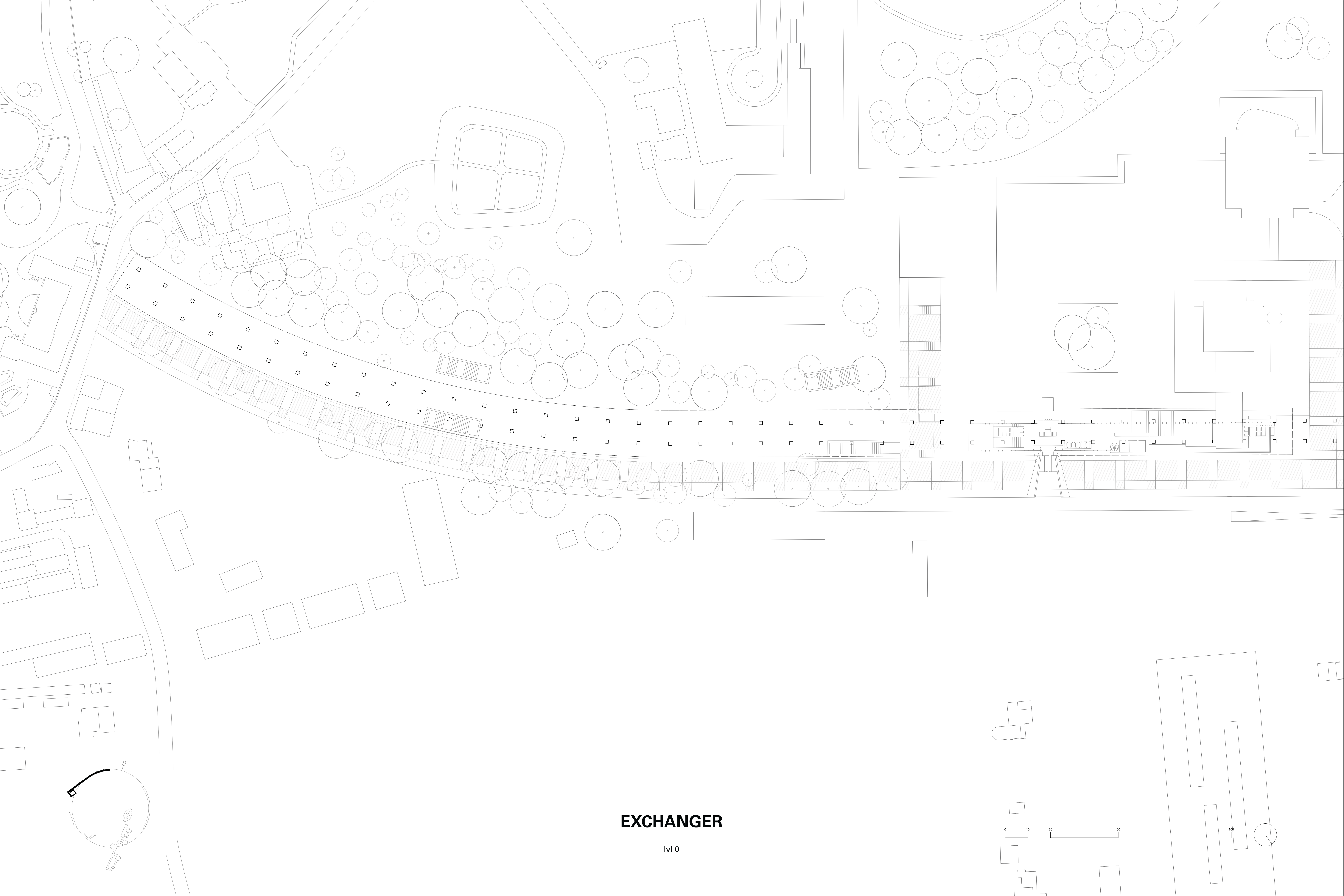

**EXCHANGER**

lvl 0



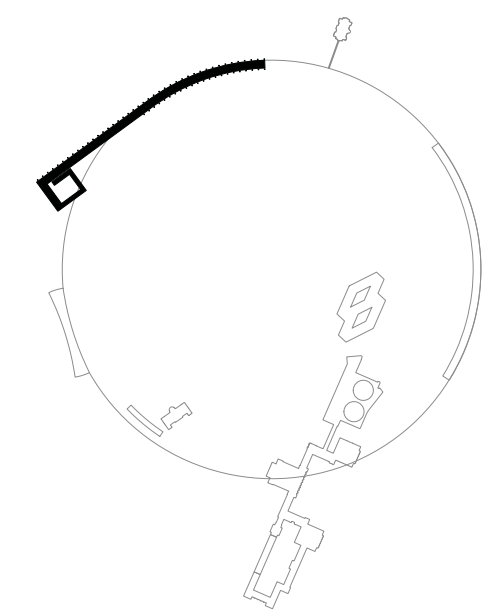
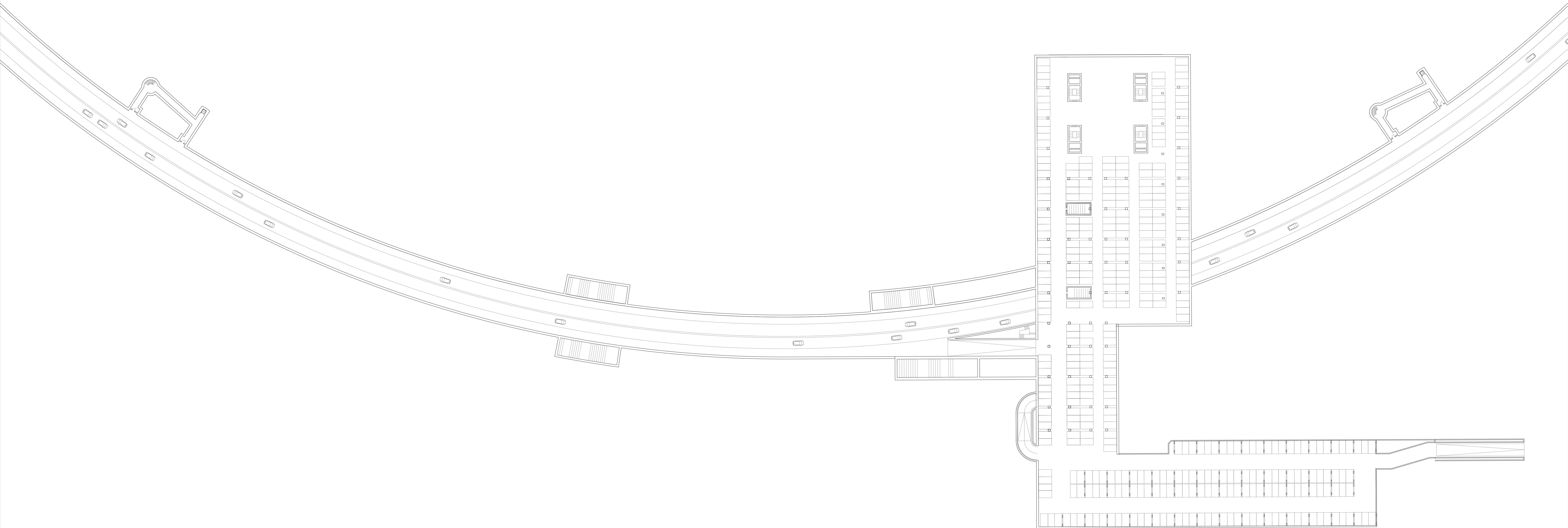

# EXCHANGER

IV-1

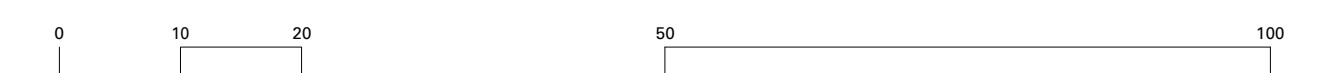

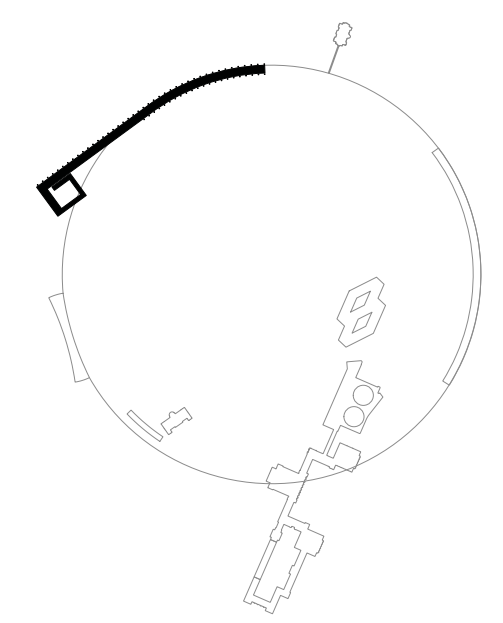
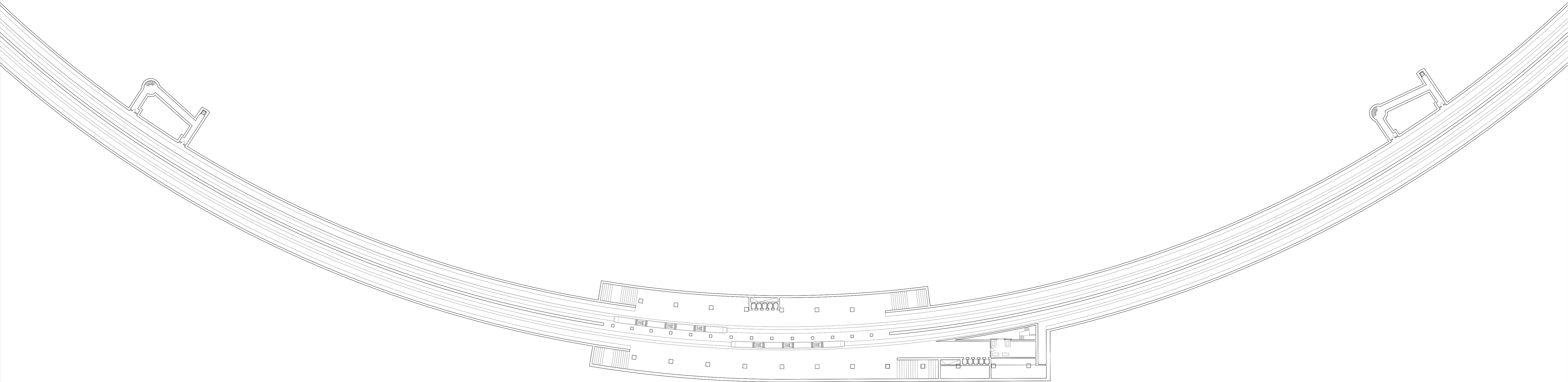

# EXCHANGER

IV-2

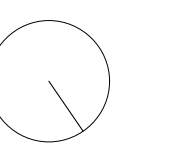
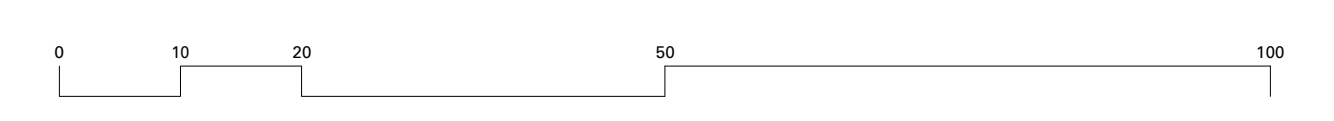





## DECELERATOR

with the GROTTO at VILLA ROTHSCHILD

In ILAC the park surrounding the Chateau-Rothschild serves as a *Decelerator*. The curved paths lead to informal places like a pool, a cemetery, an orangery or a pond. Inspired by the grotto typology an underground passage connects the castle with the transportation system while the aboveground maze offers the possibility for secret negotiations.



**DECELERATOR**

lvl 0

0 10 20 50 100

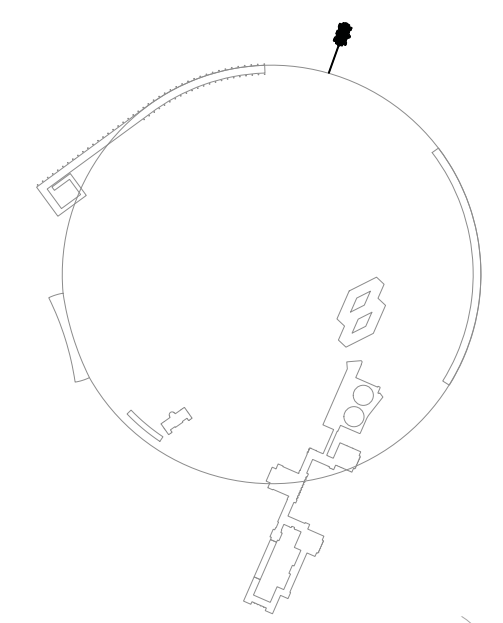
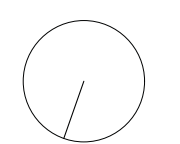

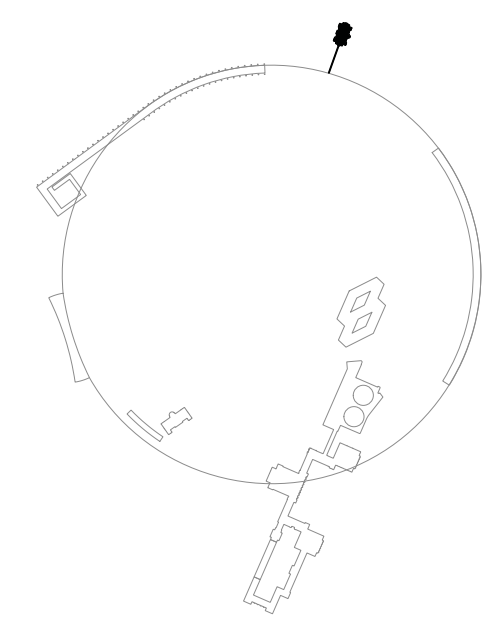
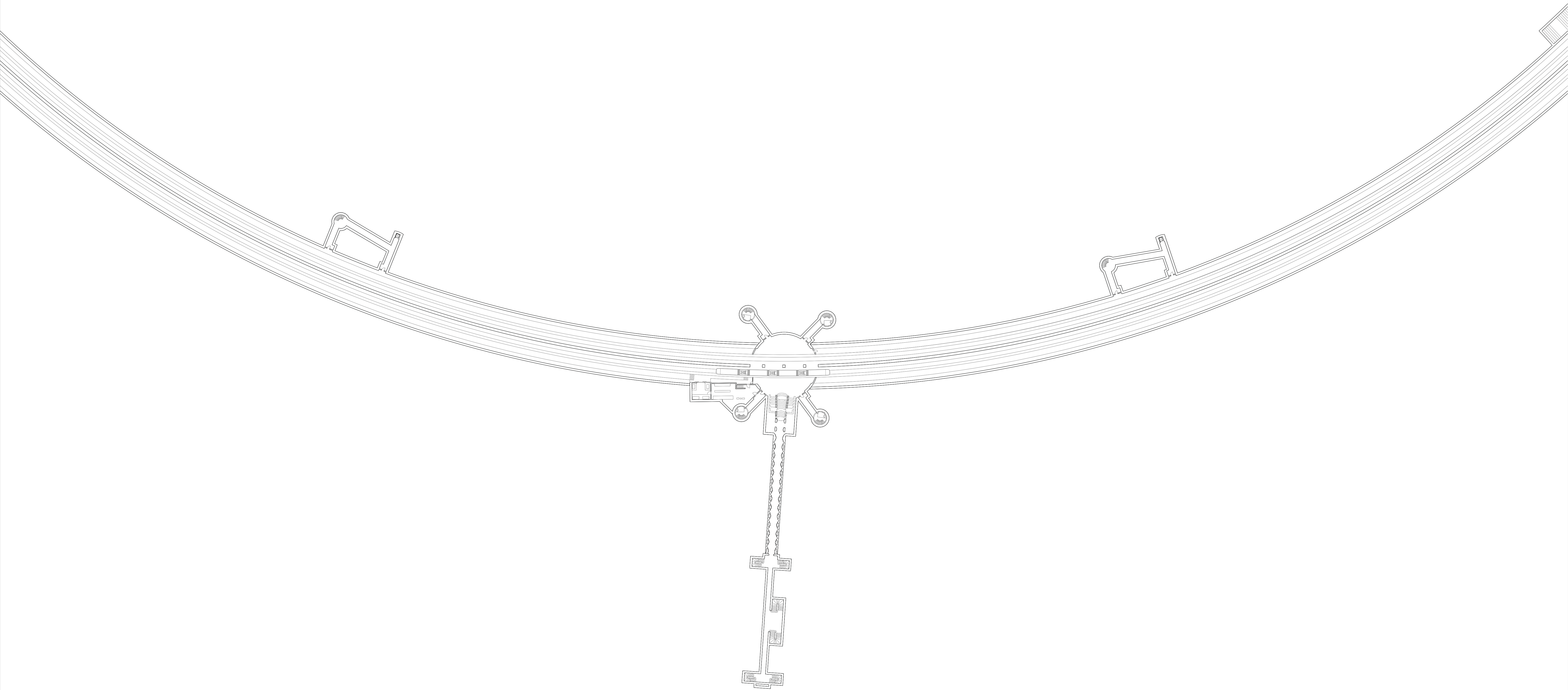

**DECELERATOR**

IV-2





**COMBINER**

with the BELVEDERE

As a visible part of ILAC, the *Combiner* connects the Botanical Garden as well as the long-distance traffic with the Jardin des Nations and docks at two ends to the circle. By overcoming the train boundary and offering a generous platform - the Belvedere - the *Combiner* serves to remove the exclusivity of lobbying and by making the population of Geneva included in the decision-making processes.



**COMBINER**

lvl 0

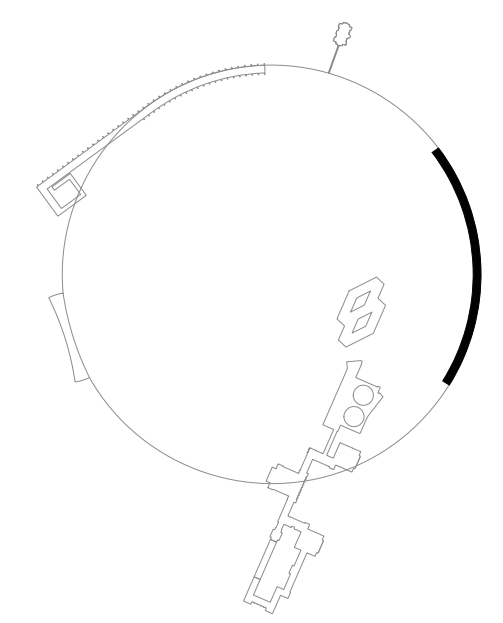

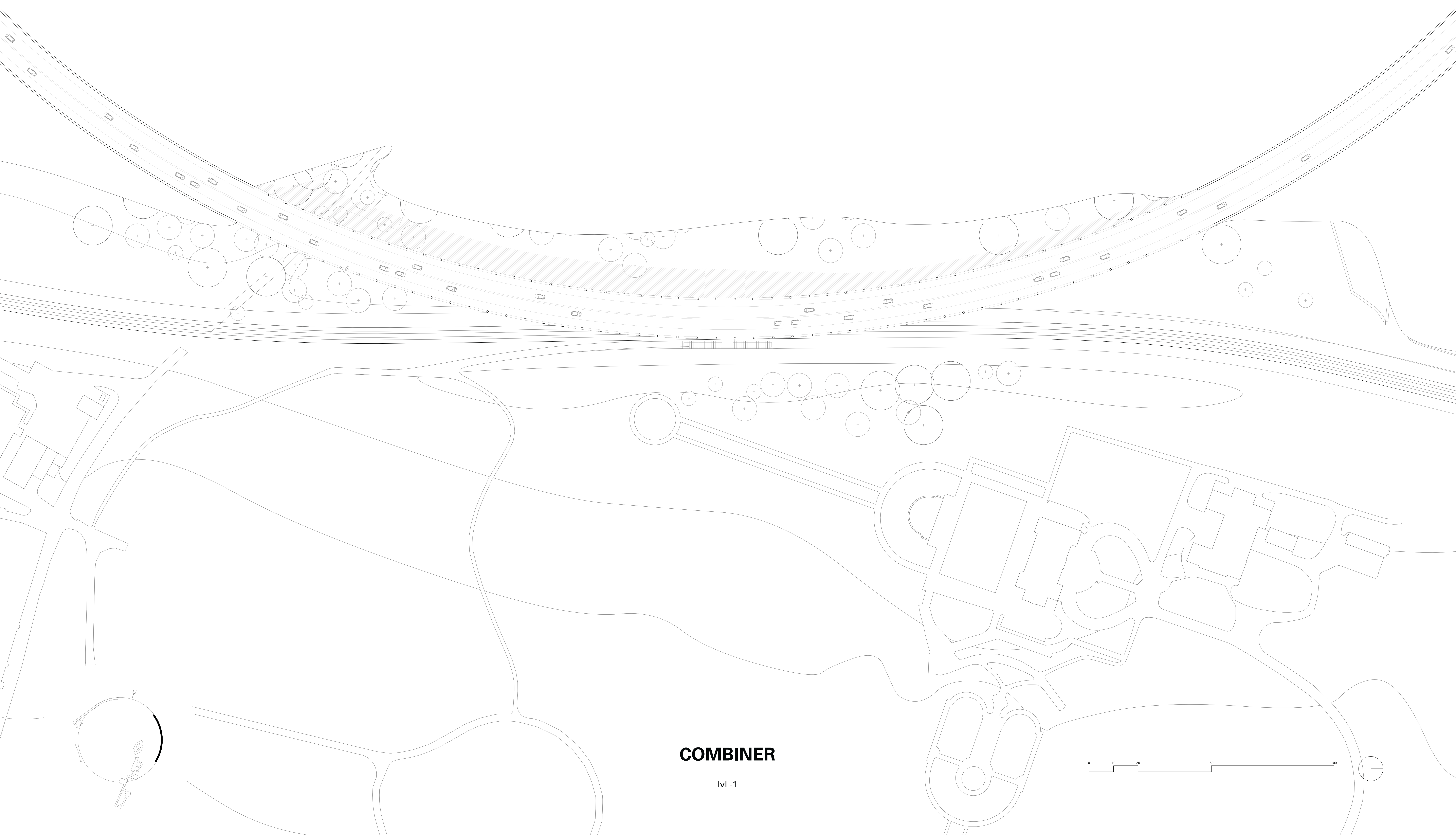

**COMBINER**

IV-1

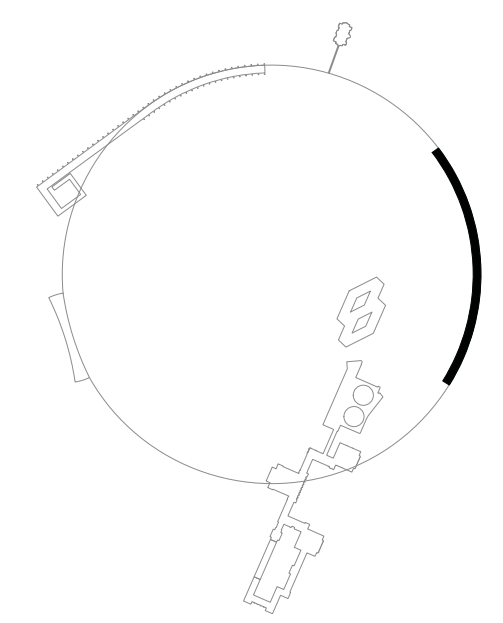





**COMBINER**

IV-2

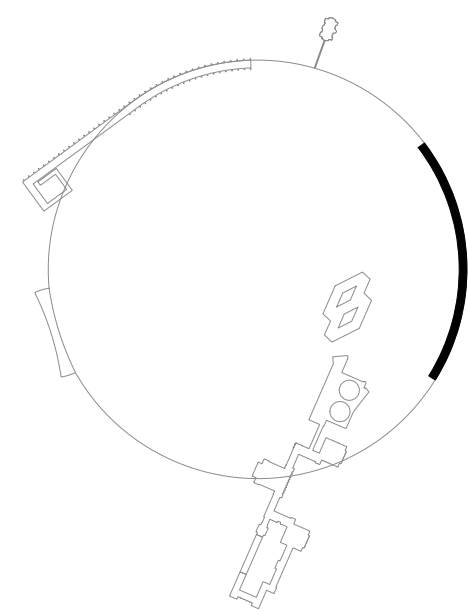



**BOOSTER**

with the LOOP at UNOG

By diverting the corridors leading away from the UN back to its centre, the *Booster* fosters a recurring debate on the same issues until a solution is found.

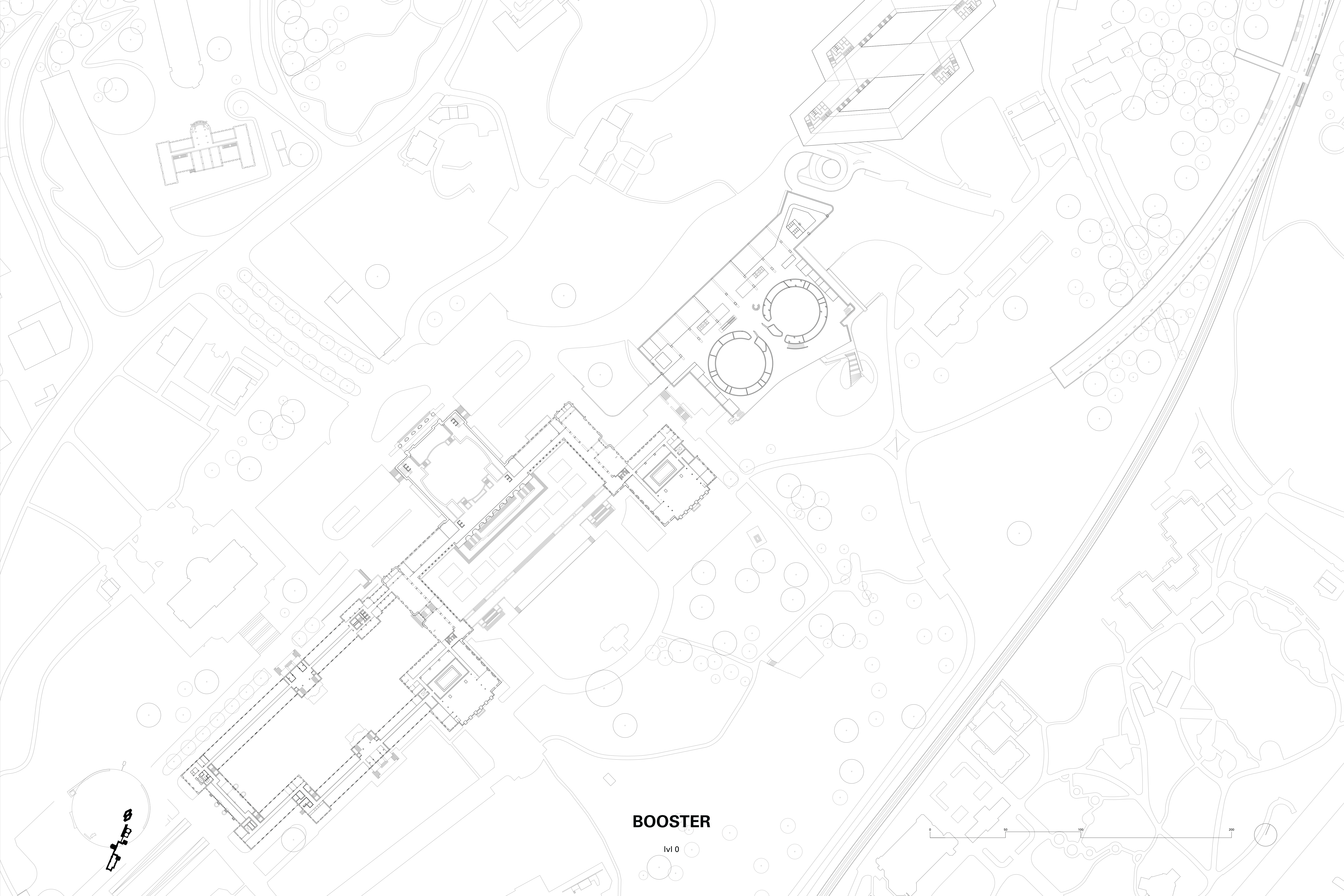

**BOOSTER**

lvl 0

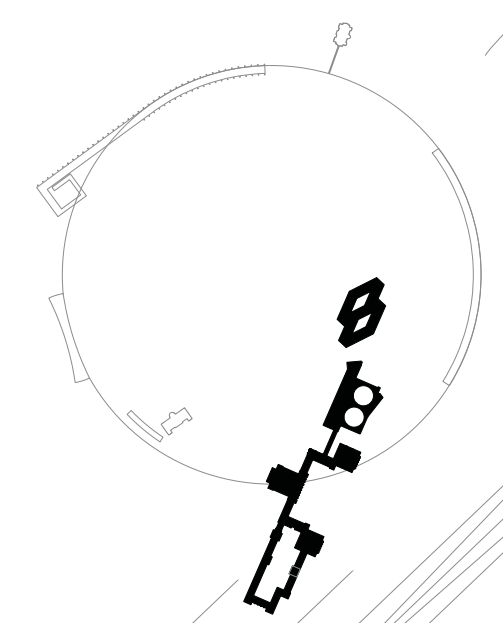
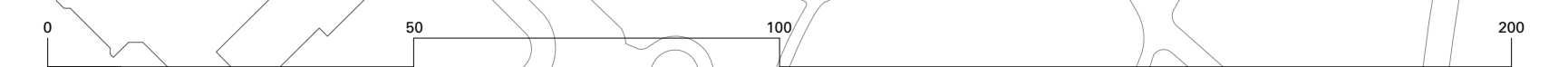

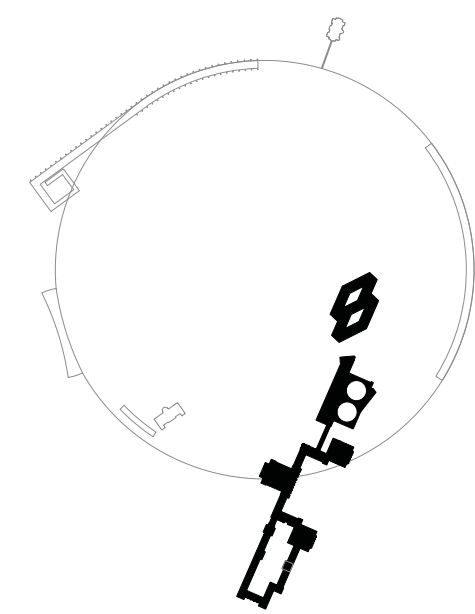
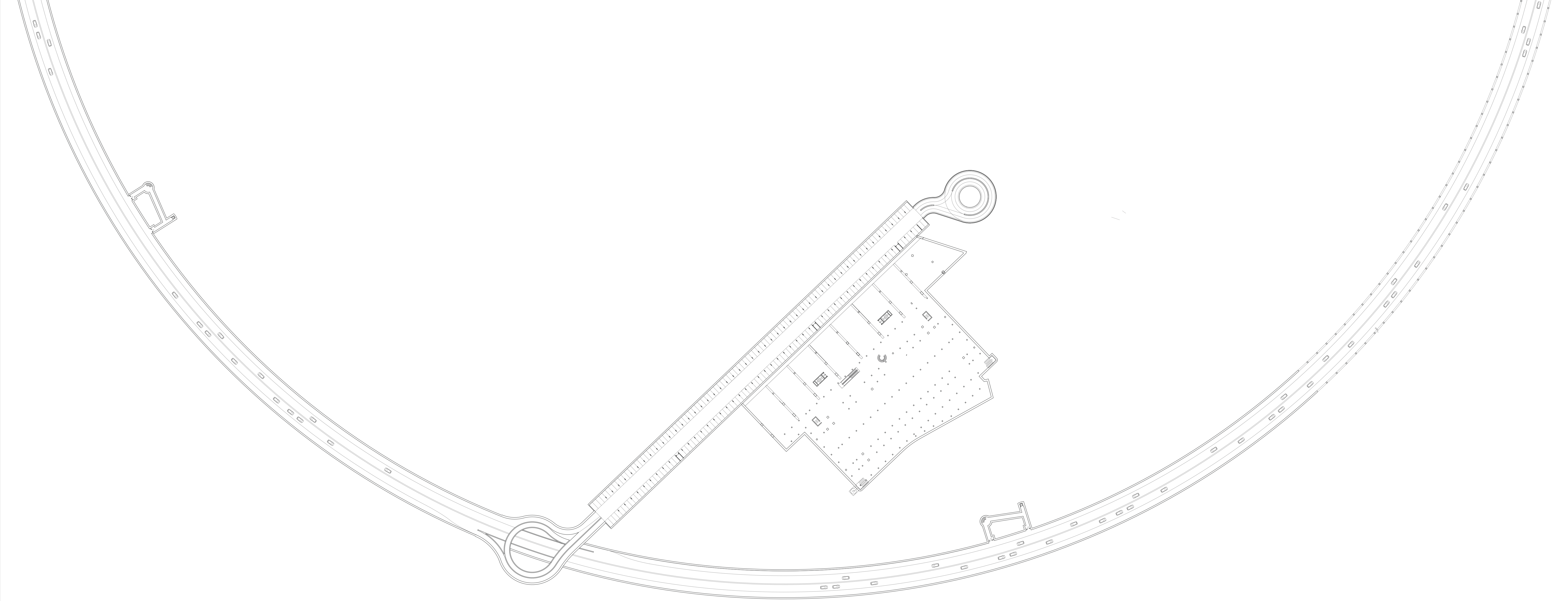

# BOOSTER

IV-1

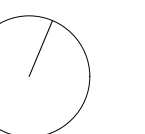
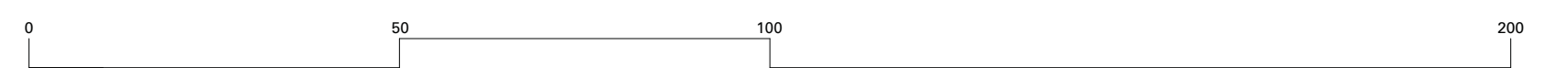

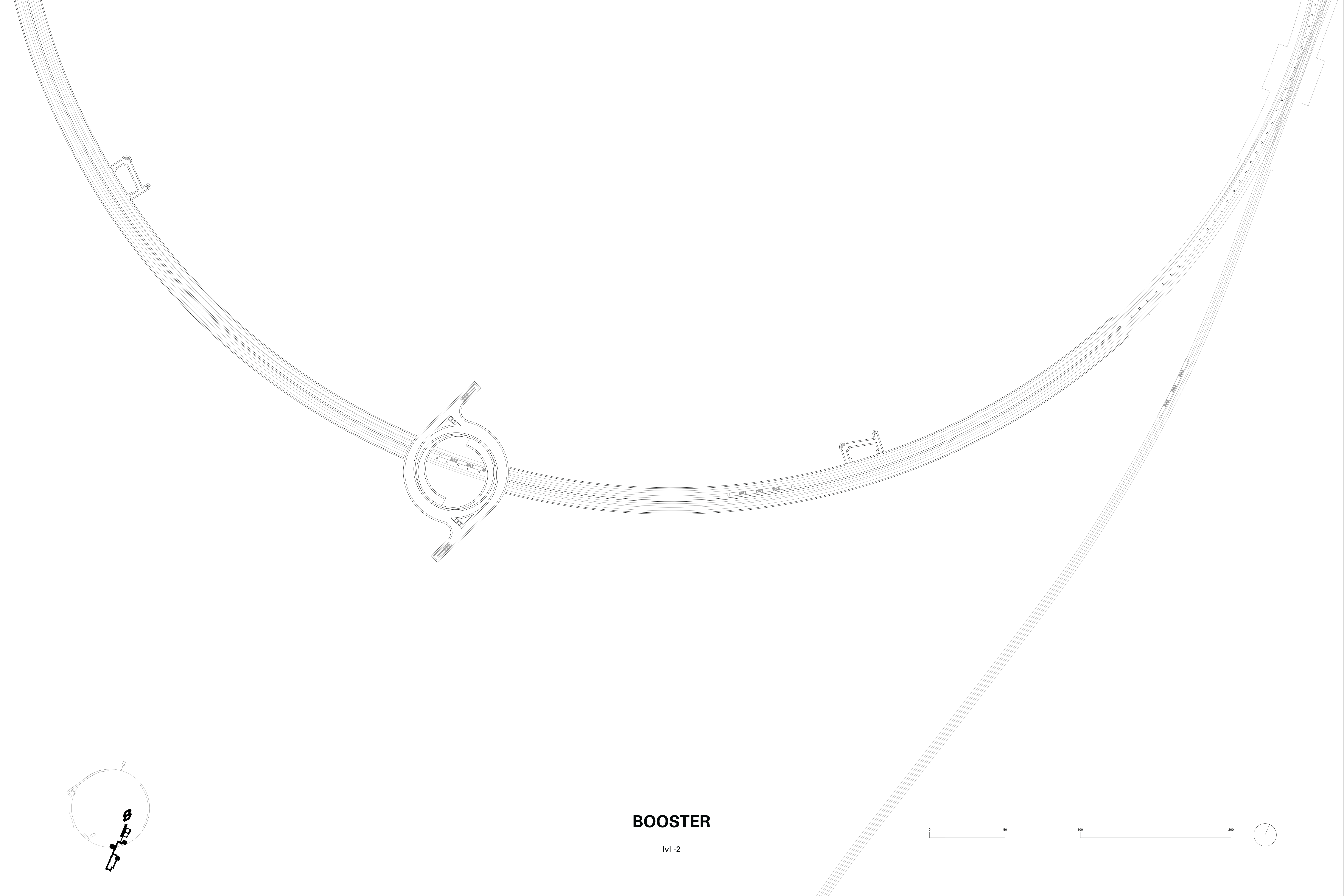

**BOOSTER**

IV-2

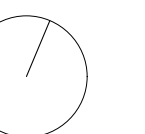
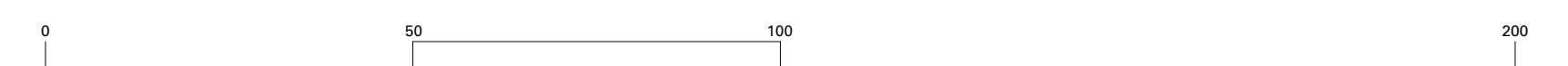
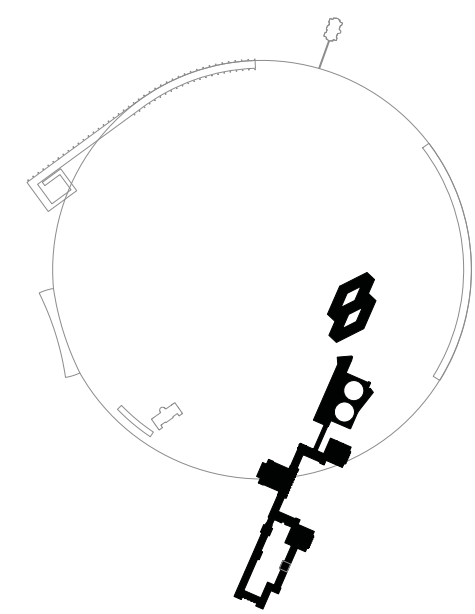



COLLIDER

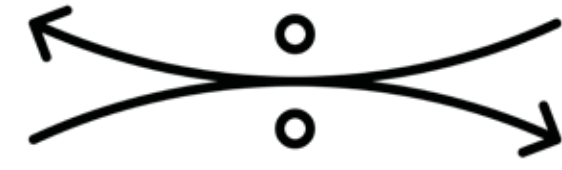

EXCHANGER

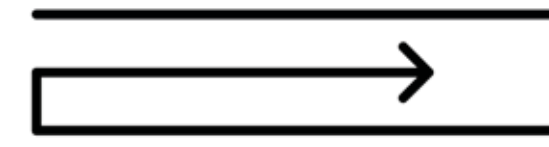

DECELERATOR



COMBINER



BOOSTER

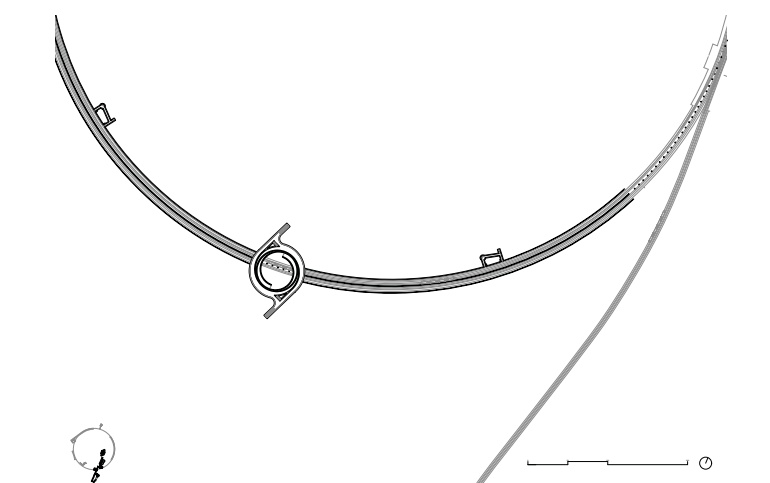
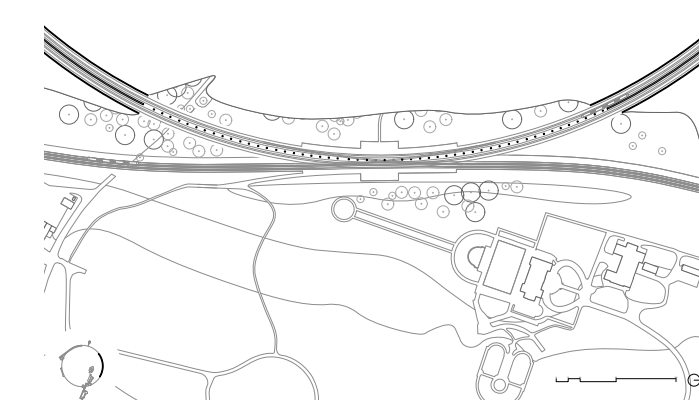
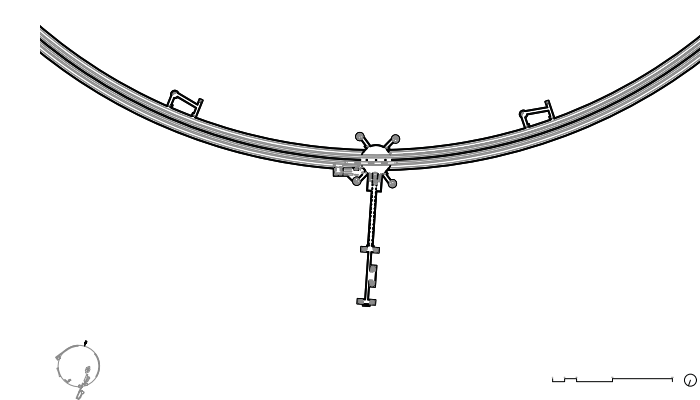
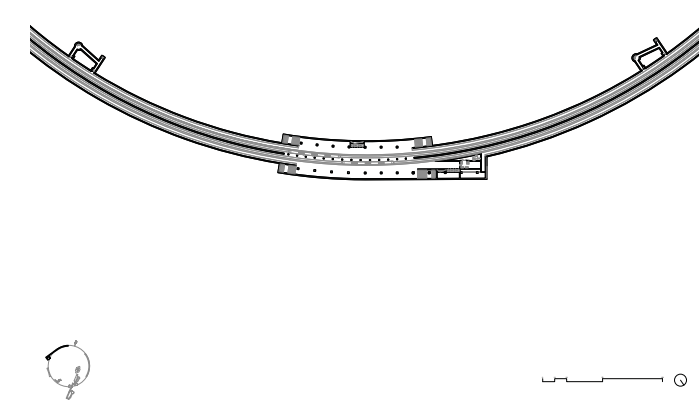
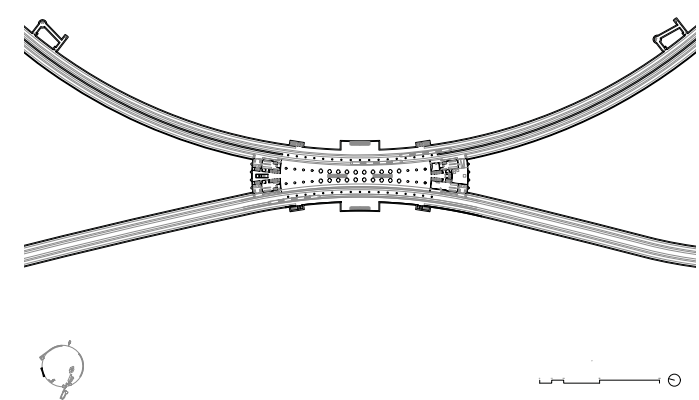
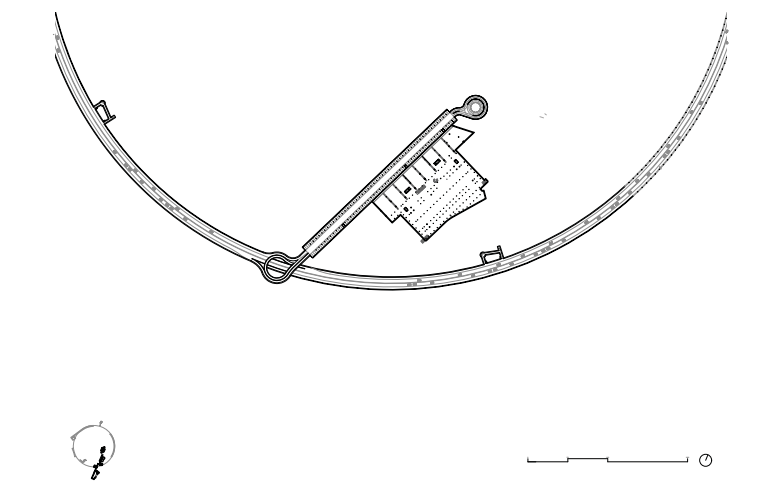
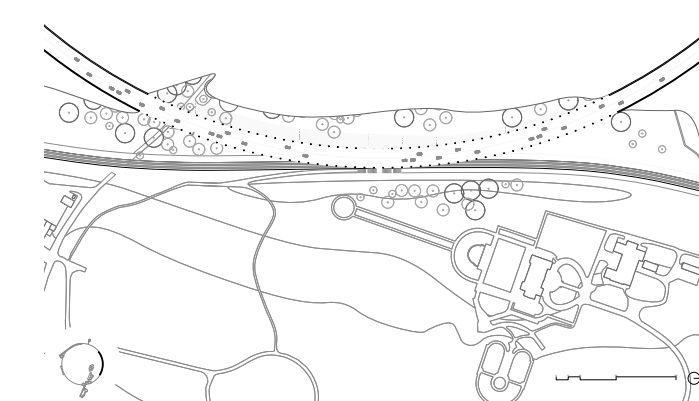
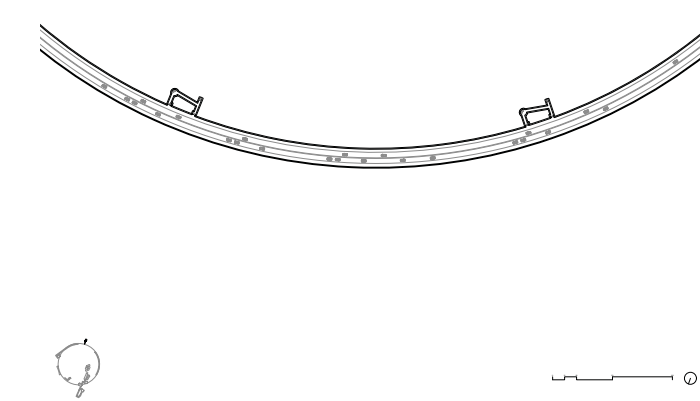
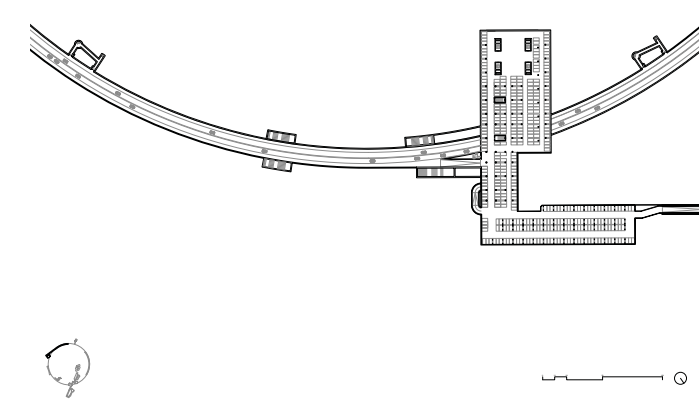
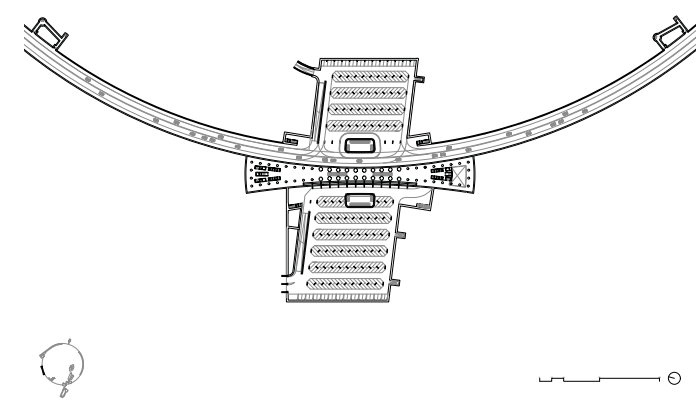
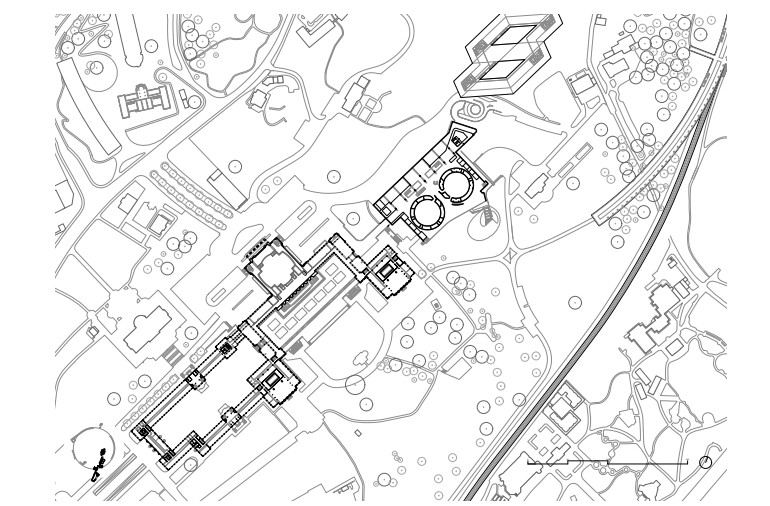
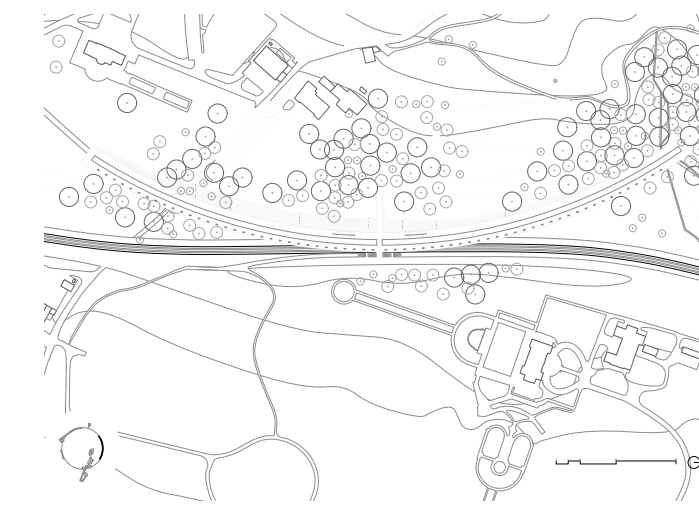
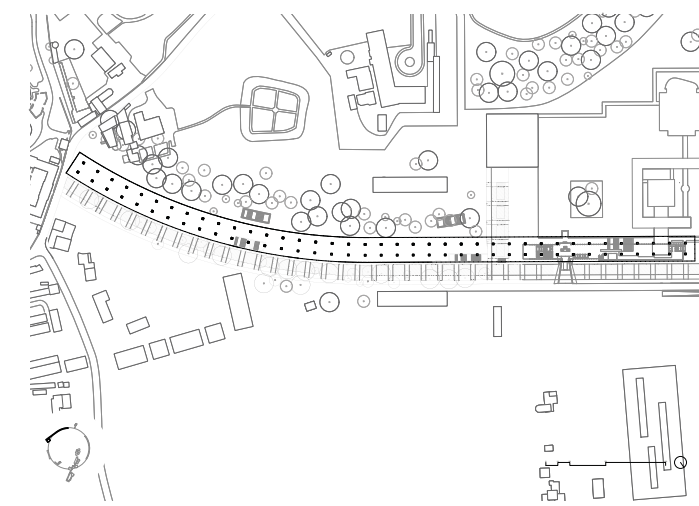
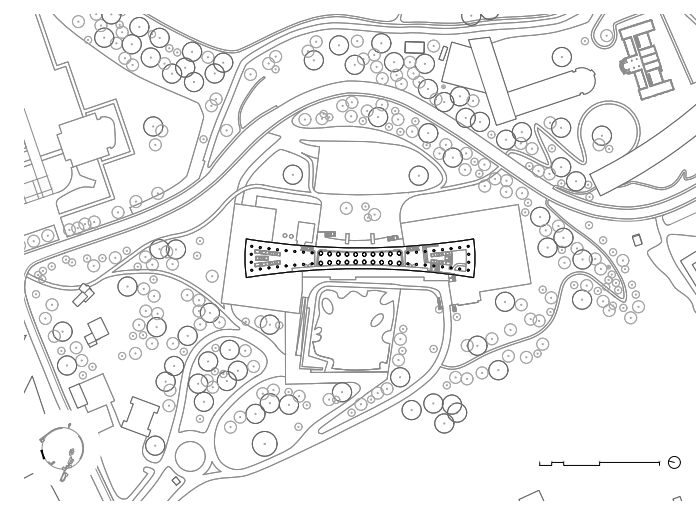

ILO

WHO

ROTHSCHILD

BELVEDERE

UNOG

# MAPPING THE ILAC

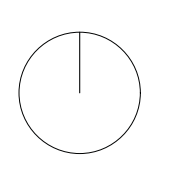



**VIDEO**

<https://vimeo.com/481209738/aebe315473>